

The Most **Reliable** Storage For Industries

PV910-M230

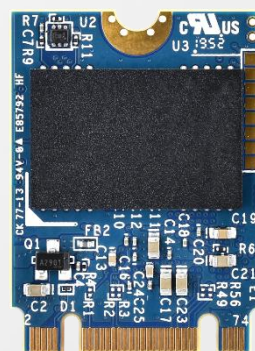

Specifications

Model	PV910-M230
Interface	PCIe Gen3 x2
Connector	M.2 B & M key
Form Factor	M.2 2230
NAND Flash Type	3D TLC
Capacity	60GB~240GB
External DRAM	No
Sustained Read Performance (MB/sec)	Up to 890
Sustained Write Performance (MB/sec)	Up to 745
ECC Engine	Low-Density Parity-Check (LDPC) Code
IOPS (4K Random Write)	125K
Standard Operating Temperature (°C)	0 ~ + 70
Extended Operating Temperature (°C)	-40 ~ + 85
Storage Temperature (°C)	-40 ~ + 100
Thermal Sensor	Yes
Shock	Operation: 50G/11ms (compliant with MIL-STD-202G) Non-operation: 1500G/0.5ms (compliant with MIL-STD-883K)
Vibration	Operation: 7.69 Grms, 20~2000 Hz/random (compliant with MIL-STD-810G) Non-operation: 4.02 Grms, 15 ~ 2000 Hz/sine (compliant with MIL-STD-810G)
Operating Voltage	3.3V ±5%
Power Consumption	Active mode: 445 mA / Idle mode: 150 mA
Dimension (L x W x H)	30.00 x 22.00 x 3.88 (mm)
MTBF (hours)	>3,000,000

Mechanical Specification

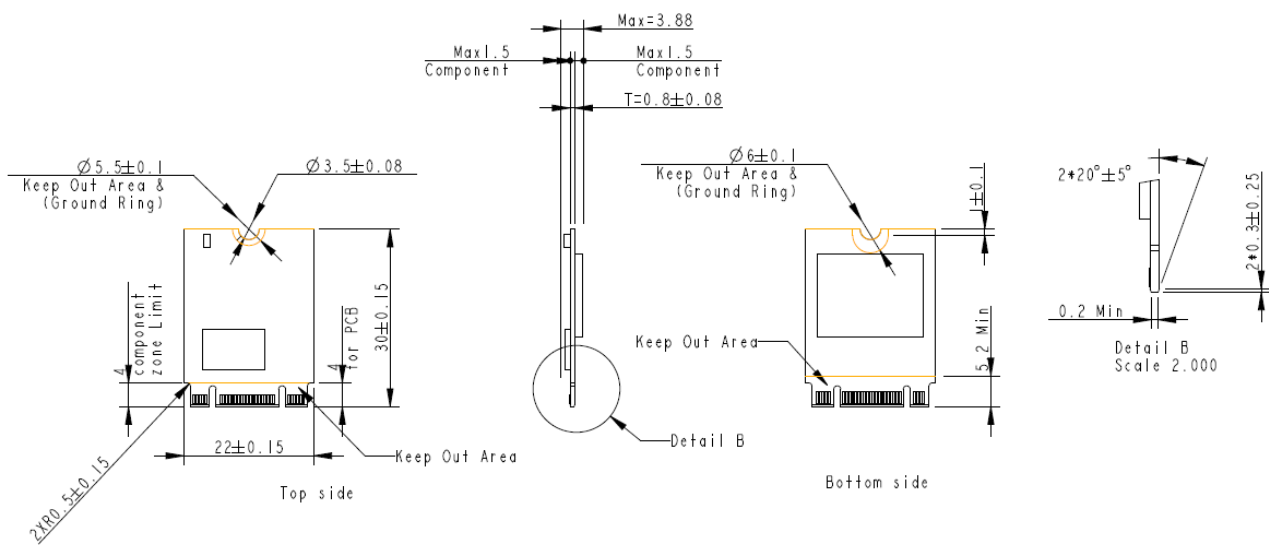

Unit: mm

For more information,
contact your Apacer representative

Global Presence

Taiwan (Headquarters)
Apacer Technology Inc.
Tel: +886-2-2267-8000
Fax: +886-2-2267-2261

Europe
Apacer Technology B.V.
Tel: +31-40-267-0000
Fax: +31-40-290-0686

U.S.A.
Apacer Memory America, Inc.
Tel: +1-408-518-8699
Fax: 1-510-249-9551

China
Apacer Electronic(Shanghai)
Co., Ltd.
Tel: +86-21-6228-9939

Japan
Apacer Technology Corp.
Tel: +81-3-5419-2668
Fax: +81-3-5419-0018

India
Apacer Technologies Pvt. Ltd.
Tel: +91-80-41529061~3
Fax: +91-80-41700215