

Apacer

The Most **Reliable**
Storage For Industries

PV920-M280



PV920-M280

Overview

Apacer PV920-M280 is the fastest SSD designed to M.2 2280 mechanical dimensions, providing full compliance with PCIe Gen3 x4 interface and NVMe 1.3 specifications.

Built with a powerful PCIe controller, PV920-M280 delivers outstanding performance in data transfer, reaching up to 388,000/276,000 and 3,535/2,745 MB/s in IOPS and sequential read/write. The extreme thin and light form factor makes PV920-M280 the ideal choice for mobile computing systems, which appears to be the trend in the near future.

Regarding reliability, PV920-M280 supports on-the-module ECC as well as an efficient Wear Leveling scheme. Furthermore, End-to-End Data Protection guarantees data integrity at multiple points in the path to enable reliable delivery of data transfers. Security-wise, Advanced Encryption Standard (AES) ensures data security and provides users with a peace of mind knowing their data is safeguarded, while Signed Firmware allows firmware to be updated in a secure way with a digital signature. PV920-M280 is compliant with the PCIe Gen3 x4 interface standard so that it can operate in power management modes, which greatly saves on power consumption.



Feature

- Adopts advanced LDPC ECC engine with 3D NAND flash memory to improve reliability
- Global Wear Leveling
- Flash bad-block management
- Flash Translation Layer: Page Mapping
- S.M.A.R.T.
- Power Failure Management
- TRIM
- Hyper Cache Technology
- NVMe Secure Erase
- Signed Firmware

Specifications

Model	PV920-M280
Interface	PCIe Gen3 x4
Connector	M.2 M Key
Form Factor	M.2 2280 single side, M Key: 160GB M.2 2280 double side, M Key: 320GB, 640GB
NAND Flash Type	3D TLC
Capacity	Single side: 240GB~480GB Double side: 960GB~1920GB
External DRAM	No
Sustained Read Performance (MB/sec)	Up to 3535
Sustained Write Performance (MB/sec)	Up to 2745
ECC Engine	Low-Density Parity-Check (LDPC) Code
IOPS (4K Random Write)	276K
Standard Operating Temperature (°C)	0 ~ + 70
Extended Operating Temperature (°C)	-40 ~ + 85
Storage Temperature (°C)	-40 ~ + 100
H/W Write Protect	Yes
Thermal Sensor	Yes
Shock	Operation: Acceleration, 50(G)/11(ms)/half sine (compliant with MIL-STD-202G) Non-operation: Acceleration, 1,500(G)/0.5(ms)/half sine (compliant with MIL-STD-883K)
Vibration	Operation: 7.69 Grms, 20~2000 Hz/random (compliant with MIL-STD-810G) Non-operation: 4.02 Grms, 15~2000 Hz/random (compliant with MIL-STD-810G)
Operating Voltage	3.3V±5%
Power Consumption	Active mode: 1100 mA / Idle mode: 260 mA
Dimension (L x W x H)	Single side: 22.00 x 80.00 x 2.58 (max) (mm) Double side: 22.00 x 80.00 x 4.08 (max) (mm)
MTBF (hours)	>3,000,000

Mechanical Specification

Single side

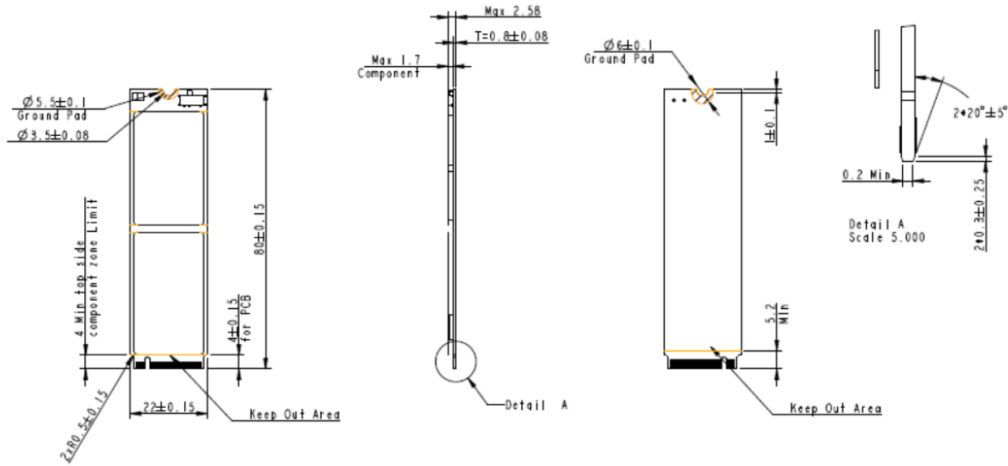

Double side

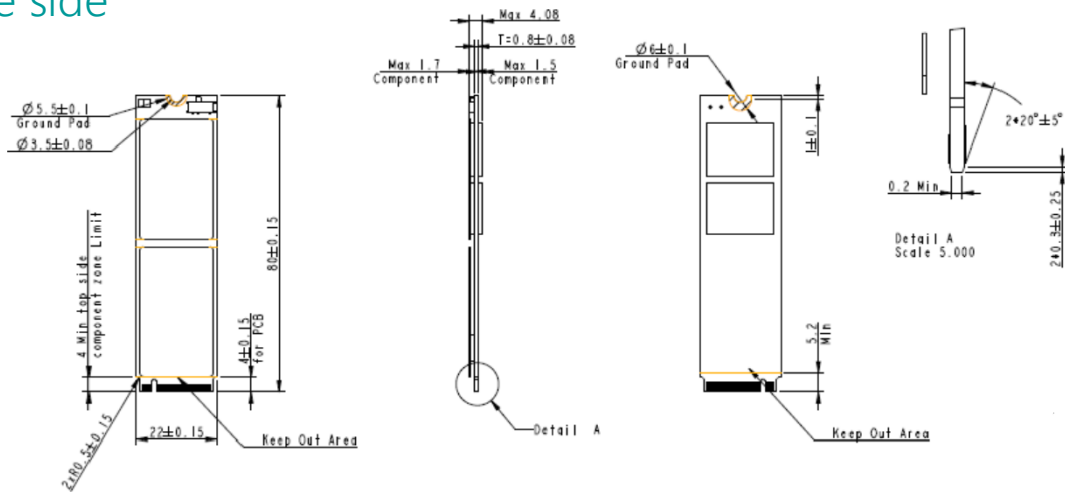

Unit: mm

For more information,
contact your Apacer representative

Global Presence

Taiwan (Headquarters)
Apacer Technology Inc.
Tel: +886-2-2267-8000
Fax: +886-2-2267-2261

Europe
Apacer Technology B.V.
Tel: +31-40-267-0000
Fax: +31-40-290-0686

U.S.A.
Apacer Memory America, Inc.
Tel: +1-408-518-8699
Fax: 1-510-249-9551

China
Apacer Electronic(Shanghai)
Co., Ltd.
Tel: +86-21-6228-9939

Japan
Apacer Technology Corp.
Tel: +81-3-5419-2668
Fax: +81-3-5419-0018

India
Apacer Technologies Pvt. Ltd.
Tel: +91-80-41529061~3
Fax: +91-80-41700215