

ServerDOM-L

3ME Series

Customer: _____

Customer

Part

Number: _____

Innodisk

Part

Number: _____

Innodisk

Model Name: _____

Date: _____

Innodisk Approver	Customer Approver

**Total Solution For
Industrial Flash Storage**

Table of contents

LIST OF FIGURES	6
1. PRODUCT OVERVIEW	7
1.1 INTRODUCTION OF INNODISK SERVERDOM-L 3ME	7
1.2 PRODUCT VIEW AND MODELS	7
1.3 SATA INTERFACE	7
2. PRODUCT SPECIFICATIONS	8
2.1 CAPACITY AND DEVICE PARAMETERS	8
2.2 PERFORMANCE	8
2.3 ELECTRICAL SPECIFICATIONS	8
2.3.1 Power Requirement	8
2.3.2 Power Consumption	8
2.4 ENVIRONMENTAL SPECIFICATIONS	8
2.4.1 Temperature Ranges	8
2.4.2 Humidity	9
2.4.3 Shock and Vibration	9
2.4.4 Mean Time between Failures (MTBF)	9
2.5 CE AND FCC COMPATIBILITY	9
2.6 RoHS COMPLIANCE	9
2.7 RELIABILITY	10
2.8 TRANSFER MODE	10
2.9 PIN ASSIGNMENT	10
2.10 MECHANICAL DIMENSIONS	11
2.11 ASSEMBLY WEIGHT	11
2.12 SEEK TIME	11
2.13 HOT PLUG	11
2.14 NAND FLASH MEMORY	12
3. THEORY OF OPERATION	12
3.1 OVERVIEW	12
3.2 SATA III CONTROLLER	12
3.3 ERROR DETECTION AND CORRECTION	12
3.4 WEAR-LEVELING	13
3.5 BAD BLOCKS MANAGEMENT	13
3.6 POWER CYCLING	13
3.7 GARBAGE COLLECTION	13
4. INSTALLATION REQUIREMENTS	14
4.1 SERVERDOM-L 3ME PIN DIRECTIONS	14

4.2 ELECTRICAL CONNECTIONS FOR SERVERDOM-L 3ME	14
4.3 DEVICE DRIVE	14
4.4 PIN8 VCC	14
4.5 POWER CABLE	15
5. PART NUMBER RULE	16

REVISION HISTORY

Revision	Description	Date
Preliminary	First Released	FEB, 2015
1.0	Add CE/FCC certification	AUG, 2015
1.01	Modified performance	SEP, 2015
1.02	Modify performance Add iDataGuard information Modify the part number rule	Dec, 2015

List of Tables

TABLE 1: DEVICE PARAMETERS	8
TABLE 2: PERFORMANCE	8
TABLE 3: INNODISK SERVERDOM-L 3ME POWER REQUIREMENT	8
TABLE 4: POWER CONSUMPTION	8
TABLE 5: TEMPERATURE RANGE FOR SERVERDOM-L 3ME	9
TABLE 6: SHOCK/VIBRATION TESTING FOR SERVERDOM-L 3ME	9
TABLE 7: SERVERDOM-L 3ME MTBF	9
TABLE 8: INNODISK SERVERDOM-L 3ME PIN ASSIGNMENT	10

List of Figures

FIGURE 1: INNODISK SERVERDOM-L 3ME	7
FIGURE 2: INNODISK SERVERDOM-L 3ME BLOCK DIAGRAM	12
FIGURE 3: SATA SIGNAL SEGMENT & HOST MALE PIN8 SIGNAL SEGMENT	14

1. Product Overview

1.1 Introduction of Innodisk ServerDOM-L 3ME

Innodisk ServerDOM is dedicated to the further of server design. By using ServerDOM as a boot drive, there is more space for the hot-swappable data storage devices.

Innodisk ServerDOM supports SATA III standard (6.0Gb/s) interface with excellent performance and the innovative Pin8 uses the SATA connector itself as a power supply to drive the device without external cables. It could be connected directly to the SATA on-board socket on customers' system without additional power cable. Besides, the booting time for operation and the power consumption is less than hard disk drive (HDD), and can work under harsh environment compile with ATA protocol, no additional drives are required, and the SSD can be configured as a boot device or data storage device.

1.2 Product View and Models

Innodisk ServerDOM-L 3ME is available in follow capacities~

ServerDOM-L 3ME 8GB, 16GB, 32GB, 64GB



Figure 1: Innodisk ServerDOM-L 3ME

1.3 SATA Interface

Innodisk ServerDOM-L 3ME supports SATA III interface, and compliant with SATA I and SATA II. SATA III interface can work with Serial Attached SCSI (SAS) host system, which is used in server computer. Innodisk ServerDOM-L 3ME is compliant with Serial ATA Gen 1, Gen 2 and Gen 3 specification (Gen 3 supports 1.5Gbps /3.0Gbps/6.0Gbps data rate). SATA connector uses a standard 7-pin signal segment.

2. Product Specifications

2.1 Capacity and Device Parameters

ServerDOM-L 3ME device parameters are shown in Table 1.

Table 1: Device parameters

Item	Capacity	Cylinder	Head	Sector	LBA
ServerDOM 3ME	8GB	16	63	13587	13695696
	16GB	16	63	16383	29323728
	32GB	16	63	16383	60579792
	64GB	16	63	16383	121138416

2.2 Performance

Burst Transfer Rate: 6.0Gbps

Table 2: Performance

Item		8GB	16GB	32GB	64GB
ServerDOM 3ME	Sequential Read	120 MB/s	240 MB/s	440 MB/s	480 MB/s
	Sequential Write	20 MB/s	40 MB/s	80 MB/s	160 MB/s

Note: the information is based on CrystalDiskMark 3.01 with file size 1000MB test patent

2.3 Electrical Specifications

2.3.1 Power Requirement

Table 3: Innodisk ServerDOM-L 3ME Power Requirement

Item	Symbol	Rating	Unit
Input voltage	V _{IN}	+5 DC +- 5%	V

2.3.2 Power Consumption

Table 4: Power Consumption

Item	MLC	MLC	MLC	MLC
	8GB	16GB	32GB	64GB
Read (W)	1.4	1.8	2.2	2.5
Write(W)	1.4	1.5	1.9	2.8
Idle(W)	0.9	1.0	1.0	1.0

2.4 Environmental Specifications

2.4.1 Temperature Ranges

Table 5: Temperature range for ServerDOM-L 3ME

Temperature	Range
Operating	Standard Grade: 0°C to +70°C
Storage	-55°C to +95°C

2.4.2 Humidity

Relative Humidity: 10-95%, non-condensing

2.4.3 Shock and Vibration

Table 6: Shock/Vibration Testing for ServerDOM-L 3ME

Reliability	Test Conditions	Reference Standards
Vibration	7 Hz to 2K Hz, 20G, 3 axes	IEC 68-2-6
Mechanical Shock	Duration: 0.5ms, 1500 G, 3 axes	IEC 68-2-27

2.4.4 Mean Time between Failures (MTBF)

Table 7 summarizes the MTBF prediction results for various ServerDOM-L 3ME configurations. The analysis was performed using a RAM Commander™ failure rate prediction.

- **Failure Rate:** The total number of failures within an item population, divided by the total number of life units expended by that population, during a particular measurement interval under stated condition.
- **Mean Time between Failures (MTBF):** A basic measure of reliability for repairable items: The mean number of life units during which all parts of the item perform within their specified limits, during a particular measurement interval under stated conditions.

Table 7: ServerDOM-L 3ME MTBF

Product	Condition	MTBF (Hours)
Innodisk ServerDOM-L 3ME	Telcordia SR-332 GB, 25°C	>3,000,000

2.5 CE and FCC Compatibility

ServerDOM-L 3ME conforms to CE and FCC requirements.

2.6 RoHS Compliance

ServerDOM-L 3ME is fully compliant with RoHS directive.

2.7 Reliability

Parameter	Value
Read Cycles	Unlimited Read Cycles
Wear-Leveling Algorithm	Support
Bad Blocks Management	Support
Error Correct Code	Support

Item	MLC 8GB	MLC 16GB	MLC 32GB	MLC 64GB
TBW(TB) (Sequential)	21.6	43.2	86.4	172.8

2.8 Transfer Mode

ServerDOM-L 3ME support following transfer mode:

Serial ATA III 6.0Gbps

Serial ATA II 3.0Gbps

Serial ATA I 1.5Gbps

2.9 Pin Assignment

Innodisk ServerDOM-L 3ME uses a standard SATA pin-out. See Table 8 for ServerDOM-L 3ME pin assignment.

Table 8: Innodisk ServerDOM-L 3ME Pin Assignment

Name	Type	Description
Pin 0	GND	Shielding
Pin 1	GND	Shielding
Pin 2	A+	Differential signal to A
Pin 3	A-	Differential signal to A-
Pin 4	GND	Shielding
Pin 5	B-	Differential signal to B-
Pin 6	B+	Differential signal to B
Pin 7	GND/VCC	Shielding/ Power*
Pin 8	VCC (+5V)	Power

*Note: Pin7 with power supply version is provided with different model and PN, which request specific M/B designed with 5V power supply through SATA port(7th pin) and cannot use external cable for power supply!

2.10 Mechanical Dimensions

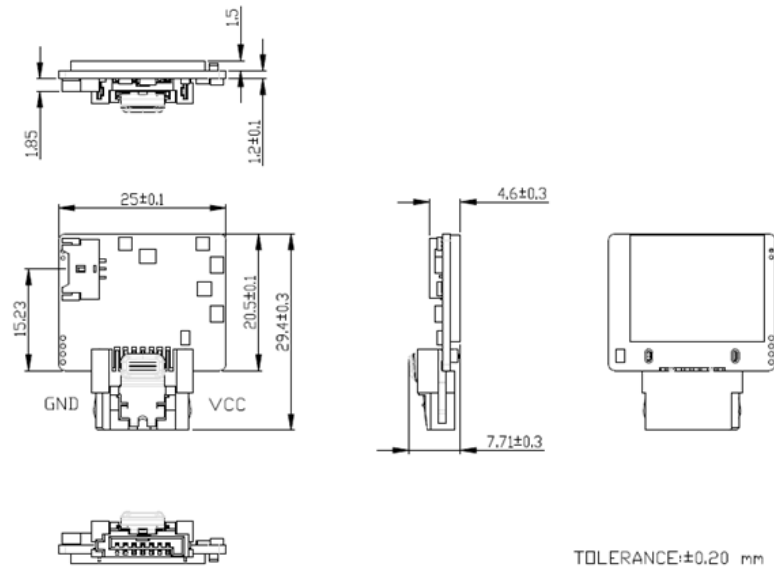

2.11 Assembly Weight

An Innodisk ServerDOM-L 3ME within flash ICs, 64GB's weight is 8 grams approximately.

2.12 Seek Time

Innodisk ServerDOM-L 3ME is not a magnetic rotating design. There is no seek or rotational latency required.

2.13 Hot Plug

The SSD support hot plug function and can be removed or plugged-in during operation. User has to avoid hot plugging the SSD which is configured as boot device and installed operation system.

Surprise hot plug : The insertion of a SATA device into a backplane (combine signal and power) that has power present. The device powers up and initiates an OOB sequence.

Surprise hot removal: The removal of a SATA device from a powered backplane, without first being placed in a quiescent state.

2.14 NAND Flash Memory

Innodisk ServerDOM-L 3ME uses NAND flash memory, which is non-volatile, high reliability and high speed memory storage. Each cell stores 1~2 bits or holds four states per cell. Read or Write data to flash memory for SSD is controlled by microprocessor.

3. Theory of Operation

3.1 Overview

Figure 2 shows the operation of Innodisk ServerDOM-L 3ME from the system level, including the major hardware blocks.

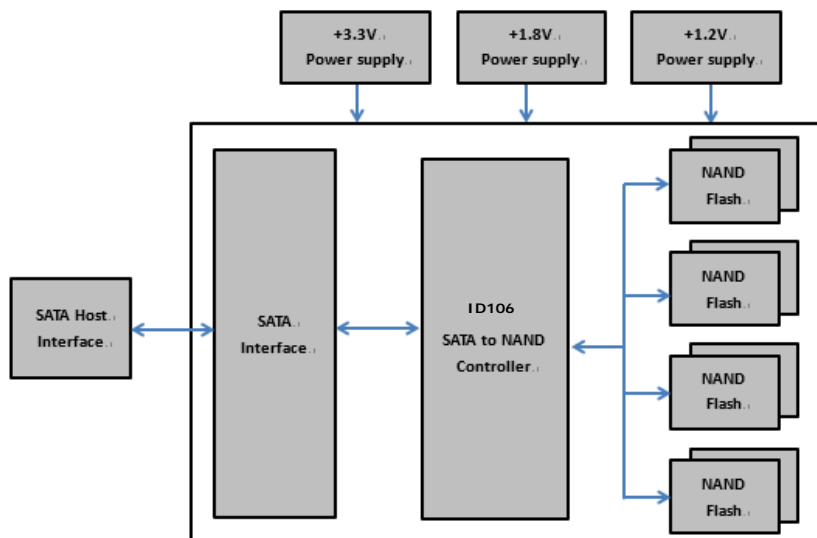

Figure 2: Innodisk ServerDOM-L 3ME Block Diagram

Innodisk ServerDOM-L 3ME integrates a SATA III controller and NAND flash memories. Communication with the host occurs through the host interface, using the standard ATA protocol. Communication with the flash device(s) occurs through the flash interface.

3.2 SATA III Controller

Innodisk ServerDOM-L 3ME is designed with ID 106, a SATA III 6.0Gbps (Gen. 3) controller. The Serial ATA physical, link and transport layers are compliant with Serial ATA Gen 1, Gen 2 and Gen 3 specification (Gen 3 supports 1.5Gbps/3.0Gbps/6.0Gbps data rate). The controller has 2 channels for flash interface.

3.3 Error Detection and Correction

Highly sophisticated Error Correction Code algorithms are implemented. The ECC unit consists of the Parity Unit (parity-byte generation) and the Syndrome Unit (syndrome-byte computation).

This unit implements an algorithm that can correct 40 bits per 1024 bytes in an ECC block. Code-byte generation during write operations, as well as error detection during read operation, is implemented on the fly without any speed penalties.

3.4 Wear-Leveling

Flash memory can be erased within a limited number of times. This number is called the **erase cycle limit** or **write endurance limit** and is defined by the flash array vendor. The erase cycle limit applies to each individual erase block in the flash device.

Innodisk ServerDOM-L 3ME uses a static wear-leveling algorithm to ensure that consecutive writes of a specific sector are not written physically to the same page/block in the flash. This spreads flash media usage evenly across all pages, thereby extending flash lifetime.

3.5 Bad Blocks Management

Bad Blocks are blocks that contain one or more invalid bits whose reliability are not guaranteed. The Bad Blocks may be presented while the SSD is shipped, or may develop during the life time of the SSD. When the Bad Blocks is detected, it will be flagged, and not be used anymore. The SSD implement Bad Blocks management, Bad Blocks replacement, Error Correct Code to avoid data error occurred. The functions will be enabled automatically to transfer data from Bad Blocks to spare blocks, and correct error bit.

3.6 Power Cycling

Innodisk's iDataGuard is a comprehensive data protection mechanism that functions before and after a sudden power outage to SSD. Low-power detection terminates data writing before an abnormal power-off, while table-remapping after power-on deletes corrupt data and maintains data integrity. Innodisk's iDataGuard provides effective power cycling management, preventing data stored in flash from degrading with use.

3.7 Garbage Collection

Garbage collection is used to maintain data consistency and perform continual data cleansing on SSDs. It runs as a background process, freeing up valuable controller resources while sorting good data into available blocks, and deleting bad blocks. It also significantly reduces write operations to the drive, thereby increasing the SSD's speed and lifespan.

4. Installation Requirements

4.1 ServerDOM-L 3ME Pin Directions

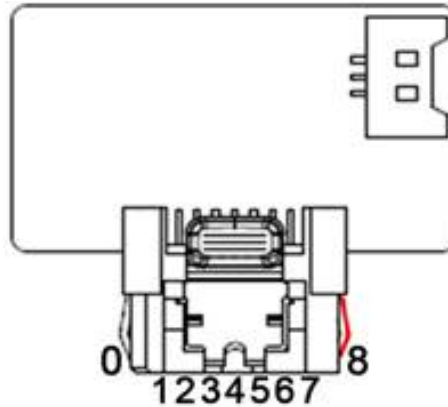

**Default power supply through pin 8 or extra power cable.*

Pin 7 power supply as an optional function with separate PN end of B.

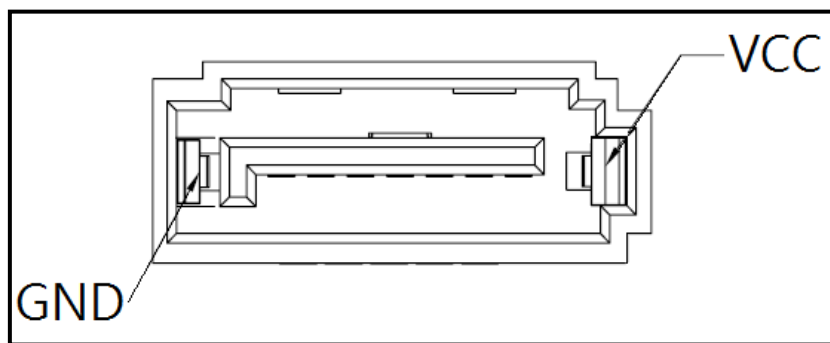

Figure 3: SATA signal segment & Host male Pin8 signal segment

4.2 Electrical Connections for ServerDOM-L 3ME

A Serial ATA device may be either directly connected to a host or connected to a host through a cable. For connection via cable, the cable should be no longer than 1meter. The SATA interface has a separate connector for the power supply. Please refer to the pin description for further details.

4.3 Device Drive

No additional device drives are required. The Innodisk ServerDOM-L 3ME can be configured as a boot device.

4.4 Pin8 VCC

ServerDOM series with Pin8 VCC, it is defined Pin8 as VCC on the SATA connector. Thus the power

would come from SATA connector Pin8 VCC. Customers DO NOT have to use the power cable for power supply. Such a wireless design of ServerDOM series with Pin8 VCC brings more convenience to customers' system. The followings are the points customers have to be careful of while designing in ServerDOM series with Pin8 VCC.

When customers use ServerDOM with Pin8 VCC and the host SATA socket does not have power on Pin8, external power must be provided to the ServerDOM from the 3pin connector on the side. To have the advantages of ServerDOM series with Pin8 VCC, and to avoid any potential damage to customers' board designed with VCC power supply, Innodisk suggests that customers MUST design their board with a fuse which should be designed before the SATA socket Pin8 VCC. In other words, customers are suggested NOT TO layout 5V VCC to SATA socket on board directly. A circuit diagram example to explain this is shown as below.

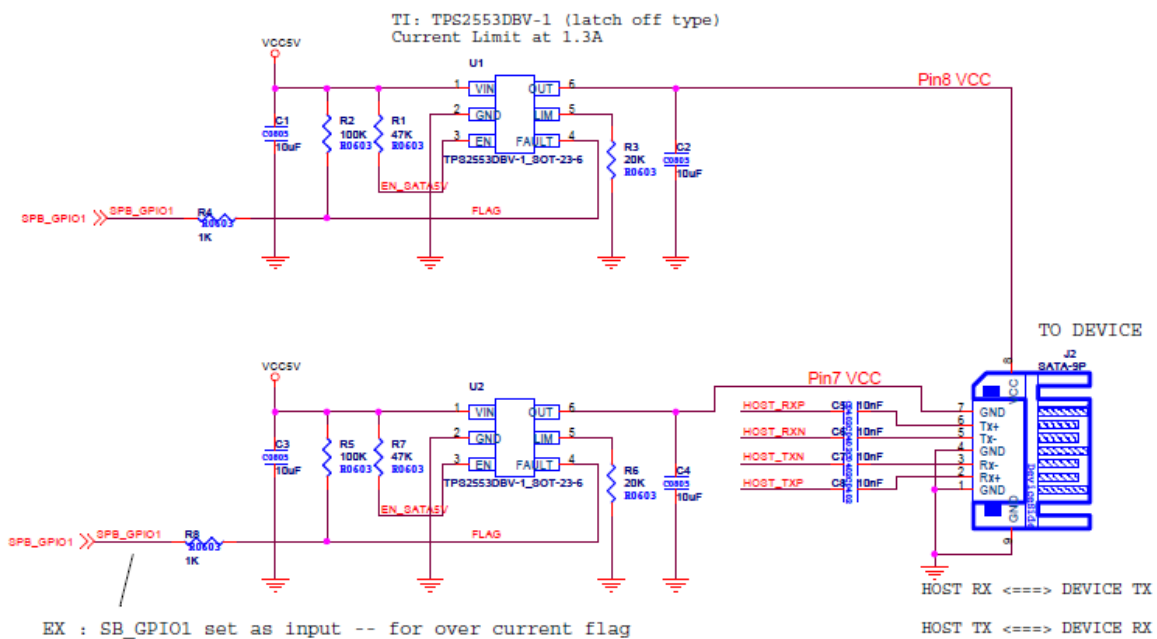

4.5 Power cable

A power cable is shipped with each SATADOM product, which has standard 4pins power connector and special 3 pins power connector for SATADOM. The male and female power connector of SATADOM have foolproof design to avoid misconnection, please check it before power on.

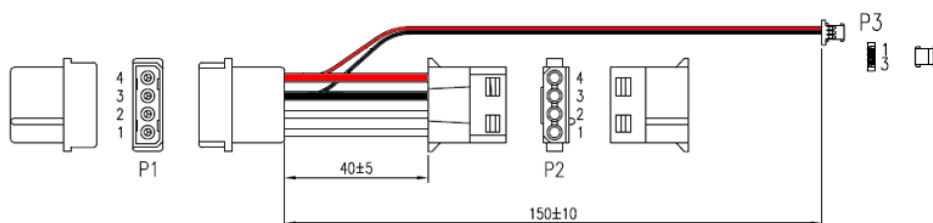

* The item part number end with "B" mean power supply version, Which doesn't provide power cable.

5. Part Number Rule

CODE	1	2	3	4	5	6	7	8	9	10	11	12	13	14	15	16	17	18	19	20	21	22
	D	E	S	N	L	-	3	2	G	D	0	6	S	C	A	Q	Y	A	-	X	X	X
Description	Disk	ServerDOM				Capacity			Controller			Flash Mode	Operation Temp.	Internal Control	CH.	Flash Type	Pin Type	-	Customized Code			
Definition																						
Code 1st (Disk)											Code 14th (Operation Temperature)											
D : Disk											C: Standard Grade (0°C~ +70°C)											
Code 2nd (Feature set)																						
E : Embedded Series H: ISLC Series											Code 15th (Internal control)											
Code 3rd ~5th (Form factor)											A~Z: PCB version.											
SNL: ServerDOM-L (Low profile)											Code 16th (Channel of data transfer)											
Code 7th ~9th (Capacity)											S: Single Channel											
08G: 8GB, 16G: 16GB 32G: 32GB, 64G: 64GB											D: Dual Channels											
											Q: Quad Channels											
											Code 17th (Flash Type)											
											Y: MLC X: SLC											
Code 10th ~12th (Controller)											Code 18th (pin7/pin8 type)											
D06: ID106											A: Pin8 version B: Pin8+Pin7 version											
Code 13th (Flash mode)											Code 19th~21st (Customize code)											
Internal control.																						

Appendix

CE/FCC/RoHS

Certificate

Issue Date: June 15, 2015
Ref. Report No. ISL-15LE242CE

Product Name : ServerDOM-L
Model(s) : ServerDOM-L 3\$*@
(\$:Flash type: (S:SLC,I:iSLC,M:MLC);
*: Product line: (E:Embedded, G: EverGreen, R: InnoRobust);
@: non: Gen1, 2: Gen 2, 3: Gen 3)
Responsible Party : Innodisk Corporation
Address : 5F.No.237, Sec. 1, Datong Rd., Xizhi Dist., New Taipei City 221, Taiwan
(R.O.C.)

We, **International Standards Laboratory**, hereby certify that:

The device bearing the trade name and model specified above has been shown to comply with the applicable technical standards as indicated in the measurement report and was tested in accordance with the measurement procedures specified in European Council Directive- EMC Directive 2004/108/EC. The device was passed the test performed according to :



Standards:

EN 55022: 2010+AC2011 and CISPR 22: 2008 (modified)
EN 61000-3-2: 2006+A1:2009 +A2:2009 and IEC 61000-3-2: 2005+A1:2008 +A2:2009
EN 61000-3-3: 2013 and IEC 61000-3-3: 2013
EN 55024: 2010 and CISPR 24: 2010
EN 61000-4-2: 2009 and IEC 61000-4-2: 2008
EN 61000-4-3: 2006+A1: 2008 +A2: 2010 and
IEC 61000-4-3:2006+A1: 2007+A2: 2010
EN 61000-4-4:2012 and IEC 61000-4-4:2012

I attest to the accuracy of data and all measurements reported herein were performed by me or were made under my supervision and are correct to the best of my knowledge and belief. I assume full responsibility for the completeness of these measurements and vouch for the qualifications of all persons taking them.

International Standards Laboratory

Jim Chu / Director

Hsi-Chih LAB:

No. 65, Gu Dai Keng Street, Hsi-Chih Dist.,
New Taipei City 221, Taiwan
Tel: 886-2-2646-2550; Fax: 886-2-2646-4641



Lung-Tan LAB:

No. 120, Lane 180, Hsin Ho Rd., Lung-Tan Dist.,
Tao Yuan City 325, Taiwan
Tel: 886-3-407-1718; Fax: 886-3-407-1738



Certificate

Issue Date: June 15, 2015
Ref. Report No. ISL-15LE242FB

Product Name : ServerDOM-L
Model(s) : ServerDOM-L 3\$*@
(\$:Flash type: (S:SLC,I:iSLC,M:MLC);
*: Product line: (E:Embedded, G: EverGreen, R: InnoRobust);
@: non: Gen1, 2: Gen 2, 3: Gen 3)
Applicant : Innodisk Corporation
Address : 5F.No.237, Sec. 1, Datong Rd., Xizhi Dist., New Taipei City 221, Taiwan
(R.O.C.)

We, **International Standards Laboratory**, hereby certify that:

The device bearing the trade name and model specified above has been shown to comply with the applicable technical standards as indicated in the measurement report and was tested in accordance with the measurement procedures specified. (refer to Test Report if any modifications were made for compliance).



Standards:

FCC CFR Title 47 Part 15 Subpart B: 2012- Section 15.107 and 15.109
ANSI C63.4-2009
Industry Canada Interference-Causing Equipment Standard ICES-003 Issue 5: 2012

Class B

I attest to the accuracy of data and all measurements reported herein were performed by me or were made under my supervision and are correct to the best of my knowledge and belief. I assume full responsibility for the completeness of these measurements and vouch for the qualifications of all persons taking them.

International Standards Laboratory

Jim Chu
Jim Chu / Director

Hsi-Chih LAB:
No. 65, Gu Dai Keng Street, Hsi-Chih Dist.,
New Taipei City 221, Taiwan
Tel: 886-2-2646-2550; Fax: 886-2-2646-4641



Lung-Tan LAB:
No. 120, Lane 180, Hsin Ho Rd., Lung-Tan Dist.,
Tao Yuan City 325, Taiwan
Tel: 886-3-407-1718; Fax: 886-3407-1738



RoHS 自我宣告書 (RoHS Declaration of Conformity)

Manufacturer Product: All Innodisk EM Flash and Dram products

宜鼎國際股份有限公司（以下稱本公司）特此保證售予貴公司之所有產品，皆符合歐盟 2011/65/EU 關於 RoHS 之規範要求。

InnoDisk Corporation declares that all products sold to the company, are complied with European Union RoHS Directive (2011/65/EU) requirement

一、本公司同意因本保證書或與本保證書相關事宜有所爭議時，雙方宜友好協商，達成協議。

InnoDisk Corporation agrees that both parties shall settle any dispute arising from or in connection with this Declaration of Conformity by friendly negotiations.

Name of hazardous substance	Limited of RoHS ppm (mg/kg)
Cd	< 100 ppm
Pb	< 1000 ppm
Hg	< 1000 ppm
Chromium VI (Cr+6)	< 1000 ppm
Polybromodiphenyl ether (PBDE)	< 1000 ppm
Polybrominated Biphenyls (PBB)	< 1000 ppm

立保證書人

Company name 公司名稱：InnoDisk Corporation 宜鼎國際股份有限公司

Company Representative 公司代表人：Richard Lee 李鐘亮

Company Representative Title 公司代表人職稱：CEO 執行長

Date 日期：2013 / 09 / 25



innodisk

宜鼎國際股份有限公司 Innodisk Corporation

Tel:(02)2696-3000 Fax:(02)2696-2000 Internet: <http://www.innodisk.com/>

REACH Declaration of Conformity

Manufacturer Products: All Innodisk EM Flash and Dram products

1. 宜鼎國際股份有限公司（以下稱本公司）特此保證此售予貴公司之產品，皆符合歐盟化學品法案(Registration, Evaluation and Authorization of Chemicals; REACH)之規定 (<http://www.echa.europa.eu/de/candidate-list-table> last updated: 16/12/2013)。所提供之產品包含：(1) 產品或產品所使用到的所有原物料；(2) 包裝材料；(3) 設計、生產及重工過程中所使用到的所有原物料。

We Innodisk Corporation hereby declare that our products are in compliance with the requirements according to the REACH Regulation

(<http://www.echa.europa.eu/de/candidate-list-table> last updated: 16/12/2013).

Products include: 1) Product and raw material used by the product; 2) Packaging material; 3) Raw material used in the process of design, production and rework

2. 本公司同意因本保證書或與本保證書相關事宜有所爭議時，雙方宜友好協商，達成協議。

InnoDisk Corporation agrees that both parties shall settle any dispute arising from or in connection with this Declaration of Conformity by friendly negotiations.

立保證書人 (Guarantor)

Company name 公司名稱: InnoDisk Corporation 宜鼎國際股份有限公司

Address: 9F, No. 100, Sec.1 Xintai 5th Rd., Xizhi Dist., New Taipei City 221, Taiwan

Company Representative 公司代表人: Richard Lee 李鐘亮

Company Representative Title 公司代表人職稱: CEO 執行長

Date 日期: 2014 / 03 / 18

