

W12L100-GSB1

12.3" G-WIN GS Series Display



KEY FEATURES

- 12.3" 1920 x 720 panel
- Projected Capacitive Multi-Touch (PCAP)
- Full IP65 Water and Dust Proof
- VGA input and USB port for touch
- M12 Type Connectors
- Compliant with MIL-STD-810F/G for Shock / Vibration



SPECIFICATIONS

Display	
Resolution	1920x720
Contrast Ratio	1000:1
Display Color	16.7M Colors
Type	Projected Capacitive Multi Touch
Size	12.3 inches
Panel Brightness	1000.0 nits
View Angles	88,88,88,88
Environment	
Operating Humidity	10% to 95% RH
Storage Temperature	-30°C to 60°C
Vibration	1.48/1.90/2.24 g rms for XYZ/ 5-500Hz
Operating Temperature	-15~55°C
Shock	40g for 11ms
IP rating	IP65, Dustproof and Waterproof
Certification	
Certification	CE, FCC Compliant with MIL-STD-810F/G for vibration / shock
IO Ports	
USB Port	1 x USB for Touch Screen
Audio	1 x Speaker
Video	1 x VGA
Mechanical	
Dimension	325.02 x 146.5 x 44.9 mm
Enclosure	Metal Housing with Aluminum Bezel
Mounting	VESA Mount/ Panel Mount
Cooling System	Fanless Design
Accessory	
Accessory	Quick Start Guide(Hardcopy) AC Adapter(For 7" Display only) M12 Power Cable(Not Supplied with 7" Display) VGA Cable USB for Touch Cable I/O Protective Cap x 3
Power	
Power Rating	12V DC (M12 type)
Control	
Button	5 Keys: -, +, Power, Esc, Enter

DIMENSIONS UNIT:MM

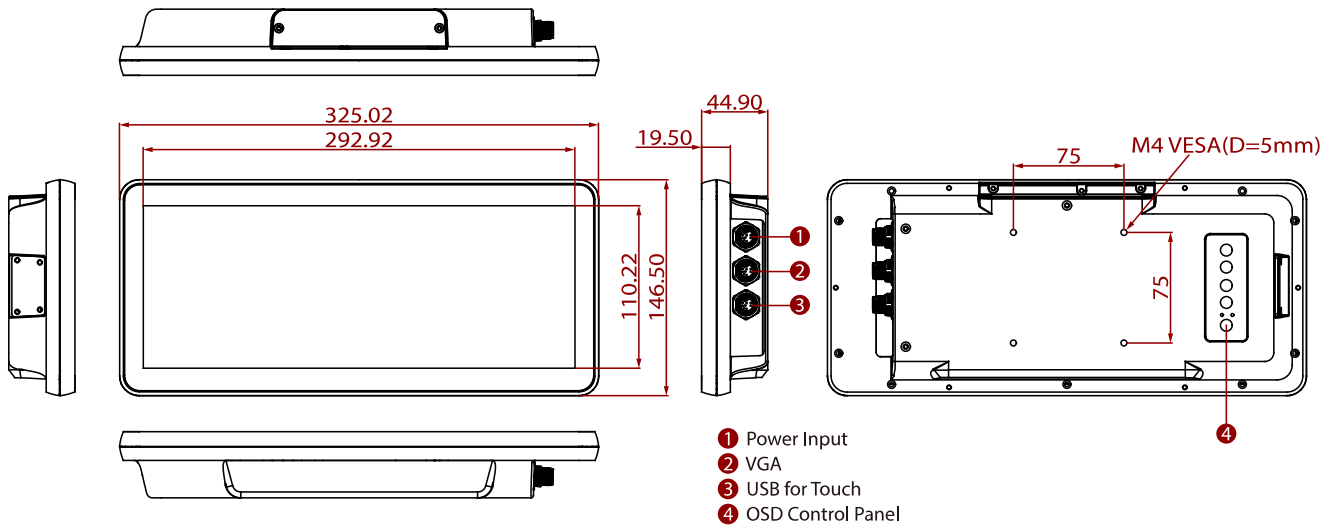

NOTE

- 1.This is a simplified drawing and some components are not marked in detail.
- 2.Please contact our sales representative if you need further product information.
- 3.All specifications are subject to change without prior notice.
- 4.The product shown in this datasheet is a standard model.For diagrams that contain customized or optional I/ O, please contact the Winmate Sales Team for more information.