

G101M9

10.1" ARM A73 + A53 Rugged Handheld Controller



KEY FEATURES

- Low Latency video SW decoder for real-time high-resolution video viewing
- All-weather, dust, and water-resistant design (IP65). MIL-grade drop, Shock and vibration
- Supports optional WIFI, BT and 4G
- With dual antennas, providing improved wireless connectivity and stability
- With a removable second battery and a battery life of over 10 hours is a must-have tool for serious UAV pilots



SPECIFICATIONS

Display			
Resolution	1920x1200	Size	10.1 inches
Contrast Ratio	800:1	Panel Brightness	800.0 nits
View Angles	85,85,85,85	Bonding	Optical Bonding for Sunlight Viewability
Type	Projected Capacitive Multi Touch	Viewability	Anti-Glare touch treatment
Touch Mode	Support Hand / Gloves and Rain Mode		
System Specification			
Processor	ARM A73 x 4 (2.0 GHz) + A53 x 4 (2.0 GHz)	Memory	4GB
Storage	32GB	Operating System	Android 11.0 Linux Ubuntu 22.04 (Optional)
WLAN	Support	BT	Support
WWAN	4G/LTE (Optional)	GNSS	GPS/GLONASS
Sensors	Ambient Light Sensor, E-Compass, Gyro, Acceleration Sensors		
Camera			
Front Camera	8MP Camera	Rear Camera	13MP Camera with LED Auxiliary Light (Auto Focus)
Mechanical			
Dimension	366 x 219 x 49.5 mm	Cooling System	Fan Design
IO Ports			
USB Port	1 x USB 2.0	Video	1 x HDMI output
Audio	1x Speaker		
Environment			
Operating Humidity	10% to 90% RH, non-condensing	Operating Temperature	-20°C to 60°C (AC mode), -10°C to 50°C (Battery mode)
Storage Temperature	-30°C to 70°C (-22°F to 158°F)	Shock	MIL-STD-810H Method 516.8 Procedure I
Vibration	MIL-STD-810H Method 514.8 Procedure I	IP rating	IP65
Certification			
Certification	CE, FCC		

Security Function			
SOTI MobiControl	SOTI MobiControl Compliance	Kensington Lock	Kensington Lock Support
Control			
Button	Left Side: 1x joystick 2x roller switch 1x 2 band toggle switch 1x button (front side) 1x control button (rear side) Right Side: 1x joystick 1x roller switch 1x camera button 1x power button 1x 2 band toggle switch 1x button (front side) 1x control button (rear side)		
Power			
Battery	11.4V, typ. 3500 mAh Lilon Rechargeable Internal Battery (3S1P) 11.4V, typ. 3500 mAh Lilon Rechargeable Secondary Battery (3S1P)	Power Rating	19V DC
Adapter	100-240V, 50-60Hz / 19V DC		
Accessory			
Accessory	Adapter and Power Cord	Optional Accessory	Battery Charger (Optional) Stylus (Optional)
Communication Link			
Antenna	2x 3dBi Antennas	Frequency	2.4GHz
Output Power	1W, Adjustable		

DIMENSIONS UNIT:MM

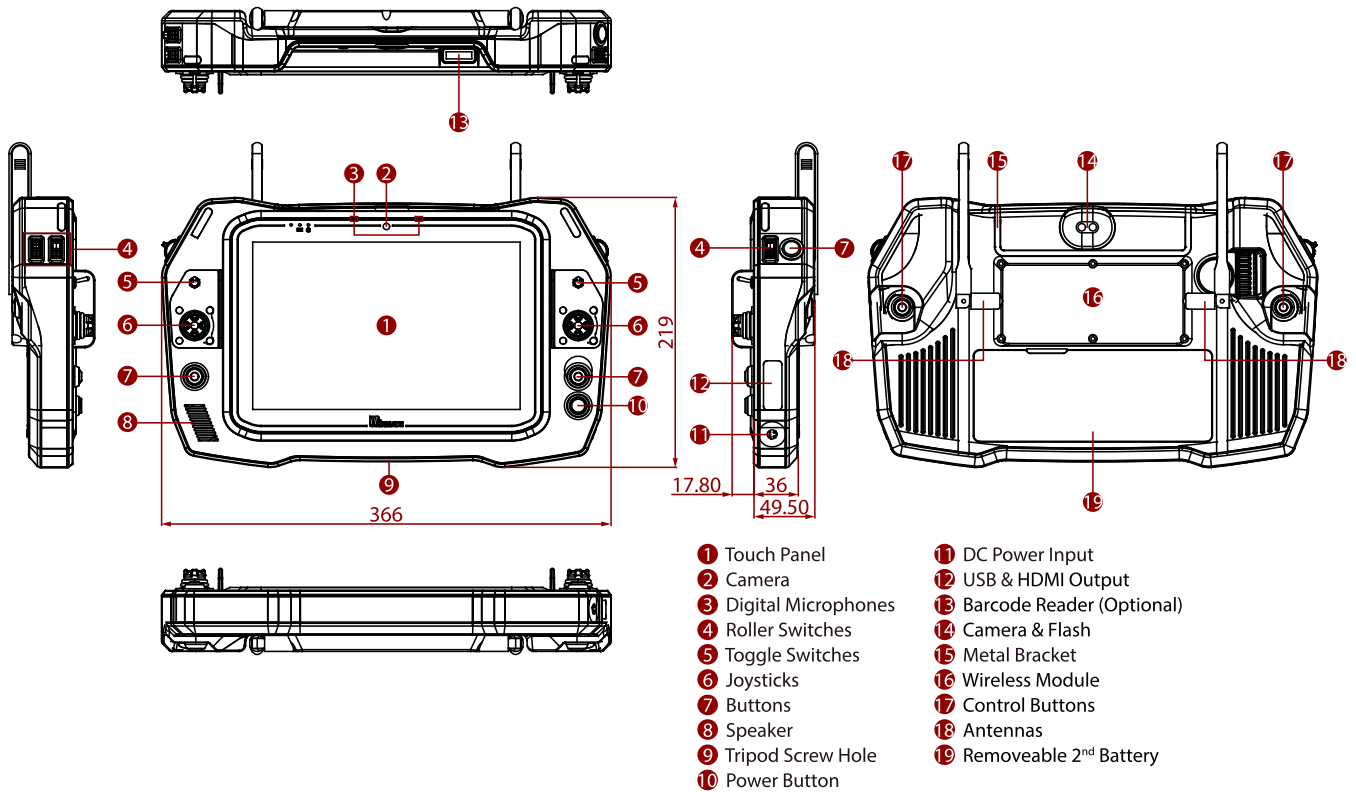

NOTE

- 1.This is a simplified drawing and some components are not marked in detail.
- 2.Please contact our sales representative if you need further product information.
- 3.All specifications are subject to change without prior notice.
- 4.The product shown in this datasheet is a standard model.For diagrams that contain customized or optional I/ O, please contact the Winmate Sales Team for more information.