

# M.2 (S42)

## 3ME2 Series

**Customer:** \_\_\_\_\_

**Customer**

**Part**

**Number:** \_\_\_\_\_

**Innodisk**

**Part**

**Number:** \_\_\_\_\_

**Innodisk**

**Model Name:** \_\_\_\_\_

**Date:** \_\_\_\_\_

<b>Innodisk Approver</b>	<b>Customer Approver</b>

**Total Solution For  
Industrial Flash Storage**

## Table of contents

<b>LIST OF FIGURES</b> .....	<b>6</b>
<b>1. PRODUCT OVERVIEW</b> .....	<b>7</b>
<b>1.1 INTRODUCTION OF INNODISK M.2 (S42) 3ME2</b> .....	<b>7</b>
<b>1.2 PRODUCT VIEW AND MODELS</b> .....	<b>7</b>
<b>1.3 SATA INTERFACE</b> .....	<b>7</b>
<b>2. PRODUCT SPECIFICATIONS</b> .....	<b>8</b>
<b>2.1 CAPACITY AND DEVICE PARAMETERS</b> .....	<b>8</b>
<b>2.2 PERFORMANCE</b> .....	<b>8</b>
<b>2.3 ELECTRICAL SPECIFICATIONS</b> .....	<b>8</b>
<b>2.3.1 Power Requirement</b> .....	<b>8</b>
<b>2.3.2 Power Consumption</b> .....	<b>9</b>
<b>2.4 ENVIRONMENTAL SPECIFICATIONS</b> .....	<b>9</b>
<b>2.4.1 Temperature Ranges</b> .....	<b>9</b>
<b>2.4.2 Humidity</b> .....	<b>9</b>
<b>2.4.3 Shock and Vibration</b> .....	<b>9</b>
<b>2.4.4 Mean Time between Failures (MTBF)</b> .....	<b>9</b>
<b>2.5 CE AND FCC COMPATIBILITY</b> .....	<b>10</b>
<b>2.6 RoHS COMPLIANCE</b> .....	<b>10</b>
<b>2.7 RELIABILITY</b> .....	<b>10</b>
<b>2.8 TRANSFER MODE</b> .....	<b>10</b>
<b>2.9 PIN ASSIGNMENT</b> .....	<b>11</b>
<b>2.10 MECHANICAL DIMENSIONS</b> .....	<b>13</b>
<b>2.11 ASSEMBLY WEIGHT</b> .....	<b>13</b>
<b>2.12 SEEK TIME</b> .....	<b>13</b>
<b>2.13 HOT PLUG</b> .....	<b>13</b>
<b>2.14 NAND FLASH MEMORY</b> .....	<b>13</b>
<b>3. THEORY OF OPERATION</b> .....	<b>14</b>
<b>3.1 OVERVIEW</b> .....	<b>14</b>
<b>3.2 SATA III CONTROLLER</b> .....	<b>14</b>
<b>3.3 ERROR DETECTION AND CORRECTION</b> .....	<b>15</b>
<b>3.4 WEAR-LEVELING</b> .....	<b>15</b>
<b>3.5 BAD BLOCKS MANAGEMENT</b> .....	<b>15</b>
<b>3.6 POWER CYCLING</b> .....	<b>15</b>
<b>3.7 GARBAGE COLLECTION</b> .....	<b>15</b>
<b>4. INSTALLATION REQUIREMENTS</b> .....	<b>16</b>
<b>4.1 M.2 (S42) 3ME2 PIN DIRECTIONS</b> .....	<b>16</b>

<b>4.2 ELECTRICAL CONNECTIONS FOR M.2 (S42) 3ME2 .....</b>	<b>16</b>
<b>4.3 DEVICE DRIVE .....</b>	<b>16</b>
<b>5. PART NUMBER RULE .....</b>	<b>17</b>

## REVISION HISTORY

Revision	Description	Date
Preliminary	First Released	July, 2015
Rev 1.0	Official Released	December, 2015

## List of Tables

<b>TABLE 1: DEVICE PARAMETERS</b> .....	8
<b>TABLE 2: PERFORMANCE</b> .....	8
<b>TABLE 3: INNODISK M.2 (S42) 3ME2 POWER REQUIREMENT</b> .....	8
<b>TABLE 4: POWER CONSUMPTION</b> .....	9
<b>TABLE 5: TEMPERATURE RANGE FOR M.2 (S42) 3ME2</b> .....	9
<b>TABLE 6: SHOCK/VIBRATION TESTING FOR M.2 (S42) 3ME2</b> .....	9
<b>TABLE 7: M.2 (S42) 3ME2 MTBF</b> .....	10
<b>TABLE 8: INNODISK M.2 (S42) 3ME2 PIN ASSIGNMENT</b> .....	11

## List of Figures

<b>FIGURE 1: INNODISK M.2 (S42) 3ME2</b> .....	7
<b>FIGURE 2: INNODISK M.2 (S42) 3ME2 BLOCK DIAGRAM</b> .....	14
<b>FIGURE 3: SIGNAL SEGMENT AND POWER SEGMENT</b> .....	16

# 1. Product Overview

## 1.1 Introduction of Innodisk M.2 (S42) 3ME2

Innodisk M.2 (S42) 3ME2 is designed as the standard M.2 form factor with SATA interface, and supports SATA III standard (6.0Gb/s) with excellent performance. The form factor refers to the M.2(NGFF) specification which established by JEDEC. Regarding of mechanical interference, Innodisk M.2 (S42) 3ME2 absolutely replaces the traditional hard disk and makes personal computer, in any field, smaller and easier.

Innodisk M.2 (S42) 3ME2 effectively reduces the booting time of operation system and the power consumption is less than hard disk drive (HDD), and complies with ATA protocol, no additional drives are required, and can be configured as a boot device or data storage device

## 1.2 Product View and Models

Innodisk M.2 (S42) 3ME2 is available in follow capacities within MLC flash ICs.

[M.2 \(S42\) 3ME2 16GB \(type 2242\)](#)

[M.2 \(S42\) 3ME2 32GB \(type 2242\)](#)

[M.2 \(S42\) 3ME2 64GB \(type 2242\)](#)

[M.2 \(S42\) 3ME2 128GB \(type 2242\)](#)

[M.2 \(S42\) 3ME2 256GB \(type 2242\)](#)



**Figure 1: Innodisk M.2 (S42) 3ME2 (type 2242)**

## 1.3 SATA Interface

Innodisk M.2 (S42) 3ME2 supports SATA III interface, and compliant with SATA I and SATA II. SATA III interface can work with Serial Attached SCSI (SAS) host system, which is used in server computer. Innodisk M.2 (S42) 3ME2 is compliant with Serial ATA Gen 1, Gen 2 and Gen 3 specification (Gen 3 supports 1.5Gbps /3.0Gbps/6.0Gbps data rate).

## 2. Product Specifications

### 2.1 Capacity and Device Parameters

M.2 (S42) 3ME2 device parameters are shown in Table 1.

**Table 1: Device parameters**

Capacity	Cylinders	Heads	Sectors	LBA	user space
16GB	16383	16	63	31277232	15,272
32GB	16383	16	63	62533296	30,533
64GB	16383	16	63	125045424	61,057
128GB	16383	16	63	250069680	122,104
256GB	16383	16	63	500118192	244,198

### 2.2 Performance

Burst Transfer Rate: 6.0Gbps

**Table 2: Performance**

Capacity		16GB	32GB	64GB	128GB	256GB
Micron	Sequential* Read (max.)	120 MB/s	250 MB/s	500 MB/s	510 MB/s	510 MB/s
	Sequential* Write (max.)	20 MB/s	40 MB/s	85 MB/s	160 MB/s	160 MB/s
	4KB Random** Read (QD32)	5,600 IOPS	12,000 IOPS	22,200 IOPS	30,200 IOPS	30,700 IOPS
	4KB Random** Write (QD32)	4,800 IOPS	9,900 IOPS	21,000 IOPS	38,400 IOPS	38,400 IOPS

Note: the information is based on CrystalDiskMark 3.01 with file size 1000MB test patent

### 2.3 Electrical Specifications

#### 2.3.1 Power Requirement

**Table 3: Innodisk M.2 (S42) 3ME2 Power Requirement**

Item	Symbol	Rating	Unit
Input voltage	V <sub>IN</sub>	+3.3 DC +- 5%	V



## 2.3.2 Power Consumption

**Table 4: Power Consumption**

Mode	Power Consumption (mA)
Read	316 (max.)
Write	330 (max.)
Idle	68 (max.)

\* Target: 128GB M.2 (S42) 3ME2

## 2.4 Environmental Specifications

### 2.4.1 Temperature Ranges

**Table 5: Temperature range for M.2 (S42) 3ME2**

Temperature	Range
Operating	Standard Grade: 0°C to +70°C
	Industrial Grade: -40°C to +85°C
Storage	-55°C to +95°C

### 2.4.2 Humidity

Relative Humidity: 10-95%, non-condensing

### 2.4.3 Shock and Vibration

**Table 6: Shock/Vibration Testing for M.2 (S42) 3ME2**

Reliability	Test Conditions	Reference Standards
Vibration	7 Hz to 2K Hz, 20G, 3 axes	IEC 68-2-6
Mechanical Shock	Duration: 0.5ms, 1500 G, 3 axes	IEC 68-2-27

### 2.4.4 Mean Time between Failures (MTBF)

Table 7 summarizes the MTBF prediction results for various M.2 (S42) 3ME2 configurations. The analysis was performed using a RAM Commander™ failure rate prediction.

- **Failure Rate:** The total number of failures within an item population, divided by the total number of life units expended by that population, during a particular measurement interval under stated condition.
- **Mean Time between Failures (MTBF):** A basic measure of reliability for repairable items: The mean number of life units during which all parts of the item perform within their specified limits, during a particular measurement interval under stated conditions.

**Table 7: M.2 (S42) 3ME2 MTBF**

Product	Condition	MTBF (Hours)
Innodisk M.2 (S42) 3ME2	Telcordia SR-332 GB, 25°C	>3,000,000

## 2.5 CE and FCC Compatibility

M.2 (S42) 3ME2 conforms to CE and FCC requirements.

## 2.6 RoHS Compliance

M.2 (S42) 3ME2 is fully compliant with RoHS directive.

## 2.7 Reliability

Parameter	Value
Read Cycles	Unlimited Read Cycles
Wear-Leveling Algorithm	Support
Bad Blocks Management	Support
Error Correct Code	Support
iData Guard	Support
Thermal Sensor	WT only
Flash endurance	3,000 P/E cycles
TBW* (Total Bytes Written)	Unit: TB
16GB	4.8
32GB	9.6
64GB	19.2
128GB	38.4
256GB	76.8
* Total bytes written is based on JEDEC 218 (Solid-State Drive Requirements and Endurance Test Method)	
** Lifespan is calculated by device written per day	

## 2.8 Transfer Mode

M.2 (S42) 3ME2 support following transfer mode:

Serial ATA III 6.0Gbps

Serial ATA II 3.0Gbps

Serial ATA I 1.5Gbps

## 2.9 Pin Assignment

Innodisk M.2 (S42) 3ME2 uses a standard SATA pin-out. See Table 8 for M.2 (S42) 3ME2 pin assignment.

**Table 8: Innodisk M.2 (S42) 3ME2 Pin Assignment**

Signal Name	Pin #	Pin #	Signal Name
		75	GND
3.3V	74	73	GND
3.3V	72	71	GND
3.3V	70	69	GND
SUSCLK	68	67	NC
Notch	66	65	Notch
Notch	64	63	Notch
Notch	62	61	Notch
Notch	60	59	Notch
Reserved/ MFG Clock	58		
Reserved/ MFG Data	56	57	GND
NC	54	55	NC
NC	52	53	NC
NC	50	51	GND
NC	48	49	RX+
NC	46	47	RX-
NC	44	45	GND
NC	42	43	TX-
NC	40	41	TX+
DEVSLP	38	39	GND
NC	36	37	NC

NC	34	35	NC
NC	32	33	GND
NC	30	31	NC
NC	28	29	NC
NC	26	27	GND
NC	24	25	NC
NC	22	23	NC
NC	20	21	GND
Notch	18	19	Notch
Notch	16	17	Notch
Notch	14	15	Notch
Notch	12	13	Notch
DAS/DSS	10	11	NC
NC	8	9	NC
NC	6	7	NC
3.3V	4	5	NC
3.3V	2	3	GND
		1	GND

## 2.10 Mechanical Dimensions

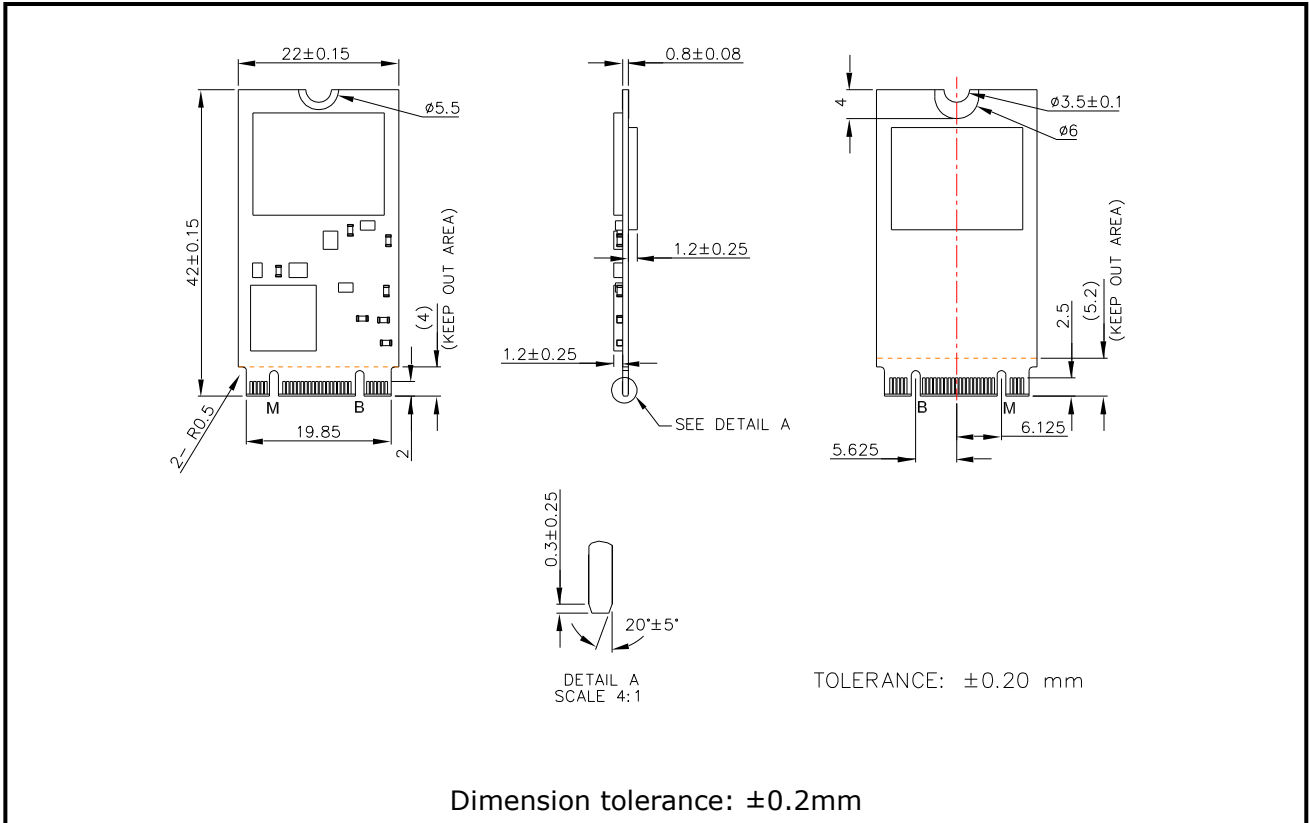

## 2.11 Assembly Weight

An Innodisk M.2 (S42) 3ME2 within flash ICs, 64GB's weight is 8 grams approximately.

## 2.12 Seek Time

Innodisk M.2 (S42) 3ME2 is not a magnetic rotating design. There is no seek or rotational latency required.

## 2.13 Hot Plug

The SSD support hot plug function and can be removed or plugged-in during operation. User has to avoid hot plugging the SSD which is configured as boot device and installed operation system.

**Surprise hot plug** : The insertion of a SATA device into a backplane (combine signal and power) that has power present. The device powers up and initiates an OOB sequence.

**Surprise hot removal:** The removal of a SATA device from a powered backplane, without first being placed in a quiescent state.

## 2.14 NAND Flash Memory

Innodisk M.2 (S42) 3ME2 uses Multi Level Cell (MLC) NAND flash memory, which is non-volatility, high reliability and high speed memory storage.

# 3. Theory of Operation

## 3.1 Overview

Figure 2 shows the operation of Innodisk M.2 (S42) 3ME2 from the system level, including the major hardware blocks.

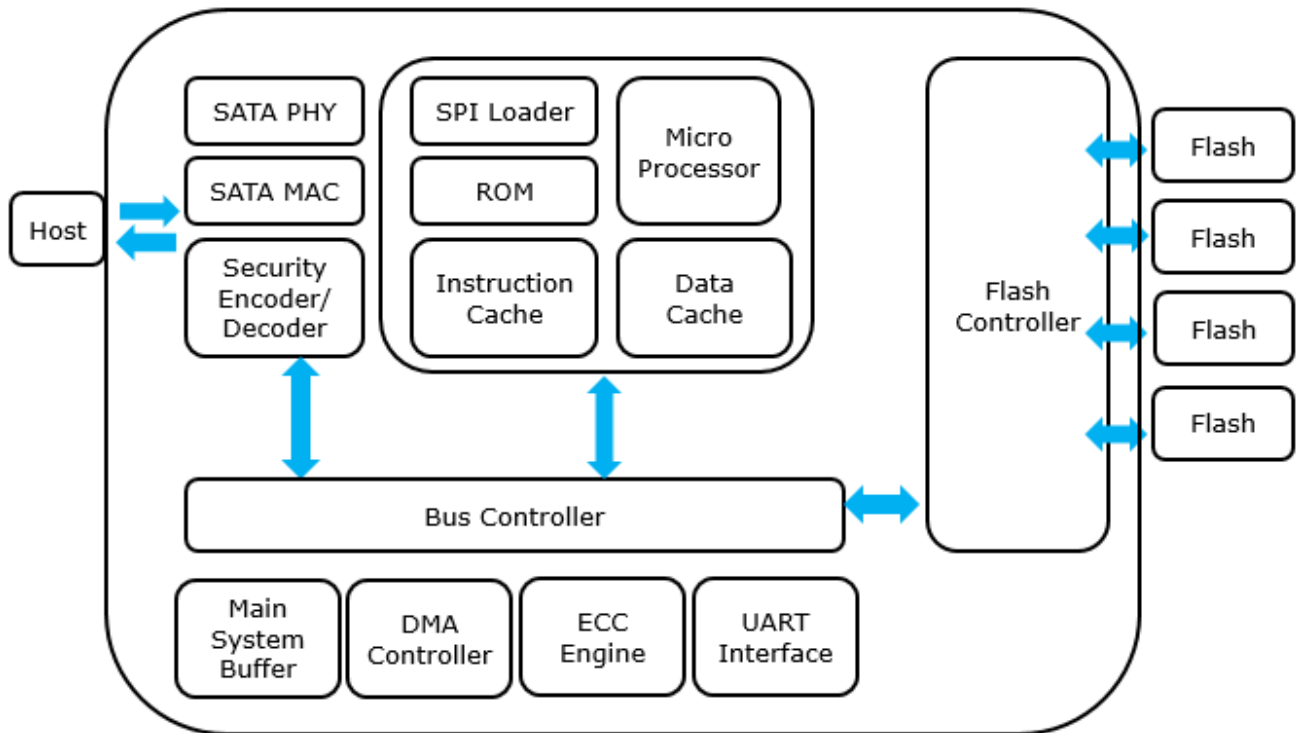

**Figure 2: Innodisk M.2 (S42) 3ME2 Block Diagram**

Innodisk M.2 (S42) 3ME2 integrates a SATA III controller and NAND flash memories. Communication with the host occurs through the host interface, using the standard ATA protocol. Communication with the flash device(s) occurs through the flash interface.

## 3.2 SATA III Controller

Innodisk M.2 (S42) 3ME2 is designed with ID 202, a SATA III 6.0Gbps (Gen. 3) controller. The Serial ATA physical, link and transport layers are compliant with Serial ATA Gen 1, Gen 2 and Gen 3 specification (Gen 3 supports 1.5Gbps/3.0Gbps/6.0Gbps data rate). The controller has 2 channels for flash interface.

### 3.3 Error Detection and Correction

Highly sophisticated Error Correction Code algorithms are implemented. The ECC unit consists of the Parity Unit (parity-byte generation) and the Syndrome Unit (syndrome-byte computation). This unit implements an algorithm that can correct 66 bits per 1024 bytes in an ECC block. Code-byte generation during write operations, as well as error detection during read operation, is implemented on the fly without any speed penalties.

### 3.4 Wear-Leveling

Flash memory can be erased within a limited number of times. This number is called the **erase cycle limit** or **write endurance limit** and is defined by the flash array vendor. The erase cycle limit applies to each individual erase block in the flash device.

Innodisk M.2 (S42) 3ME2 uses a static wear-leveling algorithm to ensure that consecutive writes of a specific sector are not written physically to the same page/block in the flash. This spreads flash media usage evenly across all pages, thereby extending flash lifetime.

### 3.5 Bad Blocks Management

Bad Blocks are blocks that contain one or more invalid bits whose reliability are not guaranteed. The Bad Blocks may be presented while the SSD is shipped, or may develop during the life time of the SSD. When the Bad Blocks is detected, it will be flagged, and not be used anymore. The SSD implement Bad Blocks management, Bad Blocks replacement, Error Correct Code to avoid data error occurred. The functions will be enabled automatically to transfer data from Bad Blocks to spare blocks, and correct error bit.

### 3.6 Power Cycling

Innodisk's power cycling management is a comprehensive data protection mechanism that functions before and after a sudden power outage to SSD. Low-power detection terminates data writing before an abnormal power-off, while table-remapping after power-on deletes corrupt data and maintains data integrity. Innodisk's power cycling provides effective power cycling management, preventing data stored in flash from degrading with use.

### 3.7 Garbage Collection

Garbage collection is used to maintain data consistency and perform continual data cleansing on SSDs. It runs as a background process, freeing up valuable controller resources while sorting good

data into available blocks, and deleting bad blocks. It also significantly reduces write operations to the drive, thereby increasing the SSD's speed and lifespan.

## 4. Installation Requirements

### 4.1 M.2 (S42) 3ME2 Pin Directions

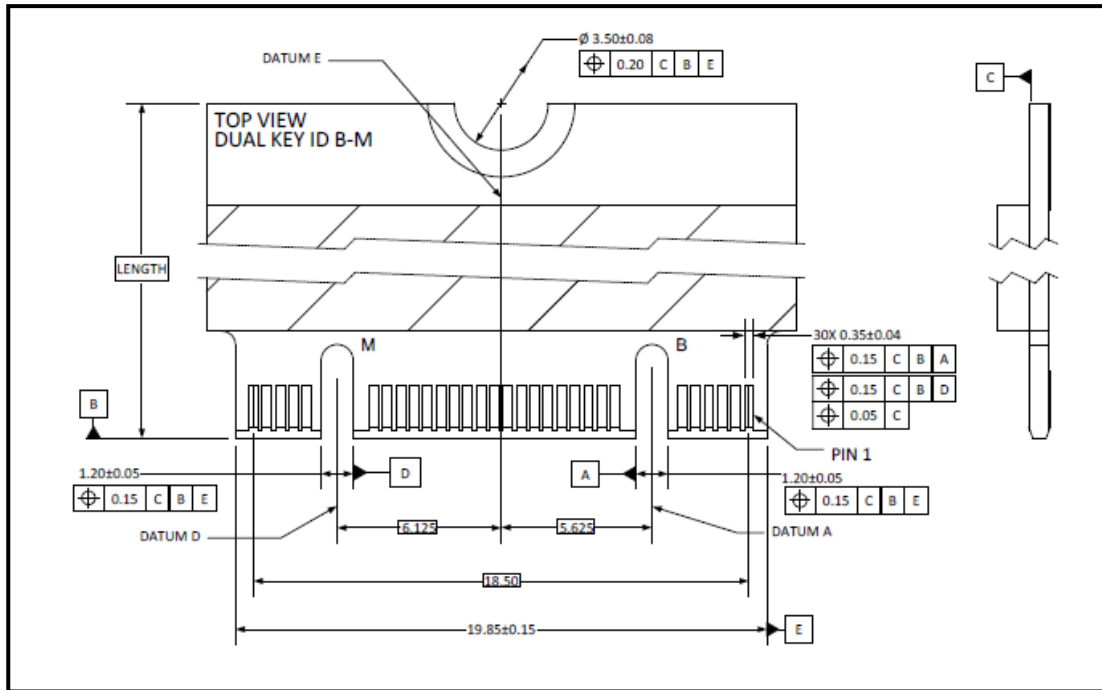

**Figure 3: Signal Segment and Power Segment**

### 4.2 Electrical Connections for M.2 (S42) 3ME2

A Serial ATA device may be either directly connected to a host or connected to a host through a cable. For connection via cable, the cable should be no longer than 1meter. The SATA interface has a separate connector for the power supply. Please refer to the pin description for further details.

### 4.3 Device Drive

No additional device drives are required. The Innodisk M.2 (S42) 3ME2 can be configured as a boot device.



## 5. Part Number Rule

CODE	1	2	3	4	5	6	7	8	9	10	11	12	13	14	15	16	17	18	19	20	21
	<b>D</b>	<b>E</b>	<b>M</b>	<b>2</b>	<b>4</b>	<b>-</b>	<b>3</b>	<b>2</b>	<b>G</b>	<b>D</b>	<b>7</b>	<b>2</b>	<b>S</b>	<b>C</b>	<b>A</b>	<b>D</b>	<b>N</b>	<b>-</b>	<b>X</b>	<b>X</b>	<b>X</b>
<b>Definition</b>																					
<b>Code 1<sup>st</sup> (Disk)</b>											<b>Code 14<sup>th</sup> (Operation Temperature)</b>										
D : Disk											C: Standard Grade (0°C ~ +70°C)										
<b>Code 2<sup>nd</sup> (Feature set)</b>											W: Industrial Grade (-40°C ~ +85°C)										
E : Embedded series											<b>Code 15<sup>th</sup> (Internal control)</b>										
<b>Code 3<sup>rd</sup> ~5<sup>th</sup> (Form factor)</b>											A~Z: BGA PCB version.										
M24: M.2-SATA Type 2242											<b>Code 16<sup>th</sup> (Channel of data transfer)</b>										
<b>Code 7<sup>th</sup> ~9<sup>th</sup> (Capacity)</b>											S: Single Channel										
16G: 16GB. 32G: 32GB 64G: 64GB A28: 128GB B56: 256GB											D: Dual Channels										
											Q: Quad Channels										
<b>Code 10<sup>th</sup> ~12<sup>th</sup> (Controller)</b>											<b>Code 17<sup>th</sup> (Flash Type)</b>										
D72: ID202											N: Micron MLC										
											C: Toshiba MLC										
<b>Code 13<sup>th</sup> (Flash mode)</b>											<b>Code 19<sup>th</sup>~21<sup>st</sup> (Customize code)</b>										
S: Synchronous NAND.																					

# Appendix



## 宜鼎國際股份有限公司 Innodisk Corporation

Tel:(02)7703-3000 Fax:(02) 7703-3555 Internet: <http://www.innodisk.com/>

### RoHS 自我宣告書 (RoHS Declaration of Conformity)

#### Manufacturer Product: All Innodisk EM Flash and Dram products

- 一、 宜鼎國際股份有限公司（以下稱本公司）特此保證售予貴公司之所有產品，皆符合歐盟 2011/65/EU 關於 RoHS 之規範要求。

Innodisk Corporation declares that all products sold to the company, are complied with European Union RoHS Directive (2011/65/EU) requirement

- 二、 本公司同意因本保證書或與本保證書相關事宜有所爭議時，雙方宜友好協商，達成協議。

Innodisk Corporation agrees that both parties shall settle any dispute arising from or in connection with this Declaration of Conformity by friendly negotiations.

Name of hazardous substance	Limited of RoHS ppm (mg/kg)
Cd	< 100 ppm
Pb	< 1000 ppm
Hg	< 1000 ppm
Chromium VI (Cr+6)	< 1000 ppm
Polybromodiphenyl ether (PBDE)	< 1000 ppm
Polybrominated Biphenyls (PBB)	< 1000 ppm

#### 立保證書人 (Guarantor)

Company name 公司名稱： Innodisk Corporation 宜鼎國際股份有限公司

Company Representative 公司代表人： Richard Lee 李鐘亮

Company Representative Title 公司代表人職稱： CEO 執行長

Date 日期： 2014 / 07 / 29



innodisk

## 宜鼎國際股份有限公司 Innodisk Corporation

Tel:(02)7703-3000 Fax:(02) 7703-3555 Internet: <http://www.innodisk.com/>

### REACH Declaration of Conformity

#### Manufacturer Product: All Innodisk EM Flash and Dram products

1.宜鼎國際股份有限公司（以下稱本公司）特此保證此售予貴公司之產品，皆符合歐盟化學品法案(Registration, Evaluation and Authorization of Chemicals; REACH)之規定

(<http://www.echa.europa.eu/de/candidate-list-table> last updated: 16/05/2014)。所提供之產品包含：(1) 產品或產品所使用到的所有原物料；(2)包裝材料；(3)設計、生產及重工過程中所使用到的所有原物料。

We Innodisk Corporation hereby declare that our products are in compliance with the requirements according to the REACH Regulation

(<http://www.echa.europa.eu/de/candidate-list-table> last updated: 16/06/2014).

Products include: 1) Product and raw material used by the product; 2) Packaging material; 3) Raw material used in the process of design, production and rework

2.本公司同意因本保證書或與本保證書相關事宜有所爭議時，雙方宜友好協商，達成協議。

InnoDisk Corporation agrees that both parties shall settle any dispute arising from or in connection with this Declaration of Conformity by friendly negotiations.

#### 立保證書人 (Guarantor)

Company name 公司名稱：InnoDisk Corporation 宜鼎國際股份有限公司

Company Representative 公司代表人：Richard Lee 李鐘亮

Company Representative Title 公司代表人職稱：CEO 執行長

Date 日期：2014 / 07 / 29

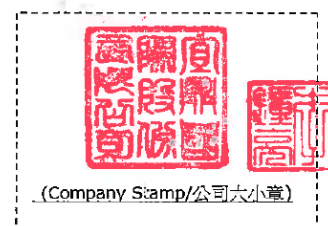

# Certificate

Issue Date: July 29, 2015  
Ref. Report No. ISL-15LE321CE

Product Name : M.2  
Model(s) : M.2 (S42) 3S\*#-&  
(S:Flash type: (S:SLC, I:iSLC, M:MLC);  
\*:Product line: (E:Embedded, G:EverGreen, R:InnoRobust);  
#:Controller: (empty:106/107/167/170, 2:201/ 202, 3:108/109);  
&:Product feature: (P:with DRAM, empty:without DRAM))  
Responsible Party : Innodisk Corporation  
Address : 5F No.237, Sec. 1, Datong Rd., Xizhi Dist., New Taipei City 221, Taiwan  
(R.O.C.)

We, International Standards Laboratory, hereby certify that:

The device bearing the trade name and model specified above has been shown to comply with the applicable technical standards as indicated in the measurement report and was tested in accordance with the measurement procedures specified in European Council Directive- EMC Directive 2004/108/EC. The device was passed the test performed according to :



**Standards:**

EN 55022: 2010+AC2011 and CISPR 22: 2008 (modified)  
EN 61000-3-2: 2006+A1:2009 +A2:2009 and IEC 61000-3-2: 2005+A1:2008 +A2:2009  
EN 61000-3-3: 2013 and IEC 61000-3-3: 2013  
EN 55024: 2010 and CISPR 24: 2010  
EN 61000-4-2: 2009 and IEC 61000-4-2: 2008  
EN 61000-4-3: 2006+A1: 2008 +A2: 2010 and  
IEC 61000-4-3:2006+A1: 2007+A2: 2010  
EN 61000-4-4:2012 and IEC 61000-4-4:2012

I attest to the accuracy of data and all measurements reported herein were performed by me or were made under my supervision and are correct to the best of my knowledge and belief. I assume full responsibility for the completeness of these measurements and vouch for the qualifications of all persons taking them.

International Standards Laboratory

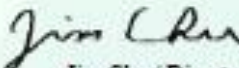
  
Jim Chu / Director

Hsi-Chih LAB:

No. 65, Gu Dai Keng Street, Hsi-Chih Dist.,  
New Taipei City 221, Taiwan  
Tel: 886-2-2646-2550; Fax: 886-2-2646-4641



Lung-Tan LAB:

No. 120, Lane 180, Hsin Ho Rd., Lung-Tan Dist.,  
Tao Yuan City 325, Taiwan  
Tel: 886-3-407-1718; Fax: 886-3-407-1738



# Certificate

Issue Date: July 29, 2015  
Ref. Report No. ISL-15LE321FB

Product Name : M.2  
Model(s) : M.2 (S42) 35\*#-&  
(S:Flash type: (S:SLC,I:SLC,M:MLC);  
\*:Product line: (E:Embedded, G:EverGreen, R:InnoRobust);  
#:Controller: ( empty:106/107/167/170, 2:201/202, 3:108/109);  
&:Product feature: (P:with DRAM, empty:without DRAM))  
Applicant : Innodisk Corporation  
Address : 5F.No.237, Sec. 1, Datong Rd., Xizhi Dist., New Taipei City 221, Taiwan  
(R.O.C.)

We, **International Standards Laboratory**, hereby certify that:

The device bearing the trade name and model specified above has been shown to comply with the applicable technical standards as indicated in the measurement report and was tested in accordance with the measurement procedures specified. (refer to Test Report if any modifications were made for compliance).



Standards:

FCC CFR Title 47 Part 15 Subpart B: 2014- Section 15.107 and 15.109  
ANSI C63.4-2009  
Industry Canada Interference-Causing Equipment Standard ICES-003 Issue 5: 2012

Class B

I attest to the accuracy of data and all measurements reported herein were performed by me or were made under my supervision and are correct to the best of my knowledge and belief. I assume full responsibility for the completeness of these measurements and vouch for the qualifications of all persons taking them.

International Standards Laboratory

  
Jim Chu / Director

Hsi-Chih LAB:  
No. 65, Gu Dai Keng Street, Hsi-Chih Dist.,  
New Taipei City 221, Taiwan  
Tel: 886-2-2646-2550; Fax: 886-2-2646-4641



Lung-Tan LAB:  
No. 120, Lane 180, Hsin Ho Rd., Lung-Tan Dist.,  
Tao Yuan City 325, Taiwan  
Tel: 886-3-407-1718; Fax: 886-3-407-1738

