

1.8" SATA SSD

3MR3-P Series

Customer: _____

Customer

Part

Number: _____

Innodisk

Part

Number: _____

Innodisk

Model Name: _____

Date: _____

Innodisk Approver	Customer Approver

**Total Solution For
Industrial Flash Storage**

Table of Contents

- LIST OF FIGURES6**
- 1. PRODUCT OVERVIEW7**
 - 1.1 INTRODUCTION OF INNODISK 1.8" SATA SSD 3MR3-P.....7**
 - 1.2 PRODUCT VIEW AND MODELS7**
 - 1.3 SATA INTERFACE.....7**
- 2. PRODUCT SPECIFICATIONS9**
 - 2.1 CAPACITY AND DEVICE PARAMETERS.....9**
 - 2.2 PERFORMANCE9**
 - 2.3 ELECTRICAL SPECIFICATIONS9**
 - 2.3.1 Power Requirement.....9**
 - 2.3.2 Power Consumption10**
 - 2.4 ENVIRONMENTAL SPECIFICATIONS10**
 - 2.4.1 Temperature Ranges10**
 - 2.4.2 Humidity.....10**
 - 2.4.3 Shock and Vibration10**
 - 2.4.4 Mean Time between Failures (MTBF)10**
 - 2.5 CE AND FCC COMPATIBILITY11**
 - 2.6 RoHS COMPLIANCE11**
 - 2.7 RELIABILITY11**
 - * TOTAL BYTES WRITTEN IS BASED ON JEDEC 218 (SOLID-STATE DRIVE11**
REQUIREMENTS AND ENDURANCE TEST METHOD)11
 - 2.8 TRANSFER MODE11**
 - 2.9 PIN ASSIGNMENT11**
 - 2.10 MECHANICAL DIMENSIONS.....12**
 - 2.11 ASSEMBLY WEIGHT13**
 - 2.12 SEEK TIME13**
 - 2.13 HOT PLUG.....13**
 - 2.14 NAND FLASH MEMORY.....13**
- 3. THEORY OF OPERATION14**
 - 3.1 OVERVIEW.....14**
 - 3.2 SATA III CONTROLLER14**
 - 3.3 ERROR DETECTION AND CORRECTION.....15**
 - 3.4 WEAR-LEVELING15**
 - 3.5 BAD BLOCKS MANAGEMENT15**
 - 3.6 POWER CYCLING15**
 - 3.7 GARBAGE COLLECTION/TRIM15**
 - 3.8 QUICK ERASE.....16**

- 3.9 SECURE ERASE..... 17**
 - 1. *AFFSI5020* 18
 - 2. *DoD 5220.22-M*..... 19
 - 3. *USA Navy NAVSO P-5239-26* 20
 - 4. *NSA Manual 130-2*..... 21
 - 5. *USA-Army 380-19*..... 23
 - 6. *NISPOMSUP Chap 8, Sect. 8-501* 24
 - 7. *NSA Manual 9-12* 25
 - 8. *IRIG1006*..... 26
- 3.10 DESTROY (UNRECOVERABLE DESTROY) 27**
- 4. INSTALLATION REQUIREMENTS 29**
 - 4.1 1.8" SATA SSD 3MR3-P PIN DIRECTIONS..... 29**
 - 4.2 ELECTRICAL CONNECTIONS FOR 1.8" SATA SSD 3MR3-P 29**
 - 4.3 DEVICE DRIVE 29**
- 5. PART NUMBER RULE 30**

REVISION HISTORY

Revision	Description	Date
Rev. 1.0	First Released	March, 2016

List of Tables

TABLE 1: DEVICE PARAMETERS.....9

TABLE 2: PERFORMANCE9

TABLE 3: INNODISK 1.8" SATA SSD 3MR3-P POWER REQUIREMENT.....9

TABLE 4: POWER CONSUMPTION10

TABLE 5: TEMPERATURE RANGE FOR 1.8" SATA SSD 3MR3-P10

TABLE 6: SHOCK/VIBRATION TESTING FOR 1.8" SATA SSD 3MR3-P10

TABLE 7: 1.8" SATA SSD 3MR3-P MTBF.....11

TABLE 8: INNODISK 1.8" SATA SSD 3MR3-P PIN ASSIGNMENT.....11

List of Figures

FIGURE 1: INNODISK 1.8" SATA SSD 3MR3-P	7
FIGURE 2: INNODISK 1.8" SATA SSD 3MR3-P BLOCK DIAGRAM.....	14
FIGURE 3: SIGNAL SEGMENT AND POWER SEGMENT	29

1. Product Overview

1.1 Introduction of Innodisk 1.8" SATA SSD 3MR3-P

Innodisk 1.8" SATA SSD 3MR3-P products provide high capacity flash memory Solid State Drive (SSD) that electrically complies with Serial ATA (SATA) standard. It supports SATA III standard (6.0GHz) with high performance. Innodisk 1.8" SATA SSD 3MR3-P is designed for industrial field, and supports several standard features, including NCQ, and S.M.A.R.T. The SSD has good performance with no latency time and small seek time. It effectively reduces the booting time of operation system and the power consumption is less than hard disk drive (HDD).

1.2 Product View and Models

Innodisk 1.8" SATA SSD 3MR3-P is available in follow capacities within MLC flash ICs.

1.8" SATA SSD 3MR3-P 8GB 1.8" SATA SSD 3MR3-P 128GB

1.8" SATA SSD 3MR3-P 16GB 1.8" SATA SSD 3MR3-P 256GB

1.8" SATA SSD 3MR3-P 32GB 1.8" SATA SSD 3MR3-P 512GB

1.8" SATA SSD 3MR3-P 64GB



Figure 1: Innodisk 1.8" SATA SSD 3MR3-P

1.3 SATA Interface

Innodisk 1.8" SATA SSD 3MR3-P supports SATA III interface, and compliant with SATA I and SATA II. SATA III interface can work with Serial Attached SCSI (SAS) host system, which is used in server computer. Innodisk 1.8" SATA SSD 3MR3-P is compliant with Serial ATA Gen 1, Gen 2 and Gen 3 specification (Gen 3 supports 1.5Gbps /3.0Gbps/6.0Gbps data rate). SATA connector uses a 7-pin signal segment and a 9-pin power segment.

1.4 1.8-inch Form Factor

The Industry-standard 1.8-inch form factor is designed with metal material case, which is easy for installation because 1.8-inch is a commonly used form factor in industrial field. Innodisk 1.8" SATA SSD 3MR3-P has a compact design 54.0mm (W) x78.5mm (L) x 5.0mm (H).

2. Product Specifications

2.1 Capacity and Device Parameters

1.8" SATA SSD 3MR3-P device parameters are shown in Table 1.

Table 1: Device parameters

Capacity	LBA	Cylinders	Heads	Sectors	User Capacity(MB)
8GB	13695696	16383	16	63	6687
16GB	29323728	16383	16	63	14318
32GB	60579792	16383	16	63	29580
64GB	121138416	16383	16	63	59150
128GB	242256664	16383	16	63	118289
256GB	484490160	16383	16	63	236567
512GB	968959152	16383	16	63	473125

2.2 Performance

Burst Transfer Rate: 6.0Gbps

Table 2: Performance

Capacity	8GB	16GB	32GB	64GB	128GB	256GB	512GB
Sequential Read* (max.) MB/sec	120	120	230	350	440	480	480
Sequential Write* (max.) MB/sec	25	20	40	80	150	220	220
4KB Random** Read (QD32)	8,800 IOPS	8,600 IOPS	15,200 IOPS	25,000 IOPS	31,700 IOPS	30,000 IOPS	30,000 IOPS
4KB Random** Write (QD32)	6,000 IOPS	5,500 IOPS	8,800 IOPS	14,400 IOPS	24,400 IOPS	32,000 IOPS	32,500 IOPS

Note: * Sequential performance based on CrystalDiskMark 3.03 with file size 100MB

** Random performance based on Iometer with Queue Depth 32

2.3 Electrical Specifications

2.3.1 Power Requirement

Table 3: Innodisk 1.8" SATA SSD 3MR3-P Power Requirement

Item	Symbol	Rating	Unit
Input voltage	V _{IN}	+5 DC +- 5%	V

2.3.2 Power Consumption

Table 4: Power Consumption

Mode	Power Consumption (mA)
Read	630 mA (max.)
Write	1.2 A (max.)
Idle	77 mA (max.)

* Target: 1.8" SATA SSD 3MR3-P 256GB

2.4 Environmental Specifications

2.4.1 Temperature Ranges

Table 5: Temperature range for 1.8" SATA SSD 3MR3-P

Temperature	Range
Operating	Standard Grade: 0°C to +70°C
	Industrial Grade: -40°C to +85°C
Storage	-55°C to +95°C

2.4.2 Humidity

Relative Humidity: 10-95%, non-condensing

2.4.3 Shock and Vibration

Table 6: Shock/Vibration Testing for 1.8" SATA SSD 3MR3-P

Reliability	Test Conditions	Reference Standards
Vibration	7 Hz to 2K Hz, 20G, 3 axes	IEC 68-2-6
Mechanical Shock	Duration: 0.5ms, 1500 G, 3 axes	IEC 68-2-27

2.4.4 Mean Time between Failures (MTBF)

Table 7 summarizes the MTBF prediction results for various 1.8" SATA SSD 3MR3-P configurations. The analysis was performed using a RAM Commander™ failure rate prediction.

- **Failure Rate:** The total number of failures within an item population, divided by the total number of life units expended by that population, during a particular measurement interval under stated condition.
- **Mean Time between Failures (MTBF):** A basic measure of reliability for repairable items: The mean number of life units during which all parts of the item perform within their specified limits, during a particular measurement interval under stated conditions.

Table 7: 1.8" SATA SSD 3MR3-P MTBF

Product	Condition	MTBF (Hours)
Innodisk 1.8" SATA SSD 3MR3-P	Telcordia SR-332 GB, 25°C	>3,000,000

2.5 CE and FCC Compatibility

1.8" SATA SSD 3MR3-P conforms to CE and FCC requirements.

2.6 RoHS Compliance

1.8" SATA SSD 3MR3-P is fully compliant with RoHS directive.

2.7 Reliability

Parameter	Value
Read Cycles	Unlimited Read Cycles
Wear-Leveling Algorithm	Support
Bad Blocks Management	Support
Error Correct Code	Support
TBW (Unit: TB)	
8GB	2.3
16GB	4.7
32GB	9.4
64GB	18.8
128GB	37.5
256GB	75.2
512GB	150.4
* Total bytes written is based on JEDEC 218 (Solid-State Drive Requirements and Endurance Test Method)	
** Lifespan is calculated by device written per day	

2.8 Transfer Mode

1.8" SATA SSD 3MR3-P support the following transfer modes,

Serial ATA III 6.0Gbps

Serial ATA II 3.0Gbps

Serial ATA I 1.5Gbps

2.9 Pin Assignment

Innodisk 1.8" SATA SSD 3MR3-P uses a standard SATA pin-out. See Table 8 for 1.8" SATA SSD 3MR3-P pin assignment.

Table 8: Innodisk 1.8" SATA SSD 3MR3-P Pin Assignment

Name	Type	Description
S1	GND	NA
S2	A+	Differential Signal Pair A

S3	A-	
S4	GND	NA
S5	B-	Differential Signal Pair B
S6	B+	
S7	GND	NA
Key and Spacing separate signal and power segments		
P1	V33	3.3V Power
P2	V33	3.3V Power, Pre-charge
P3	GND	NA
P4	GND	NA
P5	V5	5V Power, Pre-charge
P6	V5	5V Power
P7	R	Reserved
Key	Key	Key
P8	Optional	Write Protect
P9	Optional	Quick Erase

2.10 Mechanical Dimensions

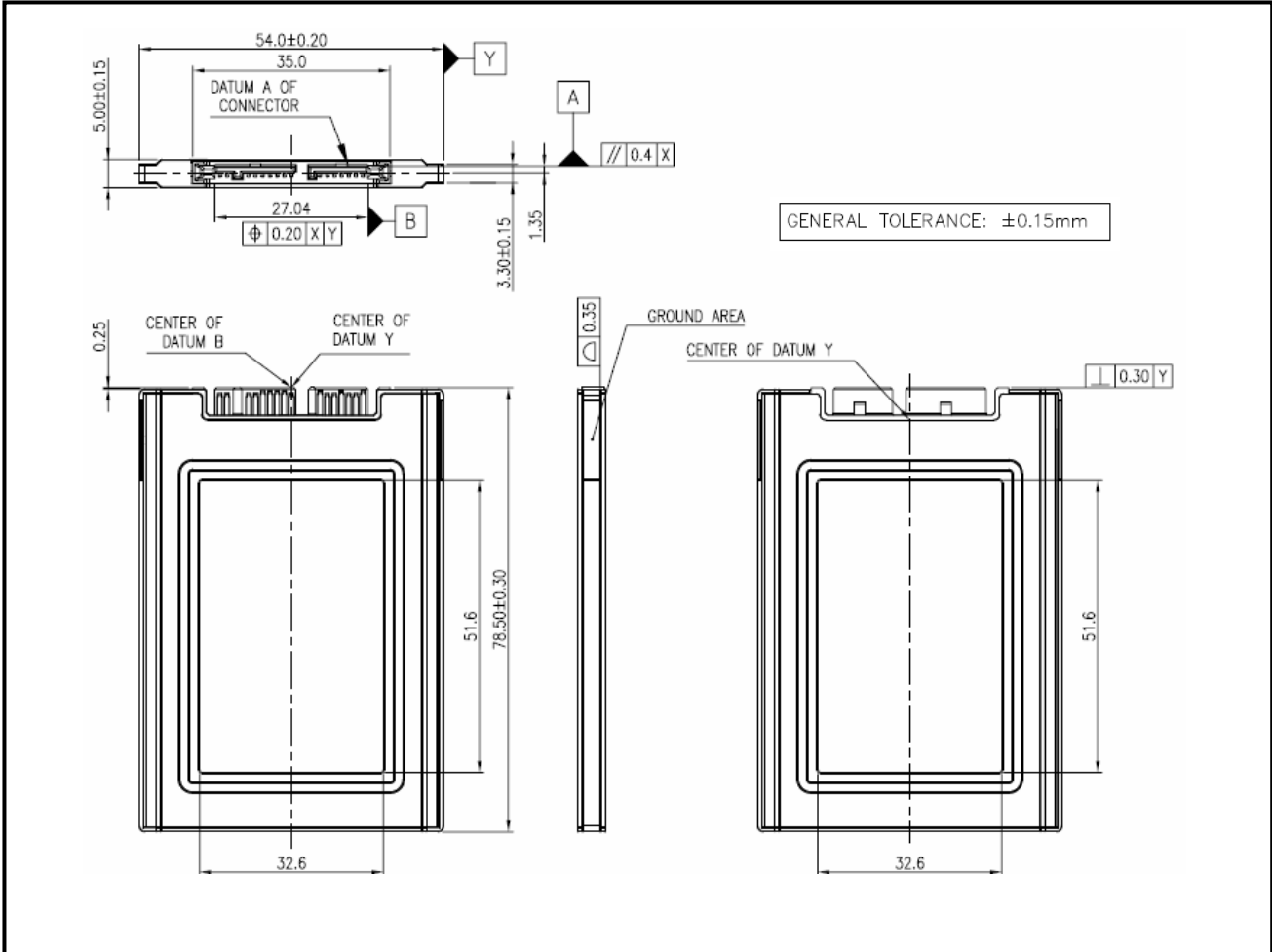

2.11 Assembly Weight

An Innodisk 1.8" SATA SSD 3MR3-P within MLC flash ICs, 32GB's weight is 55 grams approx. The total weight of SSD will be less than 60 grams.

2.12 Seek Time

Innodisk 1.8" SATA SSD 3MR3-P is not a magnetic rotating design. There is no seek or rotational latency required.

2.13 Hot Plug

The SSD support hot plug function and can be removed or plugged-in during operation. User has to avoid hot plugging the SSD which is configured as boot device and installed operation system.

Surprise hot plug : The insertion of a SATA device into a backplane (combine signal and power) that has power present. The device powers up and initiates an OOB sequence.

Surprise hot removal: The removal of a SATA device from a powered backplane, without first being placed in a quiescent state.

2.14 NAND Flash Memory

Innodisk 1.8" SATA SSD 3MR3-P uses Multi Level Cell (MLC) NAND flash memory, which is non-volatility, high reliability and high speed memory storage.

3. Theory of Operation

3.1 Overview

Figure 2 shows the operation of Innodisk 1.8" SATA SSD 3MR3-P from the system level, including the major hardware blocks.

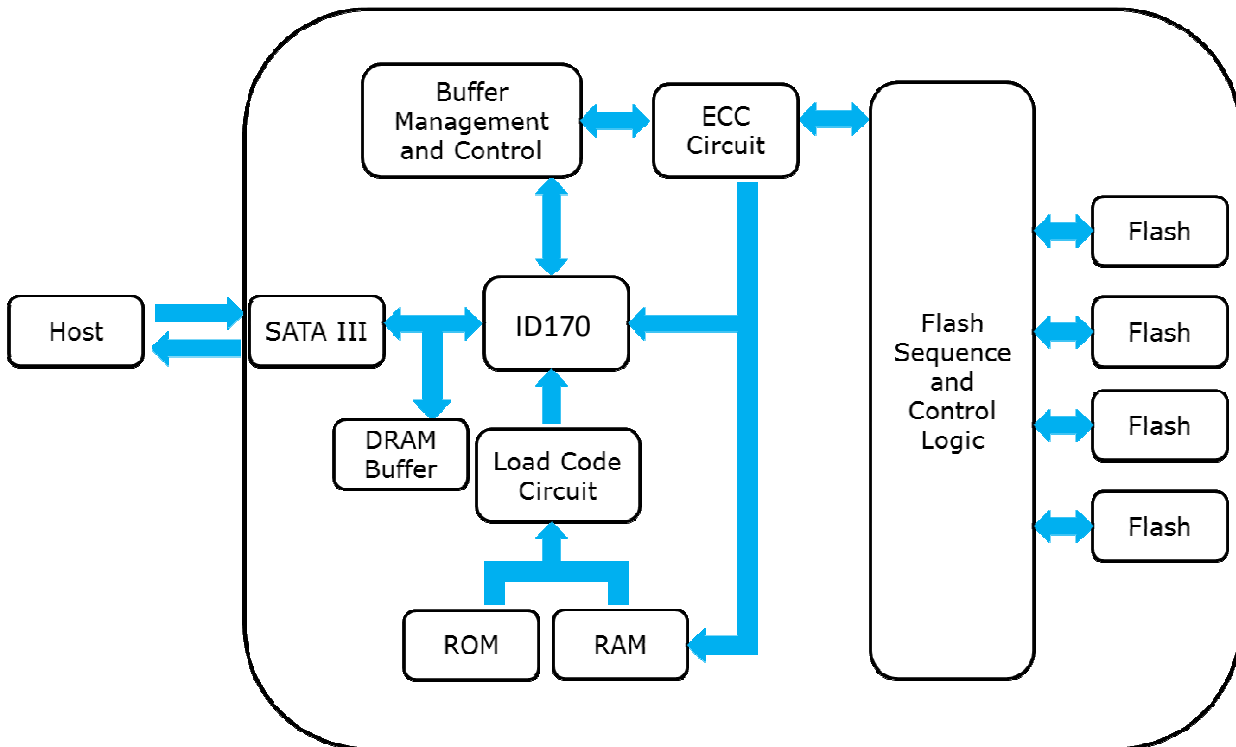

Figure 2: Innodisk 1.8" SATA SSD 3MR3-P Block Diagram

Innodisk 1.8" SATA SSD 3MR3-P integrates a SATA III controller and NAND flash memories. Communication with the host occurs through the host interface, using the standard ATA protocol. Communication with the flash device(s) occurs through the flash interface.

3.2 SATA III Controller

Innodisk 1.8" SATA SSD 3MR3-P is designed with ID 167, a SATA III 6.0Gbps (Gen. 3) controller, which supports external DDR3 DRAM. The Serial ATA physical, link and transport layers are compliant with Serial ATA Gen 1, Gen 2 and Gen 3 specification (Gen 3 supports 1.5Gbps/3.0Gbps/6.0Gbps data rate). The controller has 4 channels for flash interface.

3.3 Error Detection and Correction

Highly sophisticated Error Correction Code algorithms are implemented. The ECC unit consists of the Parity Unit (parity-byte generation) and the Syndrome Unit (syndrome-byte computation). This unit implements an algorithm that can correct 66 bits per 1024 bytes in an ECC block. Code-byte generation during write operations, as well as error detection during read operation, is implemented on the fly without any speed penalties.

3.4 Wear-Leveling

Flash memory can be erased within a limited number of times. This number is called the **erase cycle limit** or **write endurance limit** and is defined by the flash array vendor. The erase cycle limit applies to each individual erase block in the flash device.

Innodisk 1.8" SATA SSD 3MR3-P uses a static wear-leveling algorithm to ensure that consecutive writes of a specific sector are not written physically to the same page/block in the flash. This spreads flash media usage evenly across all pages, thereby extending flash lifetime.

3.5 Bad Blocks Management

Bad Blocks are blocks that contain one or more invalid bits whose reliability are not guaranteed. The Bad Blocks may be presented while the SSD is shipped, or may develop during the life time of the SSD. When the Bad Blocks is detected, it will be flagged, and not be used anymore. The SSD implement Bad Blocks management, Bad Blocks replacement, Error Correct Code to avoid data error occurred. The functions will be enabled automatically to transfer data from Bad Blocks to spare blocks, and correct error bit.

3.6 Power Cycling

Innodisk's power cycling management is a comprehensive data protection mechanism that functions before and after a sudden power outage to SSD. Low-power detection terminates data writing before an abnormal power-off, while table-remapping after power-on deletes corrupt data and maintains data integrity. Innodisk's power cycling provides effective power cycling management, preventing data stored in flash from degrading with use.

3.7 Garbage Collection/TRIM

Garbage collection and TRIM technology is used to maintain data consistency and perform continual data cleansing on SSDs. It runs as a background process, freeing up valuable controller resources while sorting good data into available blocks, and deleting bad blocks. It also significantly reduces write operations to the drive, thereby increasing the SSD's speed and lifespan.

3.8 Quick Erase

Quick Erase function is designed for emergency data erase in few seconds by providing ATA command.

3.8.1 Quick Erase Command

-Protocol: Non Data Command

-Inputs

Table 9: Execute Quick Erase command for inputs information

Register	7	6	5	4	3	2	1	0
Features	21h							
Sector Count	41h							
LBA Low	Na							
LBA Mid	Na							
LBA High	Na							
Device	1	1	1	0	Na			
Command	82h							

-Normal Outputs

Table 10: Quick Erase command for normal output information

Register	7	6	5	4	3	2	1	0
Error	Na							
Sector Count	Na							
LBA Low	Na							
LBA Mid	Na							
LBA High	Na							
Device	obs	Na	obs	DEV	Na	Na	Na	Na
Status	BSY	DRDY	DF	Na	DRQ	Na	Na	ERR

Device register-

DEV shall specify the selected device.

Status register

BSY will be cleared to zero indicating command completion

DRDY will be set to one.

DF (Device Fault) will be cleared to zero.

DRQ will be cleared to zero

ERR will be cleared to zero.

3.9 Secure Erase

Secure Erase function is designed for emergency data erase to comply with military standard. Erase functions can be triggered sending ATA Command. All Data Block of flash chip will be erased by sending flash erase command.

Innodisk provides the following Security Erase for options:

- (1) AFFSI 5020
- (2) DoD 5220.22-M
- (3) USA Navy NAVSO P-5239-26
- (4) NSA Manual 130-2
- (5) USA-Army 380-19
- (6) NISPOMSUP Chap 8, Sect. 8-501
- (7) NSA Manual 9-12
- (8) IRIG 106

3.9.1 Secure Erase Command

Identify Information

Word 159 of Identify Table shows the SE pin's function. Identify Table can be read by sending ECh ATA command.

Table 11: Identify Information

	Secure Function Support		
	7-15	Reserved	0
	6	1= Secure Erase ATA Vendor Command Supported	X
	5	Reserved	0
154	4	1=Quick Erase ATA Vendor Command Supported	X
	3	1=Destroy ATA Vendor Command Supported	X
	1	1=Jumper Secure Erase Supported	X
	1	1=Jumper Write Protect Supported	X
	0	1=Jumper Quick Erase Supported	X
155	Secure Function Status(Enable/Disable)		

	2-15 Reserved	
	1 1= Write Protect Enabled	X
	0 Reserved	0
156-158	Vendor Specific	
159	8~15 Function of Jumper "QE" 0x20: Destroy 0x21 or Others: Quick Erase 0~7 Secure Erase Function of Jumper "SE" 0x22: AFFSI 5020 0x23: DoD 5220.22-M 0x24: USA Navy NAVSO P-5239-26 0x25: NSA Manual 130-2 0x26: USA-Army 380-19 0x27: NISPOMSUP Chap 8, Sect. 8-501 0x28: NSA Manual 9-12 0x29: IRIG106	XXXXh

1. AFFSI5020

This function is compliant with AFFSI 5020 specification.

Steps:

1. The whole disk is erased using Flash Erase Command.
2. The whole disk is filled with random data.

-Protocol: Non Data Command

-Inputs

Table 12: Execute AFFSI 5020 command for inputs information

Register	7	6	5	4	3	2	1	0
Features	22h							

Sector Count	41h				
LBA Low	Na				
LBA Mid	Na				
LBA High	Na				
Device	1	1	1	0	Na
Command	82h				

-Normal Outputs

Table 13: AFFSI 5020 command for normal output information

Register	7	6	5	4	3	2	1	0
Error	Na							
Sector Count	Na							
LBA Low	Na							
LBA Mid	Na							
LBA High	Na							
Device	obs	Na	obs	DEV	Na	Na	Na	Na
Status	BSY	DRDY	DF	Na	DRQ	Na	Na	ERR

Device register-

DEV shall specify the selected device.

Status register

BSY will be cleared to zero indicating command completion

DRDY will be set to one.

DF (Device Fault) will be cleared to zero.

DRQ will be cleared to zero

ERR will be cleared to zero.

2. DoD 5220.22-M

This function is compliant with DoD 5220.22-M specification.

Steps:

1. The whole disk is filled with fixed character pattern 0x55.
2. The whole disk is erased using Flash Erase Command.

-Protocol: Non Data Command

-Inputs

Table 14: Execute DoD 5220.22-M command for inputs information

Register	7	6	5	4	3	2	1	0
Features	23h							
Sector Count	41h							
LBA Low	Na							
LBA Mid	Na							
LBA High	Na							
Device	1	1	1	0	Na			
Command	82h							

-Normal Outputs

Table 15: DoD 5220.22-M command for normal output information

Register	7	6	5	4	3	2	1	0
Error	Na							
Sector Count	Na							
LBA Low	Na							
LBA Mid	Na							
LBA High	Na							
Device	obs	Na	obs	DEV	Na	Na	Na	Na
Status	BSY	DRDY	DF	Na	DRQ	Na	Na	ERR

Device register-

DEV shall specify the selected device.

Status register

BSY will be cleared to zero indicating command completion

DRDY will be set to one.

DF (Device Fault) will be cleared to zero.

DRQ will be cleared to zero

ERR will be cleared to zero.

3. USA Navy NAVSO P-5239-26

This function is compliant with USA Navy NAVSO P-5239-26 specification.

Steps:

1. The whole disk is erased using Flash Erase Command.
2. The whole disk is filled with random data.
3. The whole disk is erased using Flash Erase Command.

-Protocol: Non Data Command**-Inputs****Table 16: Execute USA Navy NAVSO P-5239-26 command for inputs information**

Register	7	6	5	4	3	2	1	0
Features	24h							
Sector Count	41h							
LBA Low	Na							
LBA Mid	Na							
LBA High	Na							
Device	1	1	1	0	Na			
Command	82h							

-Normal Outputs**Table 17: USA Navy NAVSO P-5239-26 command for normal output information**

Register	7	6	5	4	3	2	1	0
Error	Na							
Sector Count	Na							
LBA Low	Na							
LBA Mid	Na							
LBA High	Na							
Device	obs	Na	obs	DEV	Na	Na	Na	Na
Status	BSY	DRDY	DF	Na	DRQ	Na	Na	ERR

Device register-

DEV shall specify the selected device.

Status register

BSY will be cleared to zero indicating command completion

DRDY will be set to one.

DF (Device Fault) will be cleared to zero.

DRQ will be cleared to zero

ERR will be cleared to zero.

4. NSA Manual 130-2

This function is compliant with NSA Manual 130-2 specification.

Steps:

1. The whole disk is erased using Flash Erase Command.

2. The whole disk is filled with random data.
3. The whole disk is filled with random data again.
4. The whole disk is erased using Flash Erase Command. The whole disk is filled with fixed character pattern 0x55.

-Protocol: Non Data Command

-Inputs

Table 18: Execute NSA Manual 130-2 command for inputs information

Register	7	6	5	4	3	2	1	0
Features	25h							
Sector Count	41h							
LBA Low	Na							
LBA Mid	Na							
LBA High	Na							
Device	1	1	1	0	Na			
Command	82h							

-Normal Outputs

Table 19: NSA Manual 130-2 command for normal output information

Register	7	6	5	4	3	2	1	0
Error	Na							
Sector Count	Na							
LBA Low	Na							
LBA Mid	Na							
LBA High	Na							
Device	obs	Na	obs	DEV	Na	Na	Na	Na
Status	BSY	DRDY	DF	Na	DRQ	Na	Na	ERR

Device register-

DEV shall specify the selected device.

Status register

BSY will be cleared to zero indicating command completion

DRDY will be set to one.

DF (Device Fault) will be cleared to zero.

DRQ will be cleared to zero

ERR will be cleared to zero.

5. USA-Army 380-19

This function is compliant with USA-Army 380-19 specification.

Step:

1. The whole disk is erased using Flash Erase Command.
2. The whole disk is filled with random data.
3. The whole disk is filled with fixed character pattern 0x55.
4. The whole disk is filled with fixed character pattern 0xAA.

-Protocol: Non Data Command

-Inputs

Table 20: Execute USA Army 380-19 command for inputs information

Register	7	6	5	4	3	2	1	0
Features	26h							
Sector Count	41h							
LBA Low	Na							
LBA Mid	Na							
LBA High	Na							
Device	1	1	1	0	Na			
Command	82h							

-Normal Outputs

Table 21: USA Army 380-19 command for normal output information

Register	7	6	5	4	3	2	1	0
Error	Na							
Sector Count	Na							
LBA Low	Na							
LBA Mid	Na							
LBA High	Na							
Device	obs	Na	obs	DEV	Na	Na	Na	Na
Status	BSY	DRDY	DF	Na	DRQ	Na	Na	ERR

Device register-

DEV shall specify the selected device.

Status register

BSY will be cleared to zero indicating command completion

DRDY will be set to one.

DF (Device Fault) will be cleared to zero.

DRQ will be cleared to zero

ERR will be cleared to zero.

6. NISPOMSUP Chap 8, Sect. 8-501

This function is compliant with NISPOMSUP Chap 8, Sect. 8-501 specification.

Steps:

1. The whole disk is filled with fixed character pattern 0x55.
2. The whole disk is filled with fixed character pattern 0xAA.
3. The whole disk is filled with random data.

-Protocol: Non Data Command

-Inputs

Table 22: Execute NISPOMSUP Chap 8, Sect. 8-501 command for inputs information

Register	7	6	5	4	3	2	1	0
Features	27h							
Sector Count	41h							
LBA Low	Na							
LBA Mid	Na							
LBA High	Na							
Device	1	1	1	0	Na			
Command	82h							

-Normal Outputs

Table 23: NISPOMSUP Chap 8, Sect. 8-501 command for normal output information

Register	7	6	5	4	3	2	1	0
Error	Na							
Sector Count	Na							
LBA Low	Na							
LBA Mid	Na							
LBA High	Na							
Device	obs	Na	obs	DEV	Na	Na	Na	Na
Status	BSY	DRDY	DF	Na	DRQ	Na	Na	ERR

Device register-

DEV shall specify the selected device.

Status register

BSY will be cleared to zero indicating command completion

DRDY will be set to one.

DF (Device Fault) will be cleared to zero.

DRQ will be cleared to zero

ERR will be cleared to zero.

7. NSA Manual 9-12

This function is compliant with NSA Manual 9-12 specification.

Step:

1. The whole disk is erased using Flash Erase Command.
2. The whole disk is filled with unclassified pattern.
3. Verify the overwrite procedure by randomly rereading the overwritten information.

-Protocol: Non Data Command

-Inputs

Table 24: Execute NSA Manual 9-12 command for inputs information

Register	7	6	5	4	3	2	1	0
Features	28h							
Sector Count	41h							
LBA Low	Na							
LBA Mid	Na							
LBA High	Na							
Device	1	1	1	0	Na			
Command	82h							

-Normal Outputs

Table 25: NSA Manual 9-12 command for normal output information

Register	7	6	5	4	3	2	1	0
Error	Na							
Sector Count	Na							
LBA Low	Na							
LBA Mid	Na							

LBA High	Na							
Device	obs	Na	obs	DEV	Na	Na	Na	Na
Status	BSY	DRDY	DF	Na	DRQ	Na	Na	ERR

Device register-

DEV shall specify the selected device.

Status register

BSY will be cleared to zero indicating command completion

DRDY will be set to one.

DF (Device Fault) will be cleared to zero.

DRQ will be cleared to zero

ERR will be cleared to zero.

8. IRIG1006

This function is compliant with IRIG106 specification.

Step:

1. The whole disk is erased using Flash Erase Command.
2. The whole disk is filled with pattern 0x55, and read back to verify.
3. The whole disk is erased using Flash Erase Command.
4. The whole disk is filled with pattern 0xAA, and read back to verify.
5. The whole disk is erased using Flash Erase Command.
6. Write 0x00 to all bad blocks. If there is any bit is still 1, the page is re-written 0 again. This procedure this repeated up to 16 times.
7. Erase all bad blocks and checked to determine if any zero are found. If any zeros are found, erase this block again. This procedure this repeated up to 16 times.
8. Write "Secure Erase" string to all blocks.

-Protocol: Non Data Command

-Inputs

Table 26: Execute IRIG160 command for inputs information

Register	7	6	5	4	3	2	1	0
Features	29h							

Sector Count	41h				
LBA Low	Na				
LBA Mid	Na				
LBA High	Na				
Device	1	1	1	0	Na
Command	82h				

-Normal Outputs

Table 27: IRIG160 command for normal output information

Register	7	6	5	4	3	2	1	0
Error	Na							
Sector Count	Na							
LBA Low	Na							
LBA Mid	Na							
LBA High	Na							
Device	obs	Na	obs	DEV	Na	Na	Na	Na
Status	BSY	DRDY	DF	Na	DRQ	Na	Na	ERR

Device register-

DEV shall specify the selected device.

Status register

BSY will be cleared to zero indicating command completion

DRDY will be set to one.

DF (Device Fault) will be cleared to zero.

DRQ will be cleared to zero

ERR will be cleared to zero.

3.10 Destroy (Unrecoverable Destroy)

Innodisk Unrecoverable Destroy function implements an ultimate data erase of the SSD. Once Unrecoverable Destroy is triggered, beside all the user data and SSD information, also SSD firmware will be erased and which is unusable. Destroy is optional and available for customization.

3.10.1 Unrecoverable Destroy Command

-Protocol: Non Data Command

-Inputs

Table 28: Execute Unrecoverable Destroy command for inputs information

Register	7	6	5	4	3	2	1	0
Features	20h							
Sector Count	41h							
LBA Low	Na							
LBA Mid	Na							
LBA High	Na							
Device	1	1	1	0	Na			
Command	82h							

-Normal Outputs

Table 29: Unrecoverable Destroy command for normal output information

Register	7	6	5	4	3	2	1	0
Error	Na							
Sector Count	Na							
LBA Low	Na							
LBA Mid	Na							
LBA High	Na							
Device	obs	Na	obs	DEV	Na	Na	Na	Na
Status	BSY	DRDY	DF	Na	DRQ	Na	Na	ERR

Device register-

DEV shall specify the selected device.

Status register

BSY will be cleared to zero indicating command completion

DRDY will be set to one.

DF (Device Fault) will be cleared to zero.

DRQ will be cleared to zero

ERR will be cleared to zero.

4. Installation Requirements

4.1 1.8" SATA SSD 3MR3-P Pin Directions

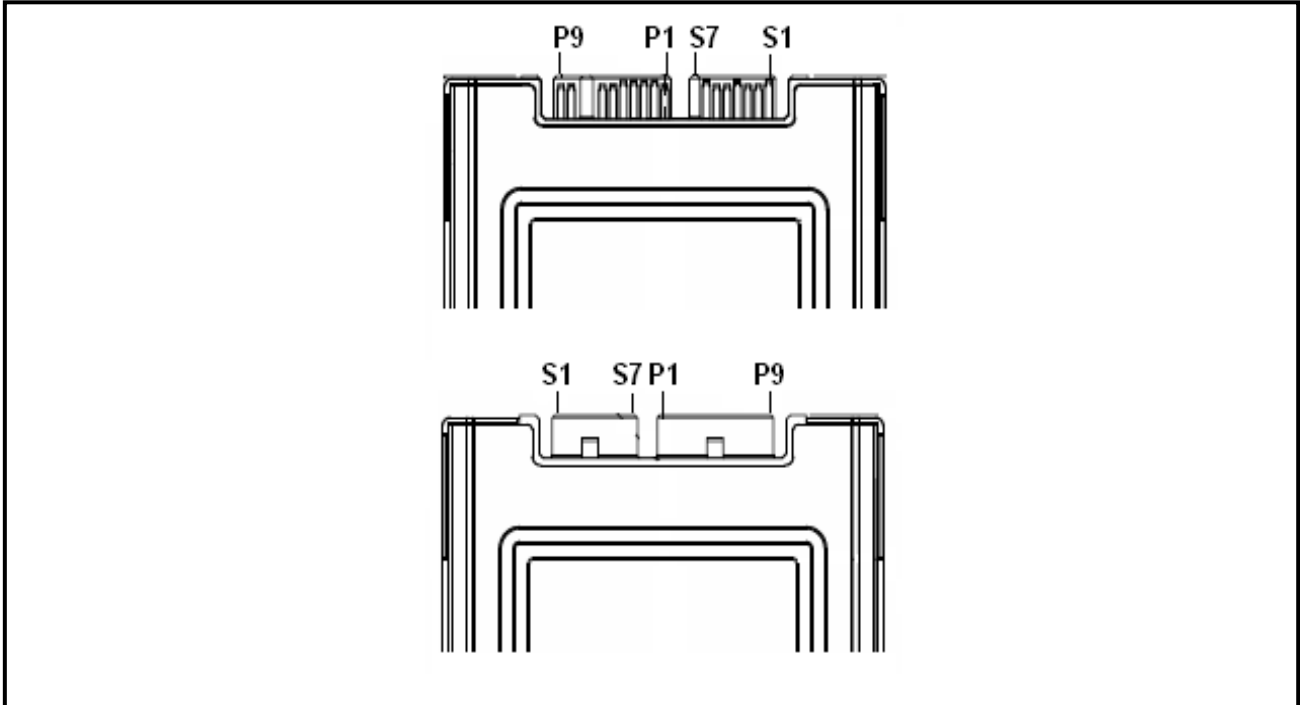

Figure 3: Signal Segment and Power Segment

4.2 Electrical Connections for 1.8" SATA SSD 3MR3-P

A Serial ATA device may be either directly connected to a host or connected to a host through a cable. For connection via cable, the cable should be no longer than 1meter. The SATA interface has a separate connector for the power supply. Please refer to the pin description for further details.

4.3 Device Drive

No additional device drives are required. Innodisk 1.8" SATA SSD 3MR3-P can be configured as a boot device.

5. Part Number Rule

CODE	1	2	3	4	5	6	7	8	9	10	11	12	13	14	15	16	17	18	19	20
	D	R	S	1	8	-	B	5	6	D	7	0	B	C	1	Q	C	-	X	X
Definition																				
Code 1st (Disk)											Code 13th (Flash Mode)									
D : Disk											B: Toshiba 15nm Sync. Flash									
Code 2nd ~ 5th (Form Factor)											Code 14th (Operation Temperature)									
RS18: 1.8" SATA SSD 3MR3-P											C: Standard Grade (0°C ~ +70°C)									
											W: Industrial Grade (-40°C ~ +85°C)									
Code 7th ~9th (Capacity)											Code 15th (Internal Control)									
08G: 8GB											1: PCB version									
16G: 16GB																				
32G: 32GB											Code 16th (Channel of Data Transfer)									
64G: 64GB											S: Single Channel									
A28: 128GB											D: Dual Channels									
B56: 256GB											Q: Quad Channels									
C12: 512GB																				
Code 10th ~12th (Controller)											Code 17th (Flash Type)									
D70: ID170											C: Toshiba MLC									
											Code 19th~20th (Customized Code)									

Appendix

innodisk

宜鼎國際股份有限公司 Innodisk Corporation

Tel:(02)7703-3000 Fax:(02) 7703-3555 Internet: http://www.innodisk.com/

RoHS 自我宣告書 (RoHS Declaration of Conformity)

Manufacturer Product: All Innodisk EM Flash and Dram products

- 一、 宜鼎國際股份有限公司（以下稱本公司）特此保證售予貴公司之所有產品，皆符合歐盟 2011/65/EU 關於 RoHS 之規範要求。

Innodisk Corporation declares that all products sold to the company, are complied with European Union RoHS Directive (2011/65/EU) requirement

- 二、 本公司同意因本保證書或與本保證書相關事宜有所爭議時，雙方宜友好協商，達成協議。

Innodisk Corporation agrees that both parties shall settle any dispute arising from or in connection with this Declaration of Conformity by friendly negotiations.

Name of hazardous substance	Limited of RoHS ppm (mg/kg)
Cd	< 100 ppm
Pb	< 1000 ppm
Hg	< 1000 ppm
Chromium VI (Cr+6)	< 1000 ppm
Polybromodiphenyl ether (PBDE)	< 1000 ppm
Polybrominated Biphenyls (PBB)	< 1000 ppm

立保證書人 (Guarantor)

Company name 公司名稱： Innodisk Corporation 宜鼎國際股份有限公司

Company Representative 公司代表人： Richard Lee 李鐘亮

Company Representative Title 公司代表人職稱： CEO 執行長

Date 日期： 2014 / 07 / 29



(Company Stamp/公司大小章)

innodisk

宜鼎國際股份有限公司
Innodisk Corporation

Tel:(02)7703-3000 Fax:(02) 7703-3555 Internet: <http://www.innodisk.com/>

REACH Declaration of Conformity

Manufacturer Product: All Innodisk EM Flash and Dram products

1.宜鼎國際股份有限公司（以下稱本公司）特此保證此售予貴公司之產品，皆符合歐盟化學品法案(Registration , Evaluation and Authorization of Chemicals ; REACH)之規定

(<http://www.echa.europa.eu/de/candidate-list-table> last updated: 16/05/2014)。所提供之產品包含：(1) 產品或產品所使用到的所有原物料；(2)包裝材料；(3)設計、生產及重工過程中所使用到的所有原物料。

We Innodisk Corporation hereby declare that our products are in compliance with the requirements according to the REACH Regulation

(<http://www.echa.europa.eu/de/candidate-list-table> last updated: 16/06/2014).

Products include : 1) Product and raw material used by the product ; 2) Packaging material ; 3) Raw material used in the process of design, production and rework

2.本公司同意因本保證書或與本保證書相關事宜有所爭議時，雙方宜友好協商，達成協議。

InnoDisk Corporation agrees that both parties shall settle any dispute arising from or in connection with this Declaration of Conformity by friendly negotiations.

立保證書人 (Guarantor)

Company name 公司名稱： InnoDisk Corporation 宜鼎國際股份有限公司

Company Representative 公司代表人： Richard Lee 李鐘亮

Company Representative Title 公司代表人職稱： CEO 執行長

Date 日期： 2014 / 07 / 29



Certificate

Issue Date: March 1, 2016
Ref. Report No. ISL-16LE078CE

Product Name : 1.8" SATA SSD
Model(s) : 1.8" SATA SSD 3\$*#-&
(\$:Flash type: (S:SLC,I:iSLC,M:MLC);
*:Product line: (E:Embedded, G:EverGreen, R:InnoRobust);
#:Controller: (empty:106/107/167, 2:201/202, 3:108/109/170, 4~9:Others)
&:Product feature: (P:with DRAM, empty:without DRAM)

Responsible Party : Innodisk Corporation
Address : 5F., No.237, Sec. 1, Datong Rd., Xizhi Dist., New Taipei City 221,
Taiwan (R.O.C.)

We, **International Standards Laboratory**, hereby certify that:

The device bearing the trade name and model specified above has been shown to comply with the applicable technical standards as indicated in the measurement report and was tested in accordance with the measurement procedures specified in European Council Directive- EMC Directive 2004/108/EC (marketed before 2016/04/19) 2014/30/EU (marketed after 2016/04/20). The device was passed the test performed according to :



Standards:

EN 55022: 2010+AC2011 and CISPR 22: 2008 (modified)
EN 61000-3-2:2014 and IEC 61000-3-2:2014
EN 61000-3-3: 2013 and IEC 61000-3-3: 2013
EN 55024: 2010 and CISPR 24: 2010
EN 61000-4-2: 2009 and IEC 61000-4-2: 2008
EN 61000-4-3: 2006+A1: 2008 +A2: 2010 and
IEC 61000-4-3:2006+A1: 2007+A2: 2010
EN 61000-4-4:2012 and IEC 61000-4-4:2012

I attest to the accuracy of data and all measurements reported herein were performed by me or were made under my supervision and are correct to the best of my knowledge and belief. I assume full responsibility for the completeness of these measurements and vouch for the qualifications of all persons taking them.

International Standards Laboratory

W.H. Chang / Director

Hsi-Chih LAB:

No. 65, Gu Dai Keng Street, Hsi-Chih Dist.,
New Taipei City 221, Taiwan
Tel: 886-2-2646-2550; Fax: 886-2-2646-4641



Lung-Tan LAB:

No. 120, Lane 180, Hsin Ho Rd., Lung-Tan Dist.,
Tao Yuan City 325, Taiwan
Tel: 886-3-407-1718; Fax: 886-3-407-1738



Certificate

Issue Date: March 1, 2016
 Ref. Report No. ISL-16LE078FB

Product Name : 1.8" SATA SSD
 Model(s) : 1.8" SATA SSD 3\$*#-&
 (\$:Flash type: (S:SLC,I:iSLC,M:MLC);
 *:Product line: (E:Embedded, G:EverGreen, R:InnoRobust);
 #:Controller: (empty:106/107/167, 2:201/202, 3:108/109/170, 4~9:Others)
 &:Product feature: (P:with DRAM, empty:without DRAM)

Applicant : Innodisk Corporation
 Address : 5F., No.237, Sec. 1, Datong Rd., Xizhi Dist., New Taipei City 221,
 Taiwan (R.O.C.)

We, **International Standards Laboratory**, hereby certify that:

The device bearing the trade name and model specified above has been shown to comply with the applicable technical standards as indicated in the measurement report and was tested in accordance with the measurement procedures specified. (refer to Test Report if any modifications were made for compliance).



Standards:

FCC CFR Title 47 Part 15 Subpart B: 2014- Section 15.107 and 15.109
 ANSI C63.4-2014
 Industry Canada Interference-Causing Equipment Standard ICES-003 Issue 6: 2016

Class B

I attest to the accuracy of data and all measurements reported herein were performed by me or were made under my supervision and are correct to the best of my knowledge and belief. I assume full responsibility for the completeness of these measurements and vouch for the qualifications of all persons taking them.

International Standards Laboratory

W.H. Chang / Director

Hsi-Chih LAB:
 No. 65, Gu Dai Keng Street, Hsi-Chih Dist.,
 New Taipei City 221, Taiwan
 Tel: 886-2-2646-2550; Fax: 886-2-2646-4641



Lung-Tan LAB:
 No. 120, Lane 180, Hsin Ho Rd., Lung-Tan Dist.,
 Tao Yuan City 325, Taiwan
 Tel: 886-3-407-1718; Fax: 886-3407-1738

