

1.8" SATA SSD

3SR-P Series

Customer: _____
Customer
Part
Number: _____
Innodisk
Part
Number: _____
Innodisk
Model Name: _____
Date: _____

Innodisk Approver	Customer Approver

**Total Solution For
Industrial Flash Storage**

Table of contents

REVISION HISTORY	4
LIST OF FIGURES	6
1. PRODUCT OVERVIEW	7
1.1 INTRODUCTION OF INNODISK 1.8" SATA SSD 3SR-P	7
1.2 PRODUCT VIEW AND MODELS	7
1.3 SATA INTERFACE	7
1.4 1.8-INCH FORM FACTOR	8
2. PRODUCT SPECIFICATIONS.....	9
2.1 CAPACITY AND DEVICE PARAMETERS.....	9
2.2 PERFORMANCE	9
2.3 ELECTRICAL SPECIFICATIONS	9
2.3.1 Power Requirement	9
2.3.2 Power Consumption.....	9
2.4 ENVIRONMENTAL SPECIFICATIONS	10
2.4.1 Temperature Ranges	10
2.4.2 Humidity	10
2.4.3 Shock and Vibration.....	10
2.4.4 Mean Time Between Failures (MTBF).....	10
1.8 CE AND FCC COMPATIBILITY	11
2.6 RoHS COMPLIANCE	11
2.7 RELIABILITY.....	11
2.8 TRANSFER MODE	11
2.9 PIN ASSIGNMENT	11
2.10 MECHANICAL DIMENSIONS	12
2.11 ASSEMBLY WEIGHT	13
2.12 SEEK TIME	13
2.13 HOT PLUG	13
2.14 NAND FLASH MEMORY	13
3. THEORY OF OPERATION	14
3.1 OVERVIEW	14
3.2 SATA III CONTROLLER	14
3.3 ERROR DETECTION AND CORRECTION.....	15
3.4 WEAR-LEVELING	15
3.5 BAD BLOCKS MANAGEMENT.....	15
3.6 POWER CYCLING	15
3.7 GARBAGE COLLECTION/TRIM.....	15

- 4. INSTALLATION REQUIREMENTS 16**
 - 4.1 1.8" SATA SSD 3SR-P PIN DEFINITION 16**
 - 4.2 ELECTRICAL CONNECTIONS FOR 1.8" SATA SSD 3SR-P 16**
 - 4.3 FORM FACTOR 16**
 - 4.4 DEVICE DRIVER 16**
- 5. PART NUMBER RULE 17**
- 6. APPENDIX 18**

REVISION HISTORY

Revision	Description	Date
Preliminary	First Released	Dec., 2013
Rev. 1.0	<ol style="list-style-type: none">1. Update performance2. Update power consumption3. Add CE/FCC certificates4. Update TBW	Apr., 2014
Rev. 1.1	Add specification of Quick Erase function	Nov., 2014
Rev. 1.2	Modify TBW based on NAND Flash specifications	Jan., 2015
Rev. 1.3	Update PCB version	March, 2017

List of Tables

TABLE 1: DEVICE PARAMETERS	9
TABLE 2: PERFORMANCE	9
TABLE 3: INNODISK 1.8" SATA SSD 3SR-P POWER REQUIREMENT	9
TABLE 4: POWER CONSUMPTION.....	9
TABLE 5: TEMPERATURE RANGES FOR 1.8" SATA SSD 3SR-P.....	10
TABLE 6: SHOCK/VIBRATION TESTING FOR 1.8" SATA SSD 3SR-P	10
TABLE 7: 1.8" SATA SSD 3SR-P MTBF.....	10
TABLE 8: INNODISK 1.8" SATA SSD 3SR-P PIN ASSIGNMENT	11

List of Figures

FIGURE 1: INNODISK 1.8" SATA SSD 3SR-P	7
FIGURE 2: INNODISK FiD 1.8" SATA SSD 3SR-P BLOCK DIAGRAM	14
FIGURE 3: SIGNAL SEGMENT AND POWER SEGMENT	16

1. Product Overview

1.1 Introduction of Innodisk 1.8" SATA SSD 3SR-P

Innodisk 1.8" SATA SSD 3SR-P products provide high capacity flash memory Solid State Drive (SSD) that electrically complies with the Serial ATA (SATA) standard. Innodisk 1.8" SATA SSD 3SR-P is a SATA III 6.0Gb/s flash based disk, which delivers excellent performance and reliability. Especially, it comes with several data security functions, including QEraser/ SEraser (optional)/ Destroy(optional) and also Write Protect(optional). All the security functions can be triggered by hardware and software approaches. 1.8" SATA SSD 3SR-P is compliant with MIL-STD-810F/G standards. The SSD is equipped ruggedized hardware design and thus it can perform well in the harsh environment. Innodisk 1.8" SATA SSD 3SR-P is designed for industrial applications, and supports several SATA features, including NCQ and S.M.A.R.T. Innodisk 1.8" SATA SSD are designed to have good performance with no latency. It will effectively reduce the boot up time of the operation system. The power consumption is also much lower than a traditional hard disk drive (HDD).

1.2 Product View and Models

Innodisk 1.8" SATA SSD 3SR-P is available in follow capacities:

1.8" SATA SSD 3SR-P 8GB	1.8" SATA SSD 3SR-P 64GB
1.8" SATA SSD 3SR-P 16GB	1.8" SATA SSD 3SR-P 128GB
1.8" SATA SSD 3SR-P 32GB	1.8" SATA SSD 3SR-P 256GB



Figure 1: Innodisk 1.8" SATA SSD 3SR-P

1.3 SATA Interface

Innodisk 1.8" SATA SSD 3SR-P supports SATA III interface, and is backward compatible with SATA I and SATA II. The SATA III interface can also work with Serial Attached SCSI (SAS) host system, which are located on server motherboards. Innodisk 1.8" SATA SSD 3SR-P is compliant with Serial ATA Gen 1, Gen 2 and Gen 3 specification (Gen 3 supports 1.5Gbps /3.0Gbps/6.0Gbps data rate). The SATA connector uses a 7-pin signal segment and a 9-pin power segment.

1.4 1.8-inch Form Factor

The Industry-standard 1.8-inch form factor is designed with a metal case because the 1.8-inch is a popular form factor in industrial applications. 1.8-inch is also same form factor for most laptop hard disk drives. Innodisk 1.8" SATA SSD 3SR-P has a compact size measuring 54.0mm (W) x78.5mm (L) x 5.00mm (H).

2. Product Specifications

2.1 Capacity and Device Parameters

1.8" SATA SSD 3SR-P device parameters are shown in Table 1.

Table 1: Device parameters

Capacity	LBA	Cylinders	Heads	Sectors	User Capacity(MB)
8GB	13695696	13587	16	63	6687
16GB	29323728	16383	16	63	14318
32GB	60579792	16383	16	63	29580
64GB	121138416	16383	16	63	59150
128GB	242255664	16383	16	63	118289
256GB	484490160	16383	16	63	236568

2.2 Performance

Burst Transfer Rate: 6.0Gbps

Table 2: Performance

Capacity	8GB	16GB	32GB	64GB	128GB	256GB
Sequential Read (max.)	400MB/sec	400 MB/sec	460MB/sec	460 MB/sec	475 MB/sec	490 MB/sec
Sequential Write (max.)	110 MB/sec	130 MB/sec	240 MB/sec	330 MB/sec	340 MB/sec	340 MB/sec

Note: Based on CrystalDiskMark 3.01 with file size 1000MB

2.3 Electrical Specifications

2.3.1 Power Requirement

Table 3: Innodisk 1.8" SATA SSD 3SR-P Power Requirement

Item	Symbol	Rating	Unit
Input Voltage	V _{IN}	+5 DC +- 5%	V

2.3.2 Power Consumption

Table 4: Power Consumption

Mode	Power Consumption (mA)
Read	450 (max.)
Write	600 (max.)
Idle	190 (max.)

* Target: 1.8" SATA SSD 3SR-P 256GB

2.4 Environmental Specifications

2.4.1 Temperature Ranges

Table 5: Temperature ranges for 1.8" SATA SSD 3SR-P

Temperature	Range
Operating	Standard Grade: 0°C to +70°C
	Industrial Grade: -40°C to +85°C
Storage	-55°C to +95°C

2.4.2 Humidity

Relative Humidity: 10-95%, non-condensing

2.4.3 Shock and Vibration

Table 6: Shock/Vibration Testing for 1.8" SATA SSD 3SR-P

Reliability	Test Conditions	Reference Standards
Vibration	7 Hz to 2K Hz, 20G, 3 axis	IEC 68-2-6
Mechanical Shock	Duration: 0.5ms, 1500 G, 3 axis	IEC 68-2-27

2.4.4 Mean Time Between Failures (MTBF)

Table 7 summarizes the MTBF prediction results for various 1.8" SATA SSD 3SR-P configurations. The analysis was performed using a RAM Commander™ failure rate prediction.

- **Failure Rate:** The total number of failures within an item population, divided by the total number of life units expended by that population, during a particular measurement interval under stated conditions.
- **Mean Time Between Failures (MTBF):** A basic measure of reliability for repairable items: The mean number of life units during which all parts of the item will perform within their specified limits, during a particular measurement interval under stated conditions.

Table 7: 1.8" SATA SSD 3SR-P MTBF

Product	Condition	MTBF (Hours)
Innodisk 1.8" SATA SSD 3SR-P	Telcordia SR-332 GB, 25°C	>3,000,000

1.8 CE and FCC Compatibility

1.8" SATA SSD 3SR-P conforms to CE and FCC requirements.

2.6 RoHS Compliance

1.8" SATA SSD 3SR-P is fully compliant with the RoHS directive.

2.7 Reliability

Parameter	Value
Read Cycles	Unlimited Read Cycles
Wear-Leveling Algorithm	Supported
Bad Blocks Management	Supported
Error Correcting Code	Supported
TBW (Unit: TB)	
8GB	432 (Sequential Write)
16GB	864 (Sequential Write)
32GB	1728 (Sequential Write)
64GB	3456 (Sequential Write)
128GB	6912 (Sequential Write)
256GB	13824 (Sequential Write)

2.8 Transfer Mode

1.8" SATA SSD 3SR-P support following transfer mode:

Serial ATA III 6.0Gbps

Serial ATA II 3.0Gbps

Serial ATA I 1.5Gbps

2.9 Pin Assignment

Innodisk 1.8" SATA SSD 3SR-P uses the standard SATA pin-out. See Table 8 for 1.8" SATA SSD 3SR-P pin assignment.

Table 8: Innodisk 1.8" SATA SSD 3SR-P Pin Assignment

Name	Type	Description
S1	GND	NA
S2	A+	Differential Signal Pair A
S3	A-	
S4	GND	NA
S5	B-	Differential Signal Pair B
S6	B+	
S7	GND	NA
Key and Spacing separate the signal and power segments		

P1	V33	3.3V Power
P2	V33	3.3V Power, Pre-charge
P3	GND	
P4	GND	
P5	V5	5V Power, Pre-charge
P6	V5	5V Power
P7	R	Reserved
Key	Key	Key
P8	Optional	Vendor Specific
P9	QE	*Quick Erase
<p>Note:</p> <p>* Active low "Quick Erase", the SSD will be triggered the QEraser function</p>		

2.10 Mechanical Dimensions

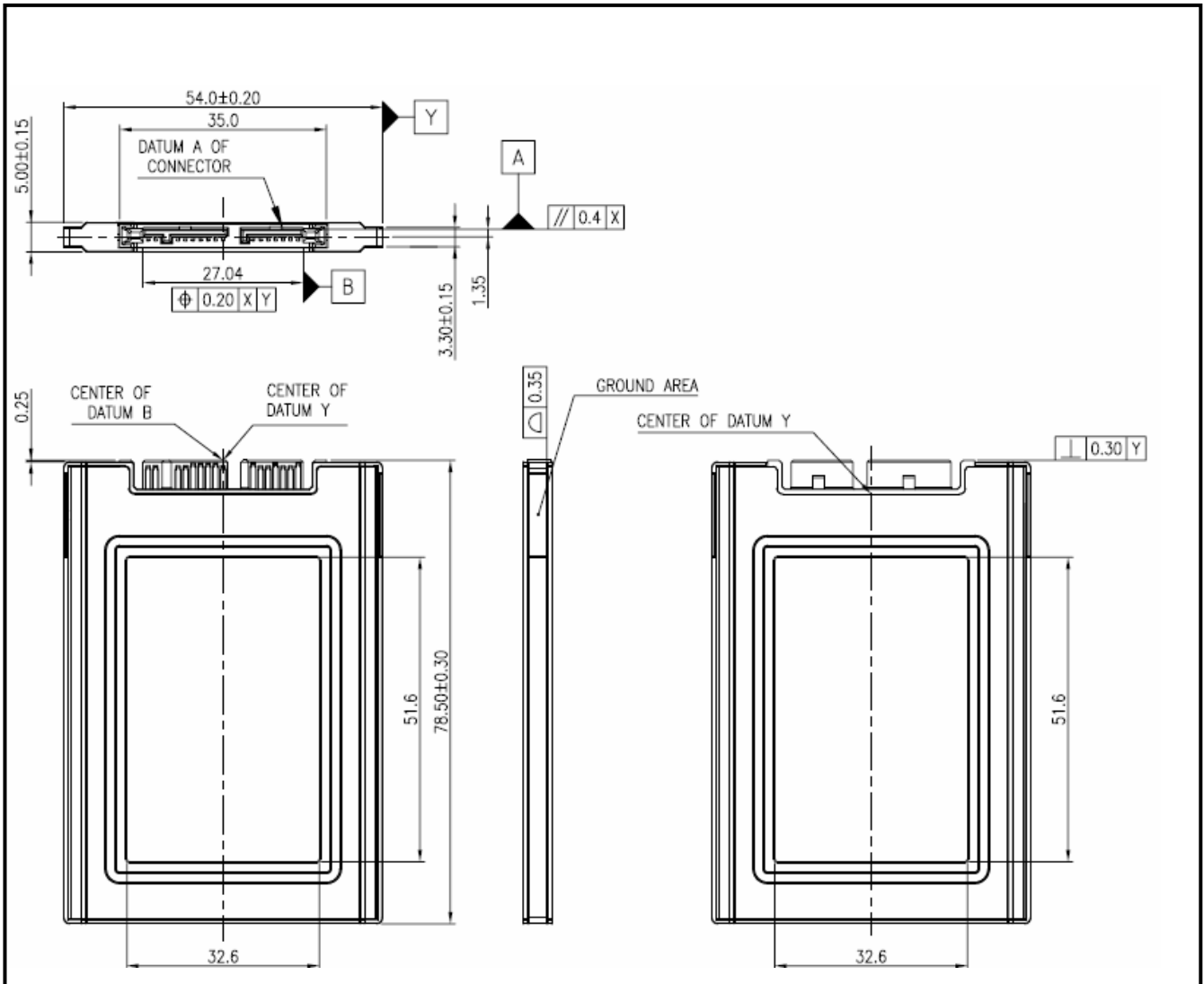

2.11 Assembly Weight

The Innodisk 1.8" SATA SSD 3SR-P with SLC flash ICs weighs approximately 40 grams for 8GB capacities. The total weight of SSD will be less than 45 grams.

2.12 Seek Time

Innodisk 1.8" SATA SSD 3SR-P does not have magnetic rotating motor so there is no seek or rotational latency for this drive.

2.13 Hot Plug

The SSD supports the hot plug function and can be removed or connected when the system is powered on. The user has to avoid hot plugging the SSD when it is configured as the boot drive with the operating system installed.

Surprise hot plug : The insertion of a SATA device into a backplane (combine signal and power) that has power present. The device powers up and initiates an OOB sequence.

Surprise hot removal: The removal of a SATA device from a powered backplane, without first being disabled.

2.14 NAND Flash Memory

Innodisk 1.8" SATA SSD 3SR-P uses Single-Level Cell (SLC) NAND flash memory, which is non-volatile and highly reliable.

3. Theory of Operation

3.1 Overview

Figure 2 shows the operation of Innodisk 1.8" SATA SSD 3SR-P from the system level, including the major hardware blocks.

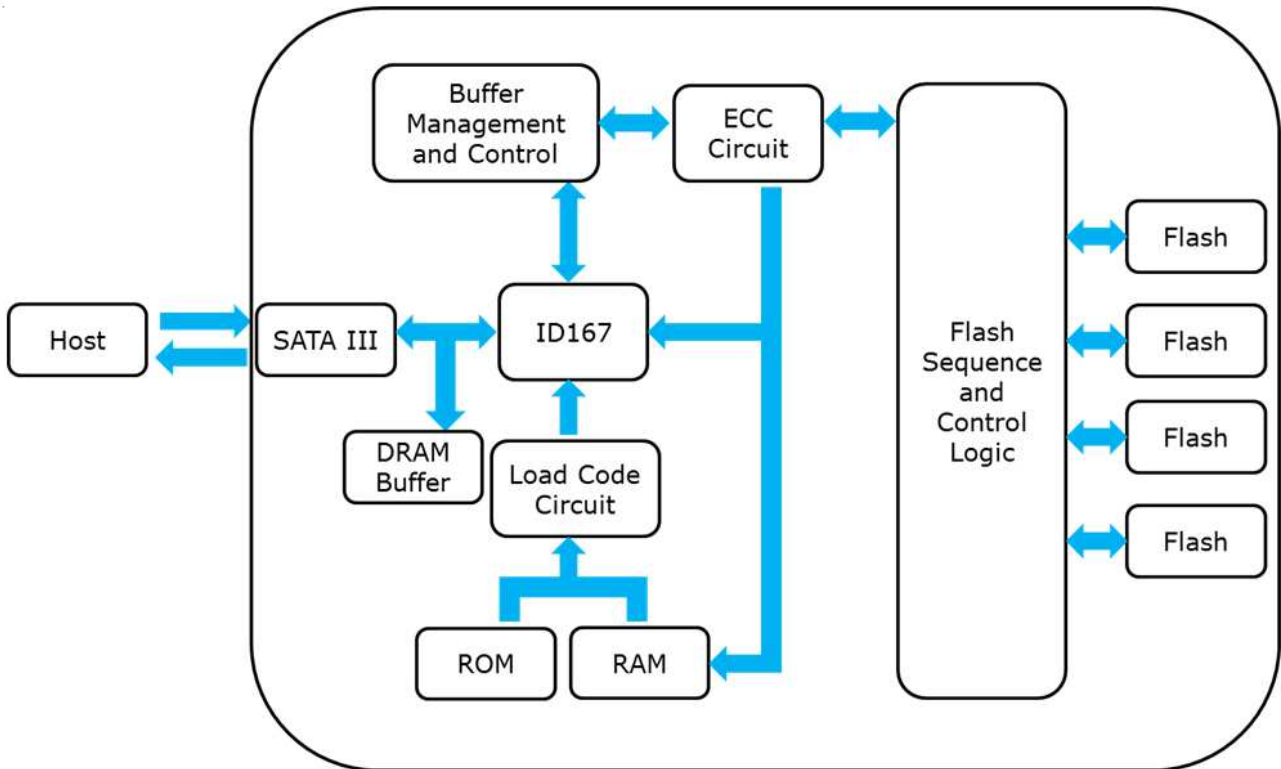

Figure 2: Innodisk FiD 1.8" SATA SSD 3SR-P Block Diagram

Innodisk 1.8" SATA SSD 3SR-P integrates a SATA III controller and NAND flash memory. Communication with the host occurs through the host interface using standard Serial ATA protocol. Communication with the flash memory occurs through Innodisk's SATA III controller.

3.2 SATA III Controller

Innodisk 1.8" SATA SSD 3SR-P is designed with ID 167, a SATA III 6.0Gbps (Gen. 3) controller. The Serial ATA physical link and transport layers are compliant with Serial ATA Gen 1, Gen 2 and Gen 3 specification (Gen 3 supports 1.5Gbps/3.0Gbps/6.0Gbps data rate). The controller has a four channel bandwidth for accessing the NAND flash memory.

3.3 Error Detection and Correction

Highly sophisticated Error Correcting Code algorithms are implemented into the controller. The ECC unit consists of the parity unit (parity-byte generation) and the syndrome unit (syndrome-byte computation). These units implement an algorithm that can correct 40 bits per 1024 bytes in an ECC block. Code-byte generation during write operations, as well as error detection during read operation, is implemented on the fly without any decrease in performance.

3.4 Wear-Leveling

Flash memory can be only be erased a limited number of times. This number is called the **erase cycle limit** or **write endurance limit** and is defined by the NAND flash memory vendor. The erase cycle limit applies to each individual block in the flash device.

Innodisk 1.8" SATA SSD 3SR-P uses a static wear-leveling algorithm to ensure that consecutive writes of a specific sector are not written physically to the same page/block in the flash. This spreads data usage evenly across all blocks while prolonging the lifecycle of the NAND flash memory.

3.5 Bad Blocks Management

Bad Blocks are blocks that contain one or more invalid bits whose reliability are not guaranteed. Bad Blocks may be present when the SSD is shipped, and may also develop over the lifetime of the SSD. When Bad Blocks are detected, it will be flagged so that block will not be used anymore. Bad Block management, Bad Block replacement, and Error Correcting Code are implemented to avoid storing/accessing data errors. These functions are enabled automatically to transfer data from Bad Blocks to spare blocks, and also correct error bits.

3.6 Power Cycling

Innodisk's power cycling management is a complete data protection system that functions before and after a sudden loss of power to Innodisk's SSD. A Low-power detection circuit terminates data writes before an abnormal power cycle. Once power is restored, table-remapping deletes corrupted data to maintain data integrity. Innodisk's power cycling management also prevents data stored in flash from degrading overtime.

3.7 Garbage Collection/TRIM

Garbage collection and TRIM technology is used to maintain performance consistency by continuously cleaning blocks marked for deletion on SSDs. The garbage collection runs as a background process to have a minimal impact on the controller's resources while combining valid data into available blocks, and erasing blocks marked for deletion. This process also significantly

reduces write operations to the drive, thereby increasing the SSD's lifespan.

4. Installation Requirements

4.1 1.8" SATA SSD 3SR-P Pin Definition

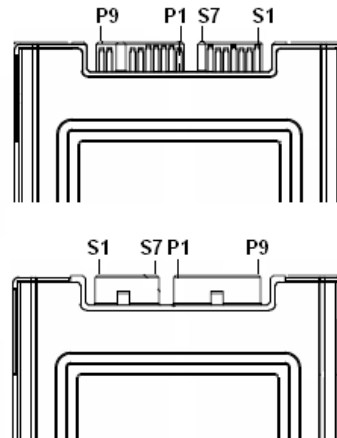

Figure 3: Signal Segment and Power Segment

4.2 Electrical Connections for 1.8" SATA SSD 3SR-P

A Serial ATA device can be connected to a host system through a cable. The cable should not be longer than one meter. The SATA interface also has a separate connector for the power supply. Please refer to the pin description on Table 8 for further details.

4.3 Form Factor

Please turn off your computer, and open your computer's case. Find one of available 1.8-inch slot, and connect the 1.8" SATA SSD with your computer or connect the SATA data cable, and power cable from your power supply. Please boot the installation Operation System from CD-ROM, and install Operation System into SSD.

4.4 Device Driver

No additional device drivers are required. Innodisk 1.8" SATA SSD 3SR-P can be configured as a boot device or storage device.

5. Part Number Rule

CODE	1	2	3	4	5	6	7	8	9	10	11	12	13	14	15	16	17	18	19	20
	D	R	S	1	8	-	B	5	6	D	6	7	S	C	B	Q	B	-	X	X
Description	Disk	1.8" SATA SSD 3SR-P					Capacity			Category			Flash Mode	Operation Temp.	Internal Control	CH.	Flash	-	Customization Code	
Definition																				
Code 1st (Disk)											Code 13th (Flash Mode)									
D : Disk											S: Synchronous Flash									
Code 2nd (Feature Set)											Code 14th (Operation Temperature)									
R: InnoRobust											C: Standard Grade (0°C ~ +70°C)									
											W: Industrial Grade (-40°C ~ +85°C)									
Code 3rd ~ 5th (Form Factor)																				
S18:1.8" SSD											Code 15th (Internal Control)									
											B: PCB version									
Code 7th ~ 9th (Capacity)											Code 16th (Channel of data transfer)									
											Q: Quad Channels									
08G: 8GB																				
16G: 16GB																				
32G: 32GB																				
64G: 64GB											Code 17th (Flash Type)									
A28: 128GB											B: Toshiba SLC									
B56: 256GB																				
Code 10th ~ 12th (Series)											Code 19th ~ 20th (Customization Code)									
D67: 1.8" SATA SSD 3SR-P																				

6. Appendix

innodisk

宜鼎國際股份有限公司 Innodisk Corporation

Tel:(02)7703-3000 Fax:(02) 7703-3555 Internet: http://www.innodisk.com/

RoHS 自我宣告書(RoHS Declaration of Conformity)

Manufacturer Product: All Innodisk EM Flash and Dram products

- 一、 宜鼎國際股份有限公司（以下稱本公司）特此保證售予貴公司之所有產品，皆符合歐盟 2011/65/EU 關於 RoHS 之規範要求。

Innodisk Corporation declares that all products sold to the company, are complied with European Union RoHS Directive (2011/65/EU) requirement

- 二、 本公司同意因本保證書或與本保證書相關事宜有所爭議時，雙方宜友好協商，達成協議。

Innodisk Corporation agrees that both parties shall settle any dispute arising from or in connection with this Declaration of Conformity by friendly negotiations.

Name of hazardous substance	Limited of RoHS ppm (mg/kg)
Cd	< 100 ppm
Pb	< 1000 ppm
Hg	< 1000 ppm
Chromium VI (Cr+6)	< 1000 ppm
Polybromodiphenyl ether (PBDE)	< 1000 ppm
Polybrominated Biphenyls (PBB)	< 1000 ppm

立保證書人 (Guarantor)

Company name 公司名稱：Innodisk Corporation 宜鼎國際股份有限公司

Company Representative 公司代表人：Richard Lee 李鐘亮

Company Representative Title 公司代表人職稱：CEO 執行長

Date 日期：2014 / 07 / 29



innodisk

宜鼎國際股份有限公司
Innodisk Corporation

Tel:(02)7703-3000 Fax:(02) 7703-3555 Internet: <http://www.innodisk.com/>

REACH Declaration of Conformity

Manufacturer Product: All Innodisk EM Flash and Dram products

1.宜鼎國際股份有限公司（以下稱本公司）特此保證此售予貴公司之產品，皆符合歐盟化學品法案(Registration , Evaluation and Authorization of Chemicals ; REACH)之規定

(<http://www.echa.europa.eu/de/candidate-list-table> last updated: 16/05/2014)。所提供之產品包含：(1) 產品或產品所使用到的所有原物料；(2)包裝材料；(3)設計、生產及重工過程中所使用到的所有原物料。

We Innodisk Corporation hereby declare that our products are in compliance with the requirements according to the REACH Regulation

(<http://www.echa.europa.eu/de/candidate-list-table> last updated: 16/06/2014).

Products include : 1) Product and raw material used by the product ; 2) Packaging material ; 3) Raw material used in the process of design, production and rework

2.本公司同意因本保證書或與本保證書相關事宜有所爭議時，雙方宜友好協商，達成協議。

InnoDisk Corporation agrees that both parties shall settle any dispute arising from or in connection with this Declaration of Conformity by friendly negotiations.

立保證書人 (Guarantor)

Company name 公司名稱：InnoDisk Corporation 宜鼎國際股份有限公司

Company Representative 公司代表人：Richard Lee 李鐘亮

Company Representative Title 公司代表人職稱：CEO 執行長

Date 日期：2014 / 07 / 29







Certificate

Issue Date: November 12, 2013
 Ref. Report No. ISL-13LE406FB
 Product Name : 1.8" SATA SSD 3SR-P/3MR-P/3ME/3SE/3SE-P
 Model(s) : DRS18-XXND67*#%*&; DES18-XXND06*#%*&;
 DES18-XXND67*#%*&
 Brand : Innodisk
 Applicant : Innodisk Corporation
 Address : 9F, No. 100, Sec. 1 Xintai 5th Rd., Xizhi City, Taipei 221, Taiwan

We, International Standards Laboratory, hereby certify that:

The device bearing the trade name and model specified above has been shown to comply with the applicable technical standards as indicated in the measurement report and was tested in accordance with the measurement procedures specified. (refer to Test Report if any modifications were made for compliance).



Standards:

FCC CFR Title 47 Part 15 Subpart B: 2010- Section 15.107 and 15.109
 ANSI C63.4-2009
 Industry Canada Interference-Causing Equipment Standard ICES-003 Issue 5: 2012

Class B

I attest to the accuracy of data and all measurements reported herein were performed by me or were made under my supervision and are correct to the best of my knowledge and belief. I assume full responsibility for the completeness of these measurements and vouch for the qualifications of all persons taking them.

International Standards Laboratory

Jim Chu
 Jim Chu / Director

Lung-Tan LAB:
 No. 120, Lane 180, San Ho Tzuen, Hsin Ho Rd.
 Lung-Tan Hsiang, Tao Yuan County 325, Taiwan
 Tel: 886-3-407-1718; Fax: 886-3-407-1738

