

# R15IT3S-67C3(HB)

## 15" Intel® Core™ i5-1135G7 G-WIN Full IP67 Panel PC



### KEY FEATURES

- 11th Generation (Tiger Lake) Intel® Core™ i5-1135G7 2.4GHz (turbo to 4.2GHz)
- High Quality 15" Panel, 1024 x 768 resolution, 300 nits (Optional for 1000 nits)
- Dust/ Water proof design with VESA mount Full IP67 Panel PC
- Aluminum Die-Casting Housing with Anti-Corrosion Treatments
- Build in ambient Light sensor, Full IP67 Panel PC
- Wide Range 9 to 36V DC Input with isolation. Optional for Ignition On/Off delay
- Optional 6-60V DC Input, and Optional for Ignition On/Off delay
- 5 Wire Resistive Touch / Anti-Reflective Protection Glass (Optional)
- Optional HB/Sunlight Readable up to 1000 nits



### SPECIFICATIONS

#### System Specification

<b>WLAN</b>	Support (Optional)	<b>BT</b>	Support (Optional)
<b>Processor</b>	Intel Core i5-1135G7 2.4GHz (up to 4.2GHz)	<b>Memory</b>	1 x SO-DIMM, DDR4 3200 MHz, 4GB 8GB (Optional) 16GB (Optional) 32GB (Optional)
<b>Storage</b>	1 x M.2 M-Key 2280 NVMe SSD, 128GB 256GB (Optional) 512GB (Optional) 1TB (Optional) 2TB (Optional) 4TB (Optional)	<b>Ethernet controller</b>	2 x Intel® Ethernet Controller
<b>Security</b>	TPM 2.0	<b>Operating System</b>	Windows 11 IoT Enterprise (64 bit) (Optional) Windows 11 Pro 64 bit (Optional) Windows 10 IoT Enterprise (64 bit) (Optional) Linux Ubuntu 22.04 (Optional)

#### Display

<b>Resolution</b>	1024x768	<b>Size</b>	15.0 inches
<b>Contrast Ratio</b>	2000:1	<b>Panel Brightness</b>	300.0 nits
<b>View Angles</b>	88,88,88,88	<b>Active Area</b>	304.1x228.1 mm
<b>Touch / Glass</b>	Resistive Touch Screen Bonding With Panel Protection Glass Without touch function (Optional)	<b>Optional function</b>	High brightness Panel for sunlight readable (Optional)

#### Mechanical

<b>Dimension</b>	398 x 308 x 58 mm	<b>Weight</b>	4.2 kg
<b>Mounting</b>	VESA Mount Yoke Mount	<b>Enclosure</b>	Aluminum Housing
<b>Cooling System</b>	Fanless design		

#### Environment

<b>Operating Humidity</b>	10% to 90% RH, Non-Condensing	<b>Operating Temperature</b>	-10°C to 55°C -40°C to 70°C (with intelligent heater)
<b>Storage Temperature</b>	-30°C to 70°C	<b>Shock</b>	MIL-STD-810G Method 516.6 Procedure I (Optional)

<b>Vibration</b>	MIL-STD-810G Method 514.6 Procedure I	<b>IP rating</b>	IP67
<b>Certification</b>			
<b>Certification</b>	CE, FCC		
<b>IO Ports</b>			
<b>Power Input</b>	1 x M12 waterproof connector for 9~36V DC	<b>USB Port</b>	1 x M12 waterproof connector for 2 x USB2.0
<b>Serial Port</b>	1 x M12 waterproof connector for RS232	<b>LAN</b>	1 x waterproof Giga LAN RJ45 connector
<b>Indicator</b>	1 x LED Indicator for power 1 x LED Indicator for storage		
<b>Control</b>			
<b>Button</b>	1 x Power Button 1 x Reset Button 1 x Lock / Unlock front key function button 1 x Auto Dimming / Manually button 1 x Day / Night Mode button 1 x Brightness Up button 1 x Brightness Down button 1 x LED indicator brightness adjustment button 1 x Light sensor		
<b>Accessory</b>			
<b>Accessory</b>	External open wire Power cable with waterproof connector External USB cable with waterproof connector External COM cable with waterproof connector External LAN cable with waterproof connector Waterproof caps RJ45 female-female converter VESA screws	<b>Optional Accessory</b>	Yoke mount stand (Optional) 100~240V AC to DC Adapter with power cord (Optional)

## DIMENSIONS UNIT:MM

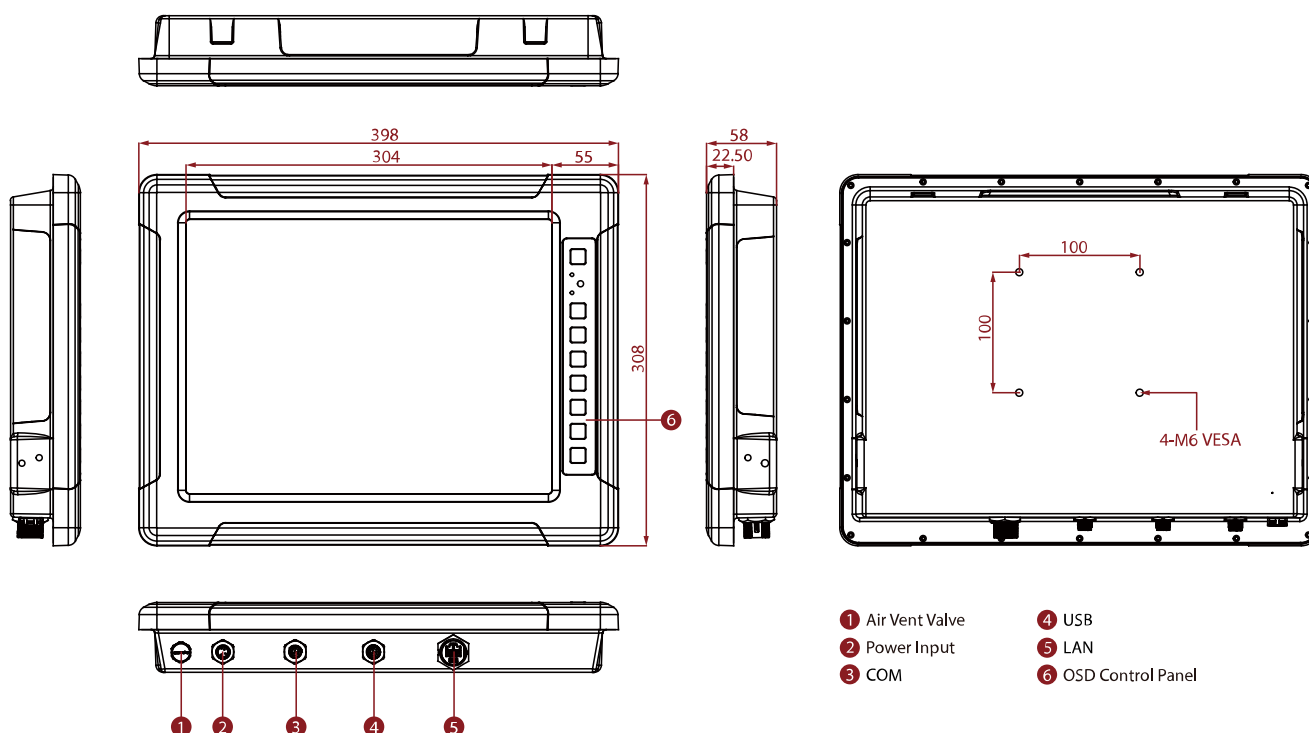

## NOTE

1. This is a simplified drawing and some components are not marked in detail.
2. Weight of the device varies by configuration.
3. Please contact our sales representative if you need further product information.
4. All specifications are subject to change without prior notice.
5. The product shown in this datasheet is a standard model. For diagrams that contain customized or optional I/O, please contact the Winmate Sales Team for more information.

