

# 2.5" SATA SSD

## 3TS6-P Series

**Customer:** \_\_\_\_\_  
**Customer**  
**Part**  
**Number:** \_\_\_\_\_  
**Innodisk**  
**Part**  
**Number:** \_\_\_\_\_  
**Innodisk**  
**Model Name:** \_\_\_\_\_  
**Date:** \_\_\_\_\_

<b>Innodisk Approver</b>	<b>Customer Approver</b>

**Total Solution For  
Industrial Flash Storage**

**Features:**

- SATA III
- Kioxia 3D TLC NAND
- 2.5" SATA SSD
- Standard & Wide-Temperature
- iPowerguard
- iDataguard
- Dynamic Thermal Management

**Performance:**

- Sequential Read up to 510 MB/s
- Sequential Write up to 460 MB/s

**Power Requirements:**

Input Voltage:	5V±5%
Max Operating Wattage:	4.2W
Idle Wattage:	1.7W

**Reliability:**

Capacity	TBW	DWPD
200GB	272	0.82
	634	1.91
400GB	544	0.82
	1269	1.91
800GB	1089	0.82
	2541	1.91
1.6TB	2178	0.82
	5082	1.91
3.2TB	4356	0.82
	10164	1.91

DWPD based on Enterprise workload with 5 years limited warranty.

Data Retentions	10 Years
Warranty	5 Years

For warranty details, please refer to:

[https://www.innodisk.com/en/support\\_and\\_service/warranty](https://www.innodisk.com/en/support_and_service/warranty)

## Table of contents

<b>LIST OF FIGURES .....</b>	<b>7</b>
<b>1. PRODUCT OVERVIEW .....</b>	<b>8</b>
<b>1.1 INTRODUCTION OF INNODISK 2.5" SATA SSD 3TS6-P .....</b>	<b>8</b>
<b>1.2 PRODUCT VIEW AND MODELS .....</b>	<b>8</b>
<b>1.3 SATA INTERFACE.....</b>	<b>9</b>
<b>1.4 2.5-INCH FORM FACTOR .....</b>	<b>9</b>
<b>2. PRODUCT SPECIFICATIONS .....</b>	<b>10</b>
<b>2.1 CAPACITY AND DEVICE PARAMETERS.....</b>	<b>10</b>
<b>2.2 PERFORMANCE .....</b>	<b>10</b>
<b>2.3 ELECTRICAL SPECIFICATIONS .....</b>	<b>13</b>
<b>2.3.1 Power Requirement.....</b>	<b>13</b>
<b>2.3.2 Power Consumption.....</b>	<b>13</b>
<b>2.4 ENVIRONMENTAL SPECIFICATIONS .....</b>	<b>13</b>
<b>2.4.1 Temperature Ranges .....</b>	<b>13</b>
<b>2.4.2 Humidity.....</b>	<b>13</b>
<b>2.4.3 Shock and Vibration .....</b>	<b>13</b>
<b>2.4.4 Mean Time between Failures (MTBF) .....</b>	<b>13</b>
<b>2.5 CE AND FCC COMPATIBILITY .....</b>	<b>14</b>
<b>2.6 RoHS COMPLIANCE .....</b>	<b>14</b>
<b>2.7 RELIABILITY .....</b>	<b>14</b>
<b>2.8 TRANSFER MODE .....</b>	<b>14</b>
<b>2.9 PIN ASSIGNMENT .....</b>	<b>15</b>
<b>2.10 MECHANICAL DIMENSIONS.....</b>	<b>16</b>
<b>2.11 ASSEMBLY WEIGHT .....</b>	<b>16</b>
<b>2.12 SEEK TIME .....</b>	<b>16</b>
<b>2.13 HOT PLUG.....</b>	<b>16</b>
<b>2.14 NAND FLASH MEMORY.....</b>	<b>16</b>
<b>3.1 OVERVIEW.....</b>	<b>17</b>
<b>3.2 SATA CONTROLLER .....</b>	<b>17</b>
<b>3.3 ERROR DETECTION AND CORRECTION.....</b>	<b>17</b>
<b>3.4 WEAR-LEVELING .....</b>	<b>18</b>
<b>3.5 BAD BLOCKS MANAGEMENT .....</b>	<b>18</b>
<b>3.6 iDATA GUARD.....</b>	<b>18</b>
<b>3.7 GARBAGE COLLECTION/TRIM .....</b>	<b>18</b>
<b>3.8 iCELL TECHNOLOGY.....</b>	<b>19</b>
<b>3.9 iPOWER GUARD.....</b>	<b>19</b>
<b>3.10 DIE RAID .....</b>	<b>19</b>

- 3.11 QUICK ERASE (OPTIONAL)..... 19**
  - 3.11.1 Quick Erase Command.....20*
- 3.12 WRITE PROTECT (OPTIONAL)..... 21**
  - 3.12.1 Write Protect Command.....21*
  - 3.12.2 Disable Write Protect Command.....22*
- 4. INSTALLATION REQUIREMENTS .....24**
  - 4.1 2.5" SATA SSD 3TS6-P PIN DIRECTIONS ..... 24**
  - 4.2 ELECTRICAL CONNECTIONS FOR 2.5" SATA SSD 3TS6-P..... 24**
  - 4.3 FORM FACTOR..... 24**
  - 4.4 DEVICE DRIVE ..... 25**
- 5. SMART FEATURE SET .....26**
  - 5.1 SMART ATTRIBUTES..... 27**
- 6. PART NUMBER RULE .....28**

## REVISION HISTORY

Revision	Description	Date
1.0	First Released	June, 2022
1.1	Add Wide-temp. information	Nov., 2022
1.2	Add 112-L 3D TLC (PE cycle:7K) information	Jan., 2023
1.3	Modify SMART Attributes Table	Feb., 2023

## List of Tables

<b>TABLE 1: DEVICE PARAMETERS</b> .....	10
<b>TABLE 2: PERFORMANCE - 112 LAYERS 3D TLC (3,000 P/E CYCLES)</b> .....	10
<b>TABLE 3: PERFORMANCE - 112 LAYERS 3D TLC (7,000 P/E CYCLES)</b> .....	10
<b>TABLE 4: SUSTAIN PERFORMANCE - 112 LAYERS 3D TLC (3,000 P/E CYCLES)</b> .....	11
<b>TABLE 5: SUSTAIN PERFORMANCE - 112 LAYERS 3D TLC (7,000 P/E CYCLES)</b> .....	11
<b>TABLE 6: LATENCY (QD1) - 112 LAYERS 3D TLC (3,000 P/E CYCLES)</b> .....	12
<b>TABLE 7: LATENCY (QD1) - 112 LAYERS 3D TLC (7,000 P/E CYCLES)</b> .....	12
<b>TABLE 8: QUALITY OF SERVICE (QoS)</b> .....	12
<b>TABLE 9: INNODISK 2.5" SATA SSD 3TS6-P POWER REQUIREMENT</b> .....	13
<b>TABLE 10: TYPICAL POWER CONSUMPTION</b> .....	13
<b>TABLE 11: TEMPERATURE RANGE FOR 2.5" SATA SSD 3TS6-P</b> .....	13
<b>TABLE 12: SHOCK/VIBRATION TESTING FOR 2.5" SATA SSD 3TS6-P</b> .....	13
<b>TABLE 13: 2.5" SATA SSD 3TS6-P MTBF</b> .....	14
<b>TABLE 14: INNODISK 2.5" SATA SSD 3TS6-P PIN ASSIGNMENT</b> .....	15
<b>TABLE 15: EXECUTE QUICK ERASE COMMAND FOR INPUTS INFORMATION</b> .....	20
<b>TABLE 16: QUICK ERASE COMMAND FOR NORMAL OUTPUT INFORMATION</b> .....	20

## List of Figures

<b>FIGURE 1: INNODISK 2.5" SATA SSD 3TS6-P</b> .....	8
<b>FIGURE 2: INNODISK 2.5" SATA SSD 3TS6-P BLOCK DIAGRAM</b> .....	17
<b>FIGURE 3: DIAGRAM OF 2.5" SATA SSD WITH ICELL</b> .....	19
<b>FIGURE 4: SIGNAL SEGMENT AND POWER SEGMENT</b> .....	24
<b>FIGURE 5: 2.5" SATA SSD 3TS6-P MECHANICAL SCREW HOLE</b> .....	25

# 1. Product Overview

## 1.1 Introduction of Innodisk 2.5" SATA SSD 3TS6-P

Innodisk 2.5" SATA SSD 3TS6-P products provide high endurance flash memory Solid State Drive (SSD) that can withstand the test of enterprise workload. It supports SATA III standard (6.0GHz) with high performance. Innodisk 2.5" SATA SSD 3TS6-P is designed for industrial field, with optimization of edge server application and supports several standard features, including TRIM, NCQ, and S.M.A.R.T. The SSD have superior performance, no latency time and minimal seek time. It effectively reduces the booting time of operation system, and the power consumption is less than hard disk drive (HDD).

**CAUTION** *TRIM must be enabled.*

*TRIM enables SSD's controller to skip invalid data instead of moving. It can free up significant amount of resources, extends the lifespan of SSD by reducing erase, and write cycles on the SSD. Innodisk's handling of garbage collection along with TRIM command improves write performance on SSDs.*

## 1.2 Product View and Models

Innodisk 2.5" SATA SSD 3TS6-P is available in follow capacities:

2.5" SATA SSD 3TS6-P 200GB

2.5" SATA SSD 3TS6-P 400GB

2.5" SATA SSD 3TS6-P 800GB

2.5" SATA SSD 3TS6-P 1.6TB

2.5" SATA SSD 3TS6-P 3.2TB



**Figure 1: Innodisk 2.5" SATA SSD 3TS6-P**



### **1.3 SATA Interface**

Innodisk 2.5" SATA SSD 3TS6-P supports SATA III interface, and backward compliant with SATA I and SATA II.

### **1.4 2.5-inch Form Factor**

The Industry-standard 2.5-inch form factor design with metal material case is easy for installation, which has a compact design 69.85mm (W) x 100.00mm (L) x 7.00mm (H)

## 2. Product Specifications

### 2.1 Capacity and Device Parameters

2.5" SATA SSD 3TS6-P device parameters are shown in Table 1.

**Table 1: Device parameters**

Capacity	LBA	Cylinders	Heads	Sectors	User Capacity(MB)
200GB	390721968	16383	16	63	190782
400GB	781422768	16383	16	63	381554
800GB	1562824368	16383	16	63	763097
1.6TB	3125627568	16383	16	63	1526185
3.2TB	6251233968	16383	16	63	3052360

### 2.2 Performance

Burst Transfer Rate: 6.0Gbps

**Table 2: Performance - 112 Layers 3D TLC (3,000 P/E cycles)**

Capacity	Unit	200GB	400GB	800GB	1.6TB	3.2TB
Sequential Read (max.)	MB/s	440	510	510	510	450
Sequential Write (max.)		170	340	450	460	430
4KB Random Read (QD32)	IOPS	58,000	70,000	74,000	85,000	82,000
4KB Random Write (QD32)		43,000	56,000	58,000	58,000	57,000

**Table 3: Performance - 112 Layers 3D TLC (7,000 P/E cycles)**

Capacity	Unit	200GB	400GB	800GB	1.6TB	3.2TB
Sequential Read (max.)	MB/s	230	420	510	500	450
Sequential Write (max.)		180	350	450	460	430
4KB Random Read (QD32)	IOPS	51,000	71,000	75,000	85,000	80,000
4KB Random Write (QD32)		43,000	55,000	56,000	59,000	57,000

Note: Performance based on CrystalDiskMark 6.0.2 with file size 1000MB of Queue Depth 32

**Table 4: Sustain Performance - 112 Layers 3D TLC (3,000 P/E cycles)**

Capacity	Unit	200GB	400GB	800GB	1.6TB	3.2TB
Steady Sequential Read	MB/s	420	470	480	480	420
Steady Sequential Write		160	320	440	450	410

Note: Sustain Performance based on Linux FIO Test Result

**Table 5: Sustain Performance - 112 Layers 3D TLC (7,000 P/E cycles)**

Capacity	Unit	200GB	400GB	800GB	1.6TB	3.2TB
Steady Sequential Read	MB/s	220	400	480	480	430
Steady Sequential Write		160	330	420	420	410

Note: Sustain Performance based on Linux FIO Test Result

**Table 6: Latency (QD1) - 112 Layers 3D TLC (3,000 P/E cycles)**

Capacity	Unit	200GB	400GB	800GB	1.6TB	3.2TB
Sequential Read	μs	43	43	46	42	45
Sequential Write		45	47	49	47	48
Random Read		162	160	174	158	174
Random Write		52	51	51	49	51

**Table 7: Latency (QD1) - 112 Layers 3D TLC (7,000 P/E cycles)**

Capacity	Unit	200GB	400GB	800GB	1.6TB	3.2TB
Sequential Read	μs	43	43	44	44	42
Sequential Write		49	49	44	48	47
Random Read		173	185	186	167	182
Random Write		51	49	51	51	49

Note: Latency measured using 4KB(4,096 Bytes) transfer size with Queue Depth equal to 1 on a sequential and random workload

**Table 8: Quality of Service (QoS)**

Capacity	200GB	400GB	800GB	1.6TB	3.2TB
Quality of Service <sup>1,2</sup> (99.9%) (Unit: ms)					
Read Queue Depth 1	0.15	0.16	0.16	0.15	0.16
Write Queue Depth 1	0.05	0.05	0.05	0.05	0.05

Note:

- Quality of Service measured using 4KB (4,096 bytes) transfer size on a random workload on a full Logical Block Address (LBA) span of the drive once the workload has reached steady state but including all background activities required for normal operation and data reliability.
- Based on Random 4KB QD=1 workloads, measured as the time taken for 99.9 percentile of commands to finish the round-trip from host to drive and back to host.

## 2.3 Electrical Specifications

### 2.3.1 Power Requirement

**Table 9: Innodisk 2.5" SATA SSD 3TS6-P Power Requirement**

Item	Symbol	Rating	Unit
Input voltage	V <sub>IN</sub>	+5 DC +- 5%	V

### 2.3.2 Power Consumption

**Table 10: Typical Power Consumption**

Mode	Unit	200GB	400GB	800GB	1.6TB	3.2TB
Read	Watt (W)	2.6	2.8	3.1	3.2	3.3
Write		2.5	3.2	4.1	4.1	4.2
Idle		1.6	1.6	1.6	1.6	1.7
Power-on Peak		3.8	4.8	6.1	6.3	6.2

Note: Current results may vary depending on system components and power circuit design.

Please refer to the test report for other capacities.

## 2.4 Environmental Specifications

### 2.4.1 Temperature Ranges

**Table 11: Temperature range for 2.5" SATA SSD 3TS6-P**

Temperature	Range
Operating	Standard Grade: 0°C to +70°C Industrial Grade: -40°C to +85°C
Storage	-40°C to +85°C

### 2.4.2 Humidity

Relative Humidity: 10-95%, non-condensing

### 2.4.3 Shock and Vibration

**Table 12: Shock/Vibration Testing for 2.5" SATA SSD 3TS6-P**

Reliability	Test Conditions	Reference Standards
Vibration	7 Hz to 2K Hz, 20G, 3 axes	IEC 68-2-6
Mechanical Shock	Duration: 0.5ms, 1500 G, 3 axes	IEC 68-2-27

### 2.4.4 Mean Time between Failures (MTBF)

Table 13 summarizes the MTBF prediction results for various 2.5" SATA SSD 3TS6-P configurations. The analysis was performed using a RAM Commander™ failure rate prediction.

- **Failure Rate:** The total number of failures within an item population, divided by the total

number of life units expended by that population, during a particular measurement interval under stated condition.

- **Mean Time between Failures (MTBF):** A basic measure of reliability for repairable items: The mean number of life units during which all parts of the item perform within their specified limits, during a particular measurement interval under stated conditions.

**Table 13: 2.5" SATA SSD 3TS6-P MTBF**

Product	Condition	MTBF (Hours)
Innodisk 2.5" SATA SSD 3TS6-P	Telcordia SR-332 GB, 25°C	>3,000,000

## 2.5 CE and FCC Compatibility

2.5" SATA SSD 3TS6-P conforms to CE and FCC requirements.

## 2.6 RoHS Compliance

2.5" SATA SSD 3TS6-P is fully compliant with RoHS directive.

## 2.7 Reliability

Parameter	Value	
Flash endurance	3,000 P/E cycles	7,000 P/E cycles
Error Correct Code	Support	
Data Retention	Under 40 °C: 10 Years at Initial NAND status ; 1 Year at NAND Life End	Under 40 °C: 1 Year at Initial NAND status ; 3 Months at NAND Life End
<b>TBW* (Total Bytes Written) Unit:TB</b>		
<b>Capacity</b>	<b>Enterprise workload</b>	
	DWPD: 0.82	DWPD: 1.91
200GB	272	634
400GB	544	1269
800GB	1089	2541
1.6TB	2178	5082
3.2TB	4356	10164
*Note: 1. Based on out-of-box performance. 2. Current TBW Values are for reference only. Actual figures will be released after MP.		

## 2.8 Transfer Mode

2.5" SATA SSD 3TS6-P support following transfer mode:

Serial ATA III 6.0Gbps

Serial ATA II 3.0Gbps

Serial ATA I 1.5Gbps

## 2.9 Pin Assignment

Innodisk 2.5" SATA SSD 3TS6-P uses a standard SATA pin-out. See Table 14 for 2.5" SATA SSD 3TS6-P pin assignment.

**Table 14: Innodisk 2.5" SATA SSD 3TS6-P Pin Assignment**

Name	Type	Description
S1	GND	NA
S2	A+	Differential Signal Pair A
S3	A-	
S4	GND	NA
S5	B-	Differential Signal Pair B
S6	B+	
S7	GND	NA
<b>Key and Spacing separate signal and power segments</b>		
P1	NC	NA
P2	NC	NA
P3	NC	NA
P4	GND	NA
P5	GND	NA
P6	GND	NA
P7	V5	5V Power, Pre-Charge
P8	V5	5V Power
P9	V5	5V Power
P10	GND	NA
P11	DAS/DSS	Device Activity Signal / Disable Staggered
P12	GND	NA
P13	NC	NA
P14	NC	NA
P15	NC	NA

## 2.10 Mechanical Dimensions

DSS25-XXXM71XXAXFP

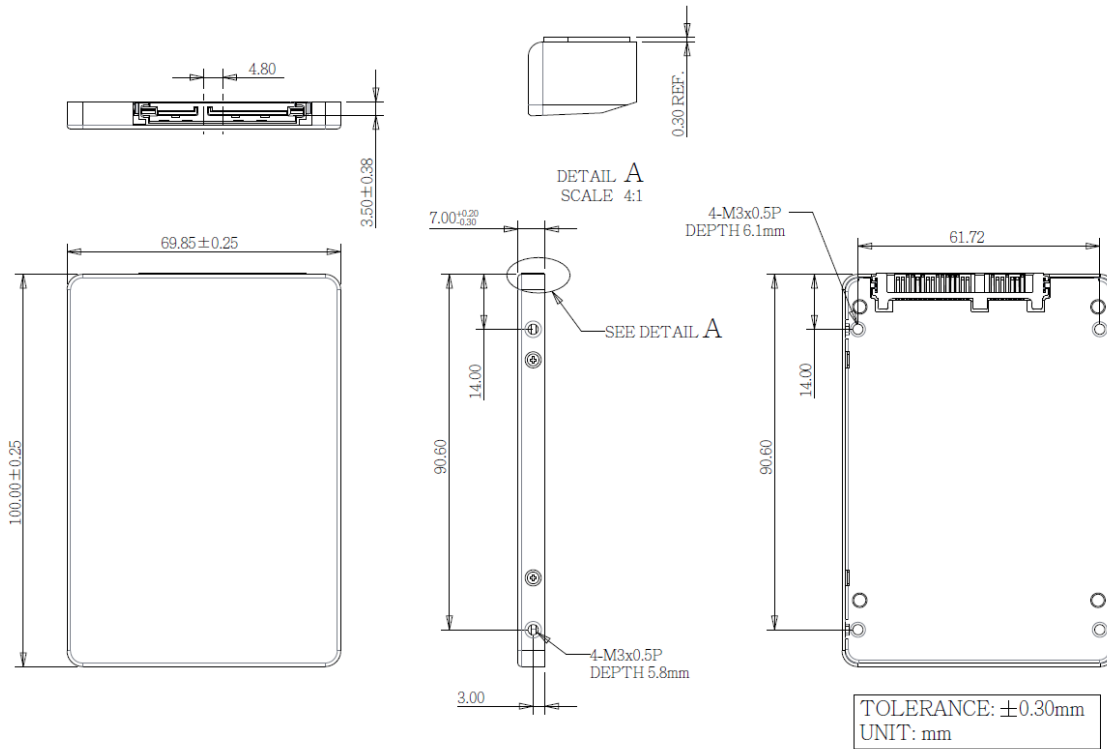

## 2.11 Assembly Weight

An Innodisk 2.5" SATA SSD 3TS6-P within 3D TLC Flash ICs, 1.6TB's weight is 90 grams approx.

## 2.12 Seek Time

Innodisk 2.5" SATA SSD 3TS6-P is not a magnetic rotating design. There is no seek or rotational latency required.

## 2.13 Hot Plug

The SSD support hot plug function and can be removed or plugged-in during operation. User has to avoid hot plugging the SSD which is configured as boot device and installed operation system. Surprise hot plug: The insertion of a SATA device into a backplane (combine signal and power) that has power present. The device powers up and initiates an OOB sequence.

Surprise hot removal: The removal of a SATA device from a powered backplane, without first being placed in a quiescent state.

## 2.14 NAND Flash Memory

Innodisk 2.5" SATA SSD 3TS6-P uses 3D TLC NAND flash memory, with 3,000/7,000 program & erase cycles, which is non-volatility, high reliability and high speed memory storage.



# 3. Theory of Operation

## 3.1 Overview

Figure 2 shows the operation of Innodisk 2.5" SATA SSD 3TS6-P from the system level, including the major hardware blocks.

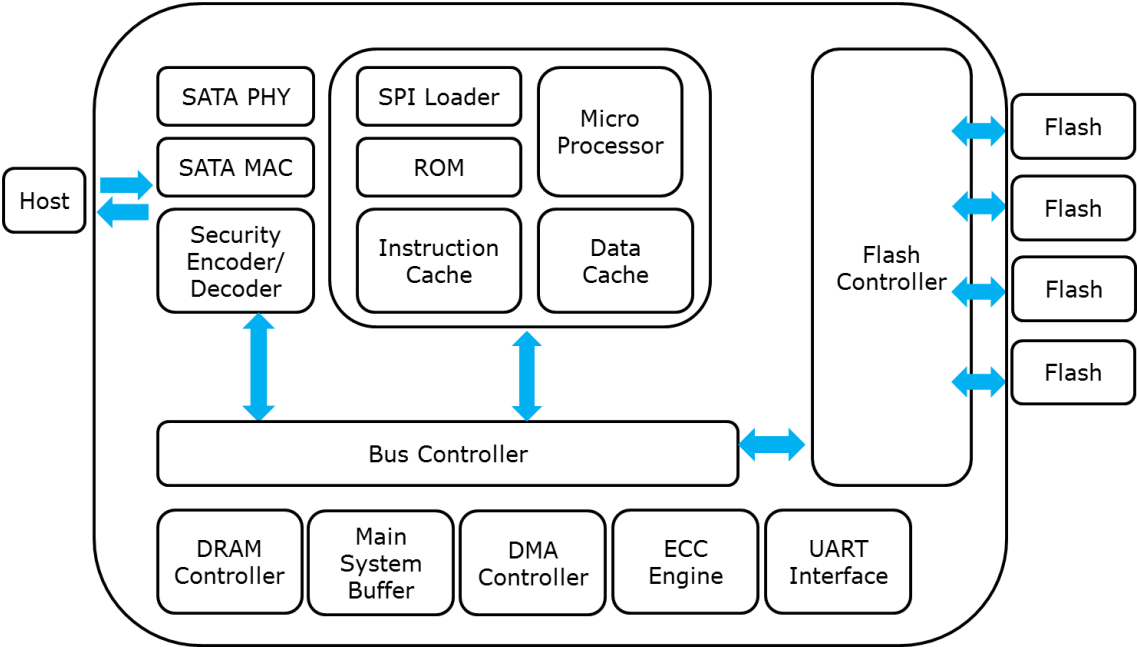

**Figure 2: Innodisk 2.5" SATA SSD 3TS6-P Block Diagram**

Innodisk 2.5" SATA SSD 3TS6-P integrates a SATA III controller and NAND flash memories. Communication with the host occurs through the host interface, using the standard ATA protocol. Communication with the flash device(s) occurs through the flash interface.

\* iCell is optional feature with different part number.

## 3.2 SATA Controller

Innodisk 2.5" SATA SSD 3TS6-P is designed with 88SS1080, a SATA III 6.0Gbps controller, The Serial ATA physical, link and transport layers are compliant with Serial ATA Gen 1, Gen 2 and Gen 3 specification (Gen 3 supports 1.5Gbps/3.0Gbps/6.0Gbps data rate). The controller has 4 channels for flash interface.

## 3.3 Error Detection and Correction

Innodisk 2.5" SATA SSD 3TS6-P is designed with hardware LDPC ECC engine with hard-decision and soft-decision decoding. Low-density parity-check (LDPC) codes have excellent error correcting performance close to the Shannon limit when decoded with the belief-propagation (BP) algorithm using soft-decision information.

### 3.4 Wear-Leveling

Flash memory can be erased within a limited number of times. This number is called the **erase cycle limit** or **write endurance limit** and is defined by the flash array vendor. The erase cycle limit applies to each individual erase block in the flash device.

Innodisk 2.5" SATA SSD 3TS6-P uses a static wear-leveling algorithm to ensure that consecutive writes of a specific sector are not written physically to the same page/block in the flash. This spreads flash media usage evenly across all pages, thereby extending flash lifetime.

### 3.5 Bad Blocks Management

Bad Blocks are blocks that contain one or more invalid bits whose reliability are not guaranteed. The Bad Blocks may be presented while the SSD is shipped, or may develop during the life time of the SSD. When the Bad Blocks is detected, it will be flagged, and not be used anymore. The SSD implement Bad Blocks management, Bad Blocks replacement, Error Correct Code to avoid data error occurred. The functions will be enabled automatically to transfer data from Bad Blocks to spare blocks, and correct error bit.

### 3.6 iData Guard

Innodisk's iData Guard is a comprehensive data protection mechanism that functions before and after a sudden power outage to SSD. Low-power detection terminates data writing before an abnormal power-off, while table-remapping after power-on deletes corrupt data and maintains data integrity. Innodisk's iData Guard provides effective power cycling management, preventing data stored in flash from degrading with use.

### 3.7 Garbage Collection/TRIM

Garbage collection and TRIM technology is used to maintain data consistency and perform continual data cleansing on SSDs. It runs as a background process, freeing up valuable controller resources while sorting good data into available blocks, and deleting bad blocks. It also significantly reduces write operations to the drive, thereby increasing the SSD's speed and lifespan.

### 3.8 iCell Technology

iCell circuit is designed with several capacitors to be able to provide power after host power off. The SSD controller can write all DRAM buffer data to flash, so that is why 2.5" SATA SSD 3TS6-P can ensure all data can be written to disk without any data loss. Once the SSD controller receives this feedback signal, the SSD firmware triggers a mechanism to write the data into flash storage. As a result, iCell is able to provide power during power outage, preventing any data loss from happening.

Note: 8TB capacity doesn't support iCell function.



**Figure 3: Diagram of 2.5" SATA SSD with iCell**

### 3.9 iPower Guard

iPower Guard technology is a set of preventive measures that protect the SSD in an unstable power supply environment. This comprehensive package comprises safeguards for start-up and shut-down to maintain device performance and ensure data integrity.

### 3.10 Die RAID

Die RAID is a controller function which leveraged user capacity to back up the data in NAND flash. Die RAID supported can ensure the user data in the NAND Flash more consistent in certain scenario. Innodisk 2.5" SATA SSD 3TS6-P series is default enable the Die RAID function for the industrial application.

### 3.11 Quick Erase (Optional)

Quick Erase function is designed for emergency data erase in few seconds by providing ATA command.

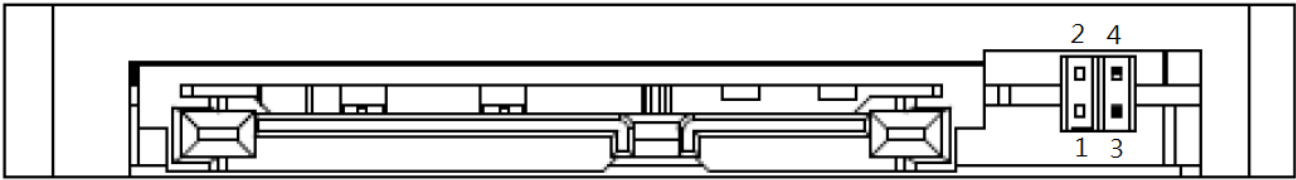

### 3.11.1 Quick Erase Command

- Protocol: No Data

-Inputs

**Table 15: Execute Quick Erase command for inputs information**

Register	7	6	5	4	3	2	1	0
Features	21h							
Sector Count	41h							
LBA Low	Na							
LBA Mid	Na							
LBA High	Na							
Device	1	1	1	0	Na			
Command	82h							

-Normal Outputs

**Table 16: Quick Erase command for normal output information**

Register	7	6	5	4	3	2	1	0
Error	Na							
Sector Count	Na							
LBA Low	Na							
LBA Mid	Na							
LBA High	Na							
Device	obs	Na	obs	DEV	Na	Na	Na	Na
Status	BSY	DRDY	DF	Na	DRQ	Na	Na	ERR

Device register-

**DEV** shall specify the selected device.

Status register

**BSY** will be cleared to zero indicating command completion

**DRDY** will be set to one.

**DF** (Device Fault) will be cleared to zero.

**DRQ** will be cleared to zero

**ERR** will be cleared to zero.

### 3.12 Write Protect (Optional)

Write Protect can be triggered by sending ATA command or shorting GPIO Pins (GPIO Pins optional for certain Part Numbers). When Write Protect function is enabled, ATA write command would be aborted, which can prevent the disk from data modification or data deletion. Write-protected data in disk is read-only, that is, users could not write to it, edit it, append data to it, or delete it. Write Protect pin is set for optional and available for customization (Pin 3/4).

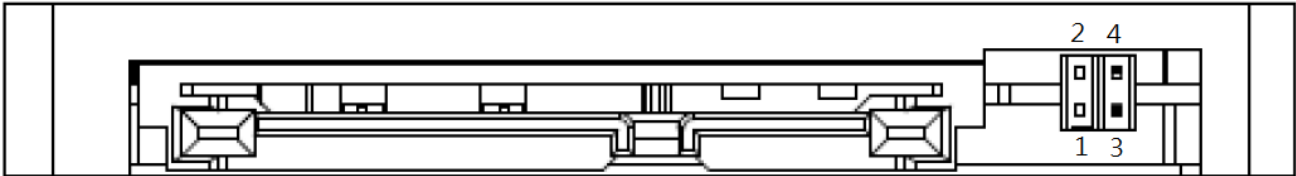

#### 3.12.1 Write Protect Command

This command enable SSD into write protect mode, which is read-only. The SSD under write protect will overpass any write command.

**-Protocol: Non Data Command**

**-Inputs**

##### Execute Enable Write Protect command for inputs information

Register	7	6	5	4	3	2	1	0
Features	17h							
Sector Count	41h							
LBA Low	Na							
LBA Mid	Na							
LBA High	Na							
Device	1	1	1	0	Na			
Command	82h							

**-Normal Outputs**

##### Execute Enable Write Protect command for normal output information

Register	7	6	5	4	3	2	1	0
Error	Na							
Sector Count	Na							
LBA Low	Na							
LBA Mid	Na							
LBA High	Na							
Device	obs	Na	obs	DEV	Na	Na	Na	Na

Status	BSY	DRDY	DF	Na	DRQ	Na	Na	ERR
--------	-----	------	----	----	-----	----	----	-----

Device register-

**DEV** shall specify the selected device.

Status register

**BSY** will be cleared to zero indicating command completion

**DRDY** will be set to one.

**DF** (Device Fault) will be cleared to zero.

**DRQ** will be cleared to zero

**ERR** will be cleared to zero.

### 3.12.2 Disable Write Protect Command

This command disable SSD's write protect feature.

**-Protocol: Non Data Command**

**-Inputs**

**Execute Disable Write Protect command for inputs information**

Register	7	6	5	4	3	2	1	0
Features	18h							
Sector Count	41h							
LBA Low	Na							
LBA Mid	Na							
LBA High	Na							
Device	1	1	1	0	Na			
Command	82h							

**-Normal Outputs**

**Execute Disable Write Protect command for normal output information**

Register	7	6	5	4	3	2	1	0
Error	Na							
Sector Count	Na							
LBA Low	Na							
LBA Mid	Na							
LBA High	Na							
Device	obs	Na	obs	DEV	Na	Na	Na	Na
Status	BSY	DRDY	DF	Na	DRQ	Na	Na	ERR

Device register-

**DEV** shall specify the selected device.

Status register

**BSY** will be cleared to zero indicating command completion

**DRDY** will be set to one.

**DF** (Device Fault) will be cleared to zero.

**DRQ** will be cleared to zero

## 4. Installation Requirements

### 4.1 2.5" SATA SSD 3TS6-P Pin Directions

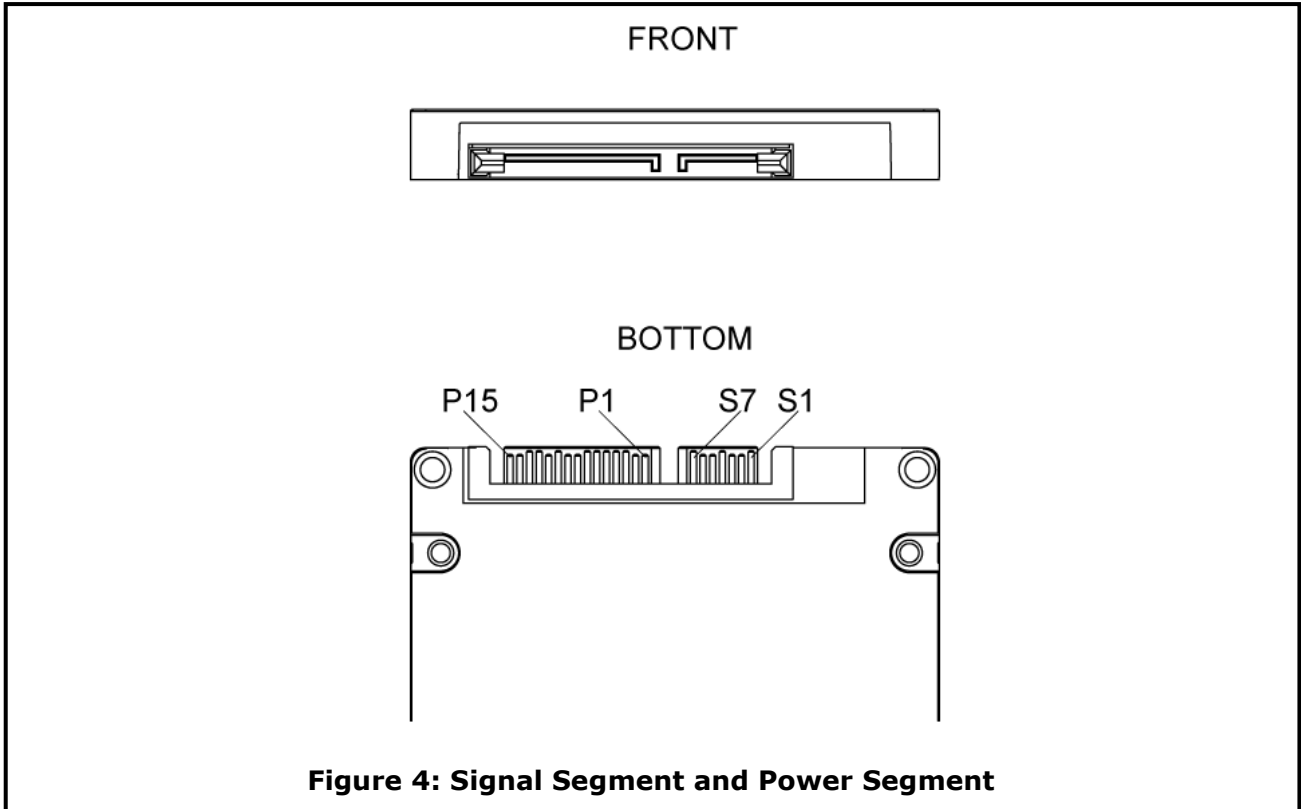

### 4.2 Electrical Connections for 2.5" SATA SSD 3TS6-P

A Serial ATA device may be either directly connected to a host or connected to a host through a cable. For connection via cable, the cable should be no longer than 1 meter. The SATA interface has a separate connector for the power supply. Please refer to the pin description for further details.

### 4.3 Form Factor

Please prepare following things:

- Screw driver.
- Four M3 screws. (Torque value is 2.0 ~ 2.5 Kgf.cm)
- SATA single cable (7-pin, Maximum length 1 meter).
- SATA power cable (15-pin).

Please turn off your computer, and open your computer's case. Find one of available 2.5-inch slot, and plug the SSD in. To use the screws fix the SSD. Plug in the SATA single cable, and power cable. Please boot the installation Operation System from CD-ROM, and install Operation System into SSD.



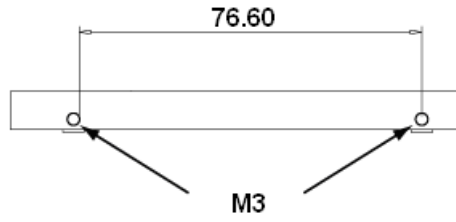

**Figure 5: 2.5" SATA SSD 3TS6-P Mechanical Screw Hole**

#### **4.4 Device Drive**

No additional device drives are required. Innodisk 2.5" SATA SSD 3TS6-P can be configured as a boot device.

## 5. SMART Feature Set

Innodisk 3TS6-P series support the SMART command set and defines some vendor-specific data to report SMART attributes of SSD.

Value	Command
D0h	Read Data
D1h	Read Attribute Threshold
D2h	Enable/Disable Autosave
D3h	Save Attribute Values
D4h	Execute OFF-LINE Immediate
D5h	Read Log
D6h	Return Status
D8h	Enable SMART Operations
D9h	Disable SMART Operations
DAh	Return Status

## 5.1 SMART Attributes

Innodisk 3TS6-P series SMART data attributes are listed in following table.

Attribute ID (hex)	Raw Attribute Value							Attribute Name
	LSB			MSB	00	00	00	
5 (05h)	LSB			MSB	00	00	00	Later Bad
9 (09h)	LSB			MSB	00	00	00	Power-On hours Count
12 (0Ch)	LSB			MSB	00	00	00	Drive Power Cycle Count
163 (A3h)	LSB					MSB	00	Total Bad Block Count
165 (A5h)	LSB			MSB	00	00	00	Max Erase count
167 (A7h)	LSB			MSB	00	00	00	Avg Erase count
169 (A9h)	LSB	00	00	00	00	00	00	Device Life
170 (AAh)	LSB					MSB	00	Spare Block Count
171 (ABh)	LSB					MSB	00	Program fail count
172 (ACh)	LSB					MSB	00	Erase fail count
175(AFh)	LSB	MSB	LSB	MSB	LSB	MSB	00	iCell Health status (Total number of tests/Minutes since last test/last test result(ms))
184 (B8h)	LSB			MSB	00	00	00	Error Corrected Count
187 (BBh)	LSB			MSB	00	00	00	Reported Uncorrect Count
192 (C0h)	LSB			MSB	00	00	00	Unexpected Power Loss Count
194 (C2h)	Cur.*	00	MIN	00	MAX	03	Cur.*	Temperature
229 (E5h)	ID 0	ID 1	ID 2	ID 3	ID 4	ID 5	00	Flash ID
235 (EBh)		MSB	LSB	MSB	LSB	MSB	LSB	Later bad block info (Read/Write/Erase)
241 (F1h)	LSB					MSB	00	Total LBA written(LBA=32MB)
242 (F2h)	LSB					MSB	00	Total LBA read(LBA=32MB)

Cur. \* =Current

## 6. Part Number Rule

CODE	1	2	3	4	5	6	7	8	9	10	11	12	13	14	15	16	17	18	19	20	21
	<b>D</b>	<b>S</b>	<b>S</b>	<b>2</b>	<b>5</b>	<b>-</b>	<b>2</b>	<b>0</b>	<b>0</b>	<b>M</b>	<b>7</b>	<b>1</b>	<b>K</b>	<b>C</b>	<b>A</b>	<b>Q</b>	<b>F</b>	<b>P</b>	<b>-</b>	<b>X</b>	<b>X</b>
Description	Disk	2.5" SATA SSD					Capacity			Category	Flash mode	Operation Temp.	Internal Control	CH.	Flash	icell				Customized Code	
<b>Definition</b>																					
<b>Code 1<sup>st</sup> (Disk)</b>												<b>Code 13<sup>th</sup> (Flash mode)</b>									
D : Disk												K: 112 layers 3D TLC (P/E cycle: 3K)									
<b>Code 2<sup>nd</sup> (Feature Set)</b>												<b>Code 14<sup>th</sup> (Operation Temperature)</b>									
S : Edge Server Series												N: 112 layers 3D TLC (P/E cycle: 7K)									
<b>Code 3<sup>rd</sup> ~5<sup>th</sup> (Form Factor)</b>												<b>Code 15<sup>th</sup> (Internal control)</b>									
S25: 2.5" SSD												C: Standard Grade (0°C~ +70°C)									
												<b>Code 16<sup>th</sup> (Channel of data transfer)</b>									
<b>Code 7<sup>th</sup> ~9<sup>th</sup> (Capacity)</b>												W: Industrial Grade: -40°C to +85°C									
200: 200GB												A-Z: BGA PCB Version									
400: 400GB																					
800: 800GB																					
1T6: 1.6TB												<b>Code 17<sup>th</sup> (Flash Type)</b>									
3T2: 3.2TB												F: Kioxia 3D TLC									
<b>Code 10<sup>th</sup> ~12<sup>th</sup> (Series)</b>												<b>Code 18<sup>th</sup> (iCell)</b>									
M71: SATA 3TS6-P												D: Dual Channels									
												<b>Code 20<sup>th</sup> ~21<sup>th</sup> (Customized code)</b>									
												P: iCell									