

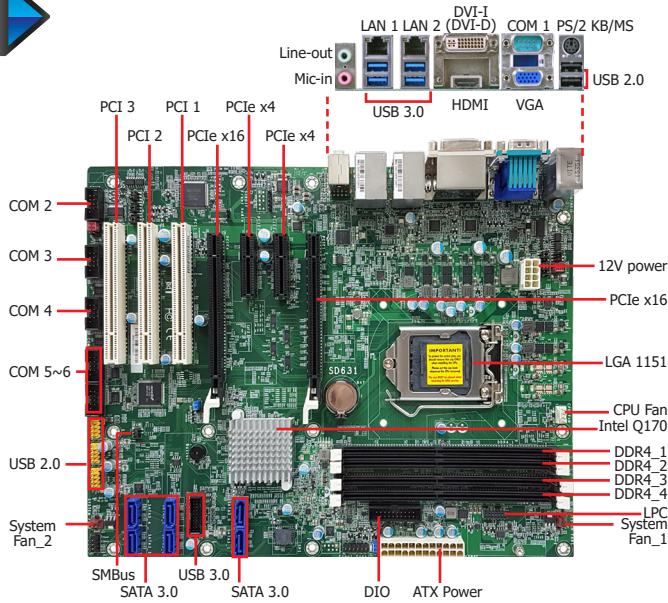

SD631-Q170

Desktop

Q170



Features

- 4 DDR4 DIMM up to 64GB
- 3 independent displays: VGA + DVI-I (DVI-D signal) + HDMI
- HDMI resolution up to 4096x2160 @ 24Hz
- Multiple expansion: 2 PCIe x16 (1 x16 or 2 x8 signal), 2 PCIe x4, 3 PCI, 1 LPC
- Rich I/O: 2 Intel GbE, 6 COM, 6 USB 3.0, 8 USB 2.0
- LPC EXT-RS232/485 module extends additional 4 COM ports



2 Extension Modules for Additional 4 COM Ports (via the LPC connector)



Ordering Information

Model Name	P/N	Memory	GbE	RS-232/422/485	RS-232	USB 3.0	USB 2.0	TPM	Power	Thermal	Temp.
SD631-Q170CRM	770-SD6314-000G	4 DIMM	2	2	4	6	8	N/A	24-pin ATX	Active	0 to 60°C
SD631-Q170CRM	770-SD6314-200G	4 DIMM	2	2	4	6	8	w/ TPM 2.0	24-pin ATX	Active	0 to 60°C

Mechanical Drawing

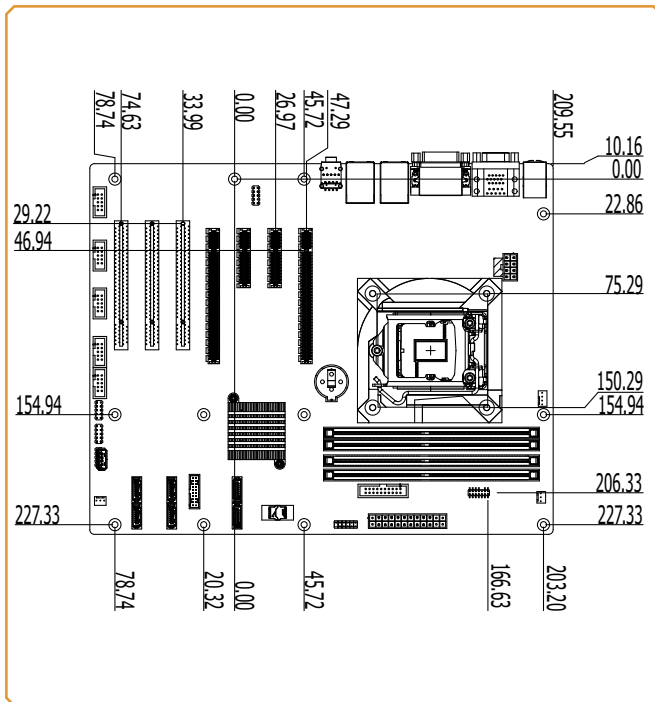

Block Diagram

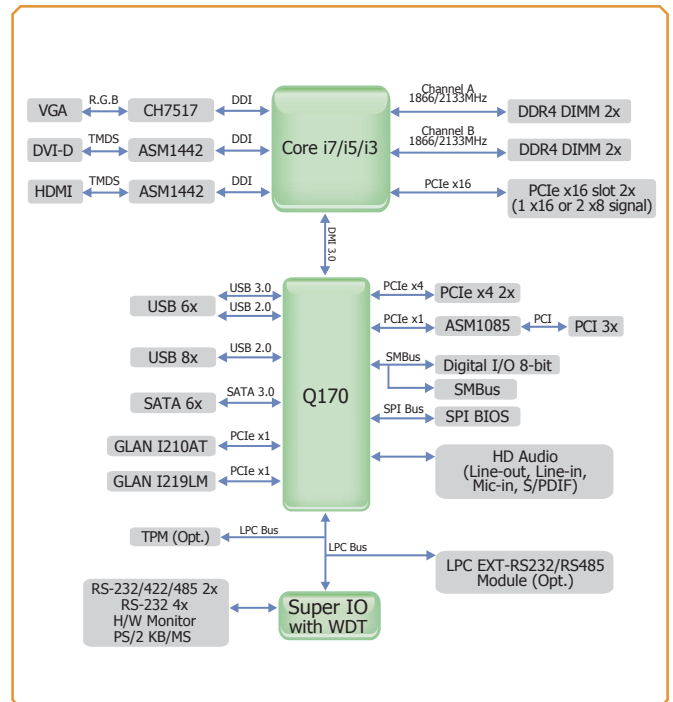

Specifications

SYSTEM	Processor	6th/7th Generation Intel® Core™ /Pentium®/Celeron® LGA 1151 Socket Processors with TDP up to 95W	
	Chipset	Intel® Q170 Chipset	
	Memory	Four 288-pin DIMM up to 64GB	Dual Channel DDR4 2133/2400MHz
	BIOS	Insyde SPI 128Mbit	
GRAPHICS	Controller	Intel® HD Gen 9 Graphics	
	Feature	OpenGL 5.0, DirectX 12, OpenCL 2.1 HW Decode: AVC/H.264, MPEG2, VC1/WMV9, JPEG/MJPEG, HEVC/H265, VP8, VP9 HW Encode: MPEG2, AVC/H264, JPEG, HEVC/H265, VP8, VP9	
	Display	1 x VGA 1 x DVI-I (DVI-D signal) 1 x HDMI	VGA: resolution up to 1920x1200 @ 60Hz DVI-I: resolution up to 1920x1200 @ 60Hz HDMI: resolution up to 4096x2160 @ 24Hz
	Triple Displays	VGA + DVI-I (DVI-D signal) + HDMI	
EXPANSION	Interface	2 x PCIe x16 (1 x16 or 2 x8 signal) (Gen 3) 2 x PCIe x4 (Gen 3) 3 x PCI	
AUDIO	Audio Codec	Realtek ALC888S-VD2-GR	
ETHERNET	Controller	1 x Intel® I210AT PCIe (10/100/1000Mbps) 1 x Intel® I219LM PCIe with iAMT11.0 (10/100/1000Mbps) (only Core i7/i5 supports iAMT)	
REAR I/O	Ethernet	2 x GbE (RJ-45)	
	USB	4 x USB 3.0	2 x USB 2.0
	Serial	1 x RS-232/422/485 (RS-232 w/ power) (DB-9)	
	PS/2	1 x PS/2 (mini-DIN-6)	
	Display	1 x VGA 1 x DVI-I (DVI-D signal) 1 x HDMI	
	Audio	1 x Line-in (opt., MOQ required) 1 x Line-out 1 x Mic-in	
INTERNAL I/O	Serial	1 x RS-232/422/485 (RS-232 w/ power) (2.54mm pitch)	4 x RS-232 (2.54mm pitch)
	USB	2 x USB 3.0 (2.00mm pitch) 6 x USB 2.0 (2.54mm pitch) or 4 x USB 2.0 (2.54mm pitch) + 1 x Vertical USB 2.0 (type A) (opt., MOQ required)	
	Audio	1 x S/PDIF	
	SATA	6 x SATA 3.0 (up to 6Gb/s)	RAID 0/1/5/10
	DIO	1 x 8-bit DIO	
	LPC	1 x LPC (supports LPC EXT-RS232/RS485 module)	
	SMBus	1 x SMBus	
WATCHDOG TIMER	Output & Interval	System Reset, Programmable via Software from 1 to 255 Seconds	
SECURITY	TPM	Infineon TPM2.0/1.2 (opt., MOQ required)	
POWER	Type	ATX	
	Connector	8-pin ATX 12V power	24-pin ATX power
	Consumption	Typical: i7 65W: 12V @ 2.45A (29.44Watt)	Max.: i7 65W: 12V @ 6.02A (72.22Watt)
	RTC Battery	CR2032 Coin Cell	
OS SUPPORT		Windows 7 32/64-bit Windows 8.1 64-bit Windows 10 64-bit Linux Note: 7th Gen CPU SKU ONLY support Windows 10 64-bit & Linux.	
ENVIRONMENT	Temperature	Operating: 0 to 60°C Storage: -30 to 60°C with RTC Battery; -40 to 85°C without RTC Battery	
	Humidity	Operating: 5 to 90% RH	Storage: 5 to 90% RH
	MTBF	368,564 hrs @ 25°C; 210,464hrs @ 45°C; 133,339 hrs @ 60°C Calculation Model: Telcordia Issue 2, Method Case 3 Environment: GB, GC – Ground Benign, Controlled	
MECHANICAL	Dimensions	ATX Form Factor	305mm (12") x 244mm (9.6")
	Height	PCB: 1.6mm	Top Side: 31.47 mm Bottom Side: 4.40 mm
CERTIFICATIONS		CE, FCC Class B, RoHS, UL, KCC	

Packing List

• 1 SD631-Q170 motherboard	
• 1 COM port cables (Length: 400mm, 2 x COM ports)	A81-015012-001G
• 1 Serial ATA data cable (Length: 500mm)	332-553001-005G
• 1 I/O shield	A49-SD6300-001G

Optional Items

• USB 2.0 port cable (Length: 350mm)	A81-001066-016G
• USB 3.0 port cable (Length: 320mm)	A81-001052-023G
• COM port cable (Length: 400mm, 2 x COM ports)	A81-015012-001G
• Serial ATA data cable (Length: 500mm)	332-553001-005G
• Thermal solution (For 35W, Height: 37.3mm)	A71-103004-000G
• Thermal solution (For 65W, Height: 74.47mm)	A71-101158-000G
• Thermal solution (For 95W, Height: 77.2mm)	761-103001-000G
• LPC EXT-RS232 module (4 x RS232 ports)	770-EXTRS1-000G
• LPC EXT-RS485 module (4 x RS485 ports)	770-EXTRS1-100G