

W24IT3S-SPA269-P1

23.8" Intel® Core™ i5 IP69K Stainless P Series Panel PC



KEY FEATURES

- 11th Generation Intel® Core™ i5-1135G7 2.4GHz (up to 4.2GHz)
- Fanless cooling system
- SUS 316 / AISI 316 stainless steel for food and chemical industries
- Full IP69K waterproof enclosure
- A true flat, easy-to-clean front surface with edge-to-edge design
- Waterproof sealed conduit pipe for cable protection
- Support VESA mount, and optional Yoke mount stand
- Support Glove/ Rain mode
- Optical bonding (optional)



SPECIFICATIONS

Display			
Resolution	1920x1080	Size	23.8 inches
Contrast Ratio	3000:1	Panel Brightness	250.0 nits
View Angles	89,89,89,89	Active Area	527.04x296.46 mm
Touch / Glass	Projected Capacitive Multi Touch Screen		
System Specification			
WLAN	Support (Optional)	BT	Support (Optional)
Processor	Intel Core i5-1135G7 2.4GHz (up to 4.2GHz)	Memory	1 x SO-DIMM, DDR4 3200 MHz, 4GB 8GB (Optional) 16GB (Optional) 32GB (Optional)
Storage	1 x M.2 M-Key 2242 SATA SSD or 1 x M.2 M-Key 2280 NVMe SSD 128GB 256GB (Optional) 512GB (Optional) 1TB(for NVMe) (Optional) 2TB(for NVMe) (Optional) 4TB(for NVMe) (Optional) 1 x SATA III , up to 2TB (Optional)	Ethernet controller	2 x Intel® Ethernet Controller
Security	TPM 2.0	Operating System	Windows 11 IoT Enterprise SAC (64 bit) (Optional) Windows 11 Pro 64 bit (Optional) Windows 10 IoT Enterprise (64 bit) (Optional) Linux Ubuntu 22.04 (Optional)
Mechanical			
Dimension	620 x 390 x 56 mm	Mounting	VESA Mount Yoke Mount
Enclosure	Stainless Housing	Cooling System	Fanless design
Environment			
Operating Humidity	10% to 90% RH, Non-Condensing	Operating Temperature	0°C to 45°C
Storage Temperature	-20°C to 60°C	IP rating	IP69K
Certification			
Certification	CE, FCC		

IO Ports			
USB Port	2 x USB3.2 Gen1x1 (Type-A)	Serial Port	1 x RS232/422/485 (Default RS232)
Video	1 x HDMI 1.4	LAN	2 x Giga LAN RJ45 Connector
Indicator	1 x LED Indicator on power button		
Control			
Button	1 x Power Button		
Accessory			
Accessory	1 x Waterproof Conduit 1.5m 1 x Waterproof Conduit 0.3m 2 x Elbow for connect the conduit 1 x AC to DC power adapter with power cord 1 x D-sub9(male) to RJ45 adapter 1 x D-sub9(female) to RJ45 adapter 1 x External RJ45 male to male cable VESAs screws	Optional Accessory	1 x Open wire cable for phoenix connector (Optional) Yoke mount stand kit (Optional)
Power			
Power Rating	12V DC		

DIMENSIONS UNIT:MM

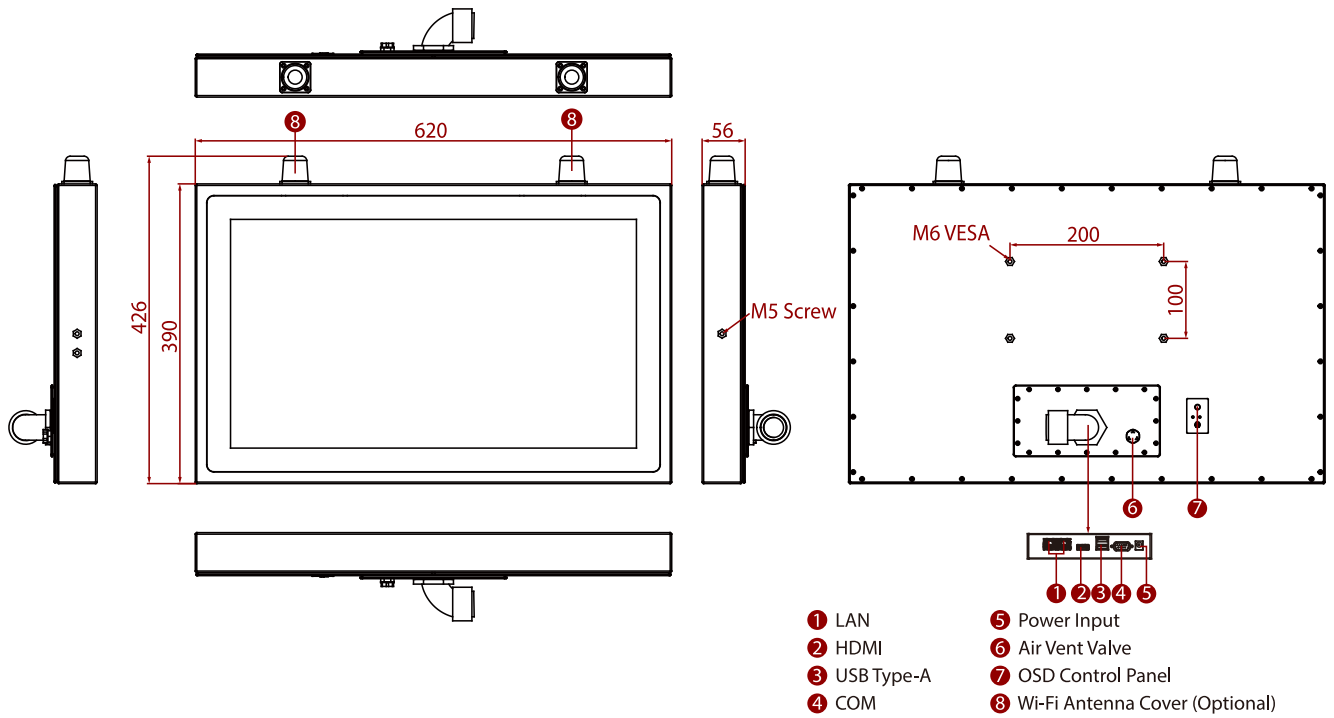

NOTE

1. This is a simplified drawing and some components are not marked in detail.
2. Please contact our sales representative if you need further product information.
3. All specifications are subject to change without prior notice.
4. The product shown in this datasheet is a standard model. For diagrams that contain customized or optional I/O, please contact the Winmate Sales Team for more information.