

Datasheet

SATADOM-MH 3ME3 series

- Best boot drive solution for server and embedded system
- SATA 6Gb/s interface
- High IOPS to reduce boot up timing
- Built-in Pin 7 power supply
- Intelligent error recovery system
- Zero mechanical interference
- Anti-vibration mechanical design
- iSMART disk health monitoring

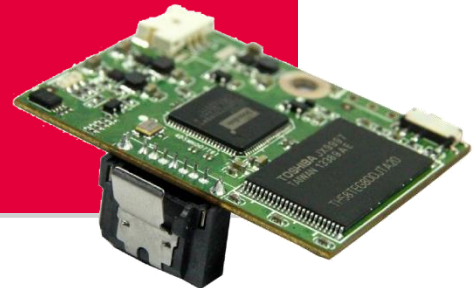

Introduction

Innodisk Serial ATA Disk on Module (SATADOM) supports SATA III standard (6.0Gb/s) interface with excellent performance, and SATADOM-MH 3ME3 is designed as the smallest form factor size that could enhance compatibility with various design applications. Particularly the 7th pin of standard SATA 7pin connector can optionally be the built-in power VCC pin.

Innodisk SATADOM-MH 3ME3 effectively reduces the booting time of operation system and the power consumption is less than hard disk drive (HDD), and complies with ATA protocol, no additional drives are required, and can be configured as a boot device or data storage device.

SATADOM-MH

3ME3 series

Contact us for more information about the SATADOM-MH 3ME3.

Innodisk is a service-driven provider of industrial embedded flash storage products and technologies, with a focus on the cloud computing, industrial/embedded, and aerospace and defense industries.

Diagram

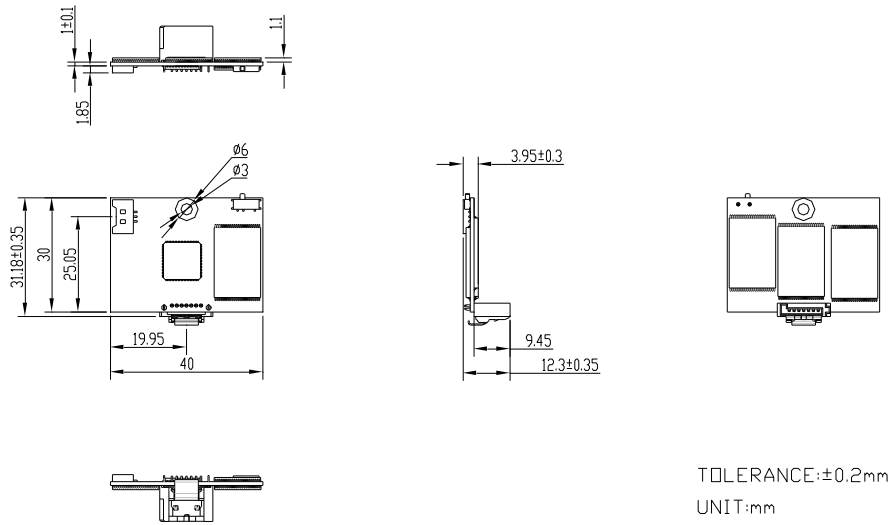

Dimension tolerance: ±0.2mm

Specifications

Headquarters (Taiwan)

5F., No. 237, Sec. 1, Datong Rd.,
Xizhi Dist., New Taipei City,
Taiwan (R.O.C.)
Tel: +886-2-7703-3000
Email: sales@innodisk.com

Branch Offices:

USA
usasales@innodisk.com
+1-510-770-9421
Europe
eusales@innodisk.com
+31-(0)40-282-1818
Japan
jpsales@innodisk.com
+81-3-6667-0161
China
sales_cn@innodisk.com
+86-755-21673689
www.innodisk.com

© 2022 Innodisk Corporation.
All right reserved. Specifications
are subject to change without
prior notice.

Interface	SATA III
Flash Type	MLC
Capacity	8GB~256GB
Max. Channels	2
Sequential R/W (MB/sec, max.)	220/130
Max. Power Consumption	2A (5V x 400mA)
Thermal Sensor	ST- Optional/ WT- Default
External DRAM buffer	-
H/W Write Protect	✓
ATA Security	✓
S.M.A.R.T.	✓
Dimension (WxLxH)	40.0 X 31.18 X 12.3 mm
Environment	Vibration: 20G @7~2000Hz Shock: 1500G @ 0.5ms Storage Temperature: -40°C ~ +85°C MTBF: 3 million hours

20220103

Ordering Information

Operation Temp.	8GB	16GB	32GB	64GB	128GB	256GB
Standard Grade (0°C ~ +70°C)	DESMH-08GD09BC1SC(F)	DESMH-16GD09BC1% C(F)	DESMH-32GD09BC1DC(F)	DESMH-64GD09BC1DC(F)	DESMH-A28D09BC1DC(F)	DESMH-B56D09BC1DC(F)
Industrial Grade (-40°C ~ +85°C)	DESMH-08GD09BW1SC(F)	DESMH-16GD09BW1% C(F)	DESMH-32GD09BW1DC(F)	DESMH-64GD09BW1DC(F)	DESMH-A28D09BW1DC(F)	DESMH-B56D09BW1DC(F)

#: S=Single channel; D=Dual channels

PN end with F is SATADOM Pin 7 with power supply version, which doesn't provide power cable.

innodisk

www.innodisk.com