

SATADOM-MH

3ME3 Series

Customer: _____

Customer

Part Number: _____

Innodisk

Part Number: _____

Innodisk

Model Name: _____

Date: _____

Innodisk Approver	Customer Approver

**Total Solution For
Industrial Flash Storage**

Table of contents

- LIST OF FIGURES6
- 1. PRODUCT OVERVIEW.....7
 - 1.1 INTRODUCTION OF INNODISK SATADOM-MH 3ME37
 - 1.2 PRODUCT VIEW AND MODELS7
 - 1.3 SATA INTERFACE7
- 2. PRODUCT SPECIFICATIONS.....8
 - 2.1 CAPACITY AND DEVICE PARAMETERS8
 - 2.2 PERFORMANCE.....8
 - 2.3 ELECTRICAL SPECIFICATIONS.....8
 - 2.3.1 *Power Requirement*8
 - 2.3.2 *Power Consumption*9
 - 2.4 ENVIRONMENTAL SPECIFICATIONS9
 - 2.4.1 *Temperature Ranges*9
 - 2.4.2 *Humidity*.....9
 - 2.4.3 *Shock and Vibration*9
 - 2.4.4 *Mean Time between Failures (MTBF)*.....9
 - 2.5 CE AND FCC COMPATIBILITY10
 - 2.6 RoHS COMPLIANCE10
 - 2.7 RELIABILITY10
 - 2.8 TRANSFER MODE10
 - 2.9 PIN ASSIGNMENT10
 - 2.10 MECHANICAL DIMENSIONS11
 - 2.11 ASSEMBLY WEIGHT.....11
 - 2.12 SEEK TIME12
 - 2.13 HOT PLUG.....12
 - 2.14 NAND FLASH MEMORY12
- 3. THEORY OF OPERATION.....13
 - 3.1 OVERVIEW.....13
 - 3.2 SATA III CONTROLLER13
 - 3.3 ERROR DETECTION AND CORRECTION14
 - 3.4 WEAR-LEVELING14
 - 3.5 BAD BLOCKS MANAGEMENT14
 - 3.6 POWER CYCLING14
 - 3.7 GARBAGE COLLECTION14
 - 3.8 TRIM15
- 4. INSTALLATION REQUIREMENTS.....15

- 4.1 SATADOM-MH 3ME3 PIN DIRECTIONS..... 15
- 4.2 ELECTRICAL CONNECTIONS FOR SATADOM-MH 3ME3..... 15
- 4.3 DEVICE DRIVE 15
- 4.4 PIN7 VCC 15
- 4.5 WRITE PROTECTION 16
- 4.6 POWER CABLE..... 17

- 5. PART NUMBER RULE18

REVISION HISTORY

Revision	Description	Date
Preliminary	First Released	May, 2015
1.0	Official Released	September, 2015
1.1	Add Toshiba 15nm flash	December, 2015
1.2	Add 16GB 2ch performance Modify power consumption	August, 2016
1.3	Update TRIM/REACH/RoHS	May, 2019

List of Tables

TABLE 1: DEVICE PARAMETERS	8
TABLE 2: PERFORMANCE	8
TABLE 3: INNODISK SATADOM-MH 3ME3 POWER REQUIREMENT	9
TABLE 4: POWER CONSUMPTION	9
TABLE 5: TEMPERATURE RANGE FOR SATADOM-MH 3ME3	9
TABLE 6: SHOCK/VIBRATION TESTING FOR SATADOM-MH 3ME3	9
TABLE 7: SATADOM-MH 3ME3 MTBF	10
TABLE 8: INNODISK SATADOM-MH 3ME3 PIN ASSIGNMENT	11

List of Figures

FIGURE 1: INNODISK SATADOM-MH 3ME3..... 7

FIGURE 2: INNODISK SATADOM-MH 3ME3 BLOCK DIAGRAM 13

FIGURE 3: SIGNAL SEGMENT AND POWER SEGMENT 15

1. Product Overview

1.1 Introduction of Innodisk SATADOM-MH 3ME3

Innodisk Serial ATA Disk on Module (SATADOM) supports SATA III standard (6.0Gb/s) interface with excellent performance, and SATADOM-MH 3ME3 is designed as the smallest form factor size that could enhance compatibility with various design applications. Particularly the 7th pin of standard SATA 7pin connector can optionally be the built-in power VCC pin. In other words, it could be connected directly to the SATA on-board socket on customers' system without additional power cable. Besides, the booting time for operation and the power consumption is less than hard disk drive (HDD), and can work under harsh environment compile with ATA protocol, no additional drives are required, and the SSD can be configured as a boot device or data storage device. Innodisk SATADOM-MH 3ME3 is designed for industrial field, and supports several standard features, including TRIM, NCQ, and S.M.A.R.T. In addition, Innodisk's exclusive industrial-oriented firmware provides a flexible customization service, making it perfect for a variety of industrial applications.

CAUTION TRIM must be enabled.

TRIM enables SSD's controller to skip invalid data instead of moving. It can free up significant amount of resources, extends the lifespan of SSD by reducing erase, and write cycles on the SSD. Innodisk's handling of garbage collection along with TRIM command improves write performance on SSDs.

1.2 Product View and Models

Innodisk SATADOM-MH 3ME3 is available in follow capacities within MLC flash ICs.

[SATADOM-MH 3ME3 08GB](#)

[SATADOM-MH 3ME3 16GB](#)

[SATADOM-MH 3ME3 32GB](#)

[SATADOM-MH 3ME3 64GB](#)

[SATADOM-MH 3ME3 128GB](#)

[SATADOM-MH 3ME3 256GB](#)



Figure 1: Innodisk SATADOM-MH 3ME3

1.3 SATA Interface

Innodisk SATADOM-MH 3ME3 supports SATA III interface, and compliant with SATA I and SATA II.

2. Product Specifications

2.1 Capacity and Device Parameters

SATADOM-MH 3ME3 device parameters are shown in Table 1.

Table 1: Device parameters

Capacity	LBA	Cylinders	Heads	Sectors	User Capacity(MB)
8GB	15649200	15525	16	63	7,641
16GB	31277232	16383	16	63	15,272
32GB	62533296	16383	16	63	30,533
64GB	125045424	16383	16	63	61,057
128GB	250069680	16383	16	63	122,104
256GB	500118192	16383	16	63	244,198

2.2 Performance

Burst Transfer Rate: 6.0Gbps

Table 2: Performance

	Capacity	8GB	16GB		32GB	64GB	128GB	256GB
Toshiba A19nm MLC	Sequential* Read (max.)	100 MB/s	200 MB/s		200 MB/s	200 MB/s	200 MB/s	N/A
	Sequential* Write (max.)	20 MB/s	35 MB/s		70 MB/s	110 MB/s	110 MB/s	
	4KB Random** Read (QD32)	4300 IOPS	6700 IOPS		8100 IOPS	8500 IOPS	8500 IOPS	
	4KB Random** Write (QD32)	5100 IOPS	8500 IOPS		15300 IOPS	21000 IOPS	21000 IOPS	
Toshiba 15nm MLC	Sequential* Read (max.)	100 MB/s	1ch	2ch	200 MB/s	220 MB/s	220 MB/s	220 MB/s
			100 MB/s	200 MB/s				
	Sequential* Write (max.)	20 MB/s	20 MB/s	35 MB/s	40 MB/s	80 MB/s	130 MB/s	130 MB/s
	4KB Random** Read (QD32)	4000 IOP	3800 IOPS	5300 IOPS	5300 IOPS	6900 IOPS	7500 IOPS	8100 IOPS
4KB Random** Write (QD32)	5900 IOPS	5300 IOPS	8000 IOPS	8600 IOPS	15700 IOPS	22000 IOPS	22000 IOPS	

Note: the information is based on CrystalDiskMark 3.01 with file size 1000MB test patent

2.3 Electrical Specifications

2.3.1 Power Requirement

Table 3: Innodisk SATADOM-MH 3ME3 Power Requirement

Item	Symbol	Rating	Unit
Input voltage	V _{IN}	+5 DC +- 5%	V

2.3.2 Power Consumption

Table 4: Power Consumption

Mode	Power Consumption (mA)
Read	239 (max.)
Write	394 (max.)
Idle	93 (max.)
Pin 7 VCC Initial*	1000(max.)

Target: 256GB SATADOM-MH 3ME3

***To design in Pin7/8 VCC on motherboard, 5V with 1A power supply is requested.**

2.4 Environmental Specifications

2.4.1 Temperature Ranges

Table 5: Temperature range for SATADOM-MH 3ME3

Temperature	Range
Operating	Standard Grade: 0°C to +70°C
	Industrial Grade: -40°C to +85°C
Storage	-55°C to +95°C

2.4.2 Humidity

Relative Humidity: 10-95%, non-condensing

2.4.3 Shock and Vibration

Table 6: Shock/Vibration Testing for SATADOM-MH 3ME3

Reliability	Test Conditions	Reference Standards
Vibration	7 Hz to 2K Hz, 20G, 3 axes	IEC 68-2-6
Mechanical Shock	Duration: 0.5ms, 1500 G, 3 axes	IEC 68-2-27

2.4.4 Mean Time between Failures (MTBF)

Table 7 summarizes the MTBF prediction results for various SATADOM-MH 3ME3 configurations. The analysis was performed using a RAM Commander™ failure rate prediction.

- **Failure Rate:** The total number of failures within an item population, divided by the total number of life units expended by that population, during a particular measurement interval under stated condition.

- **Mean Time between Failures (MTBF):** A basic measure of reliability for repairable items: The mean number of life units during which all parts of the item perform within their specified limits, during a particular measurement interval under stated conditions.

Table 7: SATADOM-MH 3ME3 MTBF

Product	Condition	MTBF (Hours)
Innodisk SATADOM-MH 3ME3	Telcordia SR-332 GB, 25°C	>3,000,000

2.5 CE and FCC Compatibility

SATADOM-MH 3ME3 conforms to CE and FCC requirements.

2.6 RoHS Compliance

SATADOM-MH 3ME3 is fully compliant with RoHS directive.

2.7 Reliability

Parameter	Value
Read Cycles	Unlimited Read Cycles
Wear-Leveling Algorithm	Support
Bad Blocks Management	Support
Error Correct Code	Support
iData Guard	Support
Thermal Sensor	WT only
Flash endurance	3,000 P/E cycles
TBW* (Total Bytes Written)	
08GB	2.4
16GB	4.8
32GB	9.6
64GB	19.2
128GB	38.4
256GB	76.8
* Total bytes written is based on JEDEC 218 (Solid-State Drive Requirements and Endurance Test Method)	
** Lifespan is calculated by device written per day	

2.8 Transfer Mode

SATADOM-MH 3ME3 support following transfer mode:

Serial ATA I 1.5Gbps

Serial ATA II 3.0Gbps

Serial ATA III 6.0Gbps

2.9 Pin Assignment

Innodisk SATADOM-MH 3ME3 uses a standard SATA pin-out. See Table 8 for SATADOM-MH 3ME3 pin assignment.

Table 8: Innodisk SATADOM-MH 3ME3 Pin Assignment

Name	Type	Description
Pin 1	GND	Shielding
Pin 2	A+	Differential signal to A
Pin 3	A-	Differential signal to A-
Pin 4	GND	Shielding
Pin 5	B-	Differential signal to B-
Pin 6	B+	Differential signal to B
Pin 7	GND/VCC	Shielding/Power*

⚠ CAUTION
 SATADOM Pin 7 with power supply version (PN end with F) is provided with different model and PN, which request specific M/B designed with 5V power supply through SATA port(7th Pin), and cannot use external cable for power supply!

2.10 Mechanical Dimensions

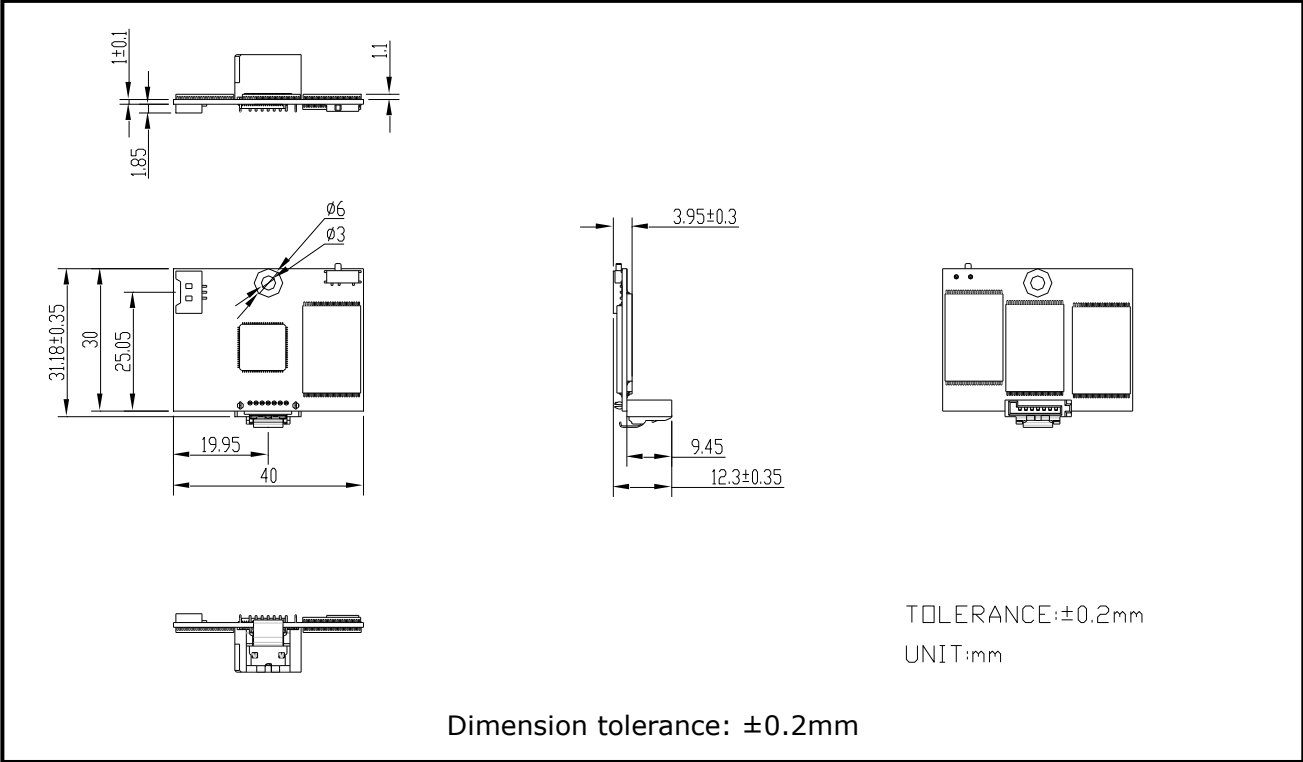

2.11 Assembly Weight

An Innodisk SATADOM-MH 3ME3 within flash ICs, 32GB's weight is 7 grams approximately.

2.12 Seek Time

Innodisk SATADOM-MH 3ME3 is not a magnetic rotating design. There is no seek or rotational latency required.

2.13 Hot Plug

The SSD support hot plug function and can be removed or plugged-in during operation. User has to avoid hot plugging the SSD which is configured as boot device and installed operation system.

Surprise hot plug : The insertion of a SATA device into a backplane (combine signal and power) that has power present. The device powers up and initiates an OOB sequence.

Surprise hot removal: The removal of a SATA device from a powered backplane, without first being placed in a quiescent state.

2.14 NAND Flash Memory

Innodisk SATADOM-MH 3ME3 uses Multi Level Cell (MLC) NAND flash memory, which is non-volatility, high reliability and high speed memory storage. Each cell stores 2 bits or holds four states per cell. Read or Write data to flash memory for SSD is control by microprocessor.

3. Theory of Operation

3.1 Overview

Figure 2 shows the operation of Innodisk SATADOM-MH 3ME3 from the system level, including the major hardware blocks.

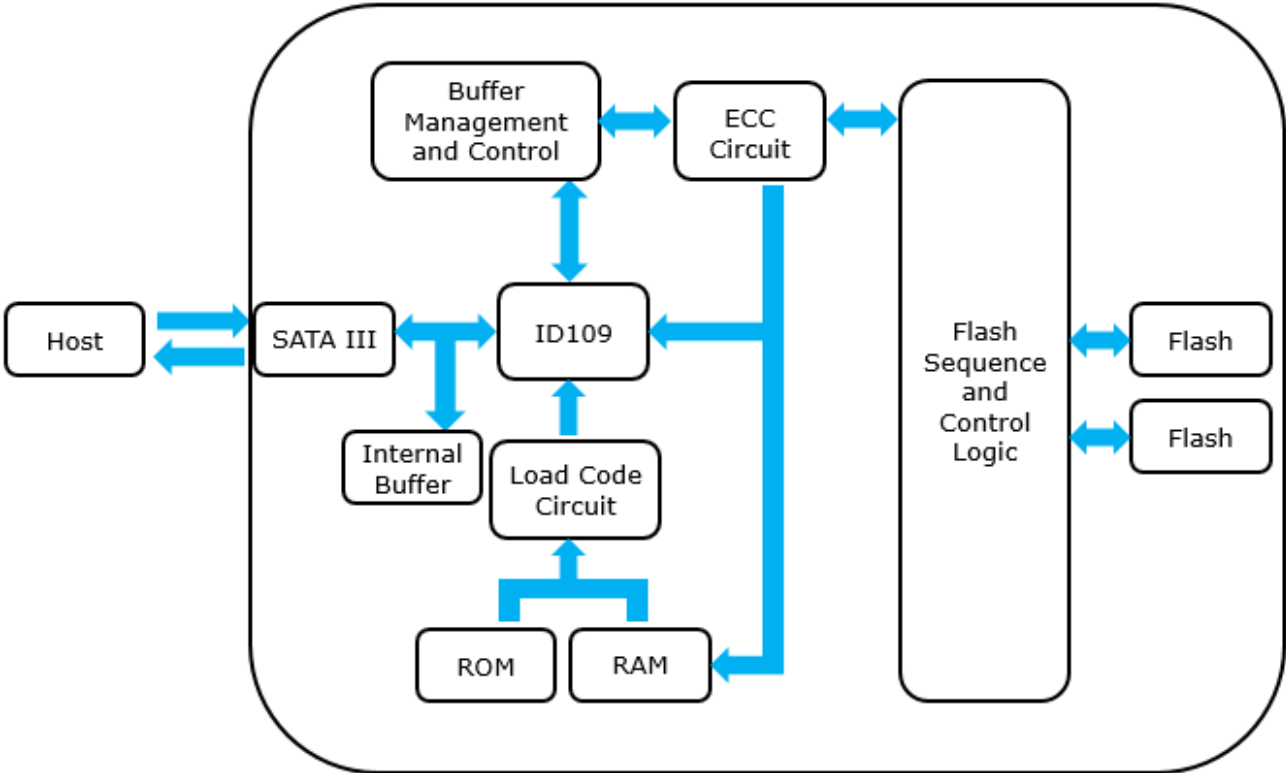

Figure 2: Innodisk SATADOM-MH 3ME3 Block Diagram

Innodisk SATADOM-MH 3ME3 integrates a SATA III controller and NAND flash memories. Communication with the host occurs through the host interface, using the standard ATA protocol. Communication with the flash device(s) occurs through the flash interface.

3.2 SATA III Controller

Innodisk SATADOM-MH 3ME3 is designed with ID 109, a SATA III 6.0Gbps (Gen. 3) controller. The Serial ATA physical, link and transport layers are compliant with Serial ATA Gen 1, Gen 2 and Gen 3 specification (Gen 3 supports 1.5Gbps/3.0Gbps/6.0Gbps data rate). The controller has 2 channels for flash interface.

3.3 Error Detection and Correction

Highly sophisticated Error Correction Code algorithms are implemented. The ECC unit consists of the Parity Unit (parity-byte generation) and the Syndrome Unit (syndrome-byte computation). This unit implements an algorithm that can correct 40 bits per 1024 bytes in an ECC block. Code-byte generation during write operations, as well as error detection during read operation, is implemented on the fly without any speed penalties.

3.4 Wear-Leveling

Flash memory can be erased within a limited number of times. This number is called the **erase cycle limit** or **write endurance limit** and is defined by the flash array vendor. The erase cycle limit applies to each individual erase block in the flash device.

Innodisk SATADOM-MH 3ME3 uses a static wear-leveling algorithm to ensure that consecutive writes of a specific sector are not written physically to the same page/block in the flash. This spreads flash media usage evenly across all pages, thereby extending flash lifetime.

3.5 Bad Blocks Management

Bad Blocks are blocks that contain one or more invalid bits whose reliability are not guaranteed. The Bad Blocks may be presented while the SSD is shipped, or may develop during the life time of the SSD. When the Bad Blocks is detected, it will be flagged, and not be used anymore. The SSD implement Bad Blocks management, Bad Blocks replacement, Error Correct Code to avoid data error occurred. The functions will be enabled automatically to transfer data from Bad Blocks to spare blocks, and correct error bit.

3.6 Power Cycling

Innodisk's power cycling management is a comprehensive data protection mechanism that functions before and after a sudden power outage to SSD. Low-power detection terminates data writing before an abnormal power-off, while table-remapping after power-on deletes corrupt data and maintains data integrity. Innodisk's power cycling provides effective power cycling management, preventing data stored in flash from degrading with use.

3.7 Garbage Collection

Garbage collection is used to maintain data consistency and perform continual data cleansing on SSDs. It runs as a background process, freeing up valuable controller resources while sorting good data into available blocks, and deleting bad blocks. It also significantly reduces write operations to the drive, thereby increasing the SSD's speed and lifespan.

3.8 TRIM

The TRIM command is designed to enable the operating system to notify the SSD which pages no longer contain valid data due to erases either by the user or operating system itself. During a delete operation, the OS will mark the sectors as free for new data and send a TRIM command to the SSD to mark them as not containing valid data. After that the SSD knows not to preserve the contents of the block when writing a page, resulting in less write amplification with fewer writes to the flash, higher write speed, and increased drive life.

4. Installation Requirements

4.1 SATADOM-MH 3ME3 Pin Directions

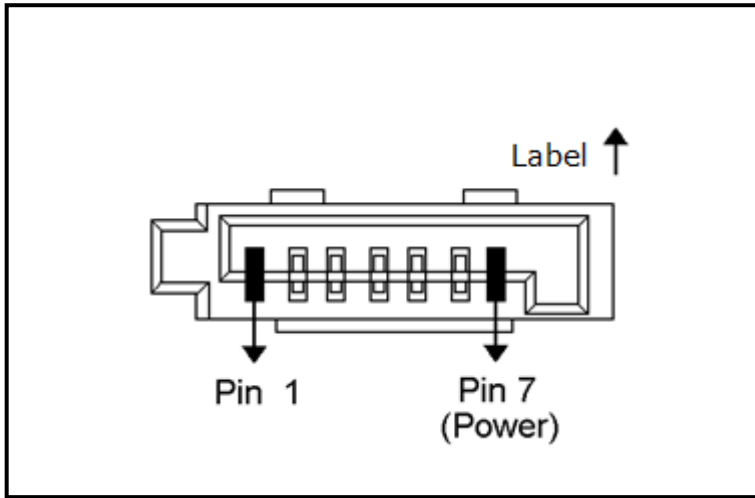

* All SATADOM Pin 7 with power is separate model, with different PN

Figure 3: Signal Segment and Power Segment

4.2 Electrical Connections for SATADOM-MH 3ME3

A Serial ATA device may be either directly connected to a host or connected to a host through a cable. For connection via cable, the cable should be no longer than 1meter. The SATA interface has a separate connector for the power supply. Please refer to the pin description for further details.

4.3 Device Drive

No additional device drives are required. The Innodisk SATADOM-MH 3ME3 can be configured as a boot device.

4.4 Pin7 VCC

SATADOM-MH 3ME3 series with Pin7 VCC, it is defined Pin7 as VCC on the SATA connector. Thus the power would come from SATA connector Pin7 VCC. Customers DO NOT have to use the power cable for power supply. Such a wireless design of SATADOM-MH 3ME3 series with Pin7 VCC brings more convenience to

customers' system. The followings are the points customers have to be careful of while designing in SATADOM-MH 3ME3 series with Pin7 VCC.

SATADOM-MH 3ME3 series with Pin7 VCC is designed with a fuse (poly switch 500mA, 6V) on Pin7's circuit. Such a design could avoid any potential damage to customers' system.

When customers use SATADOM-MH 3ME3 with Pin7 VCC and the host SATA socket does not have power on pin 7, external power must be provided to the SATADOM from the 2pin connector on the side.

To have the advantages of SATADOM-MH 3ME3 series with Pin7 VCC, and to avoid any potential damage to customers' board designed with VCC power supply, Innodisk suggests that customers MUST design their board with a fuse which should be designed before the SATA socket Pin7 VCC. In other words, customers are suggested NOT TO layout 5V VCC to SATA socket on board directly. A circuit diagram example to explain this is shown as below.

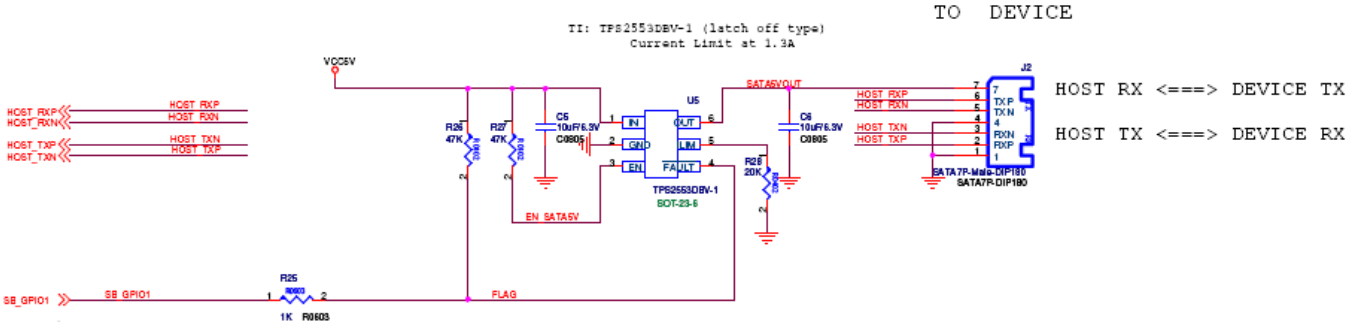

4.5 Write Protection

SATADOM-MH 3ME3 within the write-protect function could prevent the device from modification and deletion. Write-protected data could only be read, that is, users could not write to it, edit it, append data to it, or delete it. When users would like to make sure that neither themselves nor others could modify or destroy the file, users could switch on write-protection. Thus, SATADOM-MH 3ME3 could process write-protect mechanism and disable flash memory to be written-in any data. Only while the system power-off, users could switch on write-protection. Write-protection could not be switched-on, after OS booting.

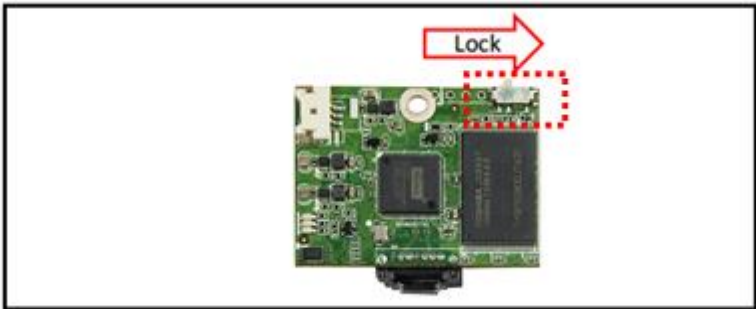

4.6 Power cable

A power cable is shipped with each SATADOM product, which has standard 4pins power connector and special 3 pins power connector for SATADOM. The male and female power connector of SATADOM have foolproof design to avoid misconnection, please check it before power on.

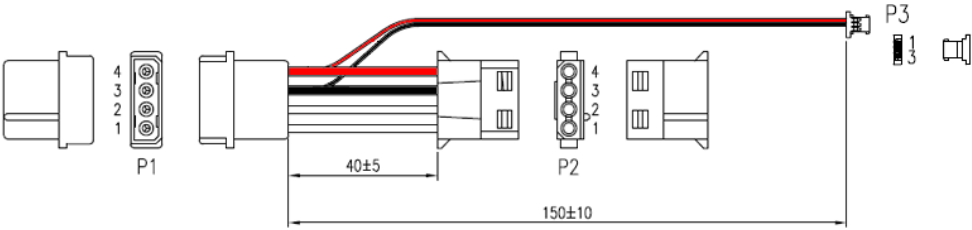

* PN end with F is SATADOM Pin 7 with power supply version, which doesn't provide power cable.

5. Part Number Rule

CODE	1	2	3	4	5	6	7	8	9	10	11	12	13	14	15	16	17	18	19	20	21
	D	E	S	M	H	-	3	2	G	D	0	9	S	C	1	D	C	-	X	X	X
Definition																					
Code 1st (Disk)											Code 14th (Operation Temperature)										
D : Disk											C: Standard Grade (0°C ~ +70°C)										
Code 2nd (Feature set)											Code 15th (Internal control)										
E : Embedded series											W: Industrial Grade (-40°C ~ +85°C)										
Code 3rd ~5th (Form factor)											Code 16th (Channel of data transfer)										
SMH: SATADOM-MH											1~9: TSOP PCB version.										
Code 7th ~9th (Capacity)											Code 17th (Flash Type)										
08G:8GB 16G:16GB 32G: 32GB 64G:64GB											S: Single Channel										
A28: 128GB B56:256GB											D: Dual Channels										
Code 10th ~12th (Controller)											Code 18th (pin7 type)										
D09: ID109											C: Toshiba MLC										
Code 13th (Flash mode)											Code 19th~21st (Customize code)										
S: Synchronous flash (Toshiba A19nm)											F: Pin7 version (Optional)										
B: Synchronous flash (Toshiba 15nm)																					

Appendix

CE/FCC

Certificate

Issue Date: July 29, 2015
Ref. Report No. ISL-15LE318CE

Product Name : SATADOM-MH
Model(s) : SATADOM-MH 3\$*#-&
(\$:Flash type: (S:SLC,I:iSLC,M:MLC);
*:Product line: (E:Embedded, G:EverGreen, R:InnoRobust);
#:Controller: (empty:106/107/167/170, 2:201/ 202, 3:108/109);
&:Product feature: (P:with DRAM, empty:without DRAM))
Responsible Party : Innodisk Corporation
Address : 5F.No.237, Sec. 1, Datong Rd., Xizhi Dist., New Taipei City 221,
Taiwan (R.O.C.)

We, **International Standards Laboratory**, hereby certify that:

The device bearing the trade name and model specified above has been shown to comply with the applicable technical standards as indicated in the measurement report and was tested in accordance with the measurement procedures specified in European Council Directive- EMC Directive 2004/108/EC. The device was passed the test performed according to :



Standards:

EN 55022: 2010+AC2011 and CISPR 22: 2008 (modified)
EN 61000-3-2: 2006+A1:2009 +A2:2009 and IEC 61000-3-2: 2005+A1:2008 +A2:2009
EN 61000-3-3: 2013 and IEC 61000-3-3: 2013
EN 55024: 2010 and CISPR 24: 2010
EN 61000-4-2: 2009 and IEC 61000-4-2: 2008
EN 61000-4-3: 2006+A1: 2008 +A2: 2010 and
IEC 61000-4-3:2006+A1: 2007+A2: 2010
EN 61000-4-4:2012 and IEC 61000-4-4:2012

I attest to the accuracy of data and all measurements reported herein were performed by me or were made under my supervision and are correct to the best of my knowledge and belief. I assume full responsibility for the completeness of these measurements and vouch for the qualifications of all persons taking them.

International Standards Laboratory

Jim Chu
Jim Chu / Director

Hsi-Chih LAB:

No. 65, Gu Dai Keng Street, Hsi-Chih Dist.,
New Taipei City 221, Taiwan
Tel: 886-2-2646-2550; Fax: 886-2-2646-4641

Lung-Tan LAB:

No. 120, Lane 180, Hsin Ho Rd., Lung-Tan Dist.,
Tao Yuan City 325, Taiwan
Tel: 886-3-407-1718; Fax: 886-3-407-1738



Certificate

Issue Date: July 29, 2015
Ref. Report No. ISL-15LE318FB

Product Name : SATADOM-MH
Model(s) : SATADOM-MH 3\$*#-&
(\$:Flash type: (S:SLC,I:iSLC,M:MLC);
*:Product line: (E:Embedded, G:EverGreen, R:InnoRobust);
#:Controller: (empty:106/107/167/170, 2:201/ 202, 3:108/109);
&:Product feature: (P:with DRAM, empty:without DRAM))
Applicant : Innodisk Corporation
Address : 5F.No.237, Sec. 1, Datong Rd., Xizhi Dist., New Taipei City 221,
Taiwan (R.O.C.)

We, **International Standards Laboratory**, hereby certify that:

The device bearing the trade name and model specified above has been shown to comply with the applicable technical standards as indicated in the measurement report and was tested in accordance with the measurement procedures specified. (refer to Test Report if any modifications were made for compliance).



Standards:

FCC CFR Title 47 Part 15 Subpart B: 2014- Section 15.107 and 15.109
ANSI C63.4-2009
Industry Canada Interference-Causing Equipment Standard ICES-003 Issue 5: 2012

Class B

I attest to the accuracy of data and all measurements reported herein were performed by me or were made under my supervision and are correct to the best of my knowledge and belief. I assume full responsibility for the completeness of these measurements and vouch for the qualifications of all persons taking them.

International Standards Laboratory

Jim Chu
Jim Chu / Director

Hsi-Chih LAB:

No. 65, Gu Dai Keng Street, Hsi-Chih Dist.,
New Taipei City 221, Taiwan
Tel: 886-2-2646-2550; Fax: 886-2-2646-4641



Lung-Tan LAB:

No. 120, Lane 180, Hsin Ho Rd., Lung-Tan Dist.,
Tao Yuan City 325, Taiwan
Tel: 886-3-407-1718; Fax: 886-3407-1738



innodisk

宜鼎國際股份有限公司
Innodisk Corporation
REACH Declaration

Tel:(02)7703-3000 Fax:(02) 7703-3555 Internet: <http://www.innodisk.com/>

We hereby confirm that the product(s) delivered to

Innodisk P/N	Description
All Innodisk EM FLASH Products	

- contain(s) **no** hazardous substances or constituents exceeding the defined threshold 0.1 % by weight in homogenous material if not otherwise specified, as described in the candidate list table currently including 201 substances and shown on the ECHA website (<http://echa.europa.eu/de/candidate-list-table>).
- contain(s) one or more hazardous substances or constituents exceeding 0.1 % by weight in homogenous material if not otherwise specified in candidate list table. Where the threshold value is exceeded, the substances in question are to be declared in accompanying Appendix A.
- Comply with REACH Annex XVII.

Guarantor

Company name 公司名稱：Innodisk Corporation 宜鼎國際股份有限公司

Company Representative 公司代表人：Randy Chien 簡川勝

Company Representative Title 公司代表人職稱：Chairman 董事長

Date 日期：2019 / 07 / 24

宜鼎國際股份有限公司
Innodisk Corporation

Tel:(02)7703-3000 Fax:(02) 7703-3555 Internet: <http://www.innodisk.com/>

RoHS 自我宣告書 (RoHS Declaration of Conformity)

Manufacturer Product: All Innodisk EM Flash and Dram products

- 一、 宜鼎國際股份有限公司（以下稱本公司）特此保證售予貴公司之所有產品，皆符合歐盟 2011/65/EU 及 (EU) 2015/863 關於 RoHS 之規範要求。
Innodisk Corporation declares that all products sold to the company, are complied with European Union RoHS Directive (2011/65/EU) and (EU) 2015/863 requirement.
- 二、 本公司同意因本保證書或與本保證書相關事宜有所爭議時，雙方宜友好協商，達成協議。
Innodisk Corporation agrees that both parties shall settle any dispute arising from or in connection with this Declaration of Conformity by friendly negotiations.
- 三、 本公司聲明我們的產品符合 RoHS 指令的附件中 (7a)、(7c-1) 允許豁免。
We declare, our products permitted by the following exemptions specified in the Annex of the RoHS directive.
- ※ (7a) Lead in high melting temperature type solders (i. e. lead-based alloys containing 85% by weight or more lead).
- ※ (7C-1) Electrical and electronic components containing lead in a glass or ceramic other than dielectric ceramic in capacitors, e.g. piezoelectric devices, or in a glass or ceramic matrix compound.

Name of hazardous substance	Limited of RoHS ppm (mg/kg)
鉛 (Pb)	< 1000 ppm
汞 (Hg)	< 1000 ppm
鎘 (Cd)	< 100 ppm
六價鉻 (Cr 6+)	< 1000 ppm
多溴聯苯 (PBBs)	< 1000 ppm
多溴二苯醚 (PBDEs)	< 1000 ppm
鄰苯二甲酸二(2-乙基己基)酯 (DEHP)	< 1000 ppm
鄰苯二甲酸丁酯苯甲酯 (BBP)	< 1000 ppm
鄰苯二甲酸二丁酯 (DBP)	< 1000 ppm
鄰苯二甲酸二異丁酯 (DIBP)	< 1000 ppm

立 保 證 書 人 (Guarantor)

Company name 公司名稱： Innodisk Corporation 宜鼎國際股份有限公司

Company Representative 公司代表人： Randy Chien 簡川勝

宜鼎國際股份有限公司
Innodisk Corporation

Company Representative Title 公司代表人職稱：Chairman 董事長

Date 日期：2018 / 07 / 01

