

M.2 (S42)

3MG2-P Series

Customer: _____

Customer

Part

Number: _____

Innodisk

Part

Number: _____

Innodisk

Model Name: _____

Date: _____

Innodisk Approver	Customer Approver

**Total Solution For
Industrial Flash Storage**

Table of contents

LIST OF TABLES	5
LIST OF FIGURES	6
1. PRODUCT OVERVIEW	7
1.1 INTRODUCTION OF INNODISK M.2 (S42) 3MG2-P	7
1.2 PRODUCT VIEW AND MODELS	7
1.3 SATA INTERFACE	7
2. PRODUCT SPECIFICATIONS	8
2.1 CAPACITY AND DEVICE PARAMETERS	8
2.2 PERFORMANCE	8
2.3 ELECTRICAL SPECIFICATIONS	8
2.3.1 Power Requirement	8
2.3.2 Power Consumption	9
2.4 ENVIRONMENTAL SPECIFICATIONS	9
2.4.1 Temperature Ranges	9
2.4.2 Humidity	9
2.4.3 Shock and Vibration	9
2.4.4 Mean Time between Failures (MTBF)	9
2.5 CE AND FCC COMPATIBILITY	10
2.6 RoHS COMPLIANCE	10
2.8 TRANSFER MODE	10
2.9 PIN ASSIGNMENT	11
2.11 ASSEMBLY WEIGHT	13
2.12 SEEK TIME	13
2.13 HOT PLUG	13
2.14 NAND FLASH MEMORY	13
3. THEORY OF OPERATION	14
3.1 OVERVIEW	14
3.2 SATA III CONTROLLER	14
3.3 ERROR DETECTION AND CORRECTION	15
3.4 WEAR-LEVELING	15
3.5 BAD BLOCKS MANAGEMENT	15
3.6 iDATA GUARD	15
3.7 GARBAGE COLLECTION/TRIM	15
4. INSTALLATION REQUIREMENTS	16
4.1 M.2 (S42) 3MG2-P PIN DIRECTIONS	16
4.2 ELECTRICAL CONNECTIONS FOR M.2 (S42) 3MG2-P	16

- 4.3 DEVICE DRIVE 16**
- 5. SMART FEATURE SET17**
 - 5.1 SMART ATTRIBUTES..... 17**
- 5. PART NUMBER RULE19**

REVISION HISTORY

Revision	Description	Date
Rev 1.0	Official released	Nov., 2016
Rev 1.1	Update performance/TBW Modify pin assignment	Apr., 2017
Rev 1.2	Add 256Gb TBW Update REACH/RoHS/CE/FCC certificate	Aug., 2017
Rev 1.3	Modify power consumption Update Mechanical drawing	Apr., 2018

List of Tables

- TABLE 1: DEVICE PARAMETERS.....8**
- TABLE 2: PERFORMANCE8**
- TABLE 3: INNODISK M.2 (S42) 3MG2-P POWER REQUIREMENT8**
- TABLE 4: POWER CONSUMPTION9**
- TABLE 5: TEMPERATURE RANGE FOR M.2 (S42) 3MG2-P9**
- TABLE 6: SHOCK/VIBRATION TESTING FOR M.2 (S42) 3MG2-P9**
- TABLE 7: M.2 (S42) 3MG2-P MTBF10**
- TABLE 8: INNODISK M.2 (S42) 3MG2-P PIN ASSIGNMENT11**
- TABLE 9: SMART COMMAND17**
- TABLE 10: SMART ATTRIBUTE17**

List of Figures

FIGURE 1: INNODISK M.2 (S42) 3MG2-P (TYPE 2242).....7
FIGURE 2: INNODISK M.2 (S42) 3MG2-P BLOCK DIAGRAM.....14
FIGURE 3: SIGNAL SEGMENT AND POWER SEGMENT.....16

1. Product Overview

1.1 Introduction of Innodisk M.2 (S42) 3MG2-P

Innodisk M.2 (S42) 3MG2-P is designed as the standard M.2 form factor with SATA interface, and supports SATA III standard (6.0Gb/s) with excellent performance. The form factor refers to the M.2(NGFF) specification which established by JEDEC. Regarding of mechanical interference, Innodisk M.2 (S42) 3MG2-P absolutely replaces the traditional hard disk and makes personal computer, in any field, smaller and easier.

Innodisk M.2 (S42) 3MG2-P effectively reduces the booting time of operation system and the power consumption is less than hard disk drive (HDD), and complies with ATA protocol, no additional drives are required, and can be configured as a boot device or data storage device

1.2 Product View and Models

Innodisk M.2 (S42) 3MG2-P is available in following capacities within MLC flash ICs.

[M.2 \(S42\) 3MG2-P 32GB \(type 2242\)](#)

[M.2 \(S42\) 3MG2-P 64GB \(type 2242\)](#)

[M.2 \(S42\) 3MG2-P 128GB \(type 2242\)](#)

[M.2 \(S42\) 3MG2-P 256GB \(type 2242\)](#)



Figure 1: Innodisk M.2 (S42) 3MG2-P (type 2242)

1.3 SATA Interface

Innodisk M.2 (S42) 3MG2-P supports SATA III interface, and compliant with SATA I and SATA II. SATA III interface can work with Serial Attached SCSI (SAS) host system, which is used in server computer. Innodisk M.2 (S42) 3MG2-P is compliant with Serial ATA Gen 1, Gen 2 and Gen 3 specification (Gen 3 supports 1.5Gbps /3.0Gbps/6.0Gbps data rate).

2. Product Specifications

2.1 Capacity and Device Parameters

M.2 (S42) 3MG2-P device parameters are shown in Table 1.

Table 1: Device parameters

Capacity	Cylinders	Heads	Sectors	LBA	user space
32GB	16383	16	63	60579792	29,580
64GB	16383	16	63	121138416	59,150
128GB	16383	16	63	242255664	118,289
256GB	16383	16	63	484490160	236,567

2.2 Performance

Burst Transfer Rate: 6.0Gbps

Table 2: Performance

Capacity	32GB	64GB	128GB	256GB
Sequential* Read (QD32)	280 MB/s	550 MB/s	560 MB/s	560 MB/s
Sequential* Write (QD32)	45 MB/s	90 MB/s	180 MB/s	360 MB/s
4KB Random* Read (QD32)	27,000 IOPS	51,000 IOPS	51,000 IOPS	51,000 IOPS
4KB Random* Write (QD32)	12,000 IOPS	23,000 IOPS	46,000 IOPS	51,000 IOPS

Note: the information is based on CrystalDiskMark 5.1.2 with file size 1000MB test pattern

2.3 Electrical Specifications

2.3.1 Power Requirement

Table 3: Innodisk M.2 (S42) 3MG2-P Power Requirement

Item	Symbol	Rating	Unit
Input voltage	V _{IN}	+3.3 DC +- 5%	V

2.3.2 Power Consumption

Table 4: Power Consumption

Mode	Power Consumption (mA)
Read	382 (max.)
Write	788 (max.)
Idle	123 (max.)

* Target: 256GB M.2 (S42) 3MG2-P

2.4 Environmental Specifications

2.4.1 Temperature Ranges

Table 5: Temperature range for M.2 (S42) 3MG2-P

Temperature	Range
Operating	Standard Grade: 0°C to +70°C
	Industrial Grade: -40°C to +85°C
Storage	-55°C to +95°C

2.4.2 Humidity

Relative Humidity: 10-95%, non-condensing

2.4.3 Shock and Vibration

Table 6: Shock/Vibration Testing for M.2 (S42) 3MG2-P

Reliability	Test Conditions	Reference Standards
Vibration	7 Hz to 2K Hz, 20G, 3 axes	IEC 68-2-6
Mechanical Shock	Duration: 0.5ms, 1500 G, 3 axes	IEC 68-2-27

2.4.4 Mean Time between Failures (MTBF)

Table 7 summarizes the MTBF prediction results for various M.2 (S42) 3MG2-P configurations. The analysis was performed using a RAM Commander™ failure rate prediction.

- **Failure Rate:** The total number of failures within an item population, divided by the total number of life units expended by that population, during a particular measurement interval under stated condition.
- **Mean Time between Failures (MTBF):** A basic measure of reliability for repairable items: The mean number of life units during which all parts of the item perform within their specified limits, during a particular measurement interval under stated conditions.

Table 7: M.2 (S42) 3MG2-P MTBF

Product	Condition	MTBF (Hours)
Innodisk M.2 (S42) 3MG2-P	Telcordia SR-332 GB, 25°C	>3,000,000

2.5 CE and FCC Compatibility

M.2 (S42) 3MG2-P conforms to CE and FCC requirements.

2.6 RoHS Compliance

M.2 (S42) 3MG2-P is fully compliant with RoHS directive.

2.7 Reliability

Parameter		Value
Read Cycles		Unlimited Read Cycles
Flash endurance		3,000 P/E cycles
Wear-Leveling Algorithm		Support
Bad Blocks Management		Support
Error Correct Code		Support
(Total Bytes Written) Unit:TB		
Capacity	Sequential workload	Client workload
16GB	42.6	18.8
32GB	85.2	37.5
64GB	170.5	75
128GB	340.9	150
256GB	681.8	300
* Note:		
1. Sequential: Mainly sequential write, tested by Vdbench.		
2. Client: Follow JESD218 Test method and JESD219A Workload, tested by ULINK. (The capacity lower than 64GB client workload is not specified in JEDEC219A, the values are estimated.)		
3. Based on out-of-box performance.		

2.8 Transfer Mode

M.2 (S42) 3MG2-P support following transfer mode:

Serial ATA III 6.0Gbps

Serial ATA II 3.0Gbps

Serial ATA I 1.5Gbps

2.9 Pin Assignment

Innodisk M.2 (S42) 3MG2-P uses a standard SATA pin-out. See Table 8 for M.2 (S42) 3MG2-P pin assignment.

Table 8: Innodisk M.2 (S42) 3MG2-P Pin Assignment

Signal Name	Pin #	Pin #	Signal Name
		75	GND
3.3V	74	73	GND
3.3V	72	71	GND
3.3V	70	69	GND
NC	68	67	NC
Notch	66	65	Notch
Notch	64	63	Notch
Notch	62	61	Notch
Notch	60	59	Notch
NC	58		
NC	56	57	GND
NC	54	55	NC
NC	52	53	NC
NC	50	51	GND
NC	48	49	RX+
NC	46	47	RX-
NC	44	45	GND
NC	42	43	TX-
NC	40	41	TX+
DEVSLP	38	39	GND
NC	36	37	NC
NC	34	35	NC

NC	32	33	GND
NC	30	31	NC
NC	28	29	NC
NC	26	27	GND
NC	24	25	NC
NC	22	23	NC
NC	20	21	GND
Notch	18	19	Notch
Notch	16	17	Notch
Notch	14	15	Notch
Notch	12	13	Notch
DAS/DSS	10	11	NC
NC	8	9	NC
NC	6	7	NC
3.3V	4	5	NC
3.3V	2	3	GND
		1	GND

2.10 Mechanical Dimensions

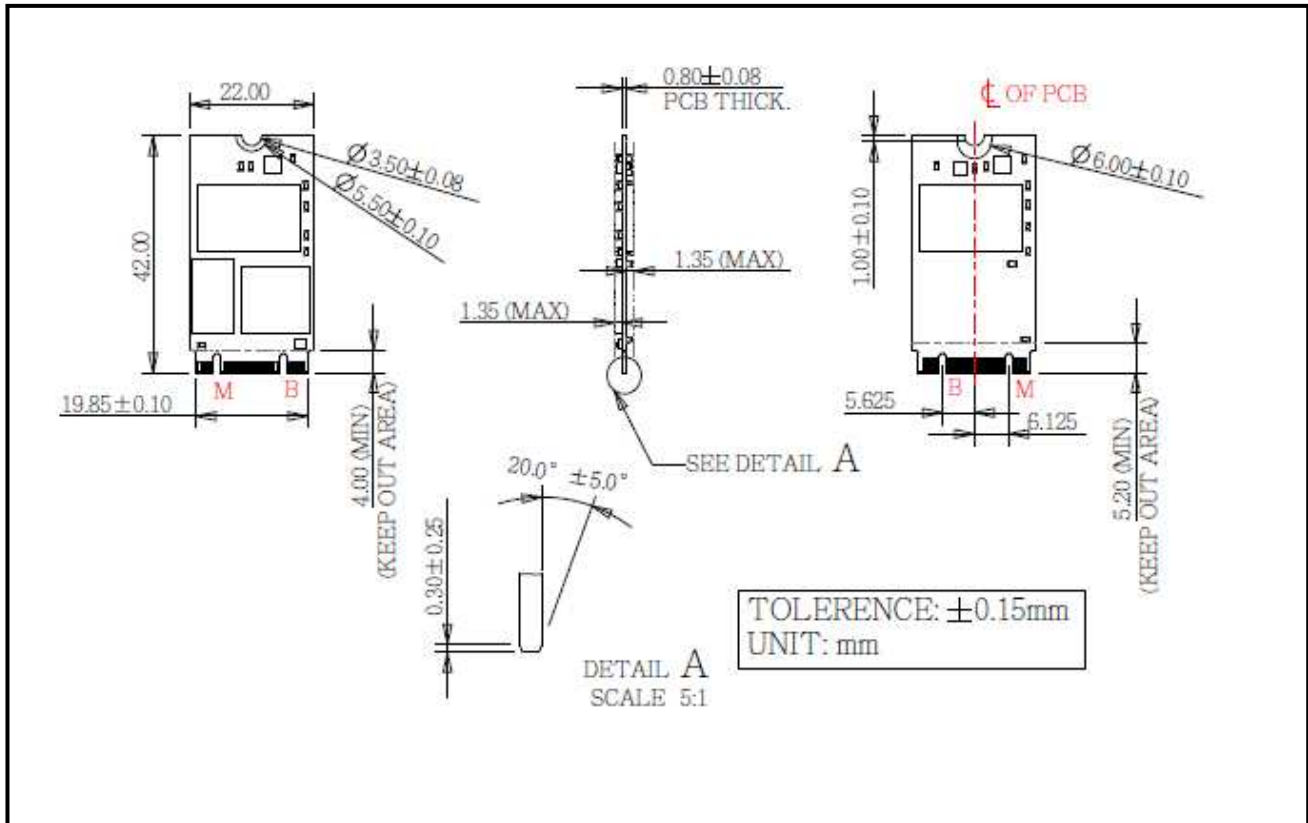

2.11 Assembly Weight

An Innodisk M.2 (S42) 3MG2-P within flash ICs, 64GB's weight is 8 grams approximately.

2.12 Seek Time

Innodisk M.2 (S42) 3MG2-P is not a magnetic rotating design. There is no seek or rotational latency required.

2.13 Hot Plug

The SSD support hot plug function and can be removed or plugged-in during operation. User has to avoid hot plugging the SSD which is configured as boot device and installed operation system.

Surprise hot plug : The insertion of a SATA device into a backplane (combine signal and power) that has power present. The device powers up and initiates an OOB sequence.

Surprise hot removal: The removal of a SATA device from a powered backplane, without first being placed in a quiescent state.

2.14 NAND Flash Memory

Innodisk M.2 (S42) 3MG2-P uses Multi Level Cell (MLC) NAND flash memory, which is non-volatility, high reliability and high speed memory storage.

3. Theory of Operation

3.1 Overview

Figure 2 shows the operation of Innodisk M.2 (S42) 3MG2-P from the system level, including the major hardware blocks.

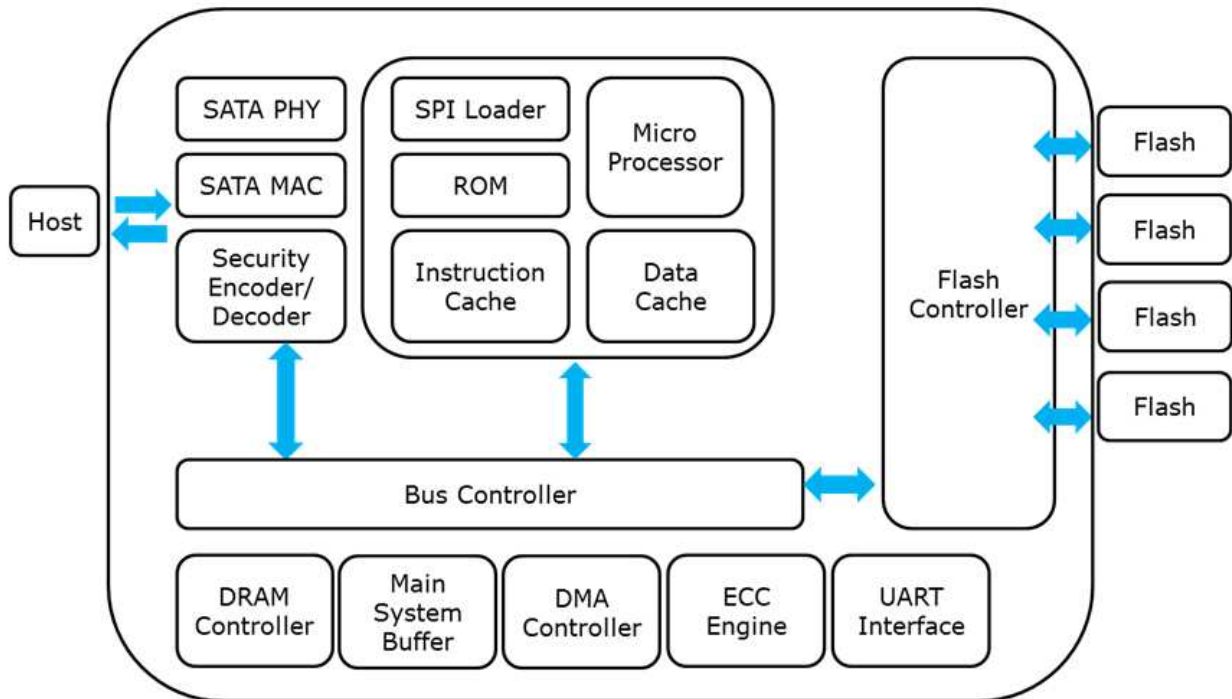

Figure 2: Innodisk M.2 (S42) 3MG2-P Block Diagram

Innodisk M.2 (S42) 3MG2-P integrates a SATA III controller and NAND flash memories. Communication with the host occurs through the host interface, using the standard ATA protocol. Communication with the flash device(s) occurs through the flash interface.

3.2 SATA III Controller

Innodisk M.2 (S42) 3MG2-P is designed with ID 201, a SATA III 6.0Gbps (Gen. 3) controller, which supports external DDR3 DRAM. The Serial ATA physical, link and transport layers are compliant with Serial ATA Gen 1, Gen 2 and Gen 3 specification (Gen 3 supports 1.5Gbps/3.0Gbps/6.0Gbps data rate). The controller has 4 channels for flash interface.

3.3 Error Detection and Correction

Highly sophisticated Error Correction Code algorithms are implemented. The ECC unit consists of the Parity Unit (parity-byte generation) and the Syndrome Unit (syndrome-byte computation). This unit implements an algorithm that can correct 66 bits per 1024 bytes in an ECC block. Code-byte generation during write operations, as well as error detection during read operation, is implemented on the fly without any speed penalties.

3.4 Wear-Leveling

Flash memory can be erased within a limited number of times. This number is called the **erase cycle limit** or **write endurance limit** and is defined by the flash array vendor. The erase cycle limit applies to each individual erase block in the flash device.

Innodisk M.2 (S42) 3MG2-P uses a static wear-leveling algorithm to ensure that consecutive writes of a specific sector are not written physically to the same page/block in the flash. This spreads flash media usage evenly across all pages, thereby extending flash lifetime.

3.5 Bad Blocks Management

Bad Blocks are blocks that contain one or more invalid bits whose reliability are not guaranteed. The Bad Blocks may be presented while the SSD is shipped, or may develop during the life time of the SSD. When the Bad Blocks is detected, it will be flagged, and not be used anymore. The SSD implement Bad Blocks management, Bad Blocks replacement, Error Correct Code to avoid data error occurred. The functions will be enabled automatically to transfer data from Bad Blocks to spare blocks, and correct error bit.

3.6 iData Guard

Innodisk's iData Guard is a comprehensive data protection mechanism that functions before and after a sudden power outage to SSD. Low-power detection terminates data writing before an abnormal power-off, while table-remapping after power-on deletes corrupt data and maintains data integrity. Innodisk's iData Guard provides effective power cycling management, preventing data stored in flash from degrading with use.

3.7 Garbage Collection/TRIM

Garbage collection and TRIM technology is used to maintain data consistency and perform continual data cleansing on SSDs. It runs as a background process, freeing up valuable controller resources while sorting good data into available blocks, and deleting bad blocks. It also significantly reduces write operations to the drive, thereby increasing the SSD's speed and lifespan.

4. Installation Requirements

4.1 M.2 (S42) 3MG2-P Pin Directions

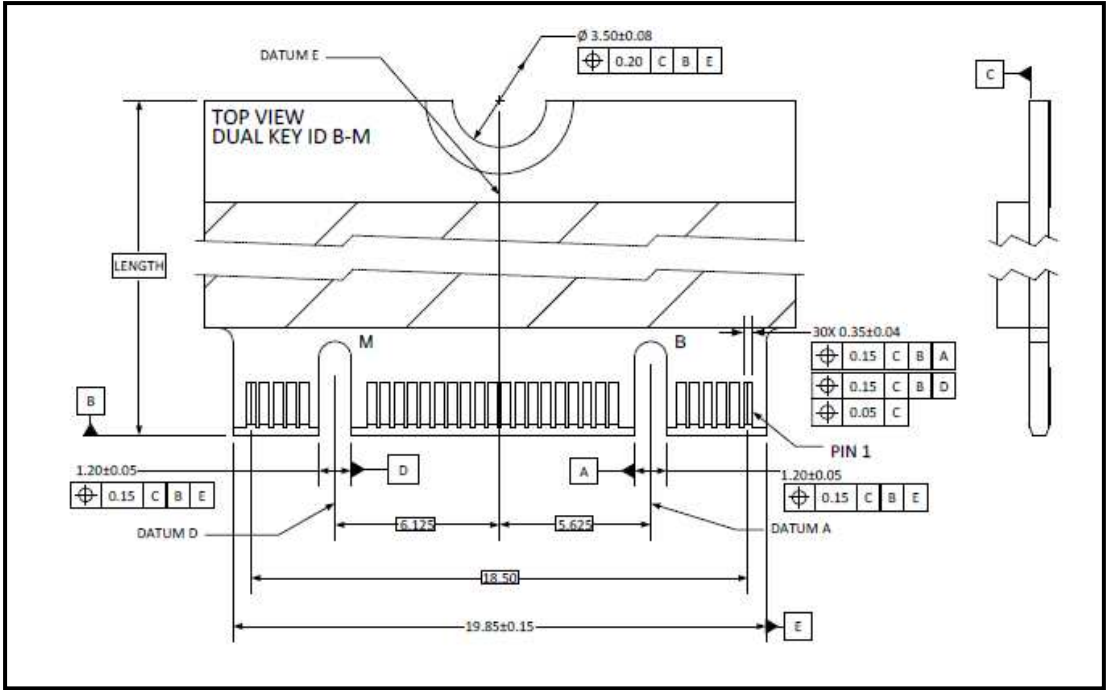

Figure 3: Signal Segment and Power Segment

4.2 Electrical Connections for M.2 (S42) 3MG2-P

A Serial ATA device may be either directly connected to a host or connected to a host through a cable. For connection via cable, the cable should be no longer than 1meter. The SATA interface has a separate connector for the power supply. Please refer to the pin description for further details.

4.3 Device Drive

No additional device drives are required. The Innodisk M.2 (S42) 3MG2-P can be configured as a boot device.

5. SMART Feature Set

Innodisk 3MG2-P series support the SMART command set and defines some vendor-specific data to report SMART attributes of SSD.

Table 9: SMART command

Value	Command	Value	Command
D0h	Read Data	D5h	Read Log
D1h	Read Attribute Threshold	D6h	Return Status
D2h	Enable/Disable Auto save	D8h	Enable SMART Operations
D3h	Save Attribute Values	D9h	Disable SMART Operations
D4h	Execute OFF-LINE Immediate	DAh	Return Status

5.1 SMART Attributes

Innodisk 3MG2-P series SMART data attributes are listed in following table.

Table 10: SMART attribute

Attribute ID (hex)	Raw Attribute Value							Attribute Name
	MSB							
1 (01h)	MSB	00	00	00	00	00	00	Raw Read Error Rate
5 (05h)	LSB	MSB	00	00	00	00	00	Reallocated Sector Count
9 (09h)	LSB			MSB	00	00	00	Power-on Hours
12 (0Ch)	LSB			MSB	00	00	00	Power Cycle Count
160 (A0h)	LSB			MSB	00	00	00	Uncorrectable sector count when read/write
161 (A1h)	LSB	MSB	00	00	00	00	00	Number of valid spare block
163 (A3h)	LSB	MSB	00	00	00	00	00	Number of initial invalid block
164 (A4h)	LSB	MSB	00	00	00	00	00	Total erase count
165 (A5h)	LSB			MSB	00	00	00	Maximum erase count
166 (A6h)	LSB			MSB	00	00	00	Minimum erase count
167 (A7h)	LSB			MSB	00	00	00	Average erase count
168 (A8h)	LSB			MSB	00	00	00	Max erase count of spec
169 (A9h)	LSB			MSB	00	00	00	Remain Life (percentage)
175 (AFh)	LSB			MSB	00	00	00	Program fail count in worst die
176 (B0h)	LSB			MSB	00	00	00	Erase fail count in worst die
177 (B1h)	LSB			MSB	00	00	00	Total wear level count
178 (B2h)	LSB	MSB	00	00	00	00	00	Runtime invalid block count
181 (B5h)	LSB			MSB	00	00	00	Total program fail count
182 (B6h)	LSB	MSB	00	00	00	00	00	Total erase fail count
187 (BBh)	LSB			MSB	00	00	00	Uncorrectable error count

192 (C0h)	LSB	MSB	00	00	00	00	00	Power-Off Retract Count
194 (C2h)	MSB	00	00	00	00	00	00	Controlled temperature
195 (C3h)	LSB			MSB	00	00	00	Hardware ECC recovered
196 (C4h)	LSB			MSB	00	00	00	Reallocation event count
198 (C6h)	LSB			MSB	00	00	00	Uncorrectable error count off-line
199 (C7h)	LSB	MSB	00	00	00	00	00	UltraDMA CRC error count
225 (E1h)	LSB						MSB	Total LBAs written (each write unit = 32MB)
232 (E8h)	LSB	MSB	00	00	00	00	00	Available reserved space
241 (F1h)	LSB						MSB	Total LBAs written (each write unit = 32MB)
242 (F2h)	LSB						MSB	Total LBAs read (each write unit = 32MB)

5. Part Number Rule

CODE	1	2	3	4	5	6	7	8	9	10	11	12	13	14	15	16	17	18	19	20	21	
	D	G	M	2	4	-	3	2	G	D	8	1	B	C	A	D	C	-	X	X	X	
Definition																						
Code 1st (Disk)											Code 14th (Operation Temperature)											
D : Disk											C: Standard Grade (0°C ~ +70°C)											
Code 2nd (Feature set)											W: Industrial Grade (-40°C ~ +85°C)											
G : Evergreen series											Code 15th (Internal control)											
Code 3rd ~5th (Form factor)											A~Z: BGA PCB version.											
M24: M.2-SATA Type 2242											Code 16th (Channel of data transfer)											
Code 7th ~9th (Capacity)											S: Single Channel											
.32G: 32GB			64G: 64GB			A28: 128GB			B56: 256GB			D: Dual Channels										
											Q: Quad Channels											
Code 10th ~12th (Controller)											Code 17th (Flash Type)											
D81: ID201											C: Toshiba MLC											
Code 13th (Flash mode)											Code 19th~21st (Customize code)											
B: Synchronous NAND.																						

Appendix

REACH

innodisk

宜鼎國際股份有限公司
Innodisk Corporation

Tel:(02)7703-3000 Fax:(02) 7703-3555 Internet: <http://www.innodisk.com/>

REACH Declaration of Conformity

Manufacturer Product: All Innodisk EM Flash and Dram products

1. 宜鼎國際股份有限公司（以下稱本公司）特此保證此售予貴公司之產品，皆符合歐盟化學品法案(Registration, Evaluation and Authorization of Chemicals: (EC) No 1907/2006 REACH) 以及附錄 XIV 中的限用物質之規定 (<http://www.echa.europa.eu/de/candidate-list-table> last updated: 12/01/2017, SVHC's 173)。

所提供之產品包含：(1) 產品或產品所使用到的所有原物料；(2) 包裝材料；(3) 設計、生產及重工過程中所使用到的所有原物料。

We Innodisk Corporation hereby declare that our products are in compliance with the requirements according to the (EC) No 1907/2006 REACH Regulation and restricted substances in Annex XIV (<http://www.echa.europa.eu/de/candidate-list-table> last updated: 12/01/2017, SVHC's 173).

Products include: 1) Product and raw material used by the product; 2) Packaging material; 3) Raw material used in the process of design, production and rework.

2. 本公司同意因本保證書或與本保證書相關事宜有所爭議時，雙方宜友好協商，達成協議。InnoDisk Corporation agrees that both parties shall settle any dispute arising from or in connection with this Declaration of Conformity by friendly negotiations.

立 保 證 書 人 (Guarantor)

Company name 公司名稱：InnoDisk Corporation 宜鼎國際股份有限公司

Company Representative 公司代表人：Randy Chien 簡川勝

Company Representative Title 公司代表人職稱：Chairman 董事長

Date 日期：2017 / 02 / 08





宜鼎國際股份有限公司
Innodisk Corporation

Tel:(02)7703-3000 Fax:(02) 7703-3555 Internet: <http://www.innodisk.com/>

RoHS 自我宣告書 (RoHS Declaration of Conformity)

Manufacturer Product: All Innodisk EM Flash and Dram products

- 一、 宜鼎國際股份有限公司 (以下稱本公司) 特此保證售予貴公司之所有產品，皆符合歐盟 2011/65/EU 及 (EU) 2015/863 關於 RoHS 之規範要求。

Innodisk Corporation declares that all products sold to the company, are complied with European Union RoHS Directive (2011/65/EU) and (EU) 2015/863 requirement.

- 二、 本公司同意因本保證書或與本保證書相關事宜有所爭議時，雙方宜友好協商，達成協議。

Innodisk Corporation agrees that both parties shall settle any dispute arising from or in connection with this Declaration of Conformity by friendly negotiations.

Name of hazardous substance	Limited of RoHS ppm (mg/kg)
鉛 (Pb)	< 1000 ppm
汞 (Hg)	< 1000 ppm
鎘 (Cd)	< 100 ppm
六價鉻 (Cr 6+)	< 1000 ppm
多溴聯苯 (PBBs)	< 1000 ppm
多溴二苯醚 (PBDEs)	< 1000 ppm
鄰苯二甲酸二(2-乙基己基)酯 (DEHP)	< 1000 ppm
鄰苯二甲酸丁酯苯甲酯 (BBP)	< 1000 ppm
鄰苯二甲酸二丁酯 (DBP)	< 1000 ppm
鄰苯二甲酸二異丁酯 (DIBP)	< 1000 ppm

立 保 證 書 人 (Guarantor)

Company name 公司名稱: Innodisk Corporation 宜鼎國際股份有限公司

Company Representative 公司代表人: Randy Chien 簡川騰

Company Representative Title 公司代表人職稱: Chairman 董事長

Date 日期: 2017 / 01 / 18

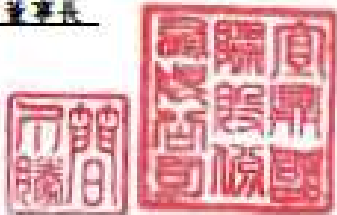

CE(EN55022/EN55024)

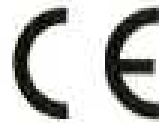

VERIFICATION OF COMPLIANCE

This Verification of Compliance is hereby issued to the below named company. The test results of this report relate only to the tested sample identified in this report.

**Technical Standard: EMC DIRECTIVE 2014/30/EU
(EN55022 / EN55024)**

General Information

Applicant: Innodisk Corporation
5F., No. 237, Sec. 1, Datong Rd., Xizhi Dist.,
New Taipei City 22161, Taiwan (R.O.C)

Product Description

EUT Description: M.2
Brand Name: Innodisk
Model Number: M.2 (S42) 35*#-&
S:Flash type: (S:SLC, I:SLC, M:MLC, T:3D-TLC)
*:Product line: (E:Embedded, G:EverGreen, R:InnoRobust)
#:Product Generation: (empty, 0-9)
&:Product line: (empty, P:Plus)

Measurement Standard

EN 55022: 2010 / AC: 2011
EN 61000-3-2: 2014
EN 61000-3-3: 2013
EN 55024: 2010 + A1: 2015
(IEC 61000-4-2: 2008; IEC 61000-4-3: 2006 + A1: 2007 + A2: 2010; IEC 61000-4-4: 2012;
IEC 61000-4-5: 2014; IEC 61000-4-6: 2013; IEC 61000-4-8: 2009; IEC 61000-4-11: 2004)

Measurement Facilities

Xindian Lab.: Compliance Certification Services Inc.
No.163-1, Zhongsheng Rd., Xindian Dist., New Taipei City, 23151 Taiwan.
Tel: +886-2-22170894 / Fax: +886-2-22171029

This device has been shown to be in compliance with and was tested in accordance with the measurement procedures specified in the Standards & Specifications listed above and as indicated in the measurement report number: T161004D11-E

Sam Hu / Assistant Manager

Date: October 11, 2016

CE(EN55032)



VERIFICATION OF COMPLIANCE

This Verification of Compliance is hereby issued to the below named company. The test results of this report relate only to the tested sample identified in this report.

**Technical Standard: EMC DIRECTIVE 2014/30/EU
(EN55032)**

General Information

Applicant: Innodisk Corporation
5F., No. 237, Sec. 1, Datong Rd., Xizhi Dist.,
New Taipei City 22161, Taiwan (R.O.C)

Product Description

EUT Description: M.2
Brand Name: Innodisk
Model Number: M.2 (S42) 35*#-&
S:Flash type: (S:SLC, L:SLC, M:MLC, T:3D TLC)
*:Product line: (E:Embedded, G:EverGreen, R:InnoRobust)
#:Product Generation: (empty, 0-9)
&:Product line: (empty, P:Plus)

Measurement Standard

EN 55032: 2012 / AC: 2013
CISPR 32: 2012

Measurement Facilities

Xindian Lab.: Compliance Certification Services Inc.
No.163-1, Zhongsheng Rd., Xindian Dist., New Taipei City, 23151 Taiwan.
Tel: +886-2-22170894 / Fax: +886-2-22171029

This device has been shown to be in compliance with and was tested in accordance with the measurement procedures specified in the Standards & Specifications listed above and as indicated in the measurement report number: T161004D11-E

Sam Hu / Assistant Manager

Date: October 11, 2016

CCSRF
程颢科技股份有限公司
Compliance Certification Services Inc.



VERIFICATION OF COMPLIANCE

This Verification of Compliance is hereby issued to the below named company. The test results of this report relate only to the tested sample identified in this report.

**Technical Standard: FCC Part 15 Class B
IC ICES-003**

General Information

Applicant: Innodisk Corporation
5F., No. 237, Sec. 1, Datong Rd., Xizhi Dist.,
New Taipei City 22161, Taiwan (R.O.C)

Product Description

EUT Description: M.2
Brand Name: Innodisk
Model Number: M.2 (S42) 3S*#-&
S:Flash type: (S:SLC, I:SLC, M:MLC, T:3D TLC)
*:Product line: (E:Embedded, G:EverGreen, R:InnoRobust)
#:Product Generation: (empty, 0-9)
&:Product line: (empty, P:Plus)

Measurement Facilities

Xindian Lab: *Compliance Certification Services Inc.*
No.163-1, Zhongsheng Rd., Xindian Dist., New Taipei City, 23151 Taiwan.
Tel: +886-2-22170894 / Fax: +886-2-22171029

This device has been shown to be in compliance with and was tested in accordance with the measurement procedures specified in the Standards & Specifications listed above and as indicated in the measurement report number: T161004D14-E

Sam Hu / Assistant Manager

Date: October 11, 2016

