

M.2 (S42)

InnoOSR 3T07

Customer: _____

Customer

Part

Number: _____

Innodisk

Part

Number: _____

Innodisk

Model Name: _____

Date: _____

Innodisk Approver	Customer Approver

Table of contents

1. PRODUCT OVERVIEW	7
1.1 INTRODUCTION OF INNODISK M.2 (S42) 3T07	7
1.2 PRODUCT VIEW AND MODELS.....	7
1.3 SATA INTERFACE	8
2.1 CAPACITY AND DEVICE PARAMETERS.....	8
2.2 PERFORMANCE	8
2.3 ELECTRICAL SPECIFICATIONS	9
2.3.1 Power Requirement.....	9
2.3.2 Power Consumption.....	9
2.4 ENVIRONMENTAL SPECIFICATIONS.....	9
2.4.1 Temperature Ranges	9
2.4.2 Humidity.....	9
2.4.3 Shock and Vibration.....	9
2.4.4 Mean Time between Failures (MTBF).....	10
2.5 CE AND FCC COMPATIBILITY.....	10
2.6 RoHS COMPLIANCE.....	10
2.7 RELIABILITY.....	11
2.8 TRANSFER MODE.....	11
2.9 PIN ASSIGNMENT.....	12
3. THEORY OF OPERATION.....	16
3.1 OVERVIEW.....	16
3.2 SATA III CONTROLLER	16
3.3 ERROR DETECTION AND CORRECTION.....	16
3.4 WEAR-LEVELING.....	17
3.5 BAD BLOCKS MANAGEMENT.....	17
3.6 iDATA GUARD	17
3.7 GARBAGE COLLECTION.....	17
3.8 TRIM.....	17
3.9 iPOWER GUARD	17
3.10 DIE RAID.....	18
4. INSTALLATION REQUIREMENTS.....	20
4.1 M.2 (S42) 3T07 PIN DIRECTIONS	20
4.2 ELECTRICAL CONNECTIONS FOR M.2 (S42) 3T07.....	21
4.3 DEVICE DRIVE.....	21
5. SMART FEATURE SET	22
5.1 SMART ATTRIBUTES.....	22

6. PART NUMBER RULE..... 24

7. APPENDIX..... 25

REVISION HISTORY

Revision	Description	Date
V1.0	Official Release	Dec., 2020
V1.1	Correct Pin Assignment	Feb., 2021
V1.2	Add New Demo Cable	May, 2021

List of Tables

TABLE 1: DEVICE PARAMETERS	8
TABLE 2: PERFORMANCE	8
TABLE 3: INNODISK M.2 (S42) 3T07 POWER REQUIREMENT	9
TABLE 4: POWER CONSUMPTION	9
TABLE 5: TEMPERATURE RANGE FOR M.2 (S42) 3T07	9
TABLE 6: SHOCK/VIBRATION TESTING FOR M.2 (S42) 3T07	9
TABLE 7: M.2 (S42) 3T07 MTBF	10
TABLE 8: M.2 (S42) 3T07 TBW	11
TABLE 9: INNODISK M.2 (S42) 3T07 PIN ASSIGNMENT	12
TABLE 10: SMART COMMAND	22
TABLE 11: SMART ATTRIBUTE	22

List of Figures

FIGURE 1: INNODISK M.2 (S42) 3T07 (TYPE 2242)	7
FIGURE 2: INNODISK M.2 (S42) 3T07 DIAGRAM (TSOP)	14
FIGURE 3: INNODISK M.2 (S42) 3T07 DIAGRAM (BGA)	15
FIGURE 4: INNODISK M.2 (S42) 3T07 BLOCK DIAGRAM	16
FIGURE 5: SIGNAL SEGMENT AND POWER SEGMENT	20

1. Product Overview

1.1 Introduction of Innodisk M.2 (S42) 3T07

Innodisk 2.5" SATA SSD 3T07 provides high capacity flash memory Solid State Drive (SSD) that electrically complies with Serial ATA (SATA) standard supporting up to SATA III standard (6.0Gb/s) speed and capable of achieving excellent performance with its 4 channels 4CE Innodisk ID301 controller. Besides outstanding balance of performance, rich form factors, capacity and customization flexibility, the key feature of InnoOSR family is the single-device, Firmware LBA level OS & Data back-up capability which enables on-site recovery of operating system by simple procedure such as GPIO triggering or application commands.

CAUTION *TRIM must be enabled.*

TRIM enables SSD's controller to skip invalid data instead of moving. It can free up significant amount of resources, extends the lifespan of SSD by reducing erase, and write cycles on the SSD. Innodisk's handling of garbage collection along with TRIM command improves write performance on SSDs.

1.2 Product View and Models

Innodisk M.2 (S42) 3T07 is available in following capacities with 3D TLC flash ICs.

M.2 (S42) 3T07 32GB

M.2 (S42) 3T07 256GB

M.2 (S42) 3T07 64GB

M.2 (S42) 3T07 512GB

M.2 (S42) 3T07 128GB

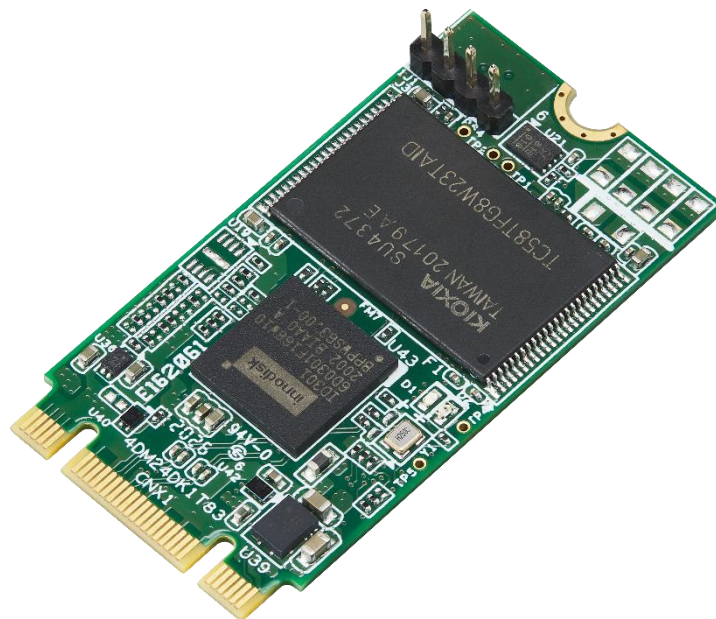

Figure 1: Innodisk M.2 (S42) 3T07 (type 2242)

1.3 SATA Interface

Innodisk 2.5" SATA SSD 3T07 supports SATA III(6.0Gb/s) interface, and compliant with SATA I (1.5Gb/s) and SATA II(3.0Gb/s).

2. Product Specifications

2.1 Capacity and Device Parameters

M.2 (S42) 3T07 device parameters are shown in Table 1.

Capacity	P/N	OS back-up capacity (GB)	LBA	User Capacity(GB)
32GB	DUM24-32GDK1E*1 ^{*2} F10G	10	32771008	15.6
64GB	DUM24-64GDK1E*1 ^{*2} F10G	10	96259888	45.9
	DUM24-64GDK1E*1 ^{*2} F20G	20	75288368	35.9
128GB	DUM24-A28DK1E*1 ^{*2} F10G	10	213470128	101.7
	DUM24-A28DK1E*1 ^{*2} F20G	20	192498608	91.7
	DUM24-A28DK1E*1 ^{*2} F30G	30	171527088	81.7
256GB	DUM24-B56DK1E*1 ^{*2} F10G	10	447890608	213.5
	DUM24-B56DK1E*1 ^{*2} F20G	20	426919088	203.5
	DUM24-B56DK1E*1 ^{*2} F30G	30	405947568	193.5
512GB	DUM24-C12DK1E*1 ^A *2F10G	10	916731568	437.1
	DUM24-C12DK1E*1 ^A *2F20G	20	895760048	427.1
	DUM24-C12DK1E*1 ^A *2F30G	30	874788528	417.1
Note	^{*1} : C: standard temperature (0°C to 70°C); W: wide temperature (-40°C to 85°C) ^{*2} : S: Single-channel; D: Dual-channels; Q: Quad-Channels			

Table 1: Device parameters

Note: User capacities vary depend on size of hidden OS back-up area.

2.2 Performance

Burst Transfer Rate: 6.0Gbps

Table 2: Performance

Capacity	Unit	32GB	64GB	128GB	256GB	512GB
Sequential* Read (max.)	MB/s	170	350	470	470	500
Sequential* Write (max.)		35	70	140	290	330
4KB Random** Read (Q32T1)	IOPS	11800	21000	39500	48500	57000
4KB Random** Write (Q32T1)		9100	18500	36500	75500	73500

Note: * Performance results are based on CrystalDiskMark 6.0.2 with file size 1000MB

2.3 Electrical Specifications

2.3.1 Power Requirement

Table 3: Innodisk M.2 (S42) 3T07 Power Requirement

Item	Symbol	Rating	Unit
Input voltage	V _{IN}	+3.3 DC +- 5%	V

2.3.2 Power Consumption

Table 4: Power Consumption

Mode	Power Consumption (mA)				
	32GB	64GB	128GB	256GB	512GB
Read(RMA)	220	280	370	350	240
Write(RMA)	220	280	460	470	300
Idle(RMA)	195	215	215	230	180
Boot-Up Peak	975	990	1005	1005	450

* Target: M.2 (S42) 3T07

2.4 Environmental Specifications

2.4.1 Temperature Ranges

Table 5: Temperature range for M.2 (S42) 3T07

Temperature	Range
Operating	Standard Grade: 0°C to +70°C
	Industrial Grade: -40°C to +85°C
Storage	-55°C to +95°C

2.4.2 Humidity

Relative Humidity: 10-95%, non-condensing

2.4.3 Shock and Vibration

Table 6: Shock/Vibration Testing for M.2 (S42) 3T07

Reliability	Test Conditions	Reference Standards
Vibration	7 Hz to 2K Hz, 20G, 3 axes	IEC 68-2-6
Mechanical Shock	Duration: 0.5ms, 1500 G, 3 axes	IEC 68-2-27

2.4.4 Mean Time between Failures (MTBF)

Table 7 summarizes the MTBF prediction results for various M.2 (S42) 3T07 configurations. The analysis was performed using a RAM Commander™ failure rate prediction.

- **Failure Rate:** The total number of failures within an item population, divided by the total number of life units expended by that population, during a particular measurement interval under stated condition.
- **Mean Time between Failures (MTBF):** A basic measure of reliability for repairable items: The mean number of life units during which all parts of the item perform within their specified limits, during a particular measurement interval under stated conditions.

Table 7: M.2 (S42) 3T07 MTBF

Product	Condition	MTBF (Hours)
Innodisk M.2 (S42) 3T07	Telcordia SR-332 GB, 25°C	>3,000,000

2.5 CE and FCC Compatibility

M.2 (S42) 3T07 conforms to CE and FCC requirements.

2.6 RoHS Compliance

M.2 (S42) 3T07 is fully compliant with RoHS directive.

2.7 Reliability

Table 8: M.2 (S42) 3T07 TBW

Parameter		Value
Read Cycles		Unlimited Read Cycles
Flash endurance		3,000 P/E cycles
Wear-Leveling Algorithm		Support
Bad Blocks Management		Support
Error Correct Code		Support
TBW* (Total Bytes Written) Unit: TB		
Capacity	Sequential workload	Client workload
32GB	84.3	37.5
64GB	168.6	75
128GB	337.2	150
256GB	674.4	250
512GB	1348.8	500
* Note:		
<ol style="list-style-type: none"> 1. Sequential: Mainly sequential write, tested by Vdbench. 2. Client: Follow JESD218 Test method and JESD219A Workload, tested by ULINK. (The capacity lower than 64GB client workload is not specified in JEDEC219A, the values are estimated.) 3. Based on out-of-box performance. 		

2.8 Transfer Mode

M.2 (S42) 3T07 support following transfer mode:

Serial ATA III 6.0Gbps

Serial ATA II 3.0Gbps

Serial ATA I 1.5Gbps

2.9 Pin Assignment

Innodisk M.2 (S42) 3T07 uses a standard SATA pin-out. See Table 9 for M.2 (S42) 3T07 pin assignment.

Table 9: Innodisk M.2 (S42) 3T07 Pin Assignment

Signal Name	Pin #	Pin #	Signal Name
		75	GND
3.3V	74	73	GND
3.3V	72	71	GND
3.3V	70	69	GND
NC	68	67	NC
Notch	66	65	Notch
Notch	64	63	Notch
Notch	62	61	Notch
Notch	60	59	Notch
NC	58		
NC	56	57	GND
NC	54	55	NC
NC	52	53	NC
NC	50	51	GND
NC	48	49	RX+
NC	46	47	RX-
NC	44	45	GND
NC	42	43	TX-
NC	40	41	TX+
DEVSLP	38	39	GND
NC	36	37	NC
NC	34	35	NC
NC	32	33	GND
NC	30	31	NC
NC	28	29	NC
NC	26	27	GND
NC	24	25	NC
NC	22	23	NC
NC	20	21	GND
Notch	18	19	Notch
Notch	16	17	Notch
Notch	14	15	Notch
Notch	12	13	Notch

DAS/DSS	10	11	NC
NC	8	9	NC
NC	6	7	NC
3.3V	4	5	NC
3.3V	2	3	Default NC. Reserved GPIO 13 for OS Recovery Triggering
		1	GND

2.10 Mechanical Dimensions

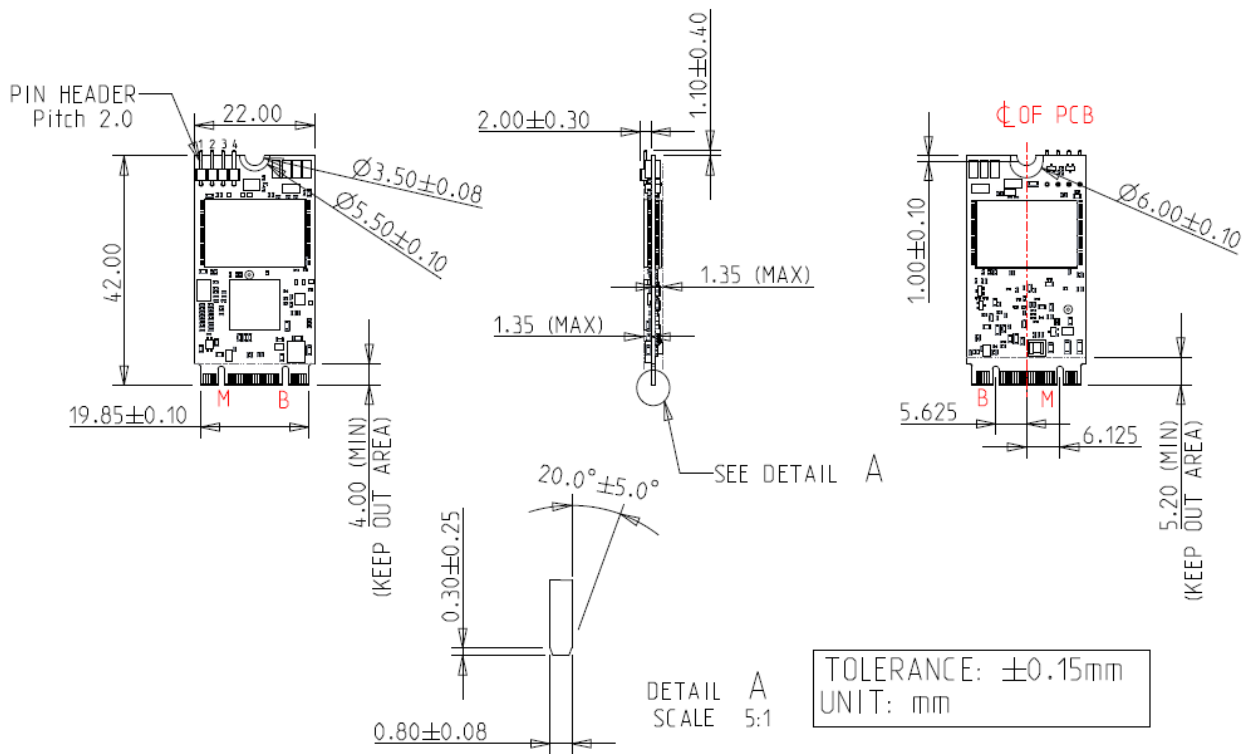

Figure 2: Innodisk M.2 (S42) 3T07 diagram (TSOP) with Horizontal Pin Headers

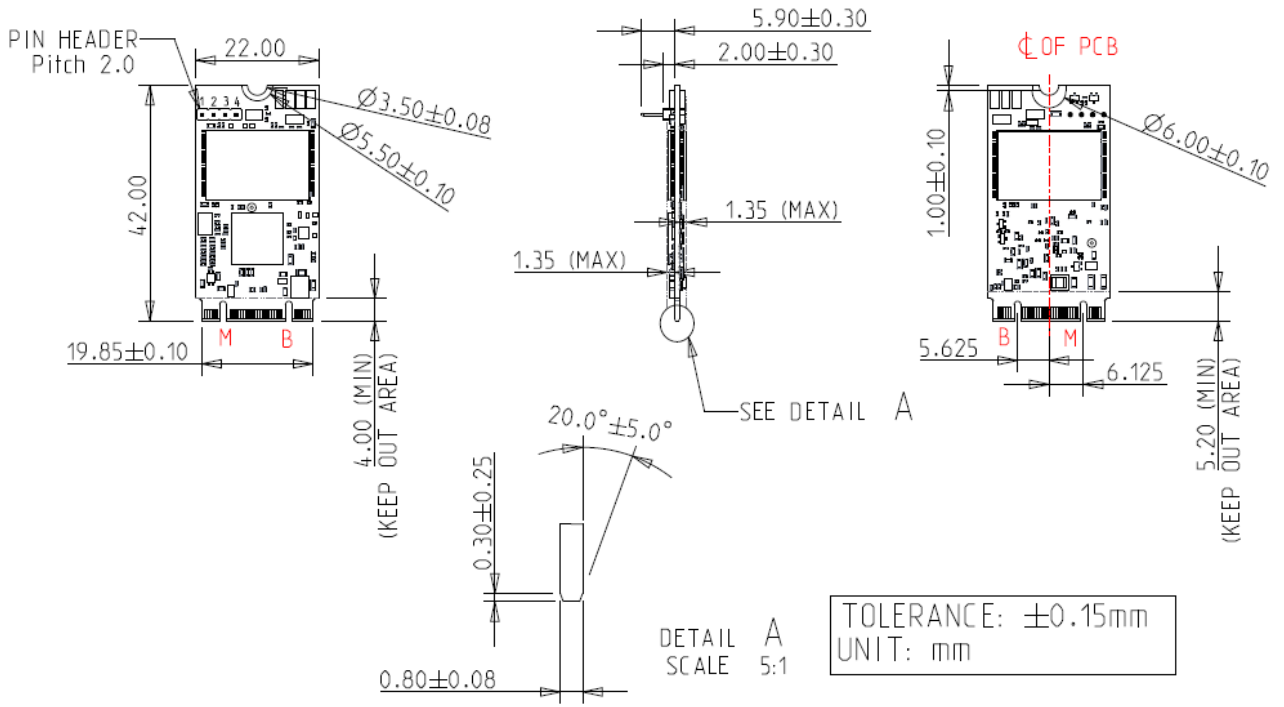

Figure 3: Innodisk M.2 (S42) 3T07 diagram (TSOP) with Vertical Pin Headers

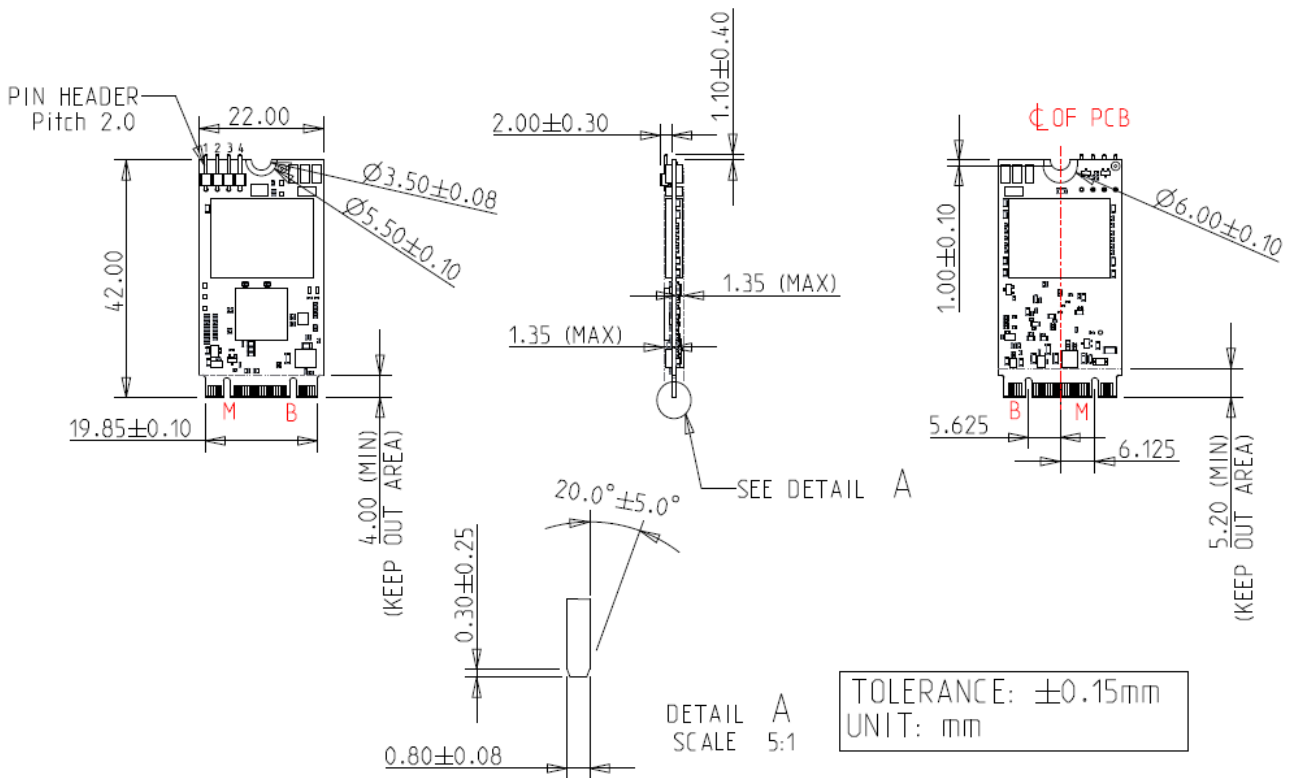

Figure 4: Innodisk M.2 (S42) 3T07 diagram (BGA for 512GB model) with Horizontal Pin Headers

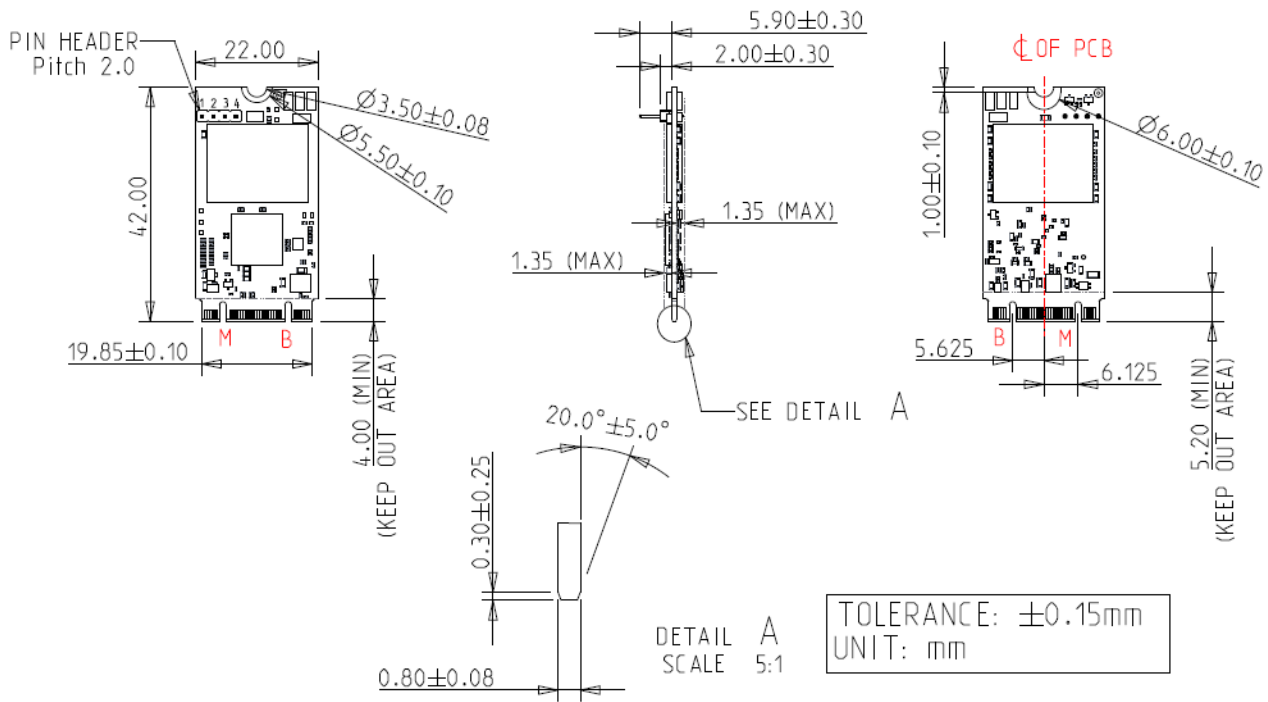

Figure 5: Innodisk M.2 (S42) 3T07 diagram (BGA for 512GB model) with Vertical Pin Headers

2.11 Assembly Weight

An Innodisk M.2 (S42) 3T07 within flash ICs, 64GB's weight is 8 grams approximately.

2.12 Seek Time

Innodisk M.2 (S42) 3T07 is not a magnetic rotating design. There is no seek or rotational latency required.

2.13 Hot Plug

The SSD support hot plug function and can be removed or plugged-in during operation. User has to avoid hot plugging the SSD which is configured as boot device and installed operation system.
 Surprise hot plug : The insertion of a SATA device into a backplane (combine signal and power) that has power present. The device powers up and initiates an OOB sequence.

Surprise hot removal: The removal of a SATA device from a powered backplane, without first being placed in a quiescent state.

2.14 NAND Flash Memory

Innodisk M.2 (S42) 3T07 uses 3D Triple Level Cell (TLC) NAND flash memory, which is non-volatility, high reliability and high speed memory storage.

3. Theory of Operation

3.1 Overview

Figure 4 shows the operation of Innodisk M.2 (S42) 3TO7 from the system level, including the major hardware blocks.

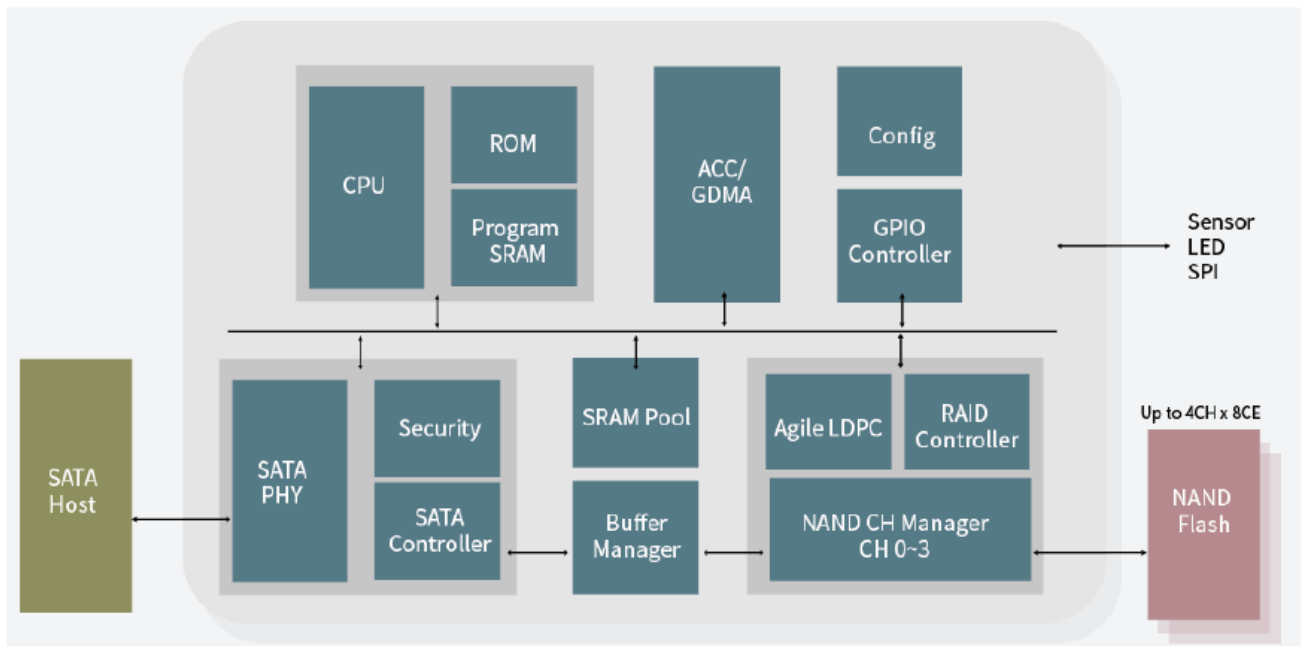

Figure 6: Innodisk M.2 (S42) 3TO7 Block Diagram

Innodisk M.2 (S42) 3TO7 integrates a SATA III controller and NAND flash memories. Communication with the host occurs through the host interface, using the standard ATA protocol. Communication with the flash device(s) occurs through the flash interface.

3.2 SATA III Controller

Innodisk M.2 (S42) 3TO7 is designed with SATA III 6.0Gbps (Gen. 3) Controller, a SATA III 6.0Gbps (Gen. 3) controller. The Serial ATA physical, link and transport layers are compliant with Serial ATA Gen 1, Gen 2 and Gen 3 specification (Gen 3 supports 1.5Gbps/3.0Gbps/6.0Gbps data rate). The controller has 2 channels for flash interface.

3.3 Error Detection and Correction

Innodisk 2.5" SATA SSD 3TO7 is designed with hardware LDPC ECC engine with hard-decision and soft-decision decoding. Low-density parity-check (LDPC) codes have excellent error correcting performance close to the Shannon limit when decoded with the belief-propagation (BP) algorithm using soft-decision information.

3.4 Wear-Leveling

Flash memory can be erased within a limited number of times. This number is called the **erase cycle limit** or **write endurance limit** and is defined by the flash array vendor. The erase cycle limit applies to each individual erase block in the flash device.

Innodisk M.2 (S42) 3T07 uses a static wear-leveling algorithm to ensure that consecutive writes of a specific sector are not written physically to the same page/block in the flash. This spreads flash media usage evenly across all pages, thereby extending flash lifetime.

3.5 Bad Blocks Management

Bad Blocks are blocks that contain one or more invalid bits whose reliability are not guaranteed. The Bad Blocks may be presented while the SSD is shipped, or may develop during the life time of the SSD. When the Bad Blocks is detected, it will be flagged, and not be used anymore. The SSD implement Bad Blocks management, Bad Blocks replacement, Error Correct Code to avoid data error occurred. The functions will be enabled automatically to transfer data from Bad Blocks to spare blocks, and correct error bit.

3.6 iData Guard

Innodisk's iData Guard is a comprehensive data protection mechanism that functions before and after a sudden power outage to SSD. Low-power detection terminates data writing before an abnormal power-off, while table-remapping after power-on deletes corrupt data and maintains data integrity. Innodisk's iData Guard provides effective power cycling management, preventing data stored in flash from degrading with use.

3.7 Garbage Collection

Garbage collection is used to maintain data consistency and perform continual data cleansing on SSDs. It runs as a background process, freeing up valuable controller resources while sorting good data into available blocks, and deleting bad blocks. It also significantly reduces write operations to the drive, thereby increasing the SSD's speed and lifespan.

3.8 Trim

The Trim command is designed to enable the operating system to notify the SSD which pages no longer contain valid data due to erases either by the user or operating system itself. During a delete operation, the OS will mark the sectors as free for new data and send a Trim command to the SSD to mark them as not containing valid data. After that the SSD knows not to preserve the contents of the block when writing a page, resulting in less write amplification with fewer writes to the flash, higher write speed, and increased drive life.

3.9 iPower Guard

iPower Guard technology is a set of preventive measures that protect the SSD in an unstable power supply environment. This comprehensive package comprises safeguards for startup and

shutdown to maintain device performance and ensure data integrity.

3.10 Die RAID

Die RAID is a controller function which leveraged user capacity to back up the data in NAND flash. Die RAID supported can ensure the user data in the NAND Flash more consistent in certain scenario. Innodisk M.2 (S42) 3T07 series is default enable the Die RAID function for the industrial application.

3.11 InnoOSR Back-up/Recovery

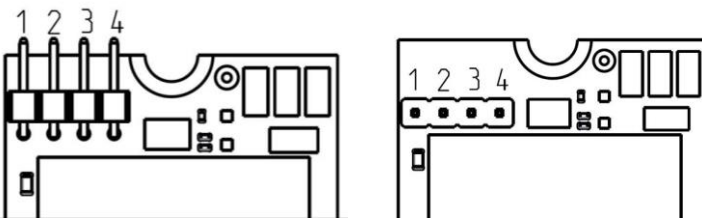

Pin Header Number	Pin Define	Installation for Innodisk Demo Cable (PN: 7W3000000870)	Rating
1	GND	Red cable	NA
2	GPIO Pin8, Output for InnoOSR LED indication	Blue cable_0 that co-axis with red cable	3.3V ± 5%
3	GND	Blue cable_1/2	NA
4	GPIO Pin13, Input for InnoOSR Recovery Trigger, Low active	Blue cable_1/2	3.3V ± 5%



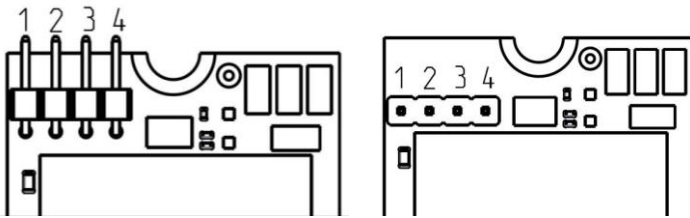

Pin Header Number	Pin Define	Installation for Innodisk Demo Cable (PN: 7W3000000920)	Rating
1	GND	NA	NA
2	GPIO Pin8, Output for InnoOSR LED indication	Blue cable_1	3.3V ± 5%
3	GND	Red	NA
4	GPIO Pin13, Input for InnoOSR Recovery Trigger, Low active	Blue cable_2	3.3V ± 5%

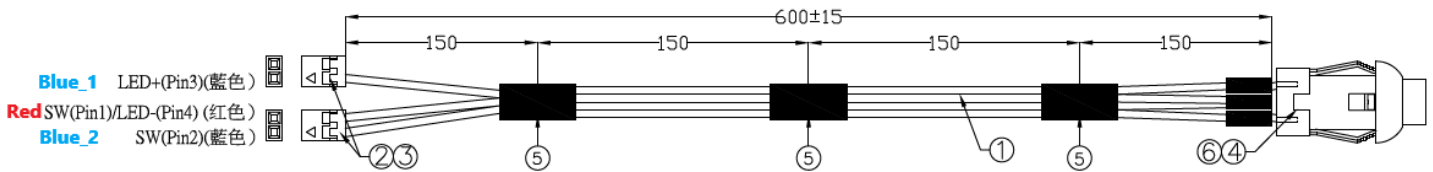

Main feature of InnoOSR family is the OS back up and swift recovery mechanism, which allow field repair easier than ever for malfunction systems with software level damages. As shown in above picture, 1 x 4 pin headers located on the end of M.2 PCB can be used to interact with firmware of InnoOSR device to perform OS recovery process and provide LED signal, which indicates the recovery status. In above picture, the push-button cable with green LED are with PN of 7W3000000870/7W3000000920 and are not included in standard InnoOSR product PN but can be order separately for trial purpose.

3.11.1 InnoOSR Back-up Implementation Process

Process of InnoOSR Back-up / Recovery can be found in Independent "Innodisk InnoOSR Implementation Process" document.

3.11.2 InnoOSR Recovery Triggering Methods

There are two methods to trigger OS recovery process listed as follows:

Button triggering: With Pin3 & 4 of the 1 x 4 pin headers located on the end of M.2 PCB shorted for more than 5 seconds, the recovery process will start. Back-up image of which this process leads to can be established by our InnoOSR software tool.

Software triggering: Our InnoOSR software tool can also trigger the recovery process. However, due to the recovery process itself essentially means covering your operating OS up, you may experience system crash and progress bar can only be read via LED signal linked directly to InnoOSR device.

4. Installation Requirements

4.1 M.2 (S42) 3T07 Pin Directions

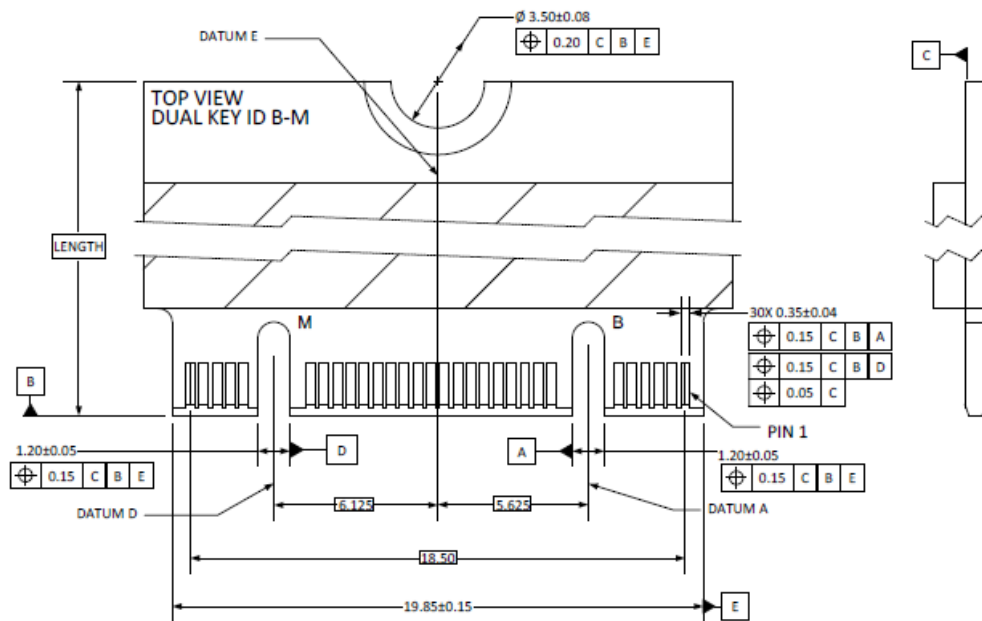

Figure 7: Signal Segment and Power Segment

4.2 Electrical Connections for M.2 (S42) 3T07

A Serial ATA device may be either directly connected to a host or connected to a host through a cable. For connection via cable, the cable should be no longer than 1meter. The SATA interface has a separate connector for the power supply. Please refer to the pin description for further details.

4.3 Device Drive

No additional device drives are required. The Innodisk M.2 (S42) 3T07 can be configured as a boot device.

5. SMART Feature Set

Innodisk 3T07 series support the SMART command set and defines some vendor-specific data to report SMART attributes of SSD.

Table 10: SMART command

Value	Command	Value	Command
D0h	Read Data	D5h	Read Log
D1h	Read Attribute Threshold	D6h	Return Status
D2h	Enable/Disable Auto save	D8h	Enable SMART Operations
D3h	Save Attribute Values	D9h	Disable SMART Operations
D4h	Execute OFF-LINE Immediate	DAh	Return Status

5.1 SMART Attributes

Innodisk 3T07 series SMART data attributes are listed in following table.

Table 11: SMART attribute

Attribute ID (hex)	Value	Raw Attribute Value						Rsv	Attribute Name
01	X								Read Error Rate
05	X	LSB	MSB	00	00	00	00	00	Later Bad
09	LSB	LSB	MSB	00	00	00	00	00	Power-On hours Count
0C	LSB	LSB	MSB	00	00	00	00	00	Drive Power Cycle Count
A3	X	LSB			MSB	00	00	00	Total Bad Block Count
A5	LSB	LSB			MSB	00	00	00	Max Erase count
A7	LSB	LSB			MSB	00	00	00	Avg Erase count
A9	LSB	LSB	00	00	00	00	00	00	Device Life
AA	X	LSB	MSB	00	00	00	00	00	Spare Block Count
AB	LSB	LSB	MSB	00	00	00	00	00	Program fail count
AC	LSB	LSB	MSB	00	00	00	00	00	Erase fail count
C0	LSB	LSB	MSB	00	00	00	00	00	Unexpected Power Loss Count

C2	LSB			MIN		MAX	00	00	Temperature
E5		ID 0	ID 1	ID 2	ID 3	ID 4	ID 5		Flash ID
EB			MSB	LSB	MSB	LSB	MSB	LSB	Later bad block info (Read/Write/Erase)
F1	00	LSB			MSB	00	00	00	Total LBA written(LBA=32MB)
F2	00	LSB			MSB	00	00	00	Total LBA read(LBA=32MB)

6. Part Number Rule

CODE	1	2	3	4	5	6	7	8	9	10	11	12	13	14	15	16	17	18	19	20	21
		D	U	M	2	4	-	3	2	G	D	K	1	E	C	1	D	F	1	0	G
Definition																					
Code 1st (Disk)											Code 14th (Operation Temperature)										
D : Disk											C: Standard Grade (0°C~ +70°C)										
Code 2nd (Feature set)											W: Industrial Grade (-40°C~ +85°C)										
U : Embedded series																					
Code 3rd ~5th (Form factor)											Code 15th (Internal control)										
M24: M.2 Type 2242-B-M											1~9: TSOP PCB version.										
											A: BGA PCB version.										
Code 7th ~9th (Capacity)											Code 16th (Channel of data transfer)										
32G: 32GB			64G: 64GB			A28: 128GB					S: Single Channel										
B56: 256GB			C12:512GB								D: Dual Channels										
											Q: Quad Channels										
Code 10th ~12th (Controller)											Code 17th (Flash Type)										
DK1: SATA 3T07											F: Kioxia 3D TLC										
Code 13th (Flash mode)											Code 18th ~20th (Hidden Area Size)										
E: 64 layers 3D TLC											10G: 10GB Hidden										
											20G: 20GB Hidden										
											30G: 30GB Hidden										
											Code 21st~ (Customization Code)										

7. Appendix

REACH

innodisk

宜鼎國際股份有限公司
Innodisk Corporation
REACH Declaration

Tel:(02)7703-3000 Fax:(02) 7703-3555 Internet: <http://www.innodisk.com/>

We hereby confirm that the product(s) delivered to

Innodisk P/N	Description
All Innodisk EM Flash and Dram Products	

- contain(s) **no** hazardous substances or constituents exceeding the defined threshold 0.1 % by weight in homogenous material if not otherwise specified, as described in the candidate list table currently including 191 substances and shown on the ECHA website (<http://echa.europa.eu/de/candidate-list-table>).
- contain(s) one or more hazardous substances or constituents exceeding 0.1 % by weight in homogenous material if not otherwise specified in candidate list table. Where the threshold value is exceeded, the substances in question are to be declared in accompanying Appendix A & B.
- Comply with REACH Annex XVII.

Guarantor

Company name 公司名稱： Innodisk Corporation 宜鼎國際股份有限公司

Company Representative 公司代表人： Randy Chien 簡川勝

Company Representative Title 公司代表人職稱： Chairman 董事長

Date 日期： 2018 / 02 / 08



RoHS**宜鼎國際股份有限公司
Innodisk Corporation**

Page 1/1

Tel:(02)7703-3000 Fax:(02) 7703-3555 Internet: http://www.innodisk.com/

RoHS 自我宣告書 (RoHS Declaration of Conformity)**Manufacturer Product: All Innodisk EM Flash and Dram products**

- 一、 宜鼎國際股份有限公司（以下稱本公司）特此保證售予貴公司之所有產品，皆符合歐盟 2011/65/EU 及 (EU) 2015/863 關於 RoHS 之規範要求。

Innodisk Corporation declares that all products sold to the company, are complied with European Union RoHS Directive (2011/65/EU) and (EU) 2015/863 requirement.

- 二、 本公司同意因本保證書或與本保證書相關事宜有所爭議時，雙方宜友好協商，達成協議。

Innodisk Corporation agrees that both parties shall settle any dispute arising from or in connection with this Declaration of Conformity by friendly negotiations.

Name of hazardous substance	Limited of RoHS ppm (mg/kg)
鉛 (Pb)	< 1000 ppm
汞 (Hg)	< 1000 ppm
鎘 (Cd)	< 100 ppm
六價鉻 (Cr 6+)	< 1000 ppm
多溴聯苯 (PBBs)	< 1000 ppm
多溴二苯醚 (PBDEs)	< 1000 ppm
鄰苯二甲酸二(2-乙基己基)酯 (DEHP)	< 1000 ppm
鄰苯二甲酸丁酯苯甲酯 (BBP)	< 1000 ppm
鄰苯二甲酸二丁酯 (DBP)	< 1000 ppm
鄰苯二甲酸二異丁酯 (DIBP)	< 1000 ppm

立 保 證 書 人 (Guarantor)

Company name 公司名稱：Innodisk Corporation 宜鼎國際股份有限公司

Company Representative 公司代表人：Randy Chien 簡川勝

Company Representative Title 公司代表人職稱：Chairman 董事長

Date 日期：2018 / 07 / 01



MSL

MSL Declaration of Conformity

1. Purpose: MSL (Moisture Sensitivity Levels) specification statement for all Innodisk products

2. Scope: For All Innodisk finish goods

3. Responsibilities: QA

4. Reference:

4.1 JEDEC, S-STD-020

4.2 JEDEC, J-STD-033

5. Description

5.1 Innodisk Products Level: All Innodisk products meet MSL Level 1

5.2 Floor Life Time: Refer following table

Level	Soak Requirements					
	Floor Life		Standard		Accelerated	
	Time	Cond degC/%RH	Time (hrs)	Cond degC/%RH	Time (hrs)	Cond degC/%RH
1	unlimited	<=30/85%	168+5/-0	85/85	n/a	n/a
2	1 year	<=30/60%	168+5/-0	85/60	n/a	n/a
2a	4 weeks	<=30/60%	696+5/-0	30/60	120+1/-0	60/60
3	168 hours	<=30/60%	192+5/-0	30/60	40+1/-0	60/60
4	72 hours	<=30/60%	96+2/-0	30/60	20+0.5/-0	60/60
5	48 hours	<=30/60%	72+2/-0	30/60	15+0.5/-0	60/60
5a	24 hours	<=30/60%	48+2/-0	30/60	10+0.5/-0	60/60
6	TOL	<=30/60%	TOL	30/60	n/a	60/60

**Innodisk Corporation
Quality Assurance Div
Manager
Yi Chuan Chen
Date: 2018.09.21**



數位簽署者: Yi Chuan Chen
DN: cn=Yi Chuan Chen, o=Innodisk Corporation, ou=QA Div, email=yichuan_chen@innodisk.com, c=TW
日期: 2018.09.21 13:39:10 +08'00'

CE(EN55022/EN55024)



VERIFICATION OF COMPLIANCE

This Verification of Compliance is hereby issued to the below named company. The test results of this report relate only to the tested sample identified in this report.

**Technical Standard: EMC DIRECTIVE 2014/30/EU
(EN55022 / EN55024)**

General Information

Applicant: Innodisk Corporation
5F., No. 237, Sec. 1, Datong Rd., Xizhi Dist.,
New Taipei City 22161, Taiwan (R.O.C)

Product Description

EUT Description: M.2
Brand Name: Innodisk
Model Number: M.2 (S42) 35*#-&
\$:Flash type: (S:SLC, I:iSLC, M:MLC, T:3D TLC)
*:Product line: (E:Embedded, G:EverGreen, R:InnoRobust)
#:Product Generation: (empty, 0-9)
&:Product line: (empty, P:Plus)

Measurement Standard

EN 55022: 2010 / AC: 2011
EN 61000-3-2: 2014
EN 61000-3-3: 2013
EN 55024: 2010 + A1: 2013
(IEC 61000-4-2: 2008; IEC 61000-4-3: 2006 + A1: 2007 + A2: 2010; IEC 61000-4-4: 2012;
IEC 61000-4-5: 2014; IEC 61000-4-6: 2013; IEC 61000-4-8: 2009; IEC 61000-4-11: 2004)

Measurement Facilities

Xindian Lab: Compliance Certification Services Inc.
No.163-1, Zhongsheng Rd., Xindian Dist., New Taipei City, 23151 Taiwan.
Tel: +886-2-22170894 / Fax: +886-2-22171029

This device has been shown to be in compliance with and was tested in accordance with the measurement procedures specified in the Standards & Specifications listed above and as indicated in the measurement report number: T161004D11-E

Sam Hu / Assistant Manager

Date: October 11, 2016



CE(EN55032)**VERIFICATION OF COMPLIANCE**

This Verification of Compliance is hereby issued to the below named company. The test results of this report relate only to the tested sample identified in this report.

**Technical Standard: EMC DIRECTIVE 2014/30/EU
(EN55032)**

General Information

Applicant: Innodisk Corporation
5F., No. 237, Sec. 1, Datong Rd., Xizhi Dist.,
New Taipei City 22161, Taiwan (R.O.C)

Product Description

EUT Description: M.2
Brand Name: Innodisk
Model Number: M.2 (S42) 3S*#-&
S:Flash type: (S:SLC, I:ISLC, M:MLC, T:3D TLC)
*:Product line: (E:Embedded, G:EverGreen, R:InnoRobust)
#:Product Generation: (empty, 0-9)
&:Product line: (empty, P:Plus)

Measurement Standard

EN 55032: 2012 / AC: 2013
CISPR 32: 2012

Measurement Facilities

Xindian Lab: Compliance Certification Services Inc.
No.163-1, Zhongsheng Rd., Xindian Dist., New Taipei City, 23151 Taiwan.
Tel: +886-2-22170894 / Fax: +886-2-22171029

This device has been shown to be in compliance with and was tested in accordance with the measurement procedures specified in the Standards & Specifications listed above and as indicated in the measurement report number: T161004D11-E

Sam Hu / Assistant Manager
Date: October 11, 2016



FCC



VERIFICATION OF COMPLIANCE

This Verification of Compliance is hereby issued to the below named company. The test results of this report relate only to the tested sample identified in this report.

**Technical Standard: FCC Part 15 Class B
IC ICES-003**

General Information

Applicant: Innodisk Corporation
5F., No. 237, Sec. 1, Datong Rd., Xizhi Dist.,
New Taipei City 22161, Taiwan (R.O.C)

Product Description

EUT Description: M.2
Brand Name: Innodisk
Model Number: M.2 (S42) 3\$*#-&
\$:Flash type: (S:SLC, I:iSLC, M:MLC, T:3D TLC)
*:Product line: (E:Embedded, G:EverGreen, R:InnoRobust)
#:Product Generation: (empty, 0-9)
&:Product line: (empty, P:Plus)

Measurement Facilities

Xindian Lab.: **Compliance Certification Services Inc.**
No.163-1, Zhongsheng Rd., Xindian Dist., New Taipei City, 23151 Taiwan.
Tel: +886-2-22170894 / Fax: +886-2-22171029

This device has been shown to be in compliance with and was tested in accordance with the measurement procedures specified in the Standards & Specifications listed above and as indicated in the measurement report number: T161004D14-E

Sam Hu / Assistant Manager

Date: October 11, 2016

