

Approval Sheet

Customer	
Product Number	M5SZ-BGM2OC0Q-D
Data Rate	5600 MT/s
Pin	262 pin
CI-tRCD-tRP	46-45-45
Operating temperature	Tc=0 to 95°C
Date	17th October 2023

**The Total Solution For
Industrial Flash Storage**

Rev 1.0

1. Features

- JEDEC Standard 262-pin Small Outline Dual In-Line Memory Module
- VDD=VDDQ= 1.1V (1.067V ~ 1.166V)
- VPP=1.8V (1.746V ~ 1.908V)
- VDDSPD= 1.8V
- On-die, internal, adjustable VREF generation for DQ,CA,CS
- 16n-bit prefetch
- Two independent I/O sub channels
- Programmable /CAS Latency: 22,26,28,30,32,36,40,42,46,50
- tREFI 3.9us for 0°C ≤Tcase < 85°C, tREFI 1.95us for 85°C < Tcase ≤ 95°C
- On-Die ECC
- PMIC on DIMM, nominal supply 5V, VIN_Bulk input supply range: 4.25 V to 5.5 V
- Fly-by topology
- I3C/I2C support
- Terminated control and C/A bus
- SPD EEPROM Hub and Integrated Thermal Sensor
- Halogen-free

Specification							
Density	Data Rate	IC Configuration	DIMM Organization	Number of IC	Number of rank	Side	ECC
32GB	5600 MT/s	2Gx8 (16Gb)	4Gx64	16	2	2	N

Key timing parameters				
tCK (ns)	tRCD (ns)	tRP (ns)	tRAS (ns)	tRC (ns)
0.357	16.00	16.00	32	48.00

tRFC parameter by IC Configuration					
Parameter	IC Configuration				Unit
	8Gb	16Gb	24Gb	32Gb	
tRFC1,min	195	295	TBD	TBD	ns
tRFC2,min	130	160	TBD	TBD	ns
tRFCsb,min	115	130	TBD	TBD	ns

2. Pin Assignments

262-Pin DDR5 SODIMM Front								262-Pin DDR5 SODIMM Back							
Pin	Symbol	Pin	Symbol	Pin	Symbol	Pin	Symbol	Pin	Symbol	Pin	Symbol	Pin	Symbol	Pin	Symbol
1	VIN_BULK	67	Vss	133	CK0_A_c	199	DQ8_B	2	HAS	68	DQ21_A	134	CK1_A_c	200	Vss
3	VIN_BULK	69	DQ22_A	135	Vss	201	Vss	4	HSCL	70	Vss	136	Vss	202	DQ9_B
5	RFU	71	Vss	137	CK0_B_t	203	DQ10_B	6	HSDA	72	DQ23_A	138	CK1_B_t	204	Vss
7	PWR_GOOD	73	DQ24_A	139	CK0_B_c	205	Vss	8	PWR_EN	74	Vss	140	CK1_B_c	206	DQ11_B
9	Vss	75	Vss	141	Vss	207	DQS1_B_c	10	Vss	76	DQ25_A	142	Vss	208	Vss
11	DQ0_A	77	DQ26_A	143	RFU	209	DQS1_B_t	12	DQ1_A	78	Vss	144	CA12_B	210	DM1_B_n
13	Vss	79	Vss	145	CA11_B	211	Vss	14	Vss	80	DQ27_A	146	CA10_B	212	Vss
15	DQ2_A	81	DQS3_A_c	147	Vss	213	DQ12_B	16	DQ3_A	82	Vss	148	Vss	214	DQ13_B
17	Vss	83	DQS3_A_t	149	CA9_B	215	Vss	18	Vss	84	DM3_A_n	150	CA8_B	216	Vss
19	DM0_A_n	85	Vss	151	CA7_B	217	DQ14_B	20	DQS0_A_c	86	Vss	152	CA6_B	218	DQ15_B
21	Vss	87	DQ28_A	153	Vss	219	Vss	22	DQS0_A_t	88	DQ29_A	154	Vss	220	Vss
23	DQ4_A	89	Vss	155	CA5_B	221	DQ16_B	24	Vss	90	Vss	156	CA4_B	222	DQ17_B
25	Vss	91	DQ30_A	157	CA3_B	223	Vss	26	DQ5_A	92	DQ31_A	158	CA2_B	224	Vss
27	DQ6_A	93	Vss	159	Vss	225	DQ18_B	28	Vss	94	Vss	160	Vss	226	DQ19_B
29	Vss	95	CB0_A	161	CS0_B_n	227	Vss	30	DQ7_A	96	CB1_A	162	CA1_B	228	Vss
31	DQ8_A	97	Vss	163	RESET_n	229	DM2_B_n	32	Vss	98	Vss	164	CA0_B	230	DQS2_B_c
33	Vss	99	CB2_A	165	CS1_B_n	231	Vss	34	DQ9_A	100	DQS4_A_c	166	Vss	232	DQS2_B_t
35	DQ10_A	101	Vss	167	Vss	233	DQ20_B	36	Vss	102	DQS4_A_t	168	CB0_B	234	Vss
37	Vss	103	CB3_A	169	DQS4_B_c	235	Vss	38	DQ11_A	104	Vss	170	Vss	236	DQ21_B
39	DQS1_A_c	105	Vss	171	DQS4_B_t	237	DQ22_B	40	Vss	106	CS0_A_n	172	CB1_B	238	Vss
41	DQS1_A_t	107	CA0_A	173	Vss	239	Vss	42	DM1_A_n	108	ALERT_n	174	Vss	240	DQ23_B
43	Vss	109	CA1_A	175	CB3_B	241	DQ24_B	44	Vss	110	CS1_A_n	176	CB2_B	242	Vss
45	DQ12_A	111	Vss	177	Vss	243	Vss	46	DQ13_A	112	Vss	178	Vss	244	DQ25_B
47	Vss	113	CA2_A	179	DQ0_B	245	DQ26_B	48	Vss	114	CA3_A	180	DQ1_B	246	Vss
49	DQ14_A	115	CA4_A	181	Vss	247	Vss	50	DQ_15_A	116	CA5_A	182	Vss	248	DQ27_B
51	Vss	117	Vss	183	DQ2_B	249	DQS3_B_c	52	Vss	118	Vss	184	DQ3_B	250	Vss
53	DQ16_A	119	CA6_A	185	Vss	251	DQS3_B_t	54	DQ17_A	120	CA7_A	186	Vss	252	DM3_B_n
55	Vss	121	CA8_A	187	DM0_B_n	253	Vss	56	Vss	122	CA9_A	188	DQS0_B_c	254	Vss
57	DQ18_A	123	Vss	189	Vss	255	DQ28_B	58	DQ19_A	124	Vss	190	DQS0_B_t	256	DQ29_B
59	Vss	125	CA10_A	191	DQ4_B	257	Vss	60	Vss	126	CA11_A	192	Vss	258	Vss
61	DM2_A_n	127	CA12_A	193	Vss	259	DQ30_B	62	DQS2_A_c	128	RFU	194	DQ5_B	260	DQ31_B
63	Vss	129	Vss	195	DQ6_B	261	Vss	64	DQS2_A_t	130	Vss	196	Vss	262	Vss
65	DQ20_A	131	CK0_A_t	197	Vss			66	Vss	132	CK1_A_t	198	DQ7_B		

3. Pin Descriptions

Symbol	Type	I/O Level	Description	Symbol	Type	I/O Level	Description
CK_t, CK_c	Input	VDDQ	Clock	DQ[31:0]_A DQ[31:0]_B	Input/ Output	VDDQ	Data Input/Output
CA[12:0]_A CA[12:0]_B	Input	VDDQ	Command/Address Inputs	CB[3:0]_A CB[3:0]_B	Input/ Output	VDDQ	ECC Check Bits Input/Output
CS[1:0]_A CS[1:0]_B	Input	VDDQ	Chip Select	DQS[4:0]_A_t DQS[4:0]_B_t	Input/ Output	VDDQ	Data Strobe
ALERT_n	Output	VDDQ	Alert	DQS[4:0]_A_c DQS[4:0]_B_c	Input/ Output	VDDQ	Data Strobe
RESET_n	CMOS Input	VDDQ	Active Low Asynchronous Reset	DM[3:0]_A_n DM[3:0]_B_n	Input	VDDQ	Input Data Mask
PWR_GOOD	Input/ Output	VDDQ	Power Good Indicator	VIN_BULK	Supply		External Power Supply
HSCL	Input	VOUT	Host Sideband Bus Clock	PWR_EN	Input		PMIC Enable
HSDA	Input/ Output	VOUT	Host Sideband Bus Data	VSS	Supply		Ground
HSA	Input	GND	Host Sideband Bus Device ID	RFU			Reserved for future use

4. Function Block Diagram

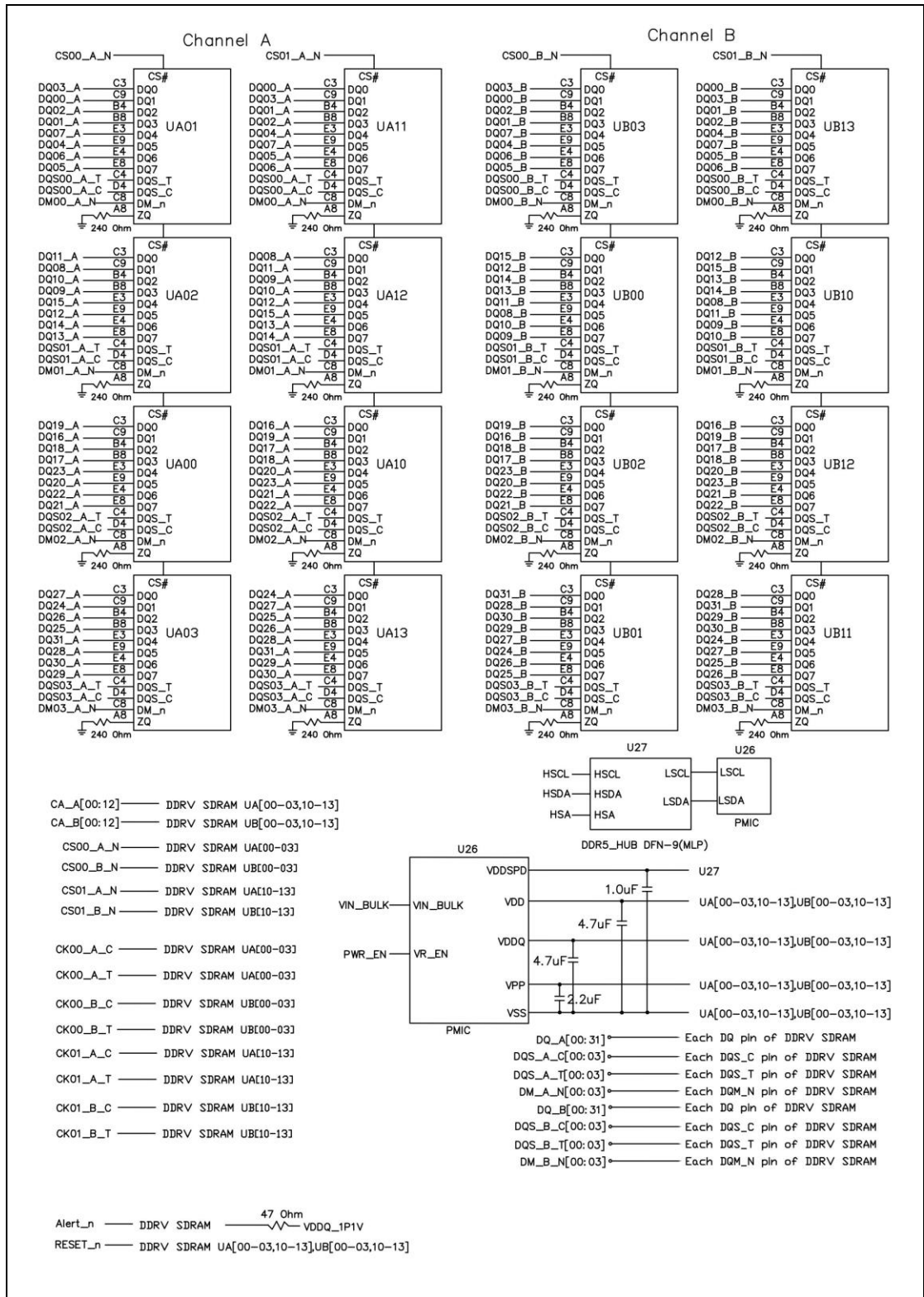

5. Thermal Characteristics

Symbol	Parameter		Rating	Units	Note
T _C	Operation Temperature	Normal Operating Temp.	0 to 95	°C	1,2,3,4
T _{STG}	Storage Temperature		-55 to 100	°C	5

Note:

1. Maximum operating case temperature; T_C is measured in the center of the package.
2. A thermal solution must be designed to ensure the DRAM device does not exceed the maximum T_C during operation.
3. Device functionality is not guaranteed if the DRAM device exceeds the maximum T_C during operation.
4. If T_C exceeds 85°C, the DRAM must be refreshed externally at 2X refresh, which is a 1.95μs interval refresh rate.
5. Storage temperature is defined as the temperature of the top/center of the DRAM and does not reflect the storage temperatures of shipping trays.

6. IDD, IDDQ and IPP Specifications

Symbol	Description	Value (Typical)		Units
		IDD Max.	IPP Max.	
IDD0	Operating One Bank Active-Precharge Current	816	128	mA
IDD0F	Operating Four Bank Active-Precharge Current	1112	144	mA
IDD2N	Precharge Standby Current	784	112	mA
IDD2P	Precharge Power-Down Current	752	112	mA
IDD3N	Active Standby Current	1776	128	mA
IDD3P	Active Power-Down Current	1760	128	mA
IDD4R	Operating Burst Read Current	2496	136	mA
IDD4W	Operating Burst Write Current	2544	240	mA
IDD5B	Burst Refresh Current (Normal Refresh Mode)	3848	320	mA
IDD5C	Burst Refresh Current (Same Bank Refresh Mode)	1576	168	mA
IDD6N	Self Refresh Current	1792	240	mA
IDD6E	Self Refresh Current: Extended Temperature Range	2976	320	mA
IDD7	Operating Bank Interleave Read Current	3480	248	mA
IDD8	Maximum Power Saving Deep Power Down Current	672	112	mA

The above information may be change due to the update of the device specifications and is for reference only.

7. Timing Parameters

Parameter	Symbol	5600		6000		6400		Unit
		Min	Max	Min	Max	Min	Max	
Clock Timing								
Average clock period	tCK,AVG	0.357		0.333		0.312		ns
Command and Address Timing								
Read to Read command delay for same bank group	tCCD_L	8nCK,5ns (MAX)		8nCK,5ns (MAX)		8nCK,5ns (MAX)		nCK
WRITE to WRITE command delay for same bank group	tCCD_L_WR	32nCK, 20ns (MAX)		32nCK, 20ns (MAX)		32nCK, 20ns (MAX)		nCK
WRITE to WRITE command delay for same bank group, second WRITE not RMW	tCCD_L_WR2	16nCK, 10ns (MAX)		16nCK, 10ns (MAX)		16nCK, 10ns (MAX)		nCK
Read to Read or Write to Write command delay for different bank group for BL16, BC8 OTF	tCCD_S	8		8		8		nCK
ACTIVATE to ACTIVATE command delay to different bank group for 2KB page size	tRRD_S,2K	8		8		8		nCK
ACTIVATE to ACTIVATE command delay to different bank group for 1KB page size	tRRD_S,1K	8		8		8		nCK
ACTIVATE to ACTIVATE command delay to same bank group for 2KB page size	tRRD_L,2K	8nCK,5ns (MAX)		8nCK,5ns (MAX)		8nCK,5ns (MAX)		nCK
ACTIVATE to ACTIVATE command delay to same bank group for 1KB page size	tRRD_L,1K	8nCK,5ns (MAX)		8nCK,5ns (MAX)		8nCK,5ns (MAX)		nCK
Four activate window for	tFAW,2K	40nCK,		40nCK,		40nCK,		ns

2KB page size		14.280ns (MAX)		13.333ns (MAX)		12.500ns (MAX)		
Four activate window for 1KB page size	tFAW,1K	32nCK, 11.428ns (MAX)		32nCK, 10.666ns (MAX)		32nCK, 10.000ns (MAX)		ns
Delay from start of internal WRITE transaction to internal READ command for different bank group	tWTR_S	2.5		2.5		2.5		ns
Delay from start of internal WRITE transaction to internal READ command for same bank group	tWTR_L	10		10		10		ns
Delay from start of internal WRITE transaction to internal READ with AUTO PRECHARGE command for same bank	tWTRA	tWR-tRTP		tWR-tRTP		tWR-tRTP		ns
Internal READ command to PRECHARGE command delay	tRTP	7.5		7.5		7.5		ns
PRECHARGE to PRECHARGE delay	tPPD	2		2		2		nCK
WRITE recovery time	tWR	30		30		30		ns

8. Module Dimensions

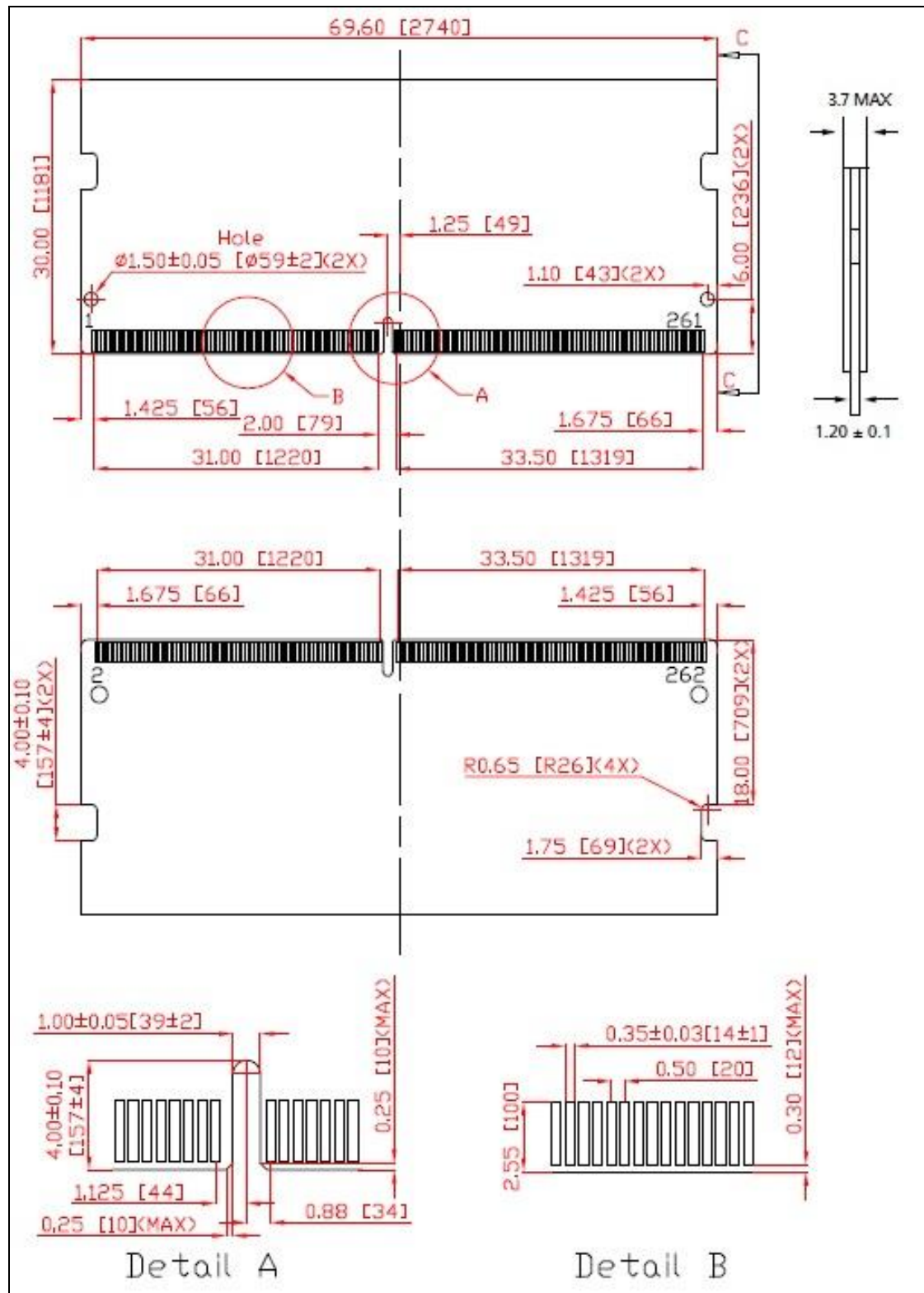

Note: All dimensions are in millimeters (mils) and should be kept within a tolerance of ±0.15 (6), unless otherwise specified.

9. RoHS Declaration

innodisk	宜鼎國際股份有限公司 Innodisk Corporation	Page 1/2
Tel:(02)7703-3000 Internet: https://www.innodisk.com/		
RoHS 自我宣告書 (RoHS Declaration of Conformity)		
Manufacturer Products: All Innodisk EM FLASH, DRAM and EP products		
<p>一、 宜鼎國際股份有限公司（以下稱本公司）特此保證售予貴公司之所有產品，皆符合歐盟 2011/65/EU 及 (EU) 2015/863 關於 RoHS 之規範要求。 Innodisk Corporation declares that all products sold to the company, are complied with European Union RoHS Directive (2011/65/EU) and (EU) 2015/863 requirement.</p>		
<p>二、 本公司同意因本保證書或與本保證書相關事宜有所爭議時，雙方宜友好協商，達成協議。 Innodisk Corporation agrees that both parties shall settle any dispute arising from or in connection with this Declaration of Conformity by friendly negotiations.</p>		
<p>三、 本公司聲明我們的產品符合 RoHS 指令的附件中 7(a)、7(c)-I、6(c) 允許豁免。 We declare, our products permitted by the following exemptions specified in the Annex of the RoHS directive.</p>		
<p>※ 7(a) Lead in high melting temperature type solders (i. e. lead-based alloys containing 85% by weight or more lead).</p>		
<p>※ 7(c)-I Electrical and electronic components containing lead in a glass or ceramic other than dielectric ceramic in capacitors, e.g. piezoelectric devices, or in a glass or ceramic matrix compound.</p>		
<p>※ 6(c) Copper alloy containing up to 4% lead by weight. (This exemption applies to products that use antennas)</p>		
Name of hazardous substance	Limited of RoHS ppm (mg/kg)	
鉛 (Pb)	< 1000 ppm	
汞 (Hg)	< 1000 ppm	
鎘 (Cd)	< 100 ppm	
六價鉻 (Cr 6+)	< 1000 ppm	
多溴聯苯 (PBBs)	< 1000 ppm	
多溴二苯醚 (PBDEs)	< 1000 ppm	
鄰苯二甲酸二(2-乙基己基)酯 (DEHP)	< 1000 ppm	
鄰苯二甲酸丁酯苯甲酯 (BBP)	< 1000 ppm	
鄰苯二甲酸二丁酯 (DBP)	< 1000 ppm	

innodisk

宜鼎國際股份有限公司
Innodisk Corporation



Page 2/2

鄰苯二甲酸二異丁酯 (DIBP)	< 1000 ppm
------------------	------------

立 保 證 書 人 (Guarantor)

Company name 公司名稱： Innodisk Corporation 宜鼎國際股份有限公司Company Representative 公司代表人： Randy Chien 簡川勝Company Representative Title 公司代表人職稱： Chairman 董事長Date 日期： 2021 / 06 / 09

10. REACH Declaration

	<p style="text-align: center;">宜鼎國際股份有限公司 Innodisk Corporation REACH Declaration</p>
<p style="text-align: right;">Tel:(02)7703-3000 Fax:(02) 7703-3555 Internet: https://www.innodisk.com/</p>	
<p>Innodisk Corporation pursues its social responsibility for global environmental preservation by committing to be compliant with REACH regulation (REGULATION (EC) No 1907/2006).</p>	
<p>We hereby confirm that the product(s),</p>	
<p>Scope: Flash Memory, DRAM Module and Embedded Peripherals Products.</p>	
<p>■ The standard products of not listed in the <u>Appendix2</u> meet the requirements of REACH SVHC regulations(SVHCs < 0.1% in Article), as described in the candidate list table currently including 224 substances and shown on the ECHA website. (http://echa.europa.eu/de/candidate-list-table).</p>	
<p>■ The standard products listed in the <u>Appendix2</u> contain(s) one or more hazardous substances or constituents exceeding 0.1 % by weight in article if not otherwise specified in candidate list table. Where the threshold value is exceeded, the substances in question are to be declared in accompanying. (SVHCs > 0.1% in Article).</p>	
<p>■ Comply with REACH Annex XVII.</p>	
<p>Guarantor</p>	
<p>Company name 公司名稱： <u>Innodisk Corporation 宜鼎國際股份有限公司</u></p>	
<p>Company Representative 公司代表人： <u> 陳怡全</u></p>	
<p>Company Representative Title 公司代表人職稱： <u>QA Manager 品保經理</u></p>	
<p>Date 日期： <u>2022 / 06 / 14</u></p>	
	

Revision Log

Rev	Date	Modification
0.1	17 th October 2023	Preliminary Edition
1.0	17 th October 2023	Official released