

ESM-QM77

Intel QM77 COM Express Type 6 Module

User's Manual

1st Ed – 29 January 2013

Notice

This guide is designed for experienced users to perform quick setup of the system. For detailed information, please always refer to the electronic user's manual.

Copyright Notice

Copyright © 2013 ALL RIGHTS RESERVED.

Part No. E2047286200R

FCC Statement



THIS DEVICE COMPLIES WITH PART 15 FCC RULES. OPERATION IS SUBJECT TO THE FOLLOWING TWO CONDITIONS:

(1) THIS DEVICE MAY NOT CAUSE HARMFUL INTERFERENCE.

(2) THIS DEVICE MUST ACCEPT ANY INTERFERENCE RECEIVED INCLUDING INTERFERENCE THAT MAY CAUSE UNDESIRE OPERATION.

THIS EQUIPMENT HAS BEEN TESTED AND FOUND TO COMPLY WITH THE LIMITS FOR A CLASS "A" DIGITAL DEVICE, PURSUANT TO PART 15 OF THE FCC RULES.

THESE LIMITS ARE DESIGNED TO PROVIDE REASONABLE PROTECTION AGAINST HARMFUL INTERFERENCE WHEN THE EQUIPMENT IS OPERATED IN A COMMERCIAL ENVIRONMENT. THIS EQUIPMENT GENERATES, USES, AND CAN RADIATE RADIO FREQUENCY ENERGY AND, IF NOT INSTALLED AND USED IN ACCORDANCE WITH THE INSTRUCTION MANUAL, MAY CAUSE HARMFUL INTERFERENCE TO RADIO COMMUNICATIONS.

OPERATION OF THIS EQUIPMENT IN A RESIDENTIAL AREA IS LIKELY TO CAUSE HARMFUL INTERFERENCE IN WHICH CASE THE USER WILL BE REQUIRED TO CORRECT THE INTERFERENCE AT HIS OWN EXPENSE.

Notice

This guide is designed for experienced users to setup the system within the shortest time. For detailed information, please always refer to the electronic user's manual.

Copyright Notice

Copyright © 2013 ALL RIGHTS RESERVED.

No part of this document may be reproduced, copied, translated, or transmitted in any form or by any means, electronic or mechanical, for any purpose, without the prior written permission of the original manufacturer.

A Message to the customer

Customer Services

Each and every product is built to the most exacting specifications to ensure reliable performance in the harsh and demanding conditions typical of industrial environments. Whether your new device is destined for the laboratory or the factory floor, you can be assured that your product will provide the reliability and ease of operation.

Your satisfaction is our primary concern. Here is a guide to our customer services. To ensure you get the full benefit of our services, please follow the instructions below carefully.

Technical Support

We want you to get the maximum performance from your products. So if you run into technical difficulties, we are here to help. For the most frequently asked questions, you can easily find answers in your product documentation. These answers are normally a lot more detailed than the ones we can give over the phone. So please consult the user's manual first.

CONTENT

1. Getting Started	7
1.1 Safety Precautions	7
1.2 Packing List	7
1.3 Document Amendment History	8
1.4 Manual Objectives	9
1.5 System Specifications	10
1.6 Architecture Overview—Block Diagram	11
2. Hardware Configuration	12
2.1 Product Overview	13
2.2 Installation Procedure	15
2.2.1 Main Memory	16
2.3 Connector List	18
2.4 Setting Jumpers & Connectors	19
2.4.1 AT/ATX mode selector (SW1)	19
2.4.1.1 Signal Description –AT/ATX mode selection	19
2.4.2 COM Express Connector 1 (CN1A)	20
2.4.2.1 Signal Description – COM Express Connector 1 (CN1A)	24
2.4.2.1.1 Audio Signals	24
2.4.2.1.2 Gigabit Ethernet Signals	24
2.4.2.1.3 GPIO Signals	24
2.4.2.1.4 LPC Signals	25
2.4.2.1.5 Miscellaneous Signals	25
2.4.2.1.6 PCI Express Signals	25
2.4.2.1.7 Power Signals	26
2.4.2.1.8 Power & System Management Signals	26
2.4.2.1.9 SATA Signals	26
2.4.2.1.10 VGA Signals	27
2.4.2.1.11 USB Signals	27
2.4.2.1.12 LVDS Flat Panel Signals	27
2.4.3 COM Express Connector 2 (CN1B)	28
2.4.3.1 Signal Description – COM Express Connector 2 (CN1B)	32
2.4.3.1.1 USB Signals	32
2.4.3.1.2 PEG Signals	32
2.4.3.1.3 DDI Signals	32

2.5	Intel HD Graphics – 3 Active Displays Support	33
3	BIOS Setup	34
3.1	Introduction	35
3.2	Starting Setup	35
3.3	Using Setup.....	36
3.4	Getting Help	37
3.5	In Case of Problems	37
3.6	BIOS setup.....	38
3.6.1	Main Menu.....	38
3.6.1.1	System Language	39
3.6.1.2	System Date.....	39
3.6.1.3	System Time	39
3.6.2	Advanced Menu.....	39
3.6.2.1	APCI Settings.....	40
3.6.2.2	S5 RTC Wake Settings	40
3.6.2.3	Trusted Computing.....	41
3.6.2.4	CPU Configuration	42
3.6.2.5	SATA Configuration.....	43
3.6.2.6	Thermal Configuration.....	44
3.6.2.6.1	Platform Thermal Configuration	44
3.6.2.7	Intel® Rapid Start Technology.....	46
3.6.2.8	Intel® TXT(LT) Configuration	47
3.6.2.9	PCH-FW Configuration.....	47
3.6.2.9.1	Firmware Update Configuration	48
3.6.2.10	Intel® Anti- Theft Technology Configuration.....	48
3.6.2.11	AMT Configuration	49
3.6.2.12	USB Configuration.....	50
3.6.2.13	H/W Monitor2	51
3.6.2.14	Super IO Configuration.....	51
3.6.2.14.1	Serial Port 1 Configuration.....	52
3.6.2.14.2	Serial Port 2 Configuration.....	53
3.6.2.14.3	Parallel Port Configuration.....	54
3.6.2.15	Intel® Smart Connect Technology.....	55
3.6.2.16	CPU PPM Configuration.....	55
3.6.3	Chipset.....	56
3.6.3.1	PCH-IO Configuration.....	57
3.6.3.1.1	PCI Express Configuration.....	58
3.6.3.1.2	USB Configuration	63
3.6.3.1.3	PCH Azalia Configuration	64
3.6.3.2	System Agent (SA) Configuration.....	65

ESM-QM77	
3.6.3.2.1	Memory Configuration..... 66
3.6.3.2.2	GT – Power Management Configuration..... 66
3.6.3.3	Graphics Configuration..... 67
3.6.4	Boot..... 69
3.6.4.1	CSM parameters..... 71
3.6.5	Security..... 72
3.6.6	Save and exit..... 73
3.6.6.1	Save Changes and Exit..... 73
3.6.6.2	Discard Changes and Exit..... 73
3.6.6.3	Save Changes and Reset..... 74
3.6.6.4	Discard Changes and Reset..... 74
3.6.6.5	Save Changes..... 74
3.6.6.6	Discard Changes..... 74
3.6.6.7	Restore Defaults..... 74
3.6.6.8	Save as User Defaults..... 74
3.6.6.9	Restore User Defaults..... 74
3.6.6.10	Launch EFI Shell from filesystem device..... 74
4. Drivers Installation.....	75
4.1	Install Chipset Driver (For Intel QM77).....76
4.2	Install Display Driver (For Intel QM77).....77
4.3	Install LAN Driver (For Intel 82579).....79
4.4	Install USB 3.0 Driver (For Intel QM77).....81
4.5	Install ME Driver (For Intel QM77).....82
5. Mechanical Drawing	84

1. Getting Started

1.1 Safety Precautions

Warning!



Always completely disconnect the power cord from your chassis whenever you work with the hardware. Do not make connections while the power is on. Sensitive electronic components can be damaged by sudden power surges. Only experienced electronics personnel should open the PC chassis.

Caution!



Always ground yourself to remove any static charge before touching the CPU card. Modern electronic devices are very sensitive to static electric charges. As a safety precaution, use a grounding wrist strap at all times. Place all electronic components in a static-dissipative surface or static-shielded bag when they are not in the chassis.

1.2 Packing List

Before you begin installing your single board, please make sure that the following materials have been shipped:

- 1 x ESM-QM77 Intel Core i7 / i5 / i3 Celeron COM Express Module
- 1 x Quick Installation Guide
- 1 x DVD-ROM contains the followings:
 - User's Manual (this manual in PDF file)
 - Chipset and Ethernet driver



If any of the above items is damaged or missing, contact your retailer.

1.3 Document Amendment History

Revision	Date	By	Comment
1st	January 2013		Initial Release

1.4 Manual Objectives

This manual describes in details ESM-QM77 Single Board.

We have tried to include as much information as possible but we have not duplicated information that is provided in the standard IBM Technical References, unless it proved to be necessary to aid in the understanding of this board.

We strongly recommend that you study this manual carefully before attempting to set up ESM-QM77 series or change the standard configurations. Whilst all the necessary information is available in this manual we would recommend that unless you are confident, you contact your supplier for guidance.

Please be aware that it is possible to create configurations within the CMOS RAM that make booting impossible. If this should happen, clear the CMOS settings, (see the description of the Jumper Settings for details).

If you have any suggestions or find any errors regarding this manual and want to inform us of these, please contact our Customer Service department with the relevant details.

1.5 System Specifications

System	
CPU	Intel Core i7/i5/i3/Celeron (Socket-G2) Processors
BIOS	AMI 64M-bit SPI BIOS
System Chipset	Intel QM77 Chipset
System Memory	Two 204-pin DDR3 SODIMM socket, supports up to 16GB DDR3 1333/1600 SDRAM
Expansion	7 PCIe x1, 1 PCIe x16
EEPROM	ATMEL AT24C02 (Optional)
I/O	
MIO	4 x Serial ATA, SMBus/ I2C Bus
USB	8 x USB 2.0, 4 x USB3.0
DIO	4-bit GPI, 4-bit GPO
Display	
Chipset	Intel QM77 Chipset Integrated
Memory	DVMT 5.0 up to 512MB
Resolution	CRT Mode: 2048 x 1536 LCD/ Simultaneous Mode: 1920 x 1200
LVDS	Dual channel 18/24-bit LVDS
Display Supported	HDMI, DVI, Display Port
Audio	
Chipset	Intel QM77
Interface	Intel High Definition Audio
Ethernet	
LAN Chip	Intel 82579LM
Ethernet Interface	10/100/1000 Base-Tx Gigabit Ethernet Compatible
Mechanical & Environmental	
Power Requirement	+9V ~ +19V
ACPI	Single power ATX Support S0, S3, S4, S5 ACPI 3.0 Compliant
Power Type	AT/ATX
Operating Temp.	0 to 60°C
Storage Temp.	-40~-75°C
Operating Humidity	0%~90% relative humidity, non-condensing
Size (L x W)	125 mm x 95 mm
Weight	0.44lbs(0.2kg)

1.6 Architecture Overview—Block Diagram

The following block diagram shows the architecture and main components of ESM-QM77.

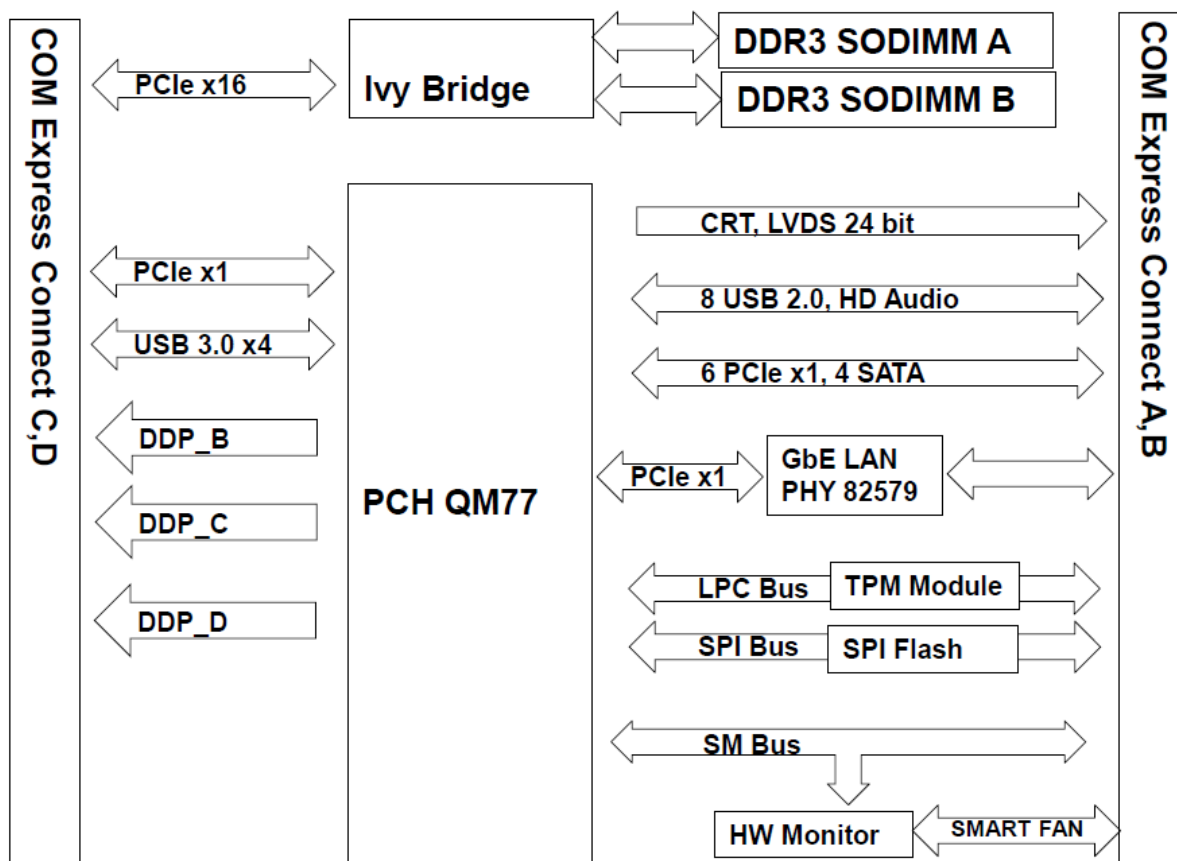

2. Hardware Configuration

2.1 Product Overview

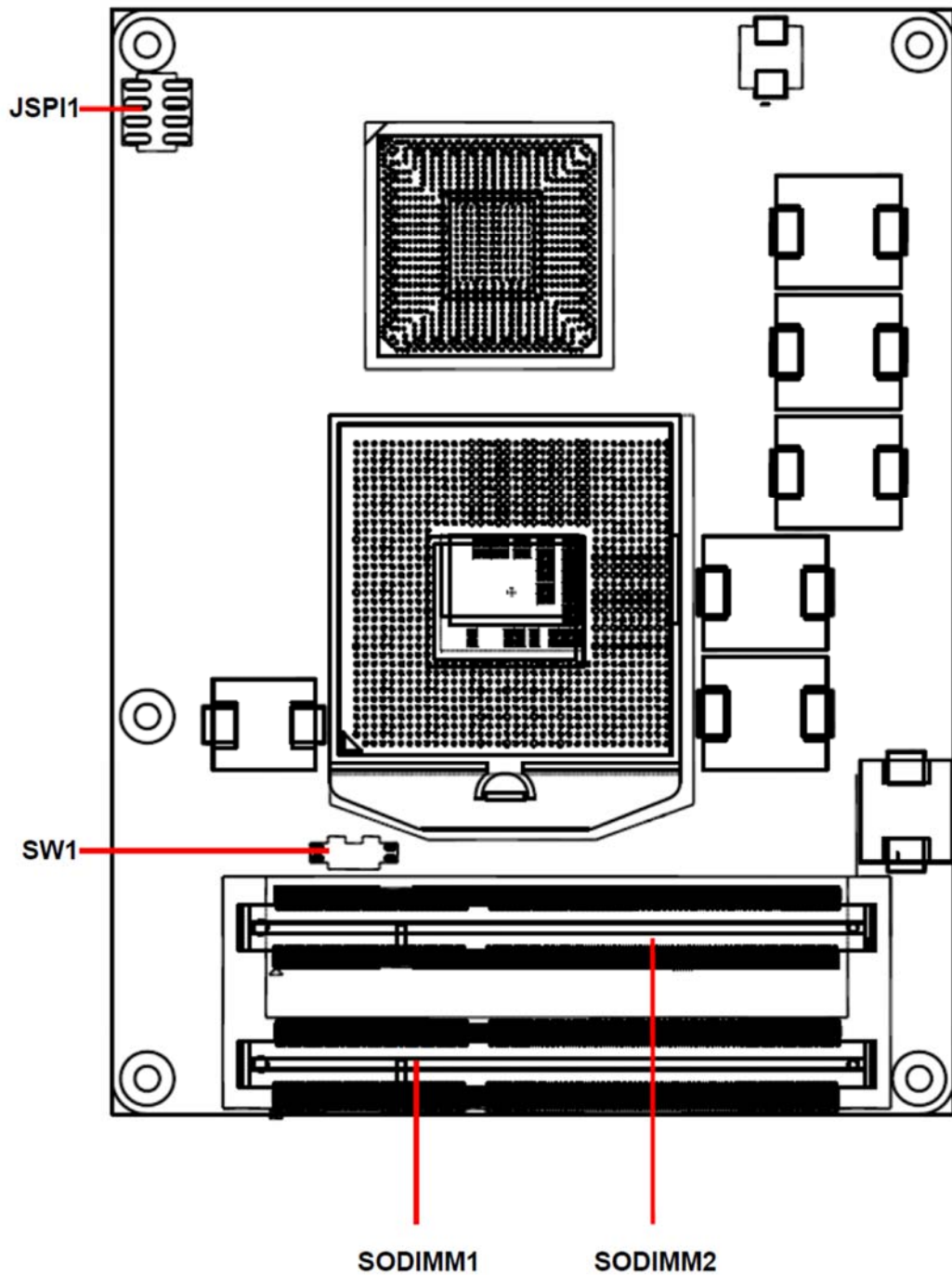

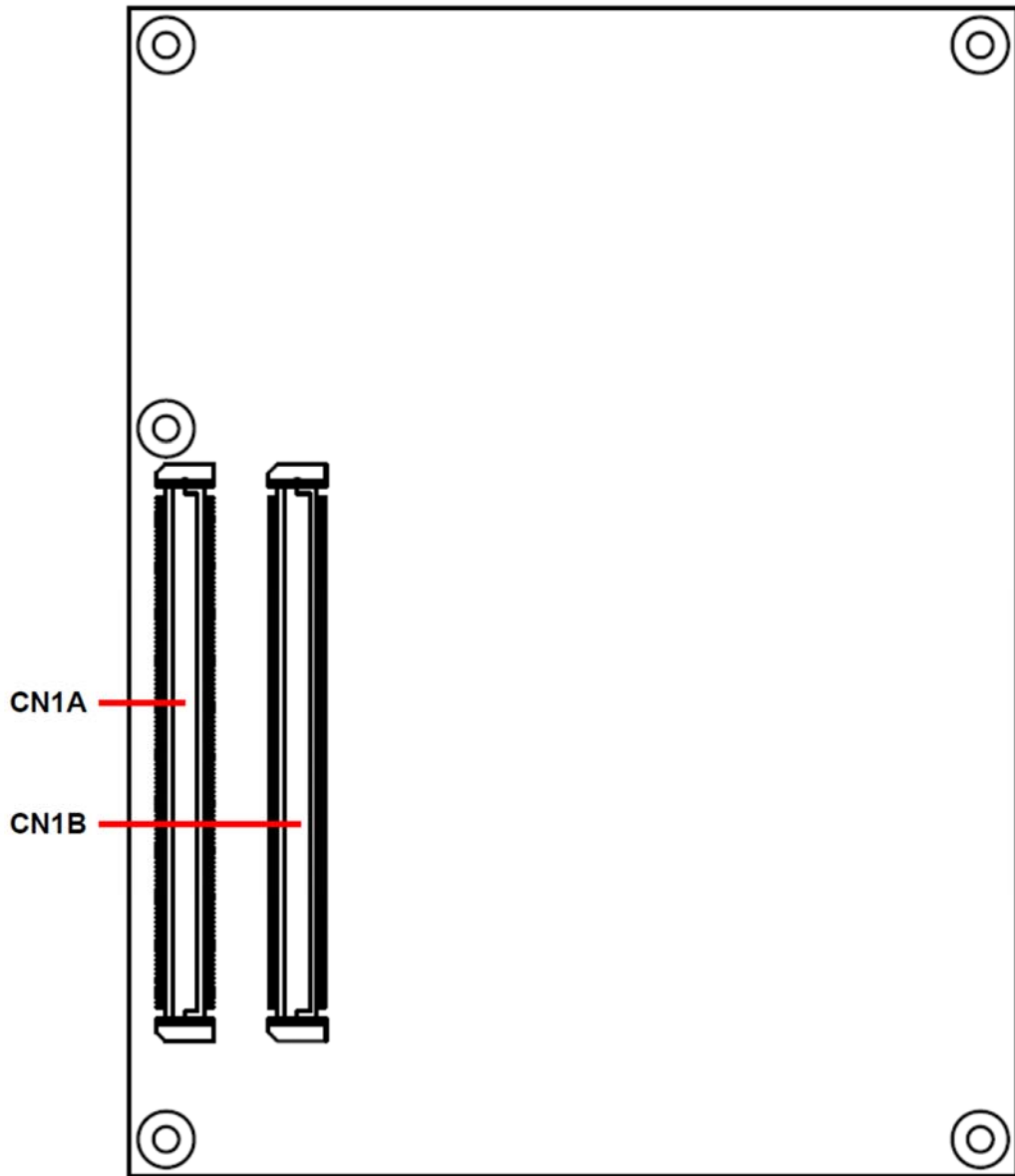

2.2 Installation Procedure

This chapter explains you the instructions of how to setup your system.

1. Turn off the power supply.
2. Insert the DIMM module (be careful with the orientation).
3. Insert all external cables for hard disk, floppy, keyboard, mouse, USB etc. except for flat panel. A CRT monitor must be connected in order to change CMOS settings to support flat panel.
4. Connect power supply to the board via the ATXPWR.
5. Turn on the power.
6. Enter the BIOS setup by pressing the delete key during boot up. Use the "Save & Exit \ Restore Defaults" feature.
7. If TFT panel display is to be utilized, make sure the panel voltage is correctly set before connecting the display cable and turning on the power.

ESM-QM77

2.2.1 Main Memory

ESM-QM77 provides two 204-pin DDR3 SODIMM socket, supports up to 16GB DDR3 1333/1600 SDRAM

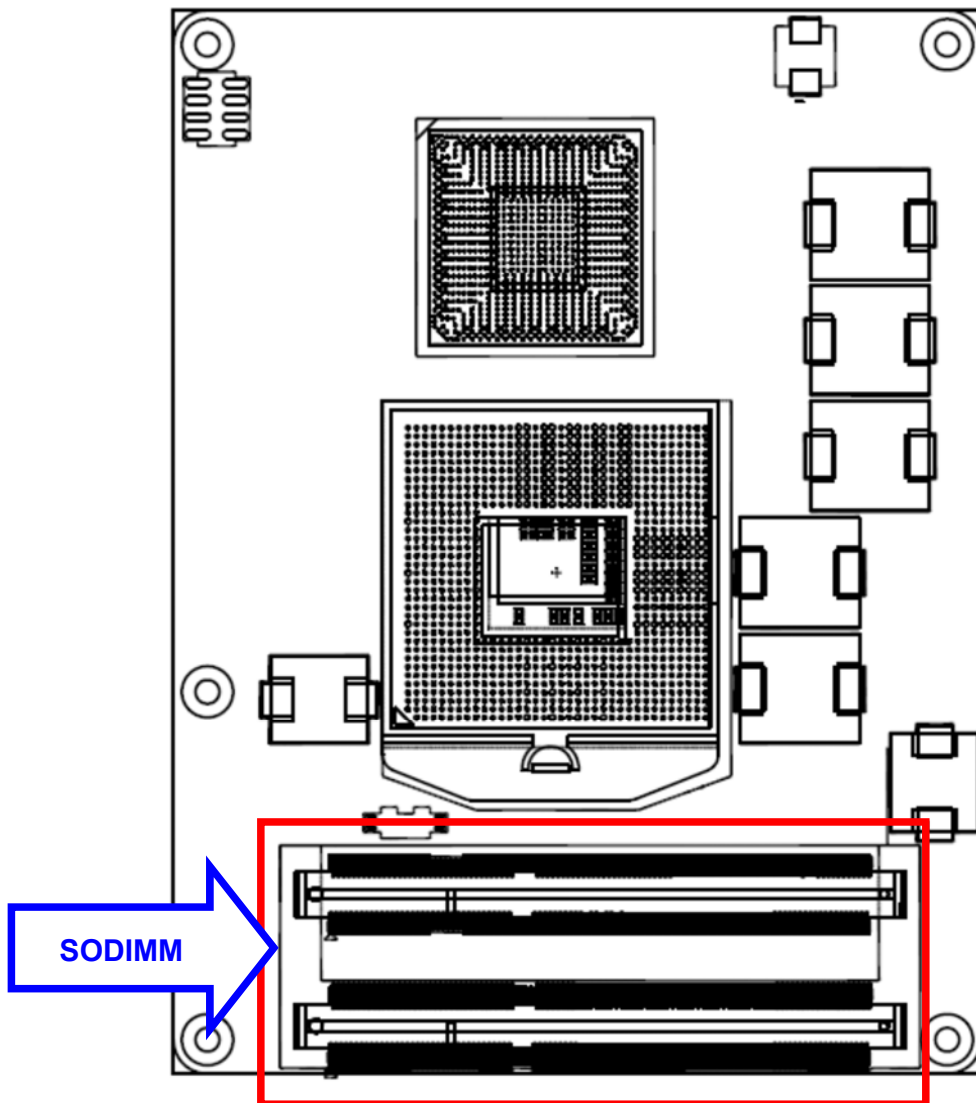

Make sure to unplug the power supply before adding or removing DIMMs or other system components. Failure to do so may cause severe damage to board and components.

- Locate the SODIMM socket on the board.
- Carefully hold two edges of the SODIMM module. avoid touching its connectors.
- Align the notch key on the module with the rib on the slot.
- Firmly press the modules into the socket which automatically snaps into the mounting notch. Do not force the SODIMM module in with extra force as the SODIMM module only fits in one direction.

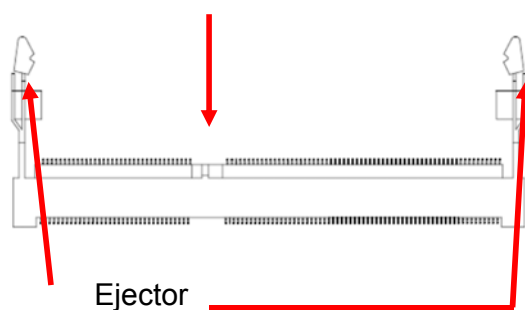
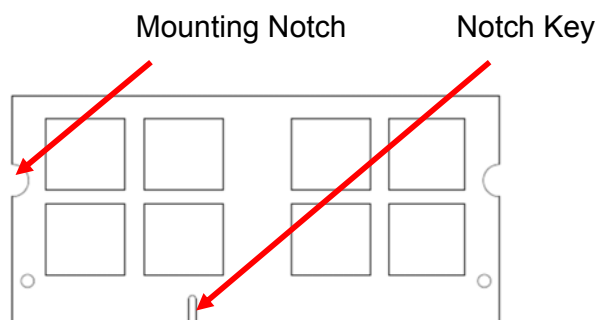

204-pin DDR3 SODIMM

- To remove SODIMM modules, simultaneously push the two ejector tabs outward, then pull out the SODIMM module.



Note:

- (1) Please do not change any DDR3 SDRAM parameter in BIOS setup to increase your system's performance without acquiring technical information in advance.
- (2) Static electricity can damage the electronic components of the computer or optional boards. Before proceeding, ensure that you are discharged of static electricity by briefly touching a grounded metal object.

2.3 Connector List

You can configure your board to match the needs of your application by setting jumpers. A jumper is the simplest kind of electric switch.

It consists of two metal pins and a small metal clip (often protected by a plastic cover) that slides over the pins to connect them. To “close” a jumper you connect the pins with the clip. To “open” a jumper you remove the clip. Sometimes a jumper will have three pins, labeled 1, 2, and 3. In this case, you would connect either two pins.

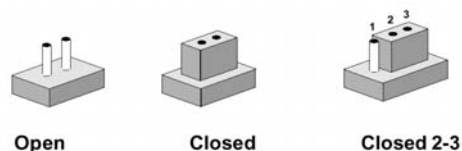

The jumper settings are schematically depicted in this manual as follows:



A pair of needle-nose pliers may be helpful when working with jumpers.

Connectors on the board are linked to external devices such as hard disk drives, a keyboard, or floppy drives. In addition, the board has a number of jumpers that allow you to configure your system to suit your application.

If you have any doubts about the best hardware configuration for your application, contact your local distributor or sales representative before you make any changes.

The following tables list the function of each of the board’s jumpers and connectors.

Connectors

Label	Function	Note
JSPI1	(Reserved for BIOS programming)	4 x 2 header, pitch 2.0mm
CN1A	COM Express connector 1	
CN1B	COM Express connector 2	
SODIMM1	204-pin DDR3 SDRAM DIMM socket	
SODIMM2	204-pin DDR3 SDRAM DIMM socket	
SW1	AT/ATX mode selector	

2.4 Setting Jumpers & Connectors

2.4.1 AT/ATX mode selector (SW1)

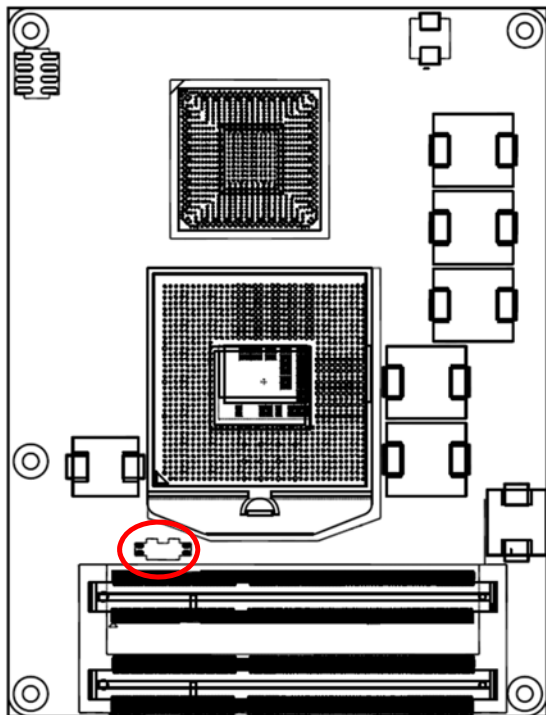

AT/ATX mode



AT mode



ATX mode*

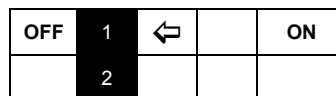

*Default

2.4.1.1 Signal Description –AT/ATX mode selection

AT/ATX mode	Description
<p>AT mode</p>	<p>This Mode supports AT power supply, no need to press Power button to enable power on/off</p>
<p>ATX mode</p>	<p>This Mode supports ATX power supply. Press the ATX power button to enable power on/off</p>

ESM-QM77

2.4.2 COM Express Connector 1 (CN1A)

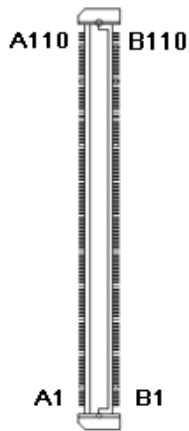
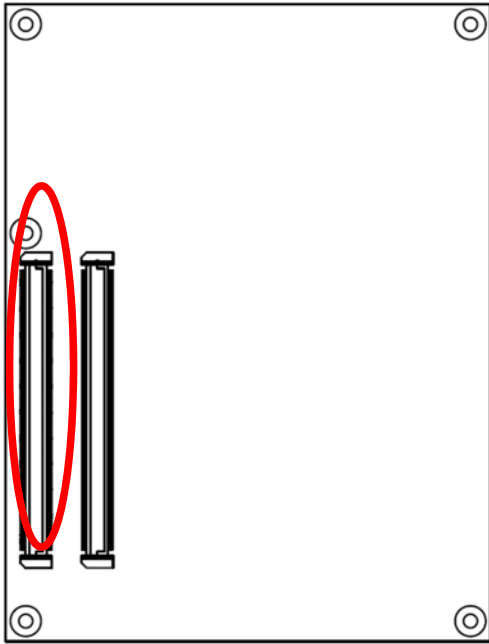

Signal	PIN	PIN	Signal
GND	A1	B1	GND
GBE0_MDI3-	A2	B2	GBE0_ACT#
GBE0_MDI3+	A3	B3	LPC_FRAME#
GBE0_LINK100#	A4	B4	LPC_AD0
GBE0_LINK1000#	A5	B5	LPC_AD1
GBE0_MDI2-	A6	B6	LPC_AD2
GBE0_MDI2+	A7	B7	LPC_AD3
GBE0_LINK#	A8	B8	LPC_DRQ0#
GBE0_MDI1-	A9	B9	LPC_DRQ1#
GBE0_MDI1+	A10	B10	LPC_CLK
GND	A11	B11	GND
GBE0_MDI0-	A12	B12	PWRBTN#
GBE0_MDI0+	A13	B13	SMB_CK
GBE0_CTREF	A14	B14	SMB_DAT
SUS_S3#	A15	B15	SMB_ALERT#
SATA0_TX+	A16	B16	SATA1_TX+
SATA0_TX-	A17	B17	SATA1_TX-
SUS_S4#	A18	B18	SUS_STAT#
SATA0_RX+	A19	B19	SATA1_RX+
SATA0_RX-	A20	B20	SATA1_RX-
GND	A21	B21	GND
SATA2_TX+	A22	B22	SATA3_TX+
SATA2_TX-	A23	B23	SATA3_TX-
SUS_S5#	A24	B24	PWR_OK
SATA2_RX+	A25	B25	SATA3_RX+
SATA2_RX-	A26	B26	SATA3_RX-
BATLOW#	A27	B27	WDT
(S)ATA_ACT#	A28	B28	AC/HDA_SDIN2
AC/HDA_SYNC	A29	B29	AC/HDA_SDIN1
AC/HDA_RST#	A30	B30	AC/HDA_SDIN0

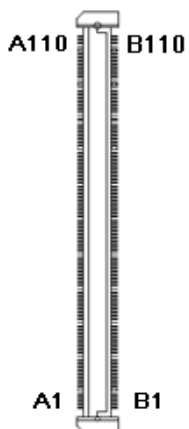
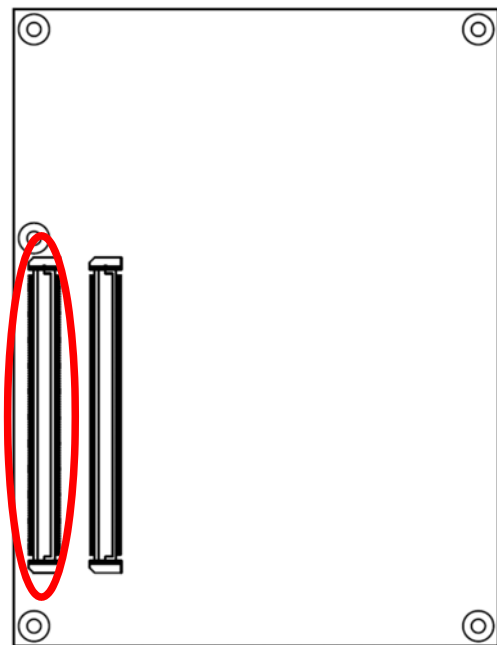

Signal	PIN	PIN	Signal
GND	A31	B31	GND
AC/HDA_BITCLK	A32	B32	SPKR
AC/HDA_SDOUT	A33	B33	NC
BIOS_DIS0#	A34	B34	NC
THRMTRIP#	A35	B35	THRM#
USB6-	A36	B36	USB7-
USB6+	A37	B37	USB7+
USB_6_7_OC#	A38	B38	USB_4_5_OC#
USB4-	A39	B39	USB5-
USB4+	A40	B40	USB5+
GND	A41	B41	GND
USB2-	A42	B42	USB3-
USB2+	A43	B43	USB3+
USB_2_3_OC#	A44	B44	USB_0_1_OC#
USB0-	A45	B45	USB1-
USB0+	A46	B46	USB1+
VCC_RTC	A47	B47	EXCD1_PERST#
EXCD0_PERST#	A48	B48	EXCD1_CPPE#
EXCD0_CPPE#	A49	B49	SYS_RESET#
LPC_SERIRQ	A50	B50	CB_RESET#
GND	A51	B51	GND
PCIE_TX5+	A52	B52	PCIE_RX5+
PCIE_TX5-	A53	B53	PCIE_RX5-
GPI0	A54	B54	GPO1
PCIE_TX4+	A55	B55	PCIE_RX4+
PCIE_TX4-	A56	B56	PCIE_RX4-
GND	A57	B57	GPO2
PCIE_TX3+	A58	B58	PCIE_RX3+
PCIE_TX3-	A59	B59	PCIE_RX3-
GND	A60	B60	GND

ESM-QM77

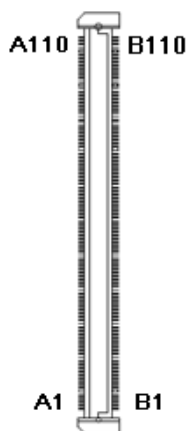
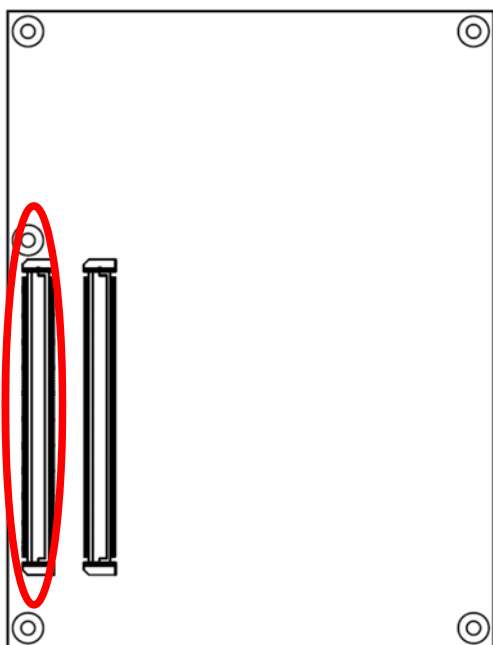

Signal	PIN	PIN	Signal
PCIE_TX2+	A61	B61	PCIE_RX2+
PCIE_TX2-	A62	B62	PCIE_RX2-
GPI1	A63	B63	GPO3
PCIE_TX1+	A64	B64	PCIE_RX1+
PCIE_TX1-	A65	B65	PCIE_RX1-
GND	A66	B66	WAKE0#
GPI2	A67	B67	WAKE1#
PCIE_TX0+	A68	B68	PCIE_RX0+
PCIE_TX0-	A69	B69	PCIE_RX0-
GND	A70	B70	GND
LVDS_A0+	A71	B71	LVDS_B0+
LVDS_A0-	A72	B72	LVDS_B0-
LVDS_A1+	A73	B73	LVDS_B1+
LVDS_A1-	A74	B74	LVDS_B1-
LVDS_A2+	A75	B75	LVDS_B2+
LVDS_A2-	A76	B76	LVDS_B2-
LVDS_VDD_EN	A77	B77	LVDS_B3+
LVDS_A3+	A78	B78	LVDS_B3-
LVDS_A3-	A79	B79	LVDS_BKLT_EN
GND	A80	B80	GND
LVDS_A_CK+	A81	B81	LVDS_B_CK+
LVDS_A_CK-	A82	B82	LVDS_B_CK-
LVDS_I2C_CK	A83	B83	LVDS_BKLT_CTRL
LVDS_I2C_DAT	A84	B84	VCC_5V_SBY
GPI3	A85	B85	VCC_5V_SBY
KB_RST#	A86	B86	VCC_5V_SBY
KB_A20GATE	A87	B87	VCC_5V_SBY
PCIE_CLK_REF+	A88	B88	BIOS_DIS1#
PCIE_CLK_REF-	A89	B89	VGA_RED
GND	A90	B90	GND

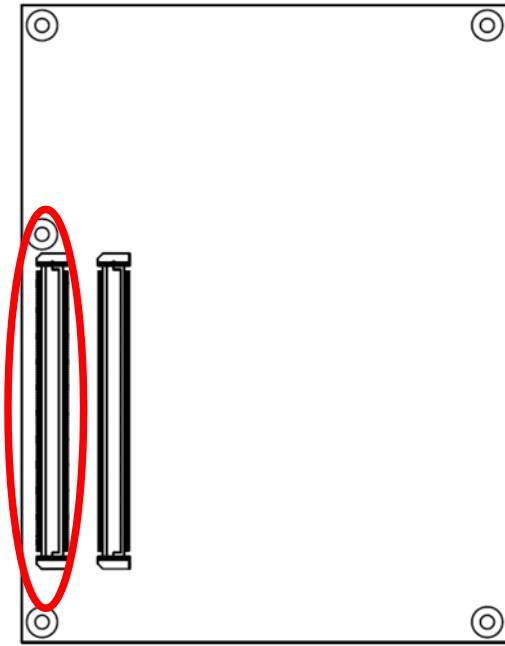

Signal	PIN	PIN	Signal
SPI_POWER	A91	B91	VGA_GRN
SPI_MISO	A92	B92	VGA_BLU
GPO0	A93	B93	VGA_HSYNC
SPI_CLK	A94	B94	VGA_VSYNC
SPI_MOSI	A95	B95	VGA_I2C_CK
PP_TPM	A96	B96	VGA_I2C_DAT
TYPE10#	A97	B97	SPI_CS#
NC	A98	B98	NC
NC	A99	B99	NC
GND	A100	B100	GND
NC	A101	B101	FAN_PWMOUT
NC	A102	B102	FAN_TACHIN
LID#	A103	B103	SLEEP#
VCC_12V	A104	B104	VCC_12V
VCC_12V	A105	B105	VCC_12V
VCC_12V	A106	B106	VCC_12V
VCC_12V	A107	B107	VCC_12V
VCC_12V	A108	B108	VCC_12V
VCC_12V	A109	B109	VCC_12V
GND	A110	B110	GND

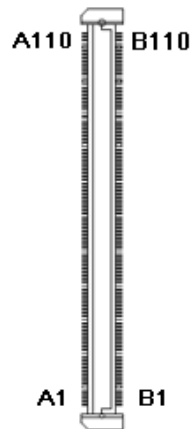

ESM-QM77

2.4.2.1 Signal Description – COM Express Connector 1 (CN1A)

2.4.2.1.1 Audio Signals

Signal	Signal Description
AC/HDA_SYNC	HD Audio Sync
AC/HDA_RST#	HD Audio Reset
AC/HDA_SDIN[0:2]	Audio CODEC Serial Data
AC/HDA_BITCLK	HD Audio Clock
AC/HDA_SDOUT	HD Audio Data

2.4.2.1.2 Gigabit Ethernet Signals

Signal	Signal Description																				
GBE0_MD[0:3] +/-	Gigabit Ethernet Controller 0: Media Dependent Interface Differential Pairs 0,1,2,3. The MDI can operate in 1000, 100 and 10 Mbit / sec modes. Some pairs are unused in some modes, per the following:																				
	<table border="1"><thead><tr><th></th><th>1000B-T</th><th>100B-T</th><th>10B-T</th></tr></thead><tbody><tr><td>MDI[0] +/-</td><td>B1_DA+</td><td>TX+/-</td><td>TX+/-</td></tr><tr><td>MDI[1] +/-</td><td>B1_DB+</td><td>RX+/-</td><td>RX+/-</td></tr><tr><td>MDI[2] +/-</td><td>B1_DC+</td><td>X</td><td>X</td></tr><tr><td>MDI[3] +/-</td><td>B1_DD+</td><td>X</td><td>X</td></tr></tbody></table>		1000B-T	100B-T	10B-T	MDI[0] +/-	B1_DA+	TX+/-	TX+/-	MDI[1] +/-	B1_DB+	RX+/-	RX+/-	MDI[2] +/-	B1_DC+	X	X	MDI[3] +/-	B1_DD+	X	X
		1000B-T	100B-T	10B-T																	
	MDI[0] +/-	B1_DA+	TX+/-	TX+/-																	
	MDI[1] +/-	B1_DB+	RX+/-	RX+/-																	
MDI[2] +/-	B1_DC+	X	X																		
MDI[3] +/-	B1_DD+	X	X																		
GBE0_ACT#	Gigabit Ethernet Controller 0 activity indicator, active low.																				
GBE0_Link#	Gigabit Ethernet Controller 0 link indicator, active low.																				
GBE0_Link100#	Gigabit Ethernet Controller 0 100 Mbit / sec link indicator, active low.																				
GBE0_Lin1000#	Gigabit Ethernet Controller 0 1000 Mbit / sec link indicator, active low.																				

2.4.2.1.3 GPIO Signals

Signal	Signal Description
GPI[0:4]	General purpose input pins.
GPO[0:4]	General purpose output pins.

2.4.2.1.4 LPC Signals

Signal	Signal Description
LPC_FRAME#	LPC frame indicates the start of an LPC cycle
LPC_AD[0:3]	LPC multiplexed address, command and data bus
LPC_DRQ[0:1]#	LPC serial DMA request
LPC_CLK	LPC clock output - 33MHz nominal
LPC_SERIRQ	LPC serial interrupt

2.4.2.1.5 Miscellaneous Signals

Signal	Signal Description							
SPKR	Output for audio enunciator - the "speaker" in PC-AT systems							
BIOS_DIS0# BIOS_DIS1#	Selection straps to determine the BIOS boot device							
	S_DIS1#	BIOS_DIS0#	Chipset SPI CS1# Destination	Chipset SPI CS0# Destination	Carrier SPI_CS#	SPI Descriptor	Bios Entry	
	1	1	Module	Module	High	Module	SPI0/SPI1	
	1	0	Module	Module	High	Module	Carrier FWH	
	0	1	Module	Carrier	SPI0	Carrier	SPI0/SPI1	
0	0	Carrier	Module	SPI1	Module	SPI0/SPI1		
KB_RST#	Input to module from external keyboard controller that can force a reset.							
KB_A20GATE	Input to module from external keyboard controller that can be used to control the CPU A20 gate line.							

2.4.2.1.6 PCI Express Signals

Signal	Signal Description
PCIE_TX[0:4] +/-	PCI Express Differential Transmit Pair 0-4
PCIE_RX[0:4] +/-	PCI Express Differential Receive Pair 0-4
PCIE0_CK_REF+/-	Reference clock output for PCI Express lanes 0-7 and for PCI Express Graphics lanes 0-15

ESM-QM77

2.4.2.1.7 Power Signals

Signal	Signal Description
VCC_5V_SBY	Standby power input: +5.0V nominal. See Electrical Specifications for allowable input range. If VCC5_SBY is used, all available VCC_5V_SBY pins on the connector(s) must be used. Only used for standby and suspend functions. May be left unconnected if these functions are not used in the system design.
VCC_RTC	Real-time clock circuit-power input. Nominally +3.0V.

2.4.2.1.8 Power & System Management Signals

Signal	Signal Description
SUS_S3#	Indicates system is in Suspend to RAM state. Active low output.
SUS_S4#	Indicates system is in Suspend to Disk state. Active low output.
SUS_S5#	Indicates system is in Soft Off state.
BATLOW#	Indicates that external battery is low
PWRBTN#	Power button to bring system out of S5 (soft off), active on rising edge.
SMB_CK	System Management Bus bidirectional clock line.
SMB_DTA	System Management Bus bidirectional data line.
SMB_ALERT#	System Management Bus Alert - input can be used to generate an SMI# (System Management Interrupt) or to wake the system.
SUS_STAT#	Indicates imminent suspend operation.
PWR_OK	Power OK from main power supply
THRMTRIP#	Active low output indicating that the CPU has entered thermal shutdown.
THRM#	Input from off-module temp sensor indicating and over-temp situation.
SYS_RESET#	Reset button input. Active low input.
WAKE0#	PCI Express wake up signal.
WAKE1#	General purpose wake up signal.

2.4.2.1.9 SATA Signals

Signal	Signal Description
SATA[0:3]_TX +/-	Serial ATA Channel 0-3 transmit differential pair.
SATA[0:3]_RX +/-	Serial ATA Channel 0-3receive differential pair.
ATA_ACT#	Serial ATA activity indicator, active low.

2.4.2.1.10 VGA Signals

Signal	Signal Description
VGA_RED	Red for monitor. Analog DAC output.
VGA_GRN	Green for monitor. Analog DAC output.
VGA_BLU	Blue for monitor. Analog DAC output.
VGA_HSYNC	Horizontal sync output to VGA monitor
VGA_VSYNC	Vertical sync output to VGA monitor
VGA_I ² C_CK	DDC clock line (I2C port dedicated to identify VGA monitor capabilities)
VGA_I ² C_DAT	DDC data line.

2.4.2.1.11 USB Signals

Signal	Signal Description
USB[0:7] +/-	USB differential pairs, channels 0 through 7
USB_0_1_OC#	USB over-current sense, USB channels 0 and 1
USB_2_3_OC#	USB over-current sense, USB channels 2 and 3
USB_4_5_OC#	USB over-current sense, USB channels 4 and 5
USB_6_7_OC#	USB over-current sense, USB channels 6 and 7

2.4.2.1.12 LVDS Flat Panel Signals

Signal	Signal Description
LVDS_A[0:3] + LVDS_A[0:3] -	LVDS Channel A differential pairs
LVDS_A_CK + LVDS_A_CK -	LVDS Channel A differential clock
LVDS_B[0:3] + LVDS_B[0:3] -	LVDS Channel B differential pairs
LVDS_B_CK + LVDS_B_CK -	LVDS Channel B differential clock
LVDS_VDD_EN	LVDS panel power enable
LVDS_BKLT_EN	LVDS panel backlight enable
LVDS_BKLT_CTRL	LVDS panel backlight brightness control
LVDS_I ² C_CK	I ² C clock output for LVDS display use
LVDS_I ² C_DAT	I ² C data line for LVDS display use

ESM-QM77

2.4.3 COM Express Connector 2 (CN1B)

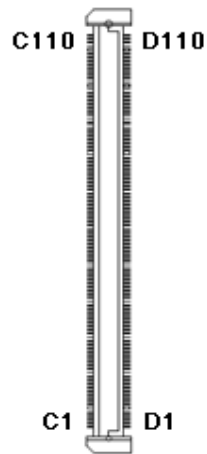
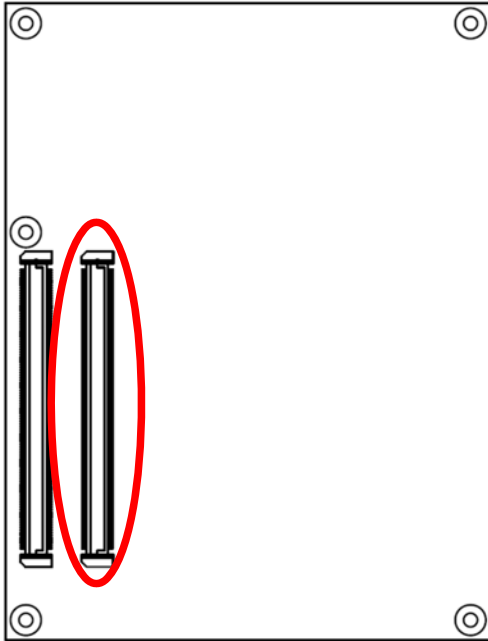

Signal	PIN	PIN	Signal
GND	C1	D1	GND
GND	C2	D2	GND
USB_SSRX0-	C3	D3	USB_SSTX0-
USB_SSRX0+	C4	D4	USB_SSTX0+
GND	C5	D5	GND
USB_SSRX1-	C6	D6	USB_SSTX1-
USB_SSRX1+	C7	D7	USB_SSTX1+
GND	C8	D8	GND
USB_SSRX2-	C9	D9	USB_SSTX2-
USB_SSRX2+	C10	D10	USB_SSTX2+
GND	C11	D11	GND
USB_SSRX3-	C12	D12	USB_SSTX3-
USB_SSRX3+	C13	D13	USB_SSTX3+
GND	C14	D14	GND
DDI1_PAIR6+	C15	D15	DDI1_CTRLCLK_AUX+
DDI1_PAIR6-	C16	D16	DDI1_CTRLDATA_AUX-
NC	C17	D17	NC
NC	C18	D18	NC
PCIE_RX6+	C19	D19	PCIE_TX6+
PCIE_RX6-	C20	D20	PCIE_TX6-
GND	C21	D21	GND
NC	C22	D22	NC
NC	C23	D23	NC
DDI1_HPD	C24	D24	NC
DDI1_PAIR4+	C25	D25	NC
DDI1_PAIR4-	C26	D26	DDI1_PAIR0+
NC	C27	D27	DDI1_PAIR0-
NC	C28	D28	NC
DDI1_PAIR5+	C29	D29	DDI1_PAIR1+
DDI1_PAIR5-	C30	D30	DDI1_PAIR1-

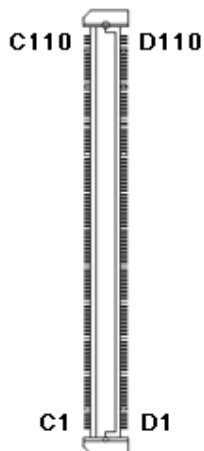
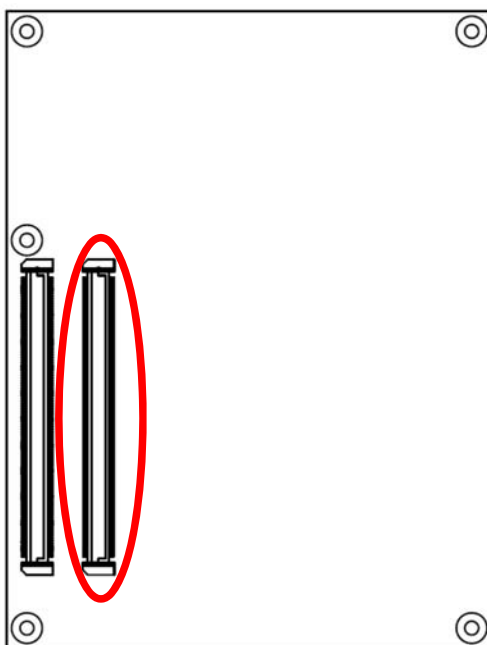

Signal	PIN	PIN	Signal
GND	C31	D31	GND
DDI2_CTRLCLK_AUX+	C32	D32	DDI1_PAIR2+
DDI2_CTRLDATA_AUX-	C33	D33	DDI1_PAIR2-
DDI2_DDC_AUX_SEL	C34	D34	DDI1_DDC_AUX_SEL
NC	C35	D35	NC
DDI3_CTRLCLK_AUX+	C36	D36	DDI1_PAIR3+
DDI3_CTRLDATA_AUX-	C37	D37	DDI1_PAIR3-
DDI3_DDC_AUX_SEL	C38	D38	NC
DDI3_PAIR0+	C39	D39	DDI2_PAIR0+
DDI3_PAIR0-	C40	D40	DDI2_PAIR0-
GND	C41	D41	GND
DDI3_PAIR1+	C42	D42	DDI2_PAIR1+
DDI3_PAIR1-	C43	D43	DDI2_PAIR1-
DDI3_HPD	C44	D44	DDI2_HPD
NC	C45	D45	NC
DDI3_PAIR2+	C46	D46	DDI2_PAIR2+
DDI3_PAIR2-	C47	D47	DDI2_PAIR2-
NC	C48	D48	NC
DDI3_PAIR3+	C49	D49	DDI2_PAIR3+
DDI3_PAIR3-	C50	D50	DDI2_PAIR3-
GND	C51	D51	GND
PEG_RX0+	C52	D52	PEG_TX0+
PEG_RX0-	C53	D53	PEG_TX0-
TYPE0#	C54	D54	PEG_LANE_RV#
PEG_RX1+	C55	D55	PEG_TX1+
PEG_RX1-	C56	D56	PEG_TX1-
TYPE1#	C57	D57	TYPE2#
PEG_RX2+	C58	D58	PEG_TX2+
PEG_RX2-	C59	D59	PEG_TX2-
GND	C60	D60	GND

ESM-QM77

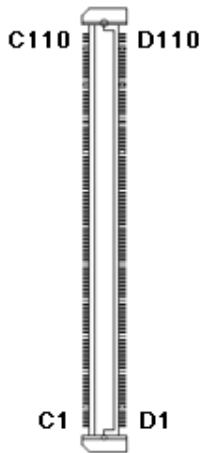
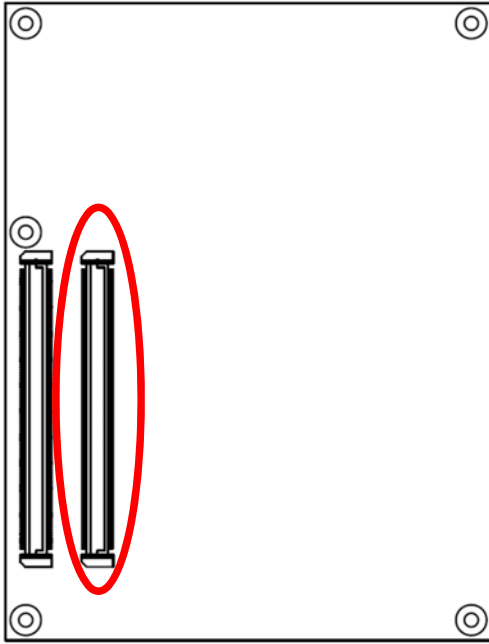

Signal	PIN	PIN	Signal
PEG_RX3+	C61	D61	PEG_TX3+
PEG_RX3-	C62	D62	PEG_TX3-
NC	C63	D63	NC
NC	C64	D64	NC-
PEG_RX4+	C65	D65	PEG_TX4+
PEG_RX4-	C66	D66	PEG_TX4-
NC	C67	D67	GND
PEG_RX5+	C68	D68	PEG_TX5+
PEG_RX5-	C69	D69	PEG_TX5-
GND	C70	D70	GND
PEG_RX6+	C71	D71	PEG_TX6+
PEG_RX6-	C72	D72	PEG_TX6-
GND	C73	D73	GND
PEG_RX7+	C74	D74	PEG_TX7+
PEG_RX7-	C75	D75	PEG_TX7-
GND	C76	D76	GND
NC	C77	D77	NC
PEG_RX8+	C78	D78	PEG_TX8+
PEG_RX8-	C79	D79	PEG_TX8-
GND	C80	D80	GND
PEG_RX9+	C81	D81	PEG_TX9+
PEG_RX9-	C82	D82	PEG_TX9-
NC	C83	D83	NC
GND	C84	D84	GND
PEG_RX10+	C85	D85	PEG_TX10+
PEG_RX10-	C86	D86	PEG_TX10-
GND	C87	D87	GND
PEG_RX11+	C88	D88	PEG_TX11+
PEG_RX11-	C89	D89	PEG_TX11-
GND	C90	D90	GND

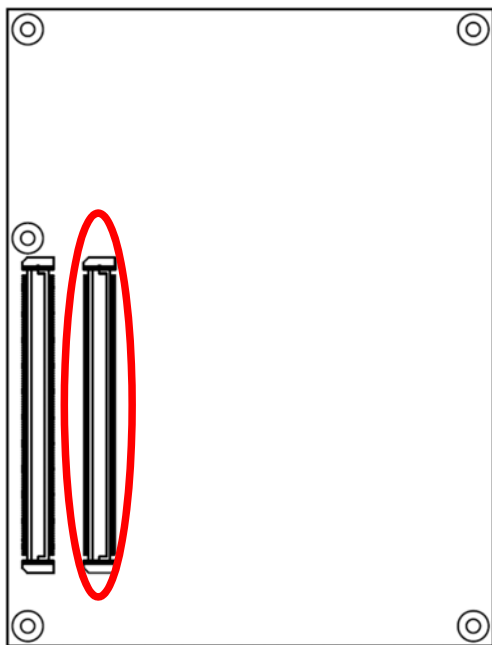

Signal	PIN	PIN	Signal
PEG_RX12+	C91	D91	PEG_TX12+
PEG_RX12-	C92	D92	PEG_TX12-
GND	C93	D93	GND
PEG_RX13+	C94	D94	PEG_TX13+
PEG_RX13-	C95	D95	PEG_TX13-
GND	C96	D96	GND
NC	C97	D97	NC
PEG_RX14+	C98	D98	PEG_TX14+
PEG_RX14-	C99	D99	PEG_TX14-
GND	C100	D100	GND
PEG_RX15+	C101	D101	PEG_TX15+
PEG_RX15-	C102	D102	PEG_TX15-
GND	C103	D103	GND
VCC_12V	C104	D104	VCC_12V
VCC_12V	C105	D105	VCC_12V
VCC_12V	C106	D106	VCC_12V
VCC_12V	C107	D107	VCC_12V
VCC_12V	C108	D108	VCC_12V
VCC_12V	C109	D109	VCC_12V
GND	C110	D110	GND

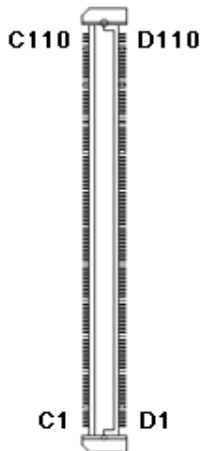

ESM-QM77

2.4.3.1 Signal Description – COM Express Connector 2 (CN1B)

2.4.3.1.1 USB Signals

Signal	Signal Description
USB_SSTX[0:3]+ USB_SSTX[0:3]-	Additional transmit signal differential pairs for the SuperSpeed USB data path.
USB_SSRX[0:3]+ USB_SSRX[0:3]-	Additional receive signal differential pairs for the SuperSpeed USB data path.

2.4.3.1.2 PEG Signals

Signal	Signal Description
PEG_TX[0:15]+ PEG_TX[0:15]-	PCI Express Graphics transmit differential paris.
PEG_RX[0:15]+ PEG_RX[0:15]-	PCI Express Graphics receive differential paris.
PEG_LANE_RV#	PCI Express Graphics lane reversal input strap. Pull low on the Carrier board to reverse lane order.

2.4.3.1.3 DDI Signals

Signal	Signal Description
DDI[1:3]_PAIR[0:3]+ DDI[1:3]_PAIR [0:3]-	Digital Display Interface 1 to 3 Pair[0:3] differential pairs
DDI[1:3]_DDC_AUX_SEL	Selects the function of DDI[1:3]_CTRLCLK_AUX+ and DDI[1:3]_CTRLDATA_AUX-. If this input is floating the AUX pair is used for the DP AUX+/- signals. If pulled-high the AUX pair contains the CTRLCLK and CTRLDATA signals.
DDI[1:3]_CTRLCLK_AUX+	DP AUX+function if DDI[1:3]_DDC_AUX_SEL is no connect HDMI/DVI 12C CTRLCLK if DDI[1:3]_DDC_AUX_SEL is pulled high
DDI[1:3]_CTRLDATA_AUX-	DP AUX-function if DDI[1:3]_DDC_AUX_SEL is no connect HDMI/DVI 12C CTRLDATA if DDI[1:3]_DDC_AUX_SEL is pulled high
DDI[1:3]_HPD	Digital Display Interface Hot-Plug Detect

2.4.3.1.3.1 DDI1~3 Signals

Signal	Signal Description
DDI1	DDPB
DDI2	DDPC
DDI3	DDPD

2.5 Intel HD Graphics – 3 Active Displays Support

QM77 supports 3 Display Digital Ports B, C, D. (DDPB, DDPC and DDPD):

DDPB: Capable of HDMI/DVI/DisplayPort/SDVO

DDPC: Capable of HDMI/DVI/DisplayPort

DDPD: Capable of HDMI/DVI/DisplayPort

Due to the hardware design of ESM-QM77 and EEV-EX14, the onboard HDMI interface support by DDPC and Display Port is support by DDPD. DDPB is connected to Digital Display Interface(DDI), and it could support HDMI/DVI/DP/SDVO via add on adapter card. The table below lists supported 3 display combinations on EEV-EX14 carrier board.

Configuration	Display 1	Display 2	Display 3
1	CRT	DP B	DP D
2	LFP	DP B	DP D
3	DP B	HDMI C	DP D

Depends on carrier board design, table below shows possible supported display combinations

Configuration	Display 1	Display 2	Display 3
1	CRT	DP B	DP C
2	CRT	DP C	DP D
3	CRT	DP B	DP D
4	LFP	DP C	DP D
5	LFP	DP B	DP D
6	LFP	DP B	DP C
7	DP B	DPC	DP D
8	DP B	DP C	HDMI D
9	DP B	DP D	HDMI C
10	DP C	DP D	HDMI B

Triple Clone: all the three display show the same contents.

Triple extended: All the three display have independent content.

Note: This feature is not applicable for XP OS.

3. BIOS Setup

3.1 Introduction

The BIOS setup program allows users to modify the basic system configuration. In this following chapter will describe how to access the BIOS setup program and the configuration options that may be changed.

3.2 Starting Setup

The AMI BIOS™ is immediately activated when you first power on the computer. The BIOS reads the system information contained in the CMOS and begins the process of checking out the system and configuring it. When it finishes, the BIOS will seek an operating system on one of the disks and then launch and turn control over to the operating system.

While the BIOS is in control, the Setup program can be activated in one of two ways:

By pressing immediately after switching the system on, or

By pressing the key when the following message appears briefly at the bottom of the screen during the POST (Power On Self Test).

Press DEL to enter SETUP

If the message disappears before you respond and you still wish to enter Setup, restart the system to try again by turning it OFF then ON or pressing the "RESET" button on the system case. You may also restart by simultaneously pressing <Ctrl>, <Alt>, and <Delete> keys. Remove all storage can also enter the BIOS Setup Utility.

3.3 Using Setup

In general, you use the arrow keys to highlight items, press <Enter> to select, use the PageUp and PageDown keys to change entries, press <F1> for help and press <Esc> to quit. The following table provides more detail about how to navigate in the Setup program using the keyboard.

Button	Description
↑	Move to previous item
↓	Move to next item
←	Move to the item in the left hand
→	Move to the item in the right hand
Esc key	Main Menu -- Quit and not save changes into CMOS Status Page Setup Menu and Option Page Setup Menu -- Exit current page and return to Main Menu
PgUp key	Increase the numeric value or make changes
PgDn key	Decrease the numeric value or make changes
+ key	Increase the numeric value or make changes
- key	Decrease the numeric value or make changes
F1 key	General help, only for Status Page Setup Menu and Option Page Setup Menu
F2 key	Previous Values.
F3 key	Optimized defaults
F4 key	Save & Exit Setup

- **Navigating Through The Menu Bar**

Use the left and right arrow keys to choose the menu you want to be in.



Note: Some of the navigation keys differ from one screen to another.

- **To Display a Sub Menu**

Use the arrow keys to move the cursor to the sub menu you want. Then press <Enter>.

A “>” pointer marks all sub menus.

3.4 Getting Help

Press F1 to pop up a small help window that describes the appropriate keys to use and the possible selections for the highlighted item. To exit the Help Windows press <Esc> or <Enter> key.

3.5 In Case of Problems

If, after making and saving system changes with Setup, you discover that your computer no longer is able to boot, the AMI BIOS supports an override to the CMOS settings which resets your system to its defaults.

The best advice is to only alter settings which you thoroughly understand. To this end, we strongly recommend that you avoid making any changes to the chipset defaults. These defaults have been carefully chosen by both Award and your systems manufacturer to provide the absolute maximum performance and reliability. Even a seemingly small change to the chipset setup has the potential for causing you to use the override.

ESM-QM77

3.6 BIOS setup

Once you enter the AMI BIOS CMOS Setup Utility, the Main Menu will appear on the screen. The Main Menu allows you to select from several setup functions and exit choices. Use the arrow keys to select among the items and press <Enter> to accept and enter the sub-menu.

3.6.1 Main Menu

This section allows you to record some basic hardware configurations in your computer and set the system clock.

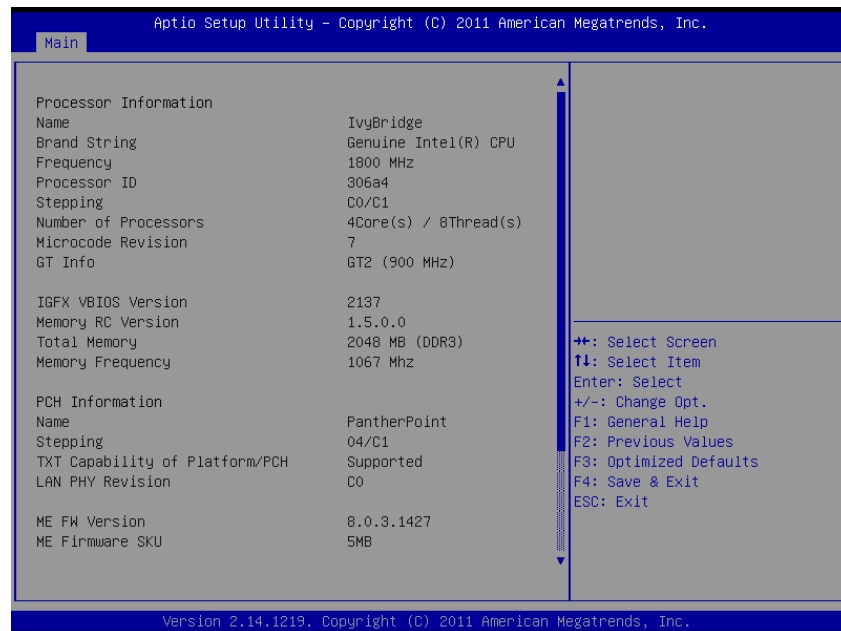
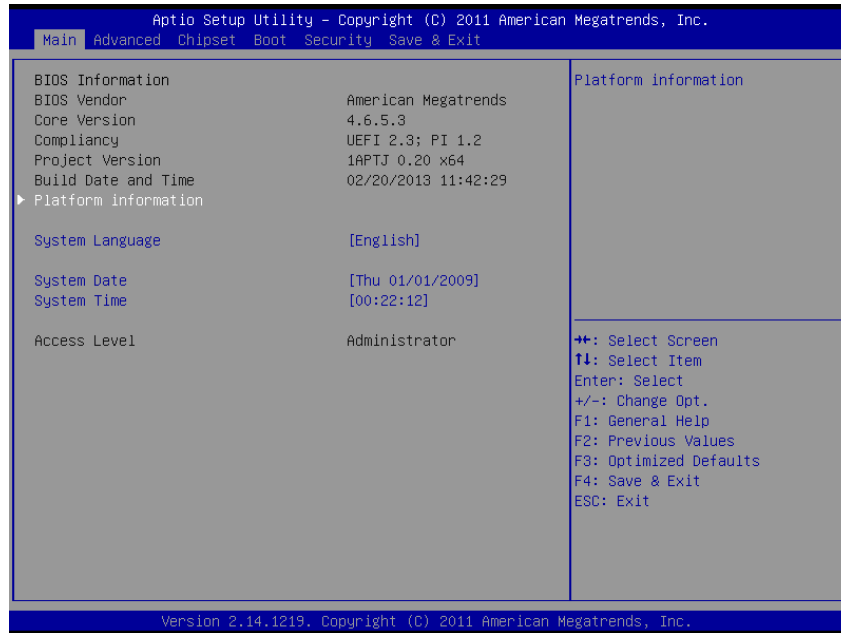

3.6.1.1 System Language

This option allows choosing the system default language.

3.6.1.2 System Date

Use the system date option to set the system date. Manually enter the day, month and year.

3.6.1.3 System Time

Use the system time option to set the system time. Manually enter the hours, minutes and seconds.



Note: The BIOS setup screens shown in this chapter are for reference purposes only, and may not exactly match what you see on your screen.

3.6.2 Advanced Menu

This section allows you to configure your CPU and other system devices for basic operation through the following sub-menus.

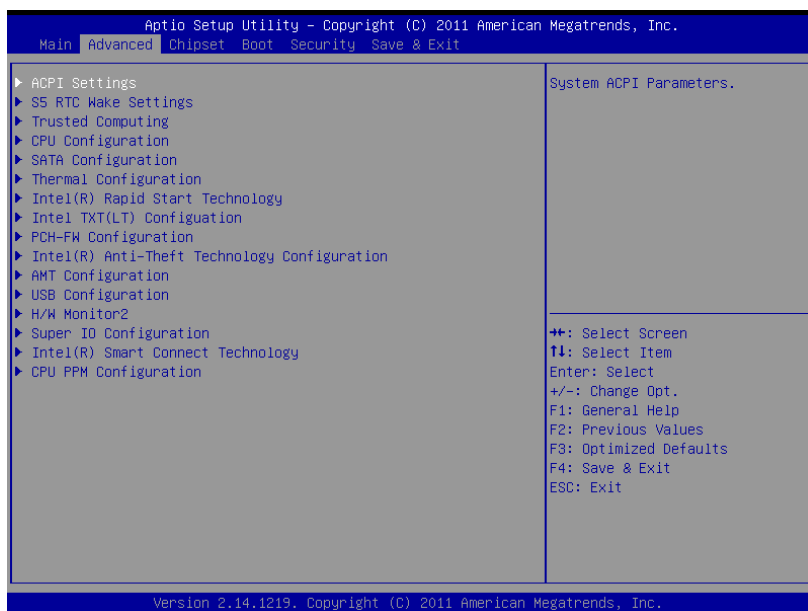

ESM-QM77

3.6.2.1 ACPI Settings

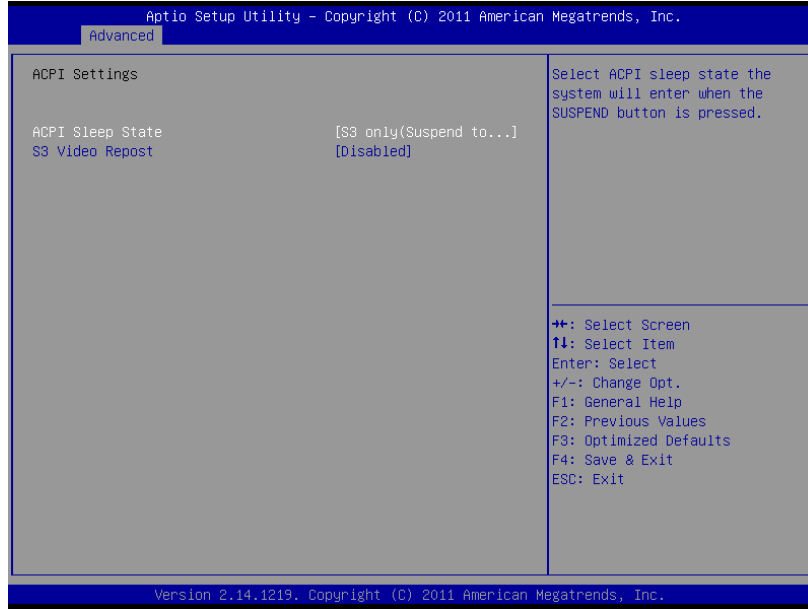

Item	Options	Description
ACPI Sleep State	Suspend Disabled S1 only(CPU Stop Clock) S3 only(Suspend to RAM) [Default]	Select ACPI sleep state the system will enter when the SUSPEND button is pressed.
S3 Video Repost	Disabled [Default] Enabled	Enable or Disable S3 Video Repost.

3.6.2.2 S5 RTC Wake Settings

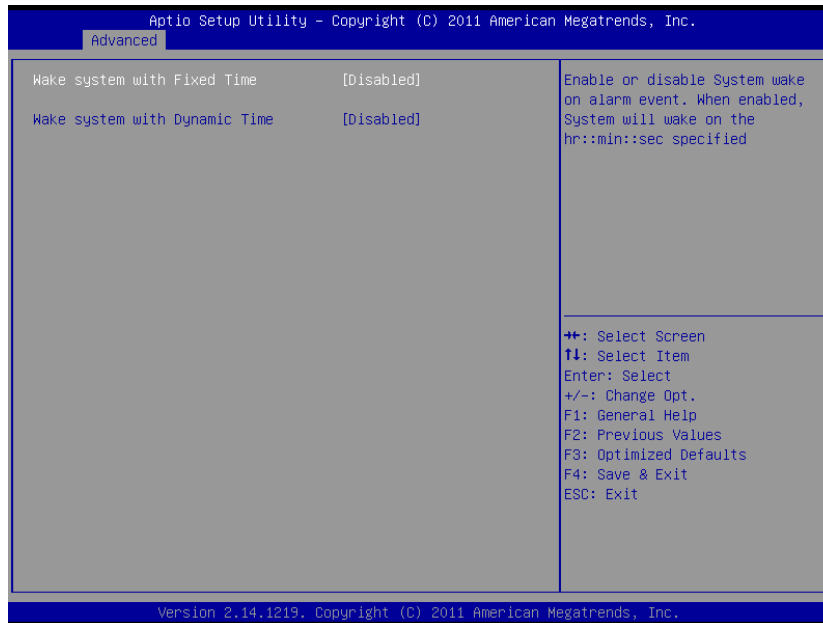

Item	Options	Description
Wake system with Fixed Time	Disabled[Default] Enabled	Enable or disable System wake on alarm event. When enabled, System will wake on the hr::min::sec specified.
Wake system with Dynamic Time	Disabled[Default] Enabled	Enable or disable System wake on alarm event. When enabled, System will wake on the current time + Increase minute(s).

3.6.2.3 Trusted Computing



Item	Options	Description
Security Device Support	Disable[Default] Enable	Enables or Disables BIOS support for security device. O.S. will not show Security Device. TCG EFI protocol and INT1A interface will not be available.

ESM-QM77

3.6.2.4 CPU Configuration

Use the CPU configuration menu to view detailed CPU specification and configure the CPU.

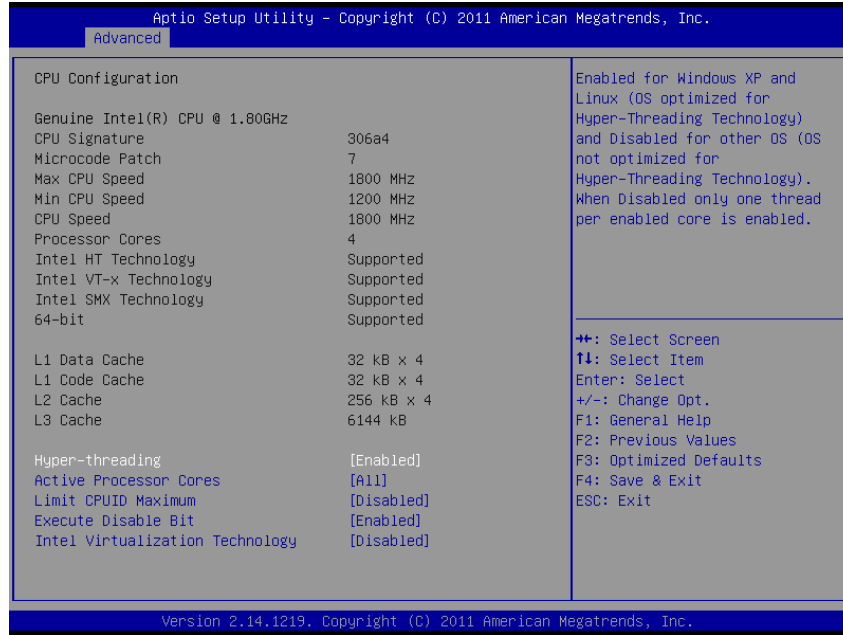

Item	Options	Description
Hyper-threading	Disabled Enabled[Default]	Enabled for Windows XP and Linux (OS optimized for Hyper-Threading Technology) and Disabled for other OS (OS not optimized for Hyper-Threading Technology). When Disabled only one thread per enabled core is enabled.
Active Processor Cores	All[Default] 1/2/3	Number of cores to enable in each processor package
Limit CPUID Maximum	Disabled[Default] Enabled	Disabled for Windows XP
Execute Disable Bit	Disabled Enabled[Default]	XD can prevent certain classes of malicious buffer overflow attacks when combined with a supporting OS (Windows Server 2003 SP1, Windows XP SP2, SuSE Linux 9.2, RedHat Enterprise 3 Update 3.)
Intel Virtualization Technology	Disabled[Default] Enabled	When enabled, a VMM can utilize the additional hardware capabilities provided by Vanderpool Technology.

3.6.2.5 SATA Configuration

It allows you to select the operation mode for SATA controller.

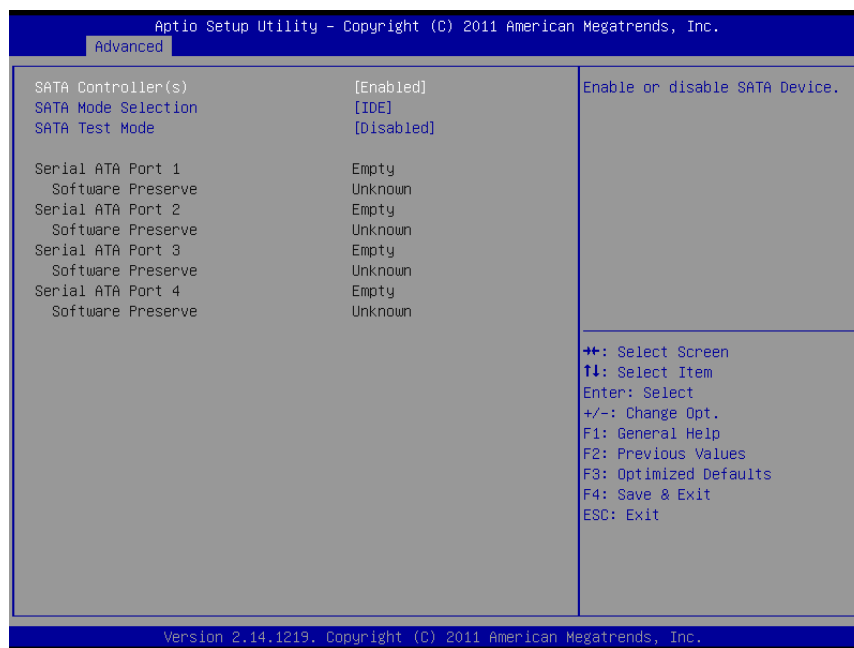

Item	Options	Description
SATA Controller(s)	Enabled[Default] Disabled	Enable or disable SATA Device.
SATA Mode Selection	IDE[Default] AHCI RAID	Determines how SATA controller(s) operate.
SATA Test Mode	Enabled Disabled[Default]	Enable or disable Test Mode.

ESM-QM77

3.6.2.6 Thermal Configuration



Item	Description
Platform Thermal Configuration	Platform Thermal Configuration options.

3.6.2.6.1 Platform Thermal Configuration



Item	Option	Description
Automatic Thermal Reporting	Disabled Enabled[Default]	Configure _CRT, _PSV and _AC0 automatically based on

		values recommended in BWG's Thermal Reporting for Thermal Management settings. Set to Disabled for manual configuration.
Active Trip Point 0 Fan Speed	0-100[Default]	Active Trip Point 0 Fan Speed in percentage. Value must be between 0 (Fan off) – 100 (Max fan speed). This is the speed at which fan will run when Active Trip Point 0 is crossed.
Active Trip Point 1	Disabled 15C 23C 31C 39C 47C 55C[Default] 63C 71C 79C 87C 95C 103C 111C 119C	This value controls the temperature of the ACPI Active Trip Point 1 – the point in which the OS will turn the processor fan on Active Trip Point 1 Fan Speed.
Active Trip Point 1 Fan Speed	0-100 75[Default]	Active Trip Point 1 Fan Speed in percentage. Value must be between 0 (Fan off) – 100 (Max fan speed). This value must be less than Active Trip Point 0 Fan speed. This is the speed at which.
Passive TC1 Value	1-16 1[Default]	This value sets the TC1 value for the ACPI Passive Cooling Formula. Range 1-16.
Passive TC2 Value	1-16 5[Default]	This value sets the TC2 value for the ACPI Passive Cooling Formula. Range 1-16.
Passive TSP Value	2-32 10[Default]	This item sets the TSP value for the ACPI Passive Cooling Formula. It represents in tenths of a second how often the OS will read the temperature when passive cooling is enabled. Range 2-32.
PCH Thermal Device	Disabled[Default] Enabled	Enable or disable PCH Thermal Device (D31:F6).
PCH Temp Read	Disabled	PCH Temperature Read

ESM-QM77

	Enabled[Default]	Enable.
CPU Energy Read	Disabled Enabled[Default]	CPU Energy Read Enable.
CPU Temp Read	Disabled Enabled[Default]	CPU Temperature Read Enable.
Alert Enable Lock	Disabled Enabled[Default]	Lock all Alert Enable settings.
PCH Alert	Disabled[Default] Enabled	PCH Alert pin enable.
DIMM Alert	Disabled[Default] Enabled	DIMM Alert pin enable.

3.6.2.7 Intel® Rapid Start Technology



3.6.2.8 Intel® TXT(LT) Configuration

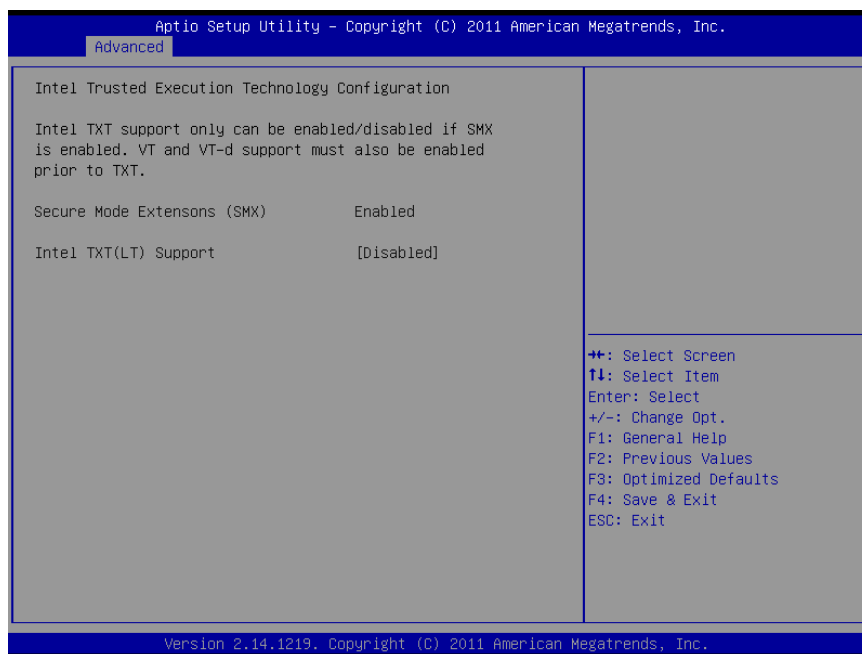

3.6.2.9 PCH-FW Configuration

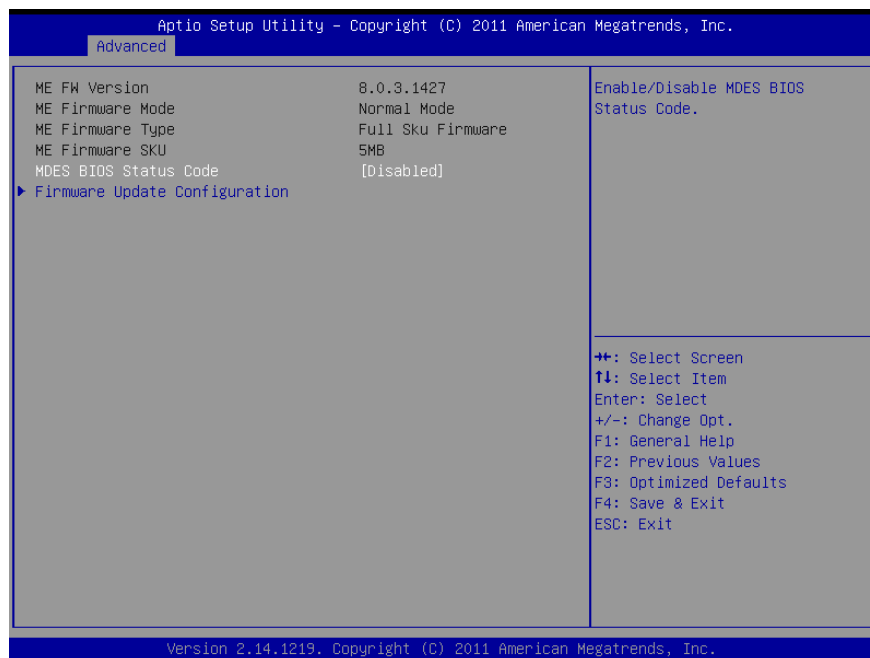

Item	Options	Description
MDES BIOS Status Code	Disabled[Default] Enabled	Enable/Disable MDES BIOS Status Code.
Firmware Update Configuration	Configure Management Engine Technology Parameters.	

ESM-QM77

3.6.2.9.1 Firmware Update Configuration

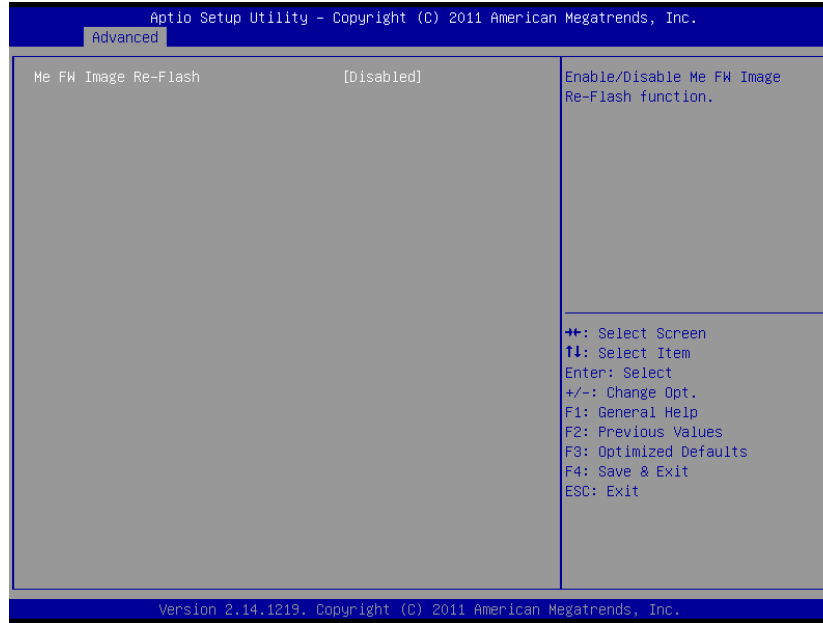

Item	Options	Description
Me FW Image Re-Flash	Disabled[Default] Enabled	Enable/Disable Me FW Image Re-Flash function.

3.6.2.10 Intel® Anti- Theft Technology Configuration



Item	Options	Description
Intel® Anti- Theft Technology	Disabled[Default] Enabled	Enable/Disable Intel® AT in BIOS for testing only.
Intel® Anti- Theft Technology Rec	1-64 3[Default]	Set the number of times Recovery attempted will be allowed.

3.6.2.11 AMT Configuration

Intel AMT allows hardware-based remote management, security, power-management, and remote-configuration features.

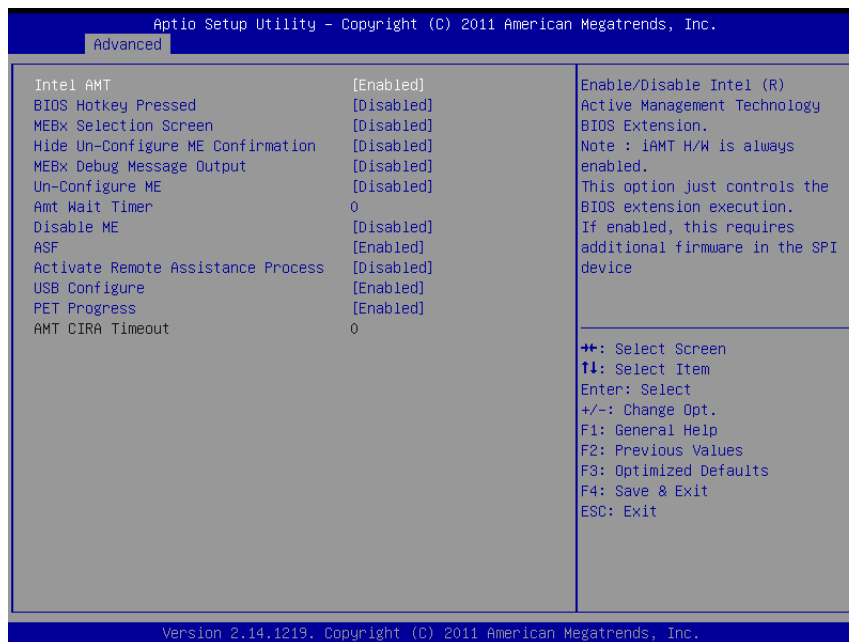

Item	Options	Description
Intel AMT	Enabled[Default] Disabled	Enable/Disable Intel © Active Management Technology BIOS Extension. Note: iAMT H/W is always enabled. This option just controls the BIOS extension execution. If enabled, this requires additional firmware in the SPI device
BIOS Hotkey Pressed	Enabled Disabled[Default]	OEMFLag Bit 1: Enable/Disable BIOS hotkey press.
MEBx Selection Screen	Enabled Disabled[Default]	OEMFLag Bit 2: Enable/Disable MEBx selection screen
Hide Un-Configure ME Confirmation	Enabled Disabled[Default]	OEMFLag Bit 6: Hide Un-Configure ME without password Confirmation Prompt.
MEBx Debug Message Output	Enabled Disabled[Default]	OEMFLag Bit 14: Enable MEBx debug message output
Un-Configure ME	Enabled Disabled[Default]	OEMFLag Bit 15: Un-Configure ME without password
Amt Wait Timer	0	Set timer to wait before sending ASF_GET_BOOT_OPTIONS.
Disable ME	Enabled Disabled[Default]	Set ME to Soft Temporary Disabled.
ASF	Enabled[Default] Disabled	Enable/Disable Alert Specification Format.
Activate Remote Assistance Process	Enabled Disabled[Default]	Trigger CIRA boot.
USB Configure	Enabled[Default] Disabled	Enable/Disable USB Configure function.
PET Progress	Enabled[Default] Disabled	User can Enable/Disable PET Events progress to receive PET events or not..

ESM-QM77

3.6.2.12 USB Configuration

The USB Configuration menu helps read USB information and configures USB settings.

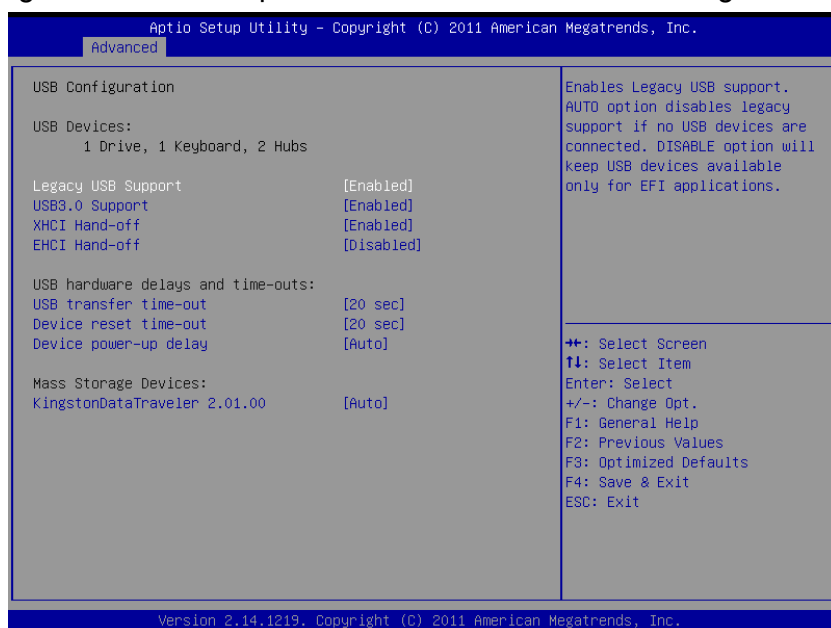

Item	Options	Description
Legacy USB Support	Enabled[Default] Disabled Auto	Enables Legacy USB support. AUTO option disables legacy support if no USB devices are connected. DISABLE option will keep USB devices available only for EFI applications.
USB3.0 Support	Enabled[Default] Disabled	Enable/Disable USB3.0 (XHCI) Controller support.
XHCI Hand-off	Enabled[Default] Disabled	This is a workaround for OSeS without XHCI hand-off support. The XHCI ownership change should be claimed by XHCI driver.
EHCI Hand-off	Enabled Disabled[Default]	This is a workaround for OSeS without EHCI hand-off support. The EHCI ownership change should be claimed by EHCI driver.
USB transfer time-out	1 sec 5 sec 10 sec 20 sec[Default]	The time-out value for Control, Bulk, and Interrupt transfers.
Device reset time-out	10 sec 20 sec[Default] 30 sec 40 sec	USB mass storage device Start Unit command time-out.
Device power-up delay	Auto[Default] Manual	Maximum time the device will take before it properly reports itself to the Host Controller. 'Auto' uses default value: for a Root port it is 100ms, for a Hub port the delay is taken from Hub descriptor.
Mass Storage Devices	Mass storage device emulation type. 'AUTO' enumerates devices according to their media format. Optical drives are emulated as 'CDROM', drives with no media will be emulated according to a drive type.	

3.6.2.13 H/W Monitor2

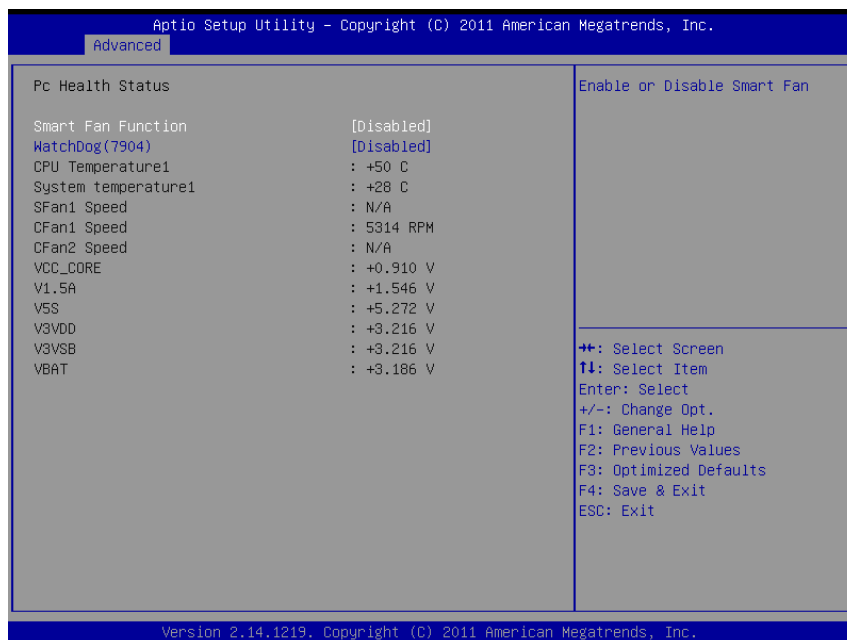

Item	Options	Description
Smart Fan Function	Enabled Disabled[Default]	Enable or Disable Smart Fan.
Watchdog(7904)	Disabled[Default]/1 Min/2 Min/3 Min /4 Min/5 Min/6 Min/7 Min/8Min/9 Min/10 Min	

3.6.2.14 Super IO Configuration

You can use this item to set up or change the Super IO configuration for serial ports.

Please refer to 3.6.2.14.1, 3.6.2.14.2 and 3.6.2.14.3 for more information.



ESM-QM77

Item	Options	Description
ERP Deep S5	Enabled Disabled[Default]	Deep S5 for power saving.

3.6.2.14.1 Serial Port 1 Configuration

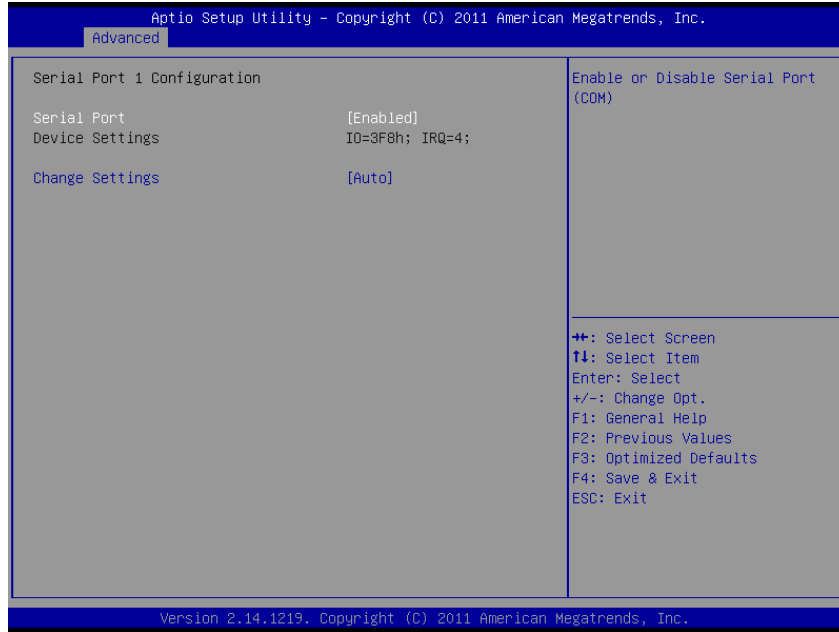

Item	Option	Description
Serial Port	Enabled, Disabled[Default]	Enable or Disable Serial Port (COM)
Change Settings	Auto[Default] IO=3F8h; IRQ=4, IO=3F8h; IRQ=3,4,5,6,7,9,10,11,12 IO=2F8h; IRQ=3,4,5,6,7,9,10,11,12 IO=3E8h; IRQ=3,4,5,6,7,9,10,11,12 IO=2E8h; IRQ=3,4,5,6,7,9,10,11,12	Select an optimal setting for Super IO device.

3.6.2.14.2 Serial Port 2 Configuration

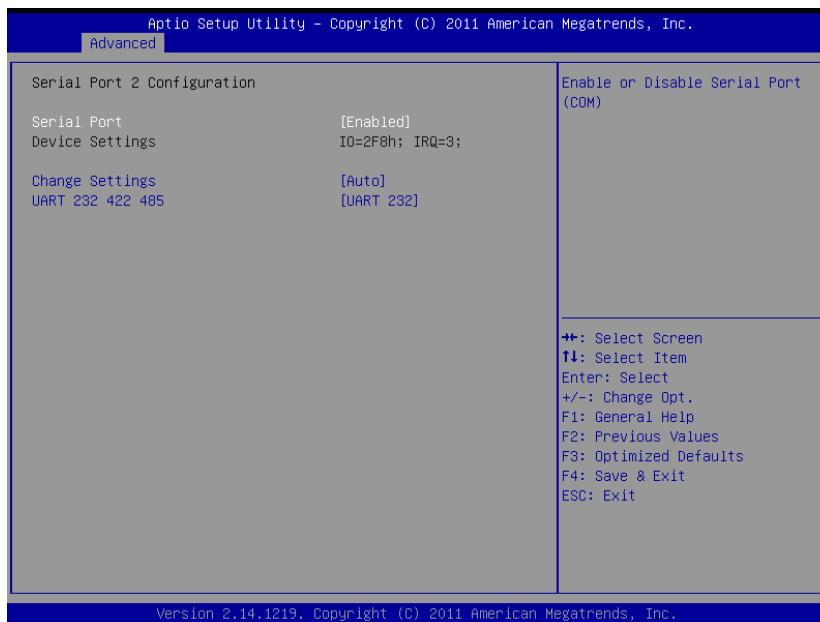

Item	Option	Description
Serial Port	Enabled, Disabled [Default]	Enable or Disable Serial Port (COM)
Change Settings	Auto[Default] IO=2F8h; IRQ=3 IO=3F8h; IRQ=3,4,5,6,7,9,10,11,12 IO=2F8h; IRQ=3,4,5,6,7,9,10,11,12 IO=3E8h; IRQ=3,4,5,6,7,9,10,11,12 IO=2E8h; IRQ=3,4,5,6,7,9,10,11,12	Select an optimal setting for Super IO device.
UART 232 422 485	UART 232[Default] UART 422 UART 485	Change the Serial Port as RS232/422/485.

ESM-QM77

3.6.2.14.3 Parallel Port Configuration

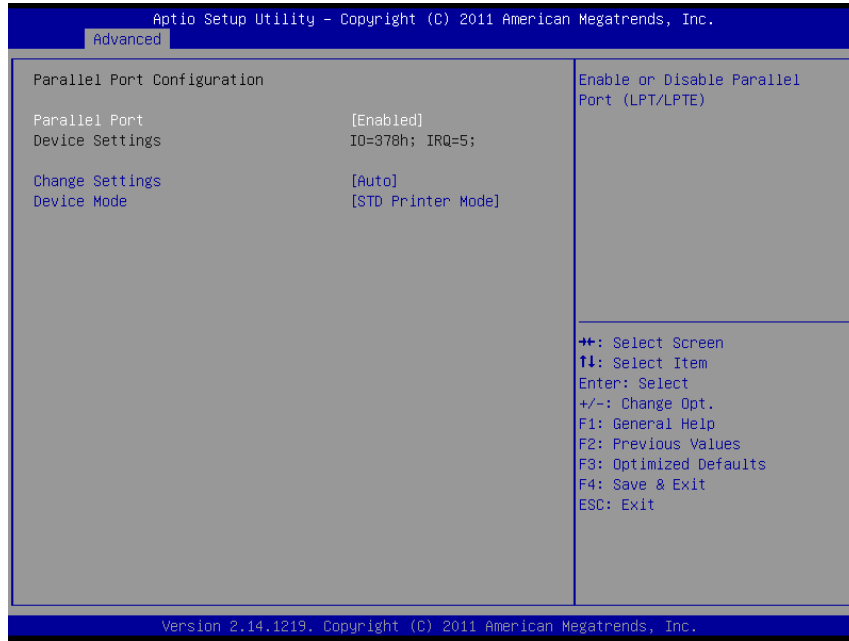

Item	Option	Description
Parallel Port	Enabled[Default] Disabled	Enable or Disable Parallel Port (LPT/LPTE).
Change Settings	Auto[Default] IO=378h; IRQ=5 IO=378h; IRQ=5,6,7,9,10,11,12 IO=278h; IRQ=5,6,7,9,10,11,12 IO=3BCh; IRQ=5,6,7,9,10,11,12	Select an optimal setting for super IO device.
Device Mode	STD Printer Mode[Default] SPP Mode EPP-1.9 and SPP Mode EPP-1.7 and SPP Mode ECP Mode ECP and EPP 1.9 Mode ECP and EPP 1.7 Mode	Change the Printer Port mode.

3.6.2.15 Intel® Smart Connect Technology



Item	Options	Description
ISCT Configuration	Enabled Disabled[Default]	Enable/Disable ISCT Configuration.

3.6.2.16 CPU PPM Configuration

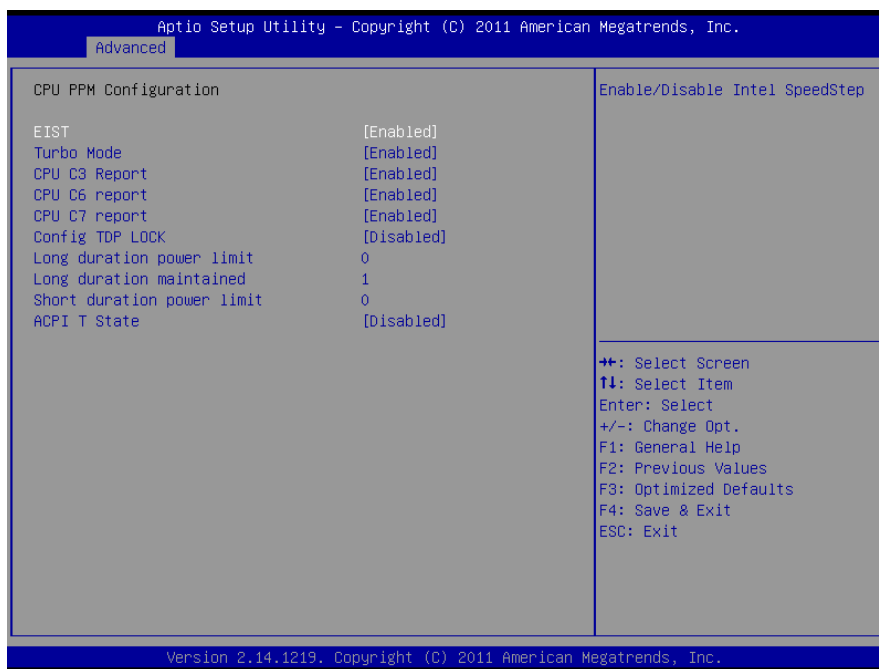

ESM-QM77

Item	Option	Description
EIST	Disabled Enabled[Default]	Enable or Disable Intel SpeedStep.
Turbo Mode		Turbo Mode.
CPU C3/6/7 Report		Enable or Disable CPU C3(ACPI C2)/C6(ACPI C3)/C7(ACPI C3) report to OS.
Config TDP LOCK	Disabled[Default] Enabled	Lock the Config TDP Control register.
Long duration power limit	Long duration power limit in Watts, 0 means use factory default.	
Long duration maintained	Time window which the long duration power is maintained.	
Short duration power limit	Short duration power limit in Watts, 0 means use factory default.	
ACPI T State	Disabled[Default] Enabled	Enable/Disable ACPI T state support.

3.6.3 Chipset



3.6.3.1 PCH-IO Configuration

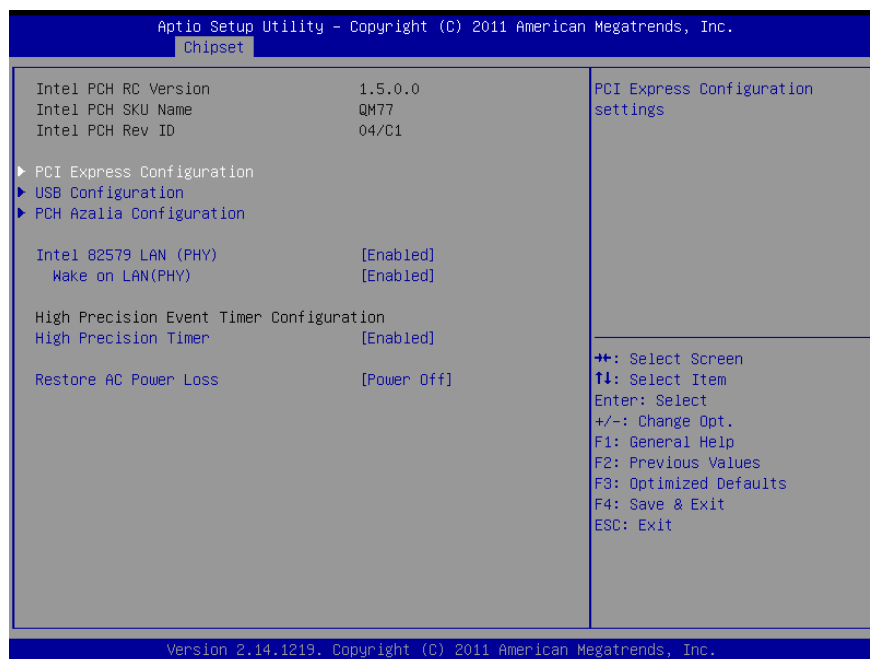

Item	Option	Description
PCI Express Configuration	PCI Express Configuration settings.	
USB Configuration	USB Configuration settings.	
PCH Azalia Configuration	PCH Azalia Configuration settings.	
Intel 82579 LAN (PHY)	Disabled Enabled[Default]	Enable or disable onboard NIC.
Wake on LAN	Disabled Enabled[Default]	Enable or disable integrated LAN to wake the system. (The Wake On LAN cannot be disabled if ME is on at Sx state.)
High Precision Timer	Disabled Enabled[Default]	Enable or Disable the High Precision Event Timer.
Restore AC Power Loss	Power Off[Default] Power On Last State	Select AC power state when power is re-applied after a power failure.

3.6.3.1.1 PCI Express Configuration

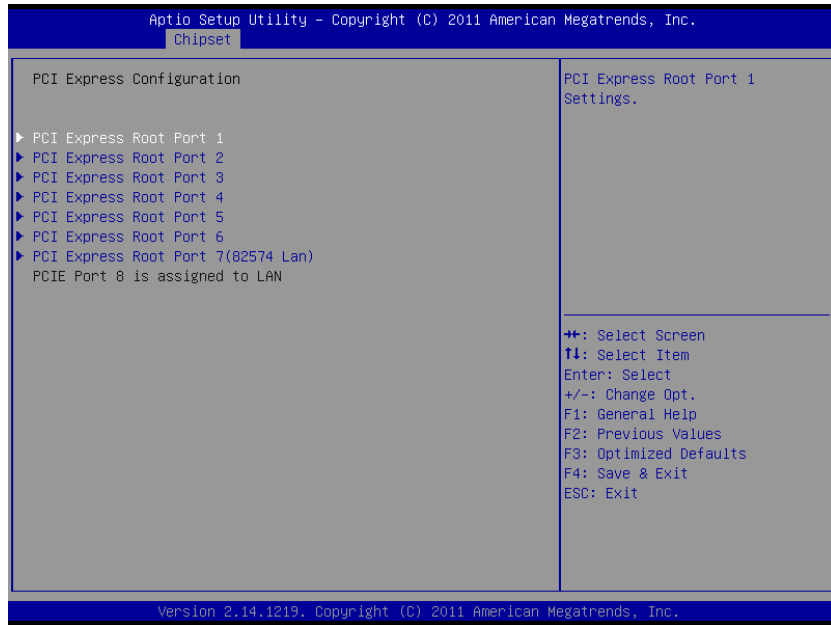

3.6.3.1.1.1 PCI Express Root Port 1/6/7

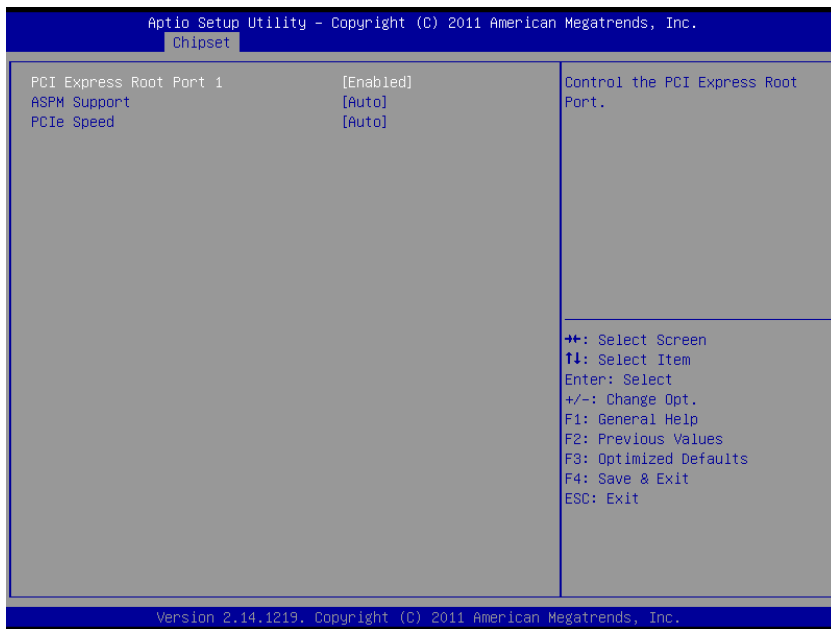

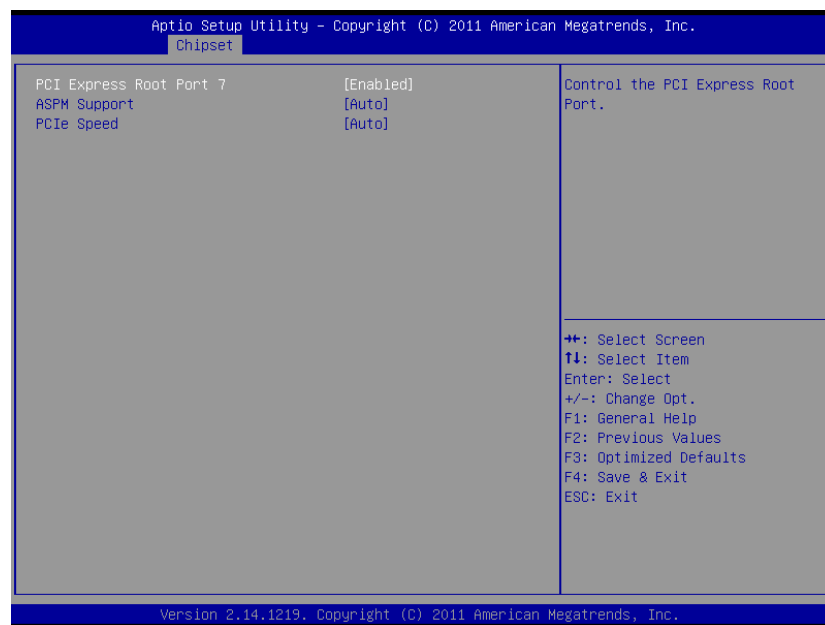
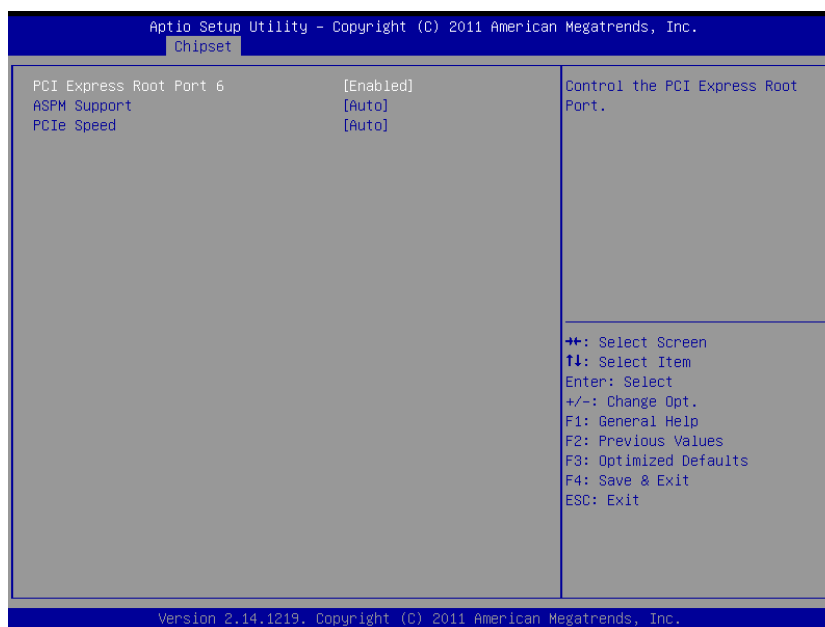

Item	Option	Description
PCI Express Root Port 1/6/7	Disabled Enabled[Default]	Control the PCI Express Root Port.
ASPM Support	Disabled L0s L1 L0sL1 Auto[Default]	Set the ASPM Level: Force L0s – Force all links to L0s State : AUTO – BIOS auto configure : DISABLE – Disables ASPM.
PCIe Speed	Auto[Default] Gen1 Gen2	Select PCI Express port speed.

ESM-QM77

3.6.3.1.1.2 PCI Express Root Port 2/3/4/5

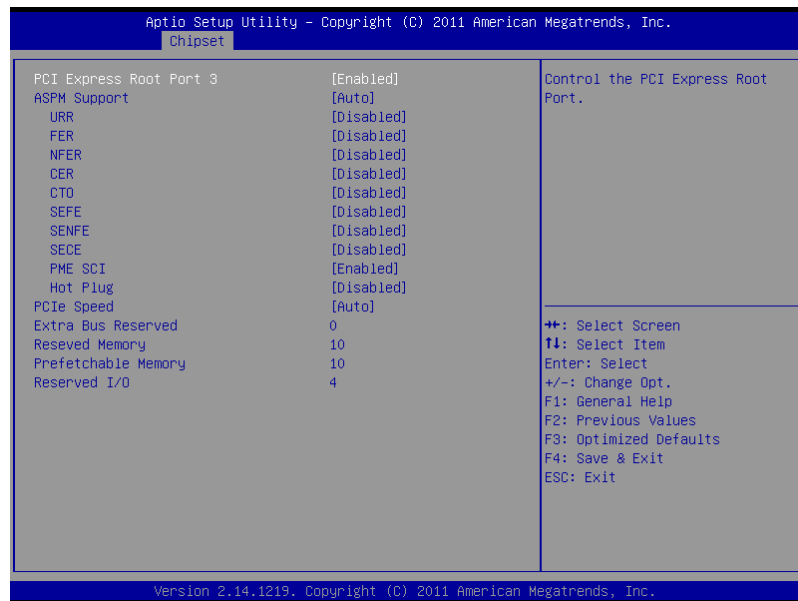
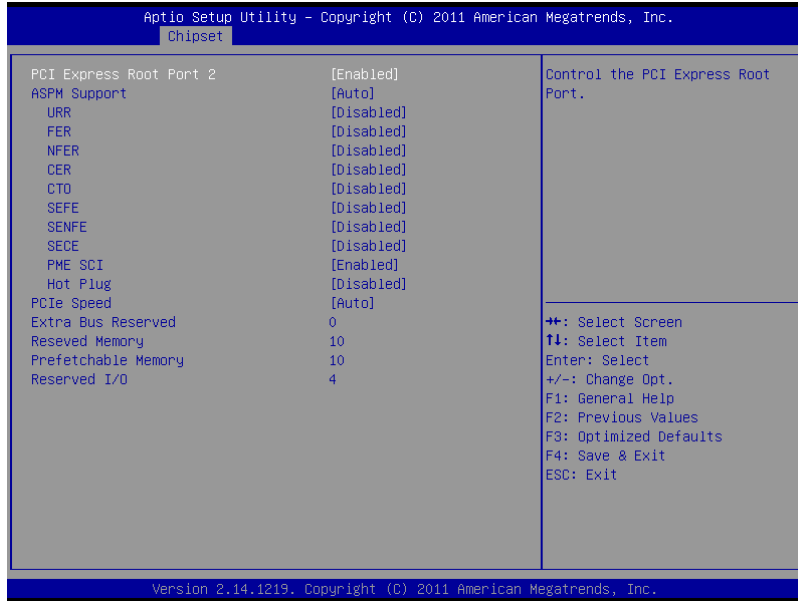

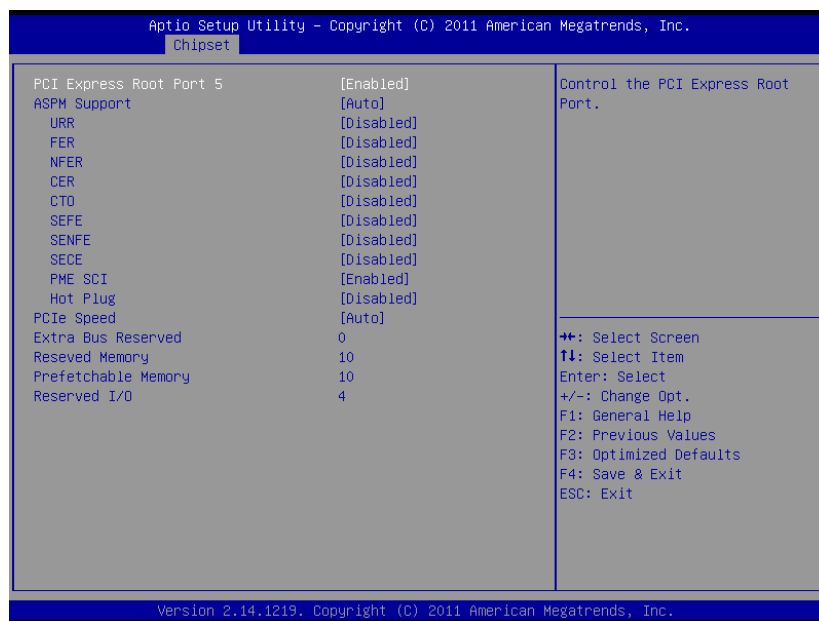
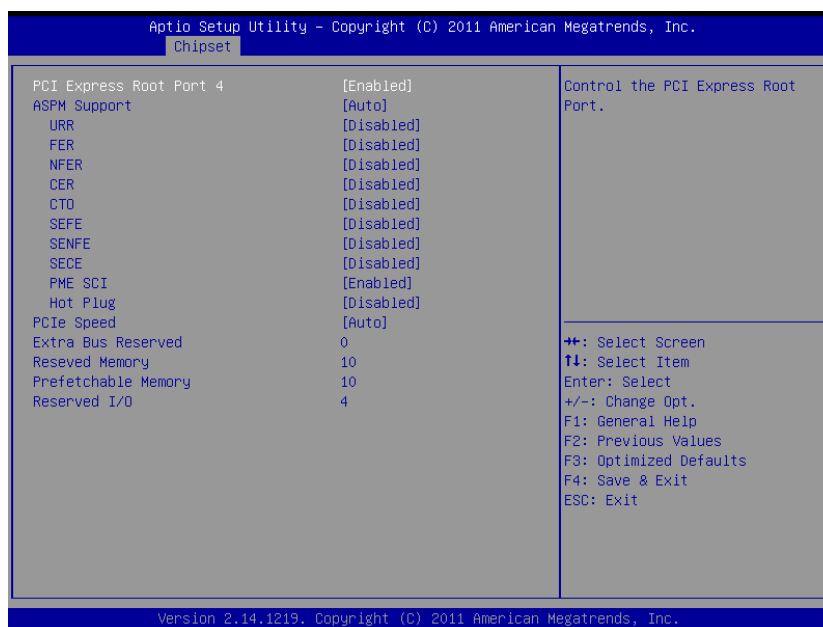

Item	Option	Description
PCI Express Root Port 2/3/4/5	Disabled Enabled [Default]	Control the PCI Express Root Port.
ASPM Support	Disabled L0s L1 L0sL1 Auto [Default]	Set the ASPM Level: Force L0s – Force all links to L0s State : AUTO – BIOS auto configure : DISABLE – Disables ASPM.
URR	Disabled [Default] Enabled	Enable or disable PCI Express Unsupported Request Reporting.
FER	Disabled [Default] Enabled	Enable or disable PCI Express Device Fatal Error Reporting.
NFER	Disabled [Default]	Enable or disable PCI Express

ESM-QM77

	Enabled	Device Non-Fatal Error Reporting.
CER	Disabled[Default] Enabled	Enable or disable PCI Express Device Correctable Error Reporting.
CTO	Disabled[Default] Enabled	Enable or disable PCI Express Completion Timer TO.
SEFE	Disabled[Default] Enabled	Enable or disable Root PCI Express System Error on Fatal Error.
SENF	Disabled[Default] Enabled	Enable or disable Root PCI Express System Error on Non-Fatal Error.
SECE	Disabled[Default] Enabled	Enable or disable Root PCI Express System Error on Correctable Error.
PME SCI	Disabled Enabled[Default]	Enable or disable PCI Express PME SCI.
Hot Plug	Disabled[Default] Enabled	Enable or disable PCI Express Hot Plug.
PCIe Speed	Auto[Default] Gen1 Gen2	Select PCI Express port speed.
Extra Bus Reserved	0	Extra Bus Reserved for bridges behind this Root Bridge.
Reserved Memory	10	Reserved Memory Range for this Root Bridge.
Prefetchable Memory	10	Prefetchable Memory Range for this Root Bridge.
Reserved I/O	4K[Default]/8K/12K/16K/20K	Reserved I/O (4K/8K/12K/16K/20K) Range for this Root Bridge.

3.6.3.1.2 USB Configuration

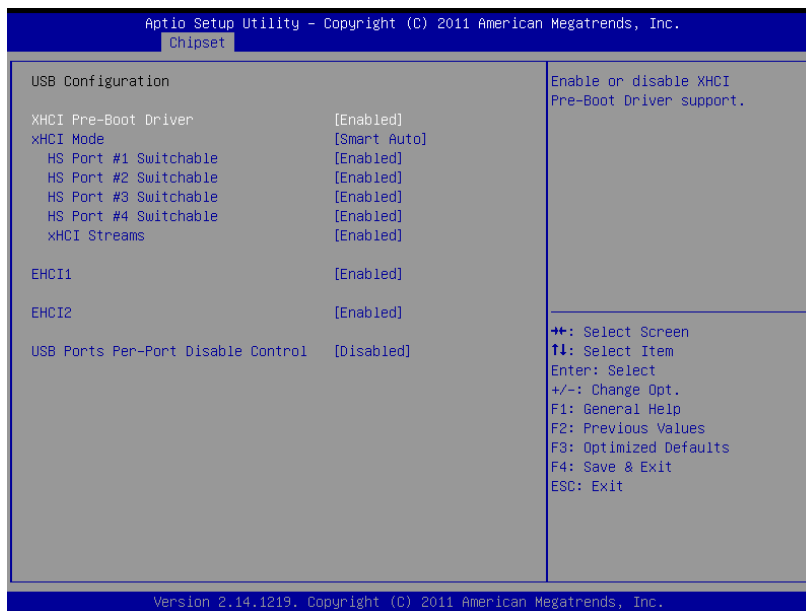

Item	Option	Description
XHCI Pre-Boot Driver	Disabled Enabled[Default]	Enable or disable XHCI Pre-Boot Driver support.
xHCI Mode	Smart Auto[Default] Auto Enabled Disabled	Mode of operation of xHCI controller.
HS Port #1/#2/#3/#4 Switchable	Disabled Enabled[Default]	Allows for HS port switching between xHCI and EHCI. If disabled, port is routed to EHCI. If HS port is routed to xHCI, the corresponding SS port is enabled.
xHCI Streams	Disabled Enabled[Default]	Enable or disable xHCI Maximum Primary Stream Array Size.
EHCI1/2	Disabled Enabled[Default]	Control the USB EHCI (USB 2.0) functions. One EHCI controller must always be enabled.
USB Ports Per-Port Disable Control	Disabled[Default] Enabled	Control each of the USB ports (0~13) disabling.

3.6.3.1.3 PCH Azalia Configuration

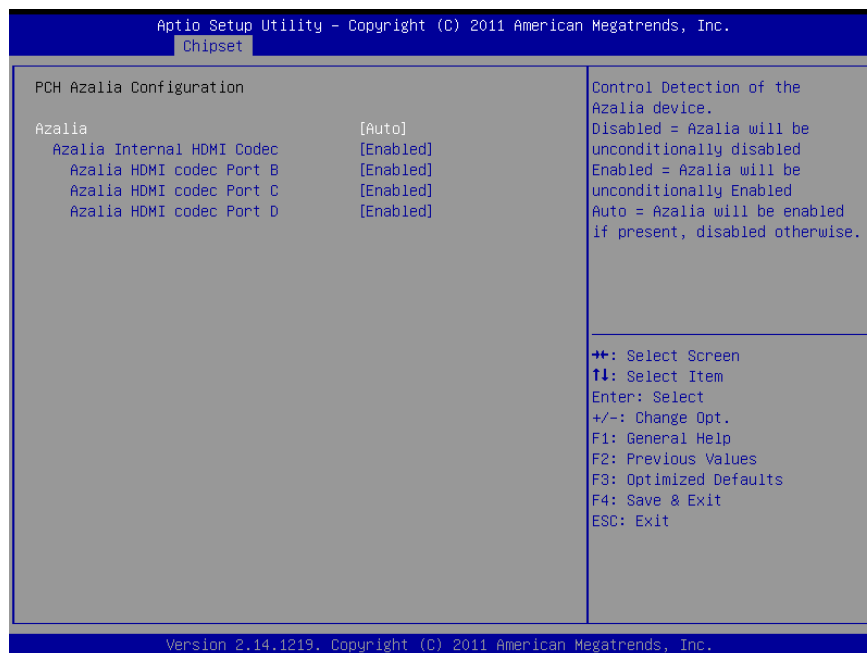

Item	Option	Description
Azalia	Disabled Enabled Auto[Default]	Control Detection of the Azalia device. Disabled = Azalia will be unconditionally disabled. Enabled = Azalia will be unconditionally Enabled. Auto = Azalia will be enabled if present, disabled otherwise.
Azalia Internal HDMI Codec	Disabled Enabled[Default]	Enable or disable internal HDMI codec for Azalia.
Azalia HDMI codec Port B/C/D	Disabled Enabled[Default]	Enable or disable internal HDMI codec Port for Azalia.

3.6.3.2 System Agent (SA) Configuration



Item	Option	Description
VT-d	Disabled Enabled[Default]	Check to enable VT-d function on MCH.
CHAP Device (B0:D7:F0)	Disabled[Default] Enabled	Enable or disable SA CHAP Device.
Thermal Device (B0:D4:F0)		Enable or disable SA Thermal Device.
Memory Configuration	Memory Configuration Parameters.	
GT – Power Management Control	GT – Power Management Control Options.	

3.6.3.2.1 Memory Configuration

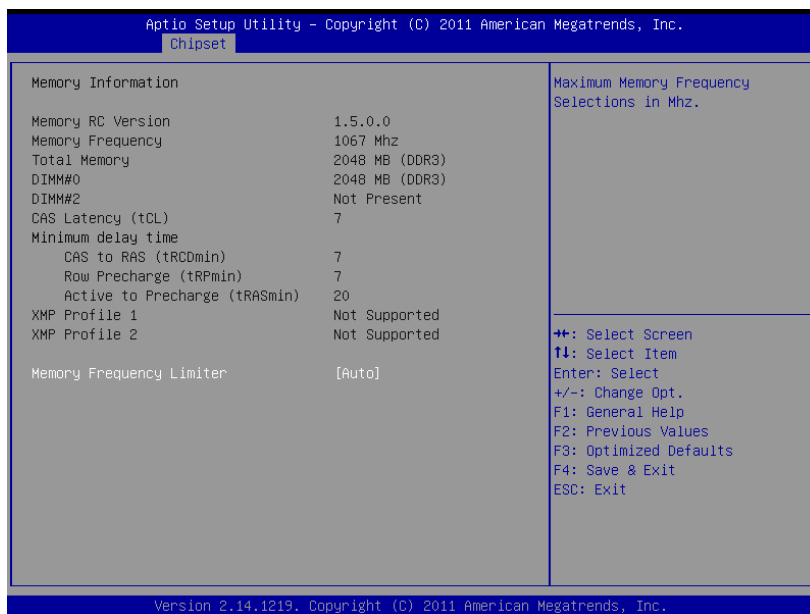

Item	Option	Description
Memory Frequency Limiter	Auto[Default]/1067/1333/1600 /1867/2133/2400/2667	Maximum Memory Frequency Selections in Mhz.

3.6.3.2.2 GT – Power Management Configuration



Item	Option	Description
GT OverClocking Support	Disabled[Default] Enabled	Enable or disable GT OverClocking Support.

3.6.3.3 Graphics Configuration

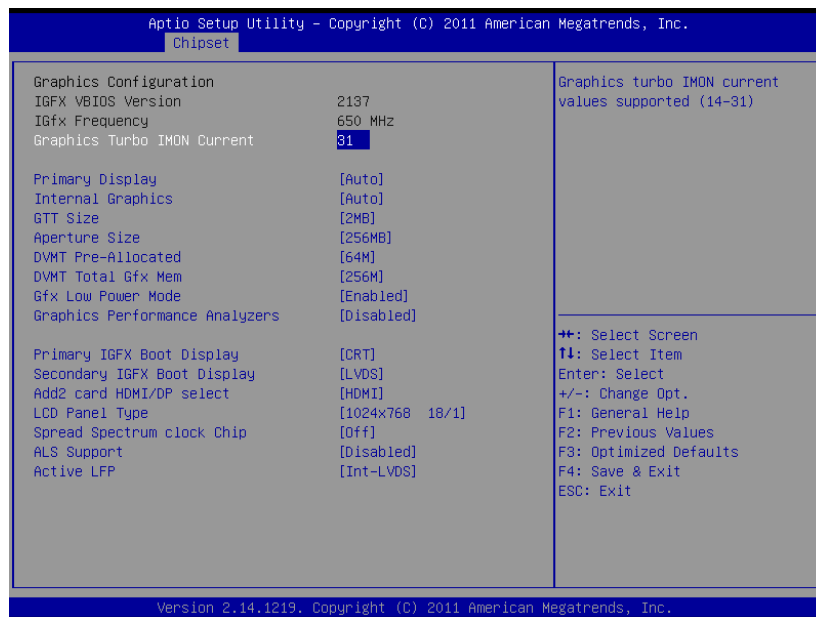

Item	Option	Description
Graphics Turbo IMON Current	14 ~31 [Default]	Graphics turbo IMON current values supported (14 -31).
Primary Display	Auto [Default] IGFX PEG PCI	Select which of IGFX/PEG/PCI Graphics device should be Primary Display Or select SG for Switchable Gfx.
Internal Graphics	Auto [Default] Disabled Enabled	Keep IGD enabled based on the setup options.
GTT Size	1MB 2MB [Default]	Select the GTT size
Aperture Size	128MB 256MB [Default] 512MB	Select the Aperture Size
DVMT Pre-Allocated	[32M] [64M] [Default] [96M] [128M] [160M] [192M] [224M] [256M] [288M] [320M] [352M] [384M] [416M] [448M] [480M] [512M] [1024M]	Select DVMT 5.0 Pre-Allocated (Fixed) Graphics Memory size used by the Internal Graphics Device.
DVMT Total Gfx Mem	[128M] [256M] [Default] [MAX]	Select DVMT5.0 Total Graphic Memory size used by the Internal Graphics Device.
Gfx Low Power Mode	Disabled Enabled [Default]	This option is applicable for SFF only.
Graphics Performance Analyzers	Disabled [Default] Enabled	Enable or disable Intel Graphics Performance Analyzers Counters.
Primary IGFX Boot Display	VBIOS Default	Select the Video Device which

ESM-QM77

	<p>CRT[Default] LVDS Port-B (Add2 card) Port-C HDMI Port-D DP</p>	<p>will be activated during POST. This has no effect if external graphics present. Secondary boot display selection will appear based on your selection. VGA modes will be supported only on primary display.</p>
<p>Secondary IGFX Boot Display</p>	<p>VBIOS Default CRT LVDS[Default] Port-B (Add2 card) Port-C HDMI Port-D DP</p>	<p>Select Secondary Display Device.</p>
<p>Add2 Card HDMI/DP select</p>	<p>HDMI[Default] DP</p>	<p>Select Add2 card display as HDMI or DP.</p>
<p>LCD Panel Type</p>	<p>VBIOS Default 640x480 18/1 800x600 18/1 1024x768 18/1[Default] 1280x1024 24/2 1024x600 18/1 800x600 18/1 1600x1200 24/2 1366x768 24/1 1680x1050 24/2 1920x1200 24/2 1440x900 24/2 1600x1200 24/2 1024x768 24/1 1280x800 18/1 1920x1080 24/2 2048x1536 24/2</p>	<p>Select LCD panel used by Internal Graphics Device by selecting the appropriate setup item.</p>
<p>Spread Spectrum clock Chip</p>	<p>Off[Default] Hardware Software</p>	<p>>>Hardware : Spread is controlled by chip;>>Software : Spread is controlled by BIOS.</p>
<p>ALS Support</p>	<p>Disabled[Default] Enabled</p>	<p>Valid only for ACPI. Legacy= ALS Support through the IGD INT10 function. ACPI= ALS support through an ACPI ALS driver.</p>
<p>Active LFP</p>	<p>No LVDS Int-LVDS[Default] SDVO LVDS</p>	<p>Select the Active LFP Configuration. No LVDS: VBIOS does not enable LVDS. Int-LVDS: VBIOS enables LVDS driver by Integrated encoder. SDVO LVDS: VBIOS enables LVDS driver by SDVO encoder. eDP Port-A: LFP Driven by Int-DisplayPort encoder from Port-A. eDP Port-D: LFP Driven by Int-DisplayPort encoder from Port-D (through PCH).</p>

3.6.4 Boot

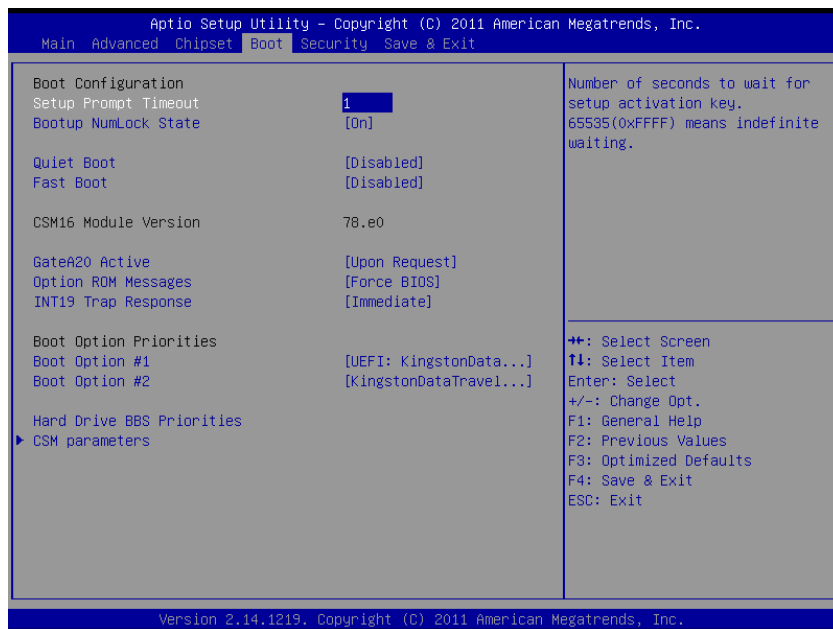

Item	Option	Description
Setup Prompt Timeout	1~ 65535	Number of seconds to wait for setup activation key. 65535(0xFFFF) means indefinite waiting.
Bootup NumLock State	On[Default] Off	Select the Keyboard NumLock state
Quiet Boot	Disabled[Default] Enabled	Enables or disables Quiet Boot option
Fast Boot	Disabled[Default] Enabled	Enables or disables boot with initialization of a minimal set of devices required to launch active boot option. Has no effect for BBS boot options.
GateA20 Active	Upon Request[Default] Always	UPON REQUEST – GA20 can be disabled using BIOS services. ALWAYS – do not allow disabling GA20; this option is useful when any RT code is executed above 1MB.
Option ROM Messages	Force BIOS[Default] Keep Current	Set display mode for Option ROM.
Interrupt 19 Capture	Disabled Enabled[Default]	BIOS reaction on INT19 trapping by Option ROM: IMMEDIATE – execute the trap right away; POSTPONED – execute the trap during legacy boot.
Boot Option Priorities	Sets the system boot order	

ESM-QM77

Hard Drive BBS Priorities	Set the order of the legacy devices in this group
----------------------------------	---

3.6.4.1 CSM parameters



Item	Option	Description
Launch PXE OpROM policy	Do not launch [Default] UEFI only Legacy only	Controls the execution of UEFI and Legacy PXE OpROM.
Launch Storage OpROM policy	Do not launch UEFI only Legacy only [Default]	Controls the execution of UEFI and Legacy Storage OpROM.
Launch Video OpROM policy	Do not launch UEFI only Legacy only [Default]	Controls the execution of UEFI and Legacy Video OpROM.

ESM-QM77

3.6.5 Security



- **Administrator Password**

Set setup Administrator Password

- **User Password**

Set User Password

3.6.6 Save and exit

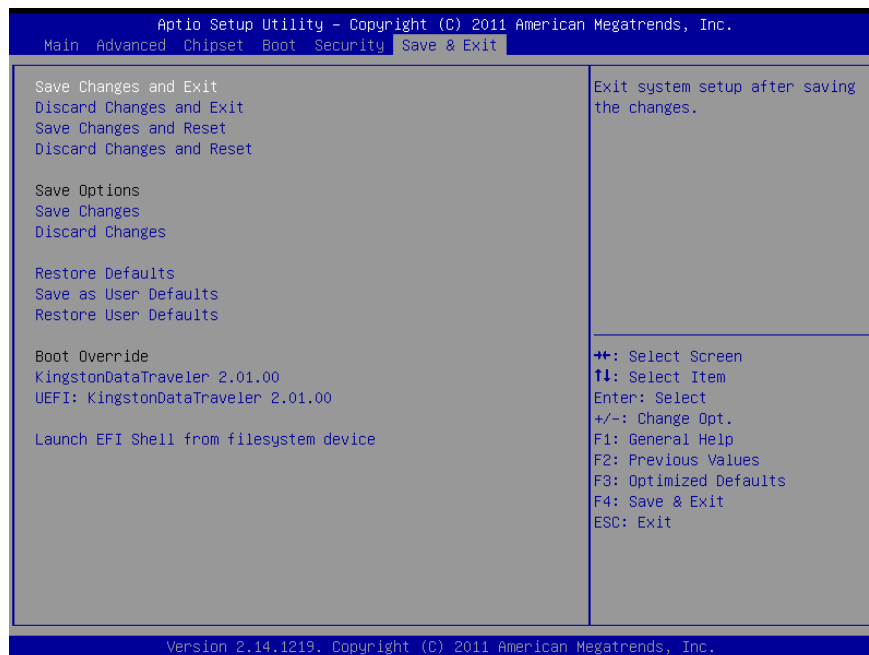

3.6.6.1 Save Changes and Exit

Exit system setup after saving the changes.

3.6.6.2 Discard Changes and Exit

Exit system setup without saving any changes.

ESM-QM77

3.6.6.3 *Save Changes and Reset*

Reset the system after saving the changes.

3.6.6.4 *Discard Changes and Reset*

Any changes made to BIOS settings during this session of the BIOS setup program are discarded. The setup program then exits and reboots the controller.

3.6.6.5 *Save Changes*

Save Changes done so far to any of the setup options.

3.6.6.6 *Discard Changes*

Discard Changes done so far to any of the setup options.

3.6.6.7 *Restore Defaults*

This option restores all BIOS settings to the factory default. This option is useful if the controller exhibits unpredictable behavior due to an incorrect or inappropriate BIOS setting.

3.6.6.8 *Save as User Defaults*

This option saves a copy of the current BIOS settings as the User Defaults. This option is useful for preserving custom BIOS setup configurations.

3.6.6.9 *Restore User Defaults*

This option restores all BIOS settings to the user defaults. This option is useful for restoring previously preserved custom BIOS setup configurations.

3.6.6.10 *Launch EFI Shell from filesystem device*

Attempts to Launch EFI Shell application (Shellx64.efi) from one of the available filesystem devices.

4. Drivers Installation



Note: Installation procedures and screen shots in this section are for your reference and may not be exactly the same as shown on your screen.

4.1 Install Chipset Driver (For Intel QM77)

Insert the Supporting DVD-ROM to DVD-ROM drive, and it should show the index page of the products automatically. If not, locate Index.htm and choose the product from the menu left, or link to `\\Driver_Chipset\Intel\ESM-QM77_INF`.



Note: The installation procedures and screen shots in this section are based on Windows 7 operation system. If the warning message appears while the installation process, click Continue to go on.

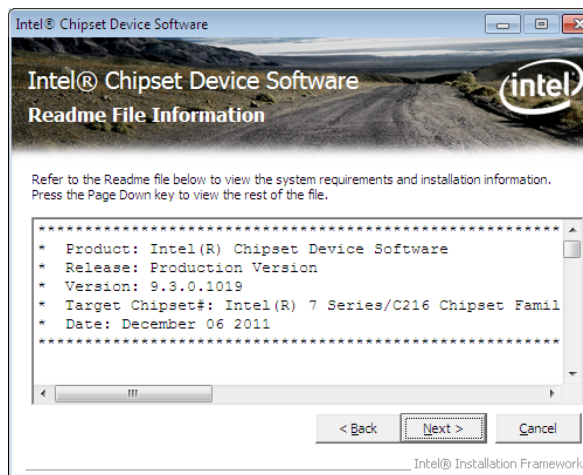

Step 3. Click Next.

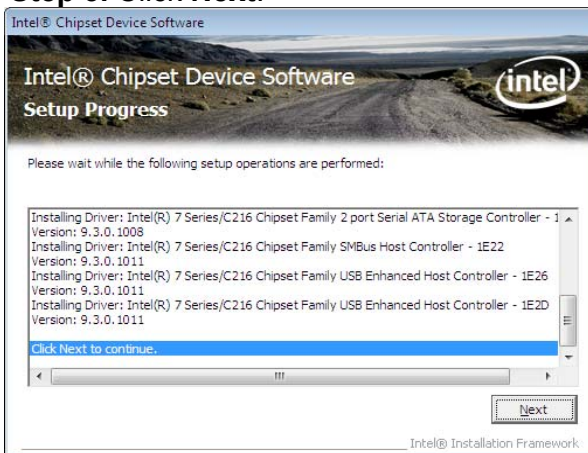
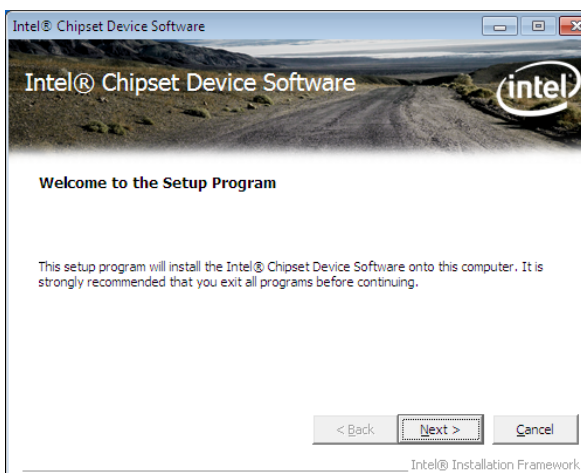

Step 4. Click Next.

Step1. Click Next.



Step 2. Click Yes.



Step 5. Click Finish to complete setup.

4.2 Install Display Driver (For Intel QM77)

Insert the Supporting DVD-ROM to DVD-ROM drive, and it should show the index page of the products automatically. If not, locate Index.htm and choose the product from the menu left, or link to `\\VGA\ESM-QM77_VGA`.



Note: The installation procedures and screen shots in this section are based on Windows 7 operation system.

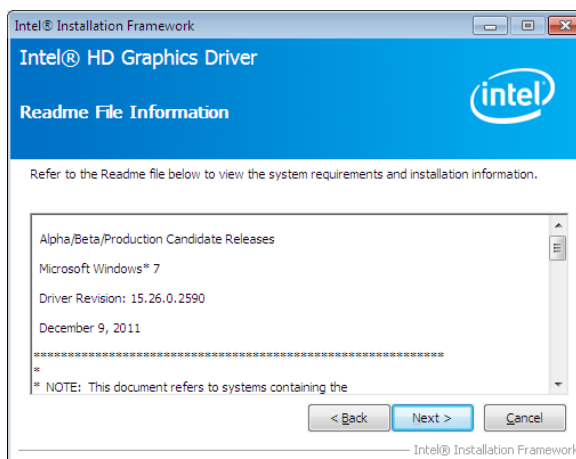

Step 3. Click Next.

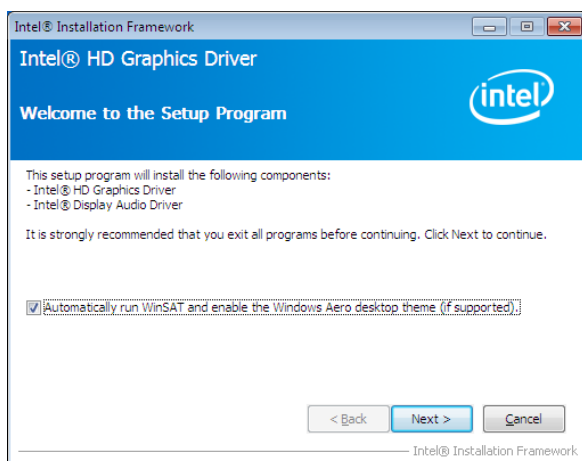

Step 1. Click Next to continue installation.

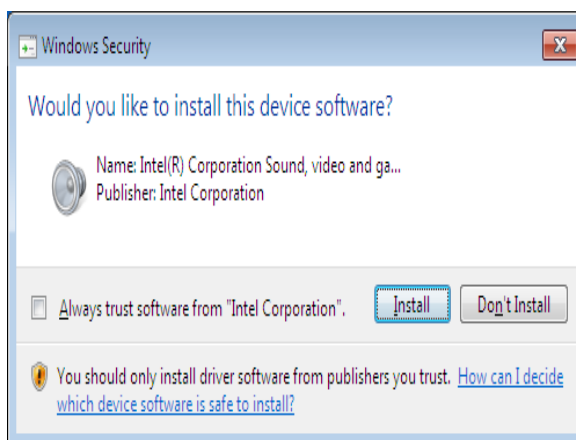

Step 4. Click Install.

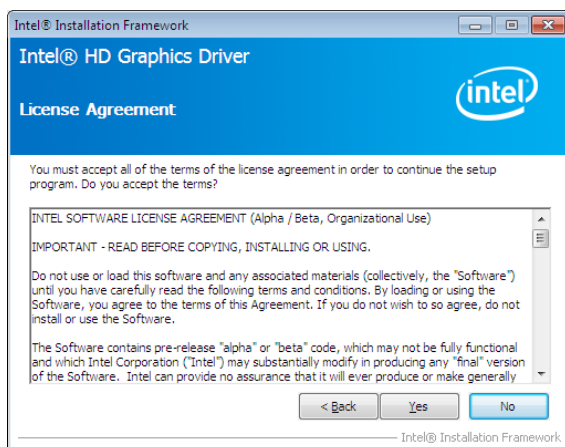

Step 2.
Click **Yes** to accept license agreement.

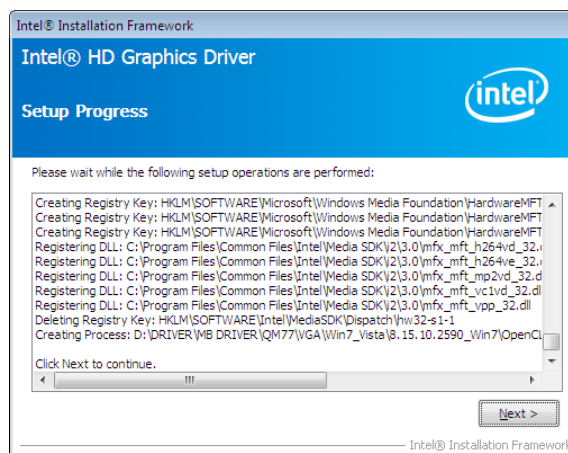

Step 5. Click Next.

ESM-QM77

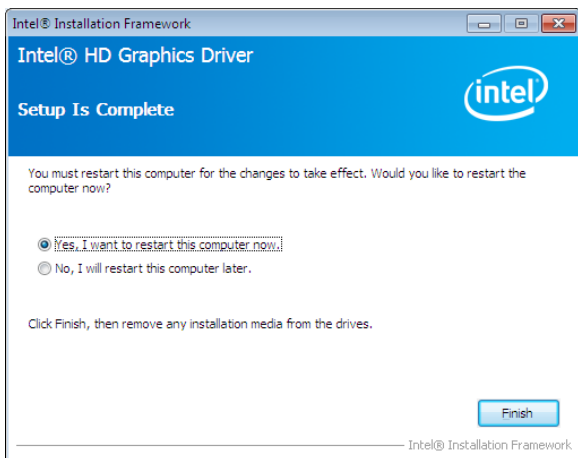

Step 6. Click **Finish** to complete setup.

4.3 Install LAN Driver (For Intel 82579)

Insert the Supporting DVD-ROM to DVD-ROM drive, and it should show the index page of the products automatically. If not, locate Index.htm and choose the product from the menu left, or link to **\Driver_Gigabit\Intel\82579\ESM-QM77_intel82579**.



Note: The installation procedures and screen shots in this section are based on Windows 7 operation system.

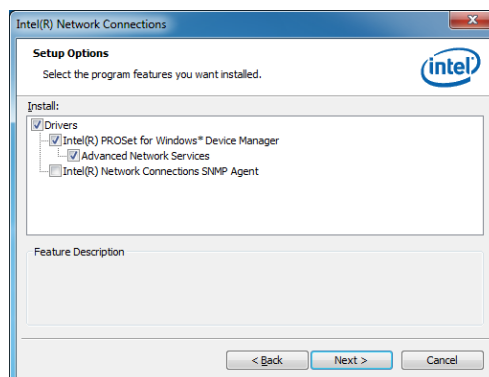

Step 4. Click **Next** after selecting programs to install.

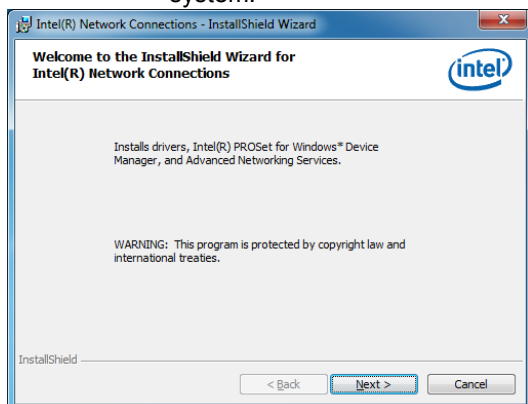

Step 2. Click **Next**.

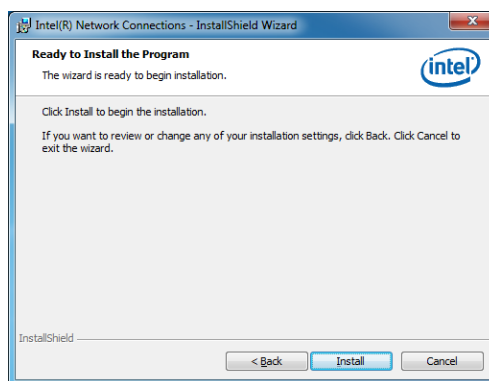

Step 5. Click **Install** to begin installation.



Step 3. Click **Next** to accept licence agreement.

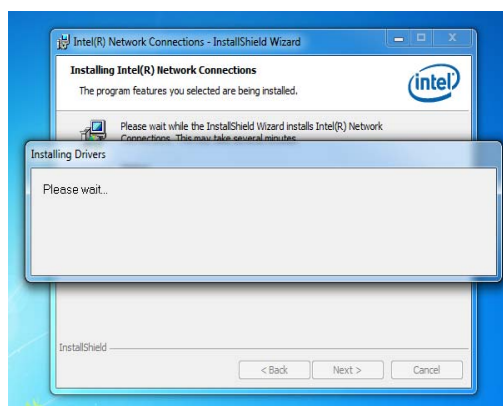

Step 6. **Wait** while installing.

ESM-QM77

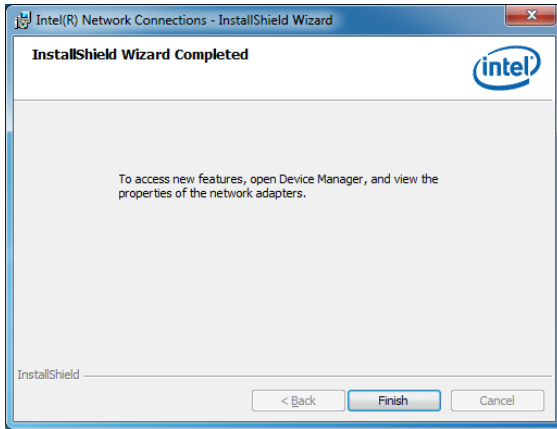

Step 7. Click **Finish** to complete installation.

4.4 Install USB 3.0 Driver (For Intel QM77)

Insert the Supporting DVD-ROM to DVD-ROM drive, and it should show the index page of the products automatically. If not, locate Index.htm and choose the product from the menu left, or link to \Utility\ESM-QM77_USB 3.0.



Note: The installation procedures and screen shots in this section are based on Windows 7 operation system. If the warning message appears while the installation process, click Continue to go on.

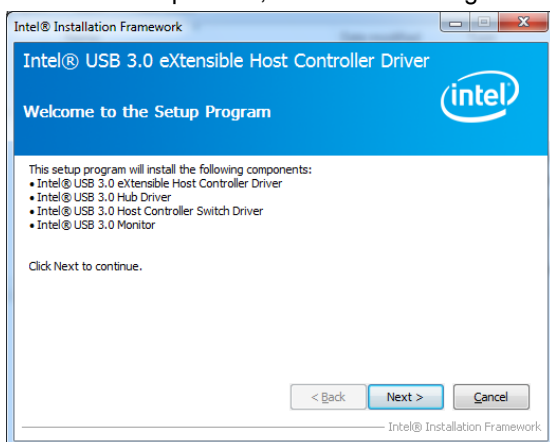

Step 1. Click **Next** to start installation.

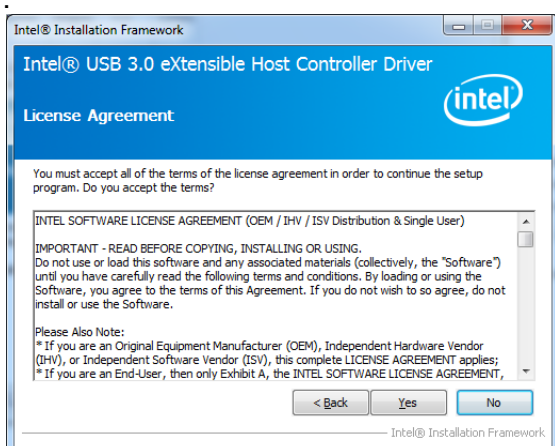

Step 2. Click **Yes**.

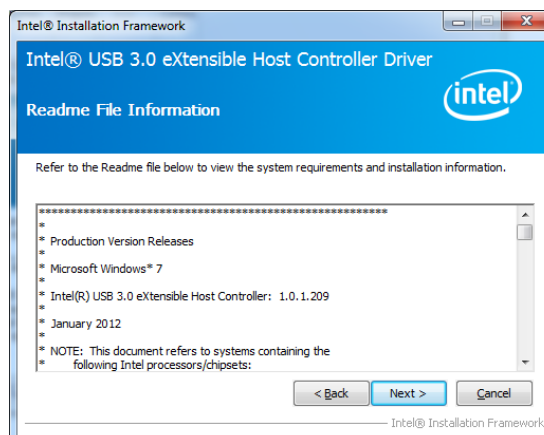

Step 3. Click **Next** to continue installation.

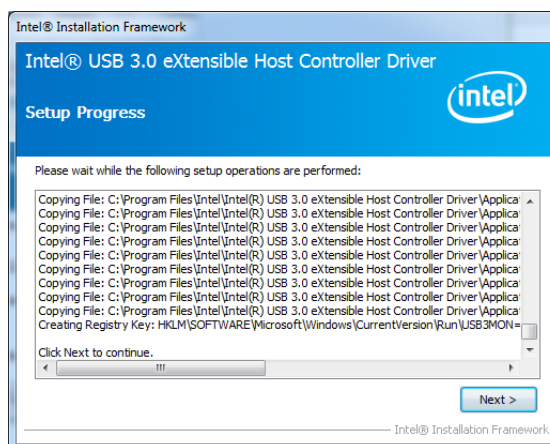

Step 4. Click **Next** to continue installation.

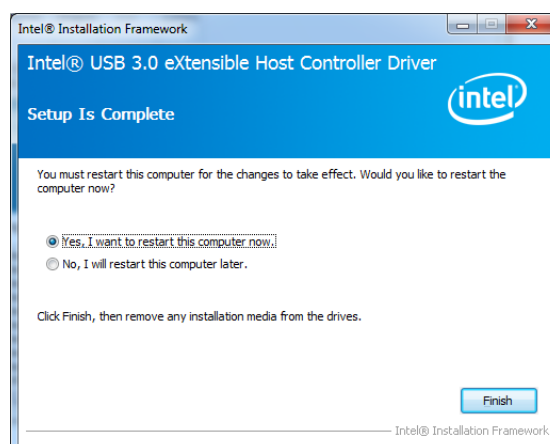

Step 5. Click **Finish** to complete setup.

4.5 Install ME Driver (For Intel QM77)

Insert the Supporting DVD-ROM to DVD-ROM drive, and it should show the index page of the products automatically. If not, locate Index.htm and choose the product from the menu left, or link to `\Utility\ESM-QM77_ME_iAMP_vPRO`.



Note: The installation procedures and screen shots in this section are based on Windows 7 operation system. If the warning message appears while the installation process, click Continue to go on.

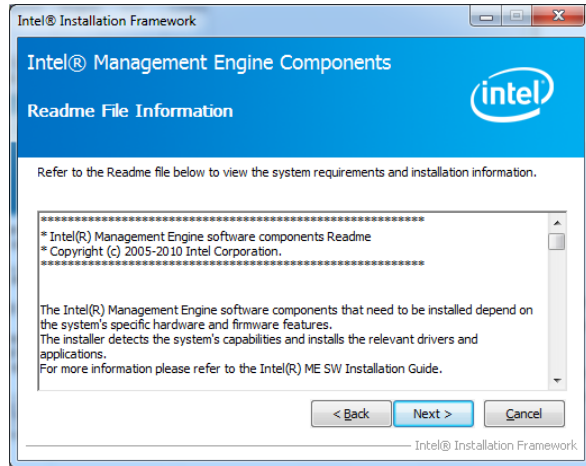

Step 3. Click **Next** to proceed setup.

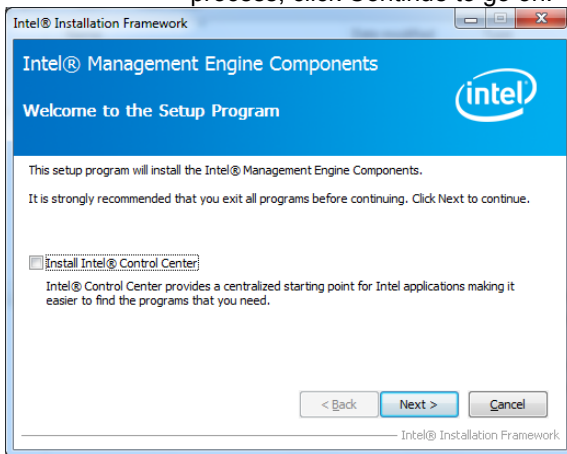

Step1. Click **Next** to start installation.

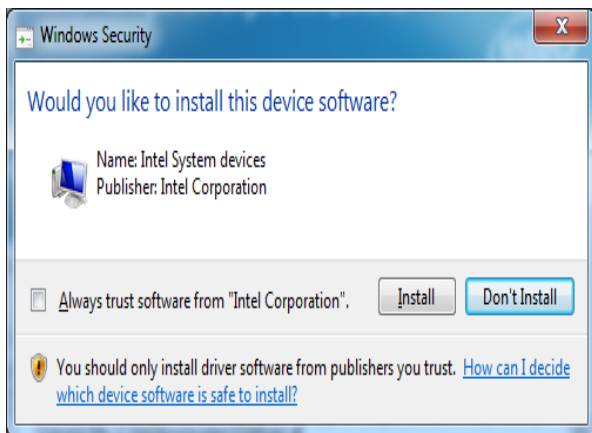

Step 4. Click **Install**.

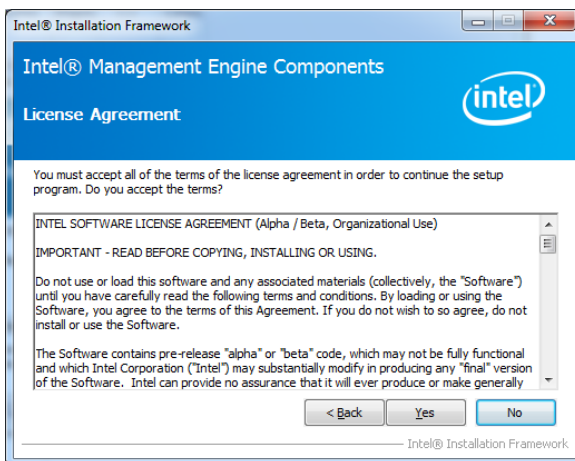

Step 2. Click **Yes** to accept license agreement.

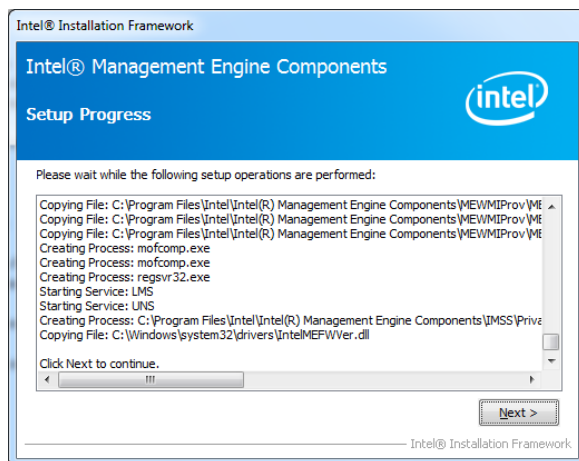

Step 5. Click **Next** to continue.

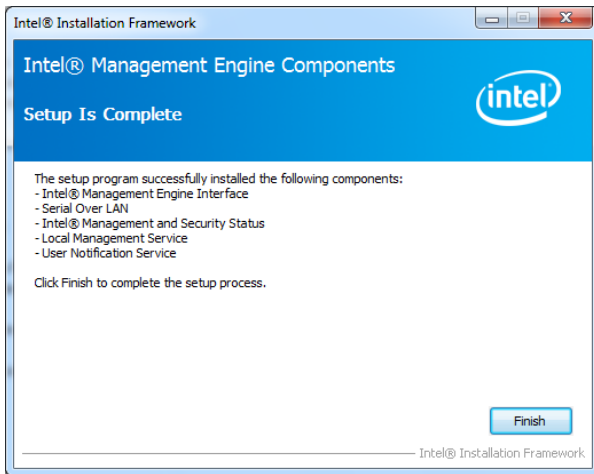

Step 6. Click **Finish** to complete setup.

5. Mechanical Drawing

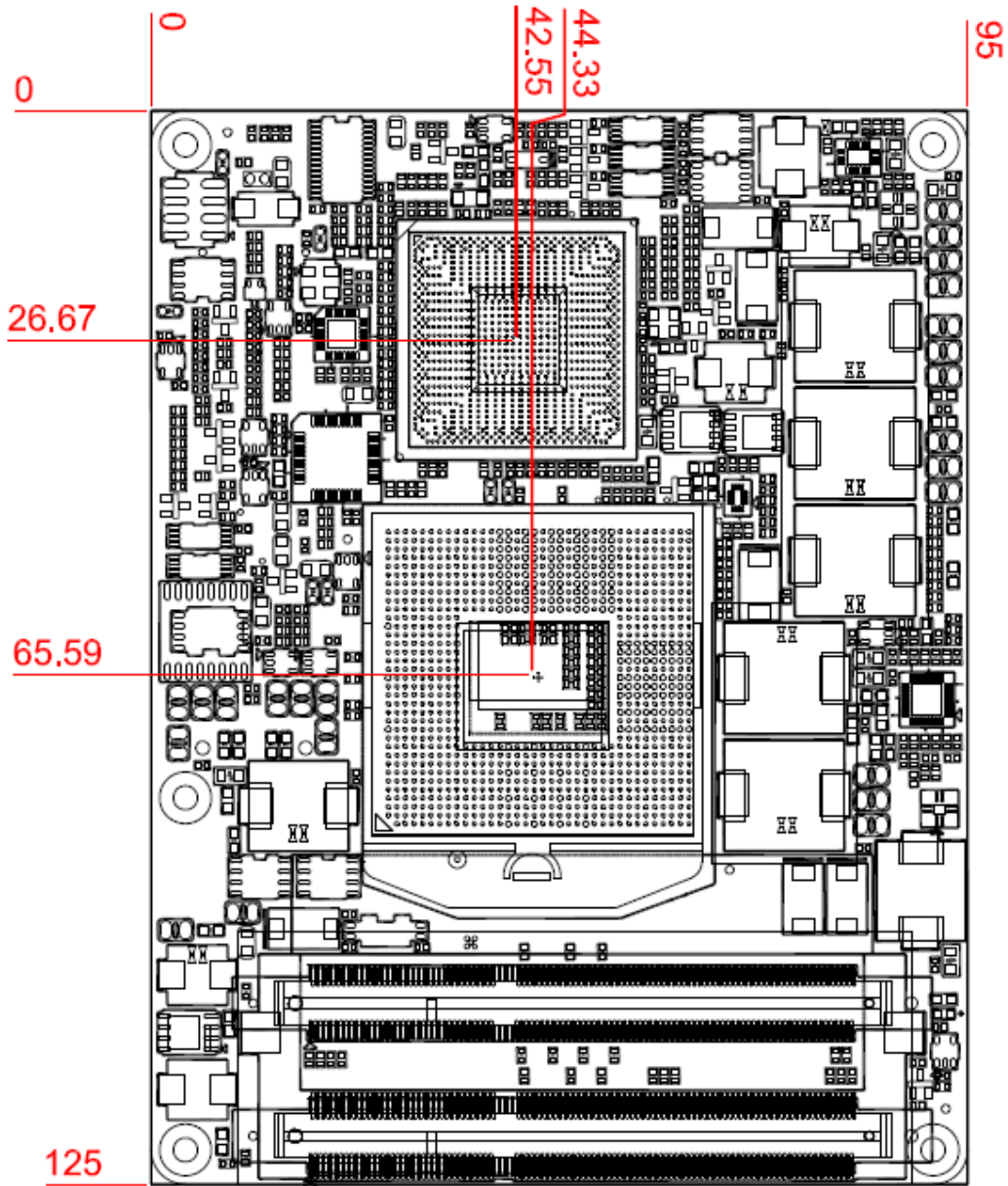

Unit: mm

ESM-QM77

