

Vehicle Mounted Computer

Qualcomm Snapdragon™ 660 octa-core, 2.2 GHz



FM12Q-V

Quick Start Guide

Version 1.0

Document Part No. 9152111109Y

Please read these instructions carefully before using this product, and save this manual for future use.

Contents

Preface	2
1. Unpacking	8
1.1 Standard Package Content.....	8
1.2 Optional Accessories.....	8
2. Components	9
3. Integrated Keypad	12
4. Function Buttons	12
5. Power Cable Installation	14
5.1 Wiring the Power Cable.....	14
5.2 Connecting the Power Cable for Testing.....	14
5.3 Connecting the Power for Installation on the Vehicle.....	15
6. Power on Behavior	17
6.1 Power Control.....	17
6.1.1 Power Button.....	17
6.2 Standby and Wakeup Behavior.....	17
6.2.1 Turn On.....	18
6.2.2 Suspend.....	18
6.2.3 Wake Up.....	18
6.2.4 Turn Off.....	18
7. Ignition Control	19
8. External/ Vehicle Remote Antenna Installation	20
9. Screen Blanking	21
10. Defroster (Optional)	22
11. RAM Mount Installation	24
11.1 Mounting Kit 1 – No Drill Solution.....	24
11.2 Mounting Kit 2 – Drill Solution.....	25
11.3 RAM Mount Assembly.....	26
11.4 Mounting Kit 3 – Keyboard Mounting Installation.....	26
11.5 Keyboard Assembly.....	27
12. Changing Touchscreen Modes	28
Appendix	31
Appendix A: Product Specifications.....	31

Preface

Copyright

No part of this manual may be reproduced, copied, translated, or transmitted in any form or any means, electronic or mechanical, for any purpose, without the written permission of Winmate Inc.

Trademarks

Brand and product names are trademarks or registered trademarks of their respective owners.

**Note:**

Display images shown may vary slightly from actual display. Information in this manual is subject to change without prior notification.

**Note:**

Use the device when located at least 20 cm (7.9 inches) away from the human body.

Disclaimer

Winnmate Inc. reserves the right to make any product changes without notice, including circuits and/or software described or contained in this manual in order to improve design and/or performance. Winnmate Inc. assumes no responsibility or liability for the use of the described product (s), conveys no license or title under any patent, copyright, or masks work rights to these products, and makes no representations or warranties that these products are free from patent, copyright, or mask work right infringement, unless otherwise specified. Applications that are described in this guide are for illustration purposes only. Winnmate Inc. makes no representation or warranty that such application will be suitable for the specified use without further testing or modification.

Warranty

Winnmate Inc. warrants that each of its products is free from material and workmanship defect for a period of one year starting from the invoice date. If the customer discovers a defect, Winnmate Inc. will, at its option, repair or replace the defective product at no charge to the customer, provided it is returned during the warranty period, with transportation charges prepaid. The returned product must be properly packaged in its original packaging to obtain warranty service.

Advisory Conventions

Four types of advisories are used throughout the user manual to provide helpful information or to alert you to the potential for hardware damage or personal injury. These are Notes, Important, Cautions, and Warnings. The following is an example of each type of advisory.



Note:

A note is used to emphasize helpful information



Important:

An important note indicates information that is important for you to know.



Caution A Caution alert indicates potential damage to hardware and explains how to avoid the potential problem.

Attention Une alerte d'attention indique un dommage possible à l'équipement et explique comment éviter le problème potentiel.



Warning! An Electrical Shock Warning indicates the potential harm from electrical hazards and how to avoid the potential problem.

Avertissement! Un Avertissement de Choc Électrique indique le potentiel de chocs sur des emplacements électriques et comment éviter ces problèmes.

FCC Regulations

This device complies with part 15 of the FCC Rules. Operation is subject to the following two conditions: (1) This device may not cause harmful interference, and (2) this device must accept any interference received, including interference that may cause undesired operation.

This device has been tested and found to comply with the limits for a Class B digital device, pursuant to Part 15 of the FCC Rules. These limits are designed to provide reasonable protection against harmful interference in residential installation. This equipment generates uses and can radiate radio frequency energy and, if not installed and used in accordance with the instructions, may cause harmful interference to radio communications. However, there is no guarantee that interference will not occur in a particular installation. If this equipment does cause harmful interference to radio or television reception, which can be determined by turning the equipment off and on, the user is encouraged to try to correct the interference by one or more of the following measures:

- Reorient or relocate the receiving antenna.
- Increase the separation between the equipment and receiver.
- Connect the equipment into an outlet on a circuit different from that to which the receiver is connected.
- Consult the dealer or an experienced technician for help.

Changes or modifications not expressly approved by the party responsible for compliance could void the user's authority to operate the equipment.

Operation on the 5.15-5.25GHz frequency band is restricted to indoor use only. The FCC requires indoor use for the 5.15-5.25GHz band to reduce the potential for harmful interference to co-channel Mobile Satellite Systems. Therefore, it will only transmit on the 5.25-5.35 GHz, 5.47-5.725 GHz and 5.725 –5.850 GHz band when associated with an access point (AP).

CE Notice (European Union)

This device has been tested and found to conform to the limits set for a Class B product.

- EN 55022 — “Limits and Methods of Measurement of Radio Interference Characteristics of Information Technology Equipment”
- EN 55024 — “Information technology equipment - Immunity characteristics - Limits and methods of measurement”
- EN 61000-3-2 — “Electromagnetic compatibility (EMC) - Part 3: Limits - Section 2”
- EN 61000-3-3 — “Electromagnetic compatibility (EMC) - Part 3: Limits - Section 3”
- EN 60950 — “Safety of Information Technology Equipment”.
- EN 55022 Emissions requirements

RF Exposure Information (SAR)

This device is compliance with SAR for general population /uncontrolled exposure limits in ANSI/IEEE C95.1-1999 and had been tested in accordance with the measurement methods and procedures specified in OET Bulletin 65 Supplement C.

This equipment complies with FCC RF radiation exposure limits set forth for an uncontrolled environment. This device was tested for operations with the device contacted directly to the human body to the back side of the EUT. To maintain compliance with FCC RF exposure compliance requirements, avoid direct contact to the transmitted antenna during transmitting.

IC Regulations

Le présent appareil est conforme aux CNR d'Industrie Canada applicables aux appareils radio exempts de licence. L'exploitation est autorisée aux deux conditions suivantes:

- (1) l'appareil ne doit pas produire de brouillage, et
- (2) l'utilisateur de l'appareil doit accepter tout brouillage radioélectrique subi, même si le brouillage est susceptible d'en compromettre le fonctionnement.”

This device complies with Industry Canada license-exempt RSS standard(s). Operation is subject to the following two conditions:

- (1) This device may not cause interference, and
- (2) This device must accept any interference, including interference that may cause undesired operation of the Device.

This Class B digital apparatus complies with Canadian ICES-003

Cet appareil numérique de la classe B est conforme à la norme NMB-003 du Canada.

The device could automatically discontinue transmission in case of absence of information to transmit, or operational failure. Note that this is not intended to prohibit transmission of control or signaling information or the use of repetitive codes where required by the technology.

The device for the band 5150-5250 MHz is only for indoor usage to reduce potential for harmful interference to co-channel mobile satellite systems; the maximum antenna gain permitted (for devices in the bands 5250-5350 MHz and 5470-5725 MHz) to comply with the e.i.r.p. limit; and The maximum antenna gain permitted (for devices in the band 5725-5850 MHz) to comply with the e.i.r.p. limits specified for point-to-point and non-point-to-point operation as appropriate, as stated in section A9.2(3). In addition, High-power radars are allocated as primary users (meaning they have priority) of the band 5250-5350 MHz and this radar could cause interference and/or damage to LE-LAN devices.

The County Code Selection feature is disabled for products marketed in the US/Canada. For product available in the USA/ Canada markets, only channel 1~11 can be operated. Selection of other channels is not possible.

IC Radiation Exposure Statement

This EUT is compliance with SAR for general population/uncontrolled exposure limits in IC RSS-102 and had been tested in accordance with the measurement methods and procedures specified in IEEE 1528.

Read Me First

Follow and adhere to all warnings and instructions in this manual. For your safety, please read all safety and operating instructions before using the product. Keep this manual for future reference.



Attention: Pour réduire le risque d'incendie ou de choc électrique ne pas exposer l'appareil à la pluie ou à l'humidité. VERIFIER que le cordon électrique est la prise murale pour un delai d'inactivite prolongé. Pour arrêter complètement l'alimentation de l'appareil, débranchez le cordon d'alimentation de la prise AC. N'enlever ni le capot arrière ni les pièces internes de l'appareil. Contactez un personnel qualifié si nécessaire.



SA1965

Avertissement Electronique

Utilisé pour les instructions destinés à alerter l'utilisateur d'un CHOC ÉLECTRIQUE mortel ou de blessure grave en cas d'utilisation incorrecte de l'unité.



SA1966

Avertissement Utilisé pour les instructions destinés à alerter l'utilisateur d'un risque mortel ou de blessure grave en cas d'utilisation incorrecte de l'unité.



Attention: Pour réduire le risque d'incendie ou de choc électrique ne pas exposer l'appareil à la pluie ou à l'humidité FAIRE le cordon électrique est DÉBRANCHÉ DE LA PRISE MURALE DANS UN DELAI DE PROLONGER INACTIVITÉ. De se désengager totalement LE POUVOIR DE L'UNITE, S'IL VOUS PLAÎT DEBRANCHER LE CORDON D'ALIMENTATION DE LA PRISE AC. NE PAS Remove le capot arrière, pas de PIÈCES À L'INTÉRIEUR. Contactez un personnel qualifié S'il faut le réparer.



SA1965

Avertissement Electronique

Sert aux instructions destin es alerter l'utilisateur d'un CHOC ÉLECTRIQUE mortel ou de blessure grave en cas d'utilisation incorrecte de l'unit.



SA1966

Avertissement Sert aux instructions destin es alerter l'utilisateur d'un risque mortel ou de blessure grave en cas d'utilisation incorrecte de l'unit .

Informations de sécurité (FR)

Suivez et respectez tous les avertissements et instructions figurant sur l'écran. Pour votre sécurité, s'il vous plaît lire toutes les consignes de sécurité et de fonctionnement avant d'utiliser le device. Gardez ce manuel pour référence future.

1. Lire avec attention toutes les recommandations et précautions d'emploi avant d'utiliser ce produit.
2. Veuillez conserver ces recommandations et précautions pour référence future.
3. Lire et comprendre tous les avertissements énumérés dans les précautions d'emploi.
4. Suivre toutes les précautions d'emploi pour utiliser ce produit.
5. Utiliser exclusivement un chiffon sec pour nettoyer ce produit.
6. Ne pas placer le produit près de toute source de chaleur telle que radiateurs, arrivées d'air chaud, fourneaux ou autres appareils générant de la chaleur (incluant les amplificateurs producteurs de chaleur) .
7. Ne pas négliger la sécurité que procure un branchement polarisé ou avec raccordement à la terre, Un branchement polarisé comprend deux fiches dont l'une est plus large que l'autre. Un branchement à la terre comprend deux fiches plus une troisième reliée à la terre. Si la fiche secteur fournie ne s'insère pas dans votre prise de courant. consulter un 'électricien afin de remplacer votre prise obsolète.
8. Protéger le cordon d'alimentation de tout écrasement ou pincement, particulièrement au niveau des fiches, des réceptacles utilisés et à l'endroit de sortie de l'appareil. Ne pas casser la fiche de terre du cordon d'alimentation.
9. Utiliser uniquement les accessoires spécifiés par le constructeur.
10. Utilisez seulement des accessoires spécifiés par le fabricant ou vendus avec le produit.
11. Débrancher cet appareil lors d'orages ou s'il n'est pas utilisé pendant une longue période.
12. Faire exécuter le service par du personnel qualifié. Une intervention technique est requise lorsque l'appareil a été endommagé ou n'opère pas normalement.



Safety Information (EN)

Follow and adhere to all warnings and instructions on the screen. For your safety, please read all safety and operating instructions before using the device. Keep this manual for future reference.

1. Carefully read all recommendations and precautions for use before using this product.
2. Retain all recommendations and precautions for future reference as necessary.
3. Read and be sure to understand all warnings listed in the precautions.
4. Follow all operating precautions when using this product.
5. Use only a dry cloth to clean this product.
6. Do not place the product near any heat sources such as radiators, warm air intakes, stoves or other heat- generating devices (including amplifiers or other heat producing equipment).
7. Do not disregard the safety that a polarized or grounded connection can provide. A polarized connection consists of two plugs, one of which is larger than the other. A grounded connection has two blades and a third one that is grounded. If the main plug provided cannot be inserted into your outlet, consult an electrician to replace your obsolete outlet.
8. Protect the power cord from being crushed or pinched, particularly in the area of the plugs, any receptacles used, and the point of exit from the apparatus. Do not break off the ground pin of the power cord.
9. Use only accessories specified by the manufacturer.
10. Use only with accessories specified by the manufacturer or sold with the product.
11. Unplug this apparatus during lightning storms or when it is not being used for long periods.
12. Refer all servicing to qualified service personnel. A technical intervention is required when the apparatus has been damaged in any way or does not operate normally.



About the Adapter

- Use only the supplied AC adapter (Rating: Input DC 9-36V DC). Use of another type of AC adapter will result in malfunction and/or danger.
- Do not use the adapter in a high moisture environment. Never touch the adapter when your hands or feet are wet.
- Allow adequate ventilation around the adapter when using it to operate the device or charge the battery. Do not cover the AC adapter with paper or other objects that will reduce cooling. Do not use the AC adapter while it is inside a carrying case.
- Connect the adapter to a proper power source. The voltage requirements are found on the product case and/or packaging.
- Do not use the adapter if the cord becomes damaged.
- Do not attempt to service the unit. There are no serviceable parts inside. Replace the unit if it is damaged or exposed to excess moisture.

Li-Ion Battery

Your device has UPS battery. The UPS battery is only expect to use for backup under system low loading and without I/O function. When disposing UPS battery, follow local rules and regulations.



Warning! Do not dispose the battery with general waste materials.

Avertissement! Ne jetez pas la batterie avec les déchets ordinaires.

The following precautions on battery recycling should be observed:

- The battery should be disposed properly according to local regulations;
- The battery should not be damaged or crushed;
- The battery should not be heated or exposed to direct sunlight.

If you are not aware of local regulations on disposing the battery pack, contact our Service Center or sales representatives for more information.



Important:

This hot-swap battery is soft-packed. It may have up to 8% inflation in dimensions under the usage in normal conditions. The mechanical design of the device reserves the space for this normal inflation.



Warning! If you observe the internal hot-swap battery has been inflated more than normal condition (or the blotch of panel and touch caused by inflated battery), contact our Service Center or sales representative for replacing the battery immediately.

Avertissement! Si vous constatez que la batterie interne remplaçable à chaud a été gonflée plus que dans des conditions normales (ou la tache du panneau et le toucher causés par une batterie gonflée), contactez notre centre de service ou notre représentant commercial pour remplacer la batterie immédiatement.



Important:

The battery is consumable part. Therefore, it is recommended to replace the battery pack every two years with a new one recommended by Winmate. Contact our Service Center or sales representatives for more information on replacing the battery pack.

General Guideline

It is recommended to reboot the device when some functions are defect or inactive. If it still can't solve the problems, please contact your dealer or agent.

1. Unpacking

1.1 Standard Package Content

Before using this device, make sure that all the items listed below are included in your package:



**Computer
FM12Q-V**

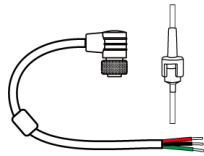

**Power Cable with
Fuse**

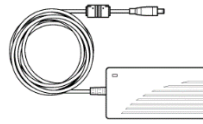

**84W Adapter
with Power
Cable**



**Quick Start
Guide**



**Power Converter
Cable**

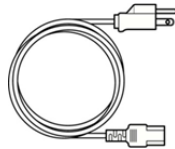

Power Cord

1.2 Optional Accessories

Your package may include the following items based on your order:

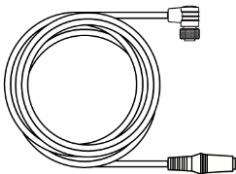

**DC Jack Power
Cable**

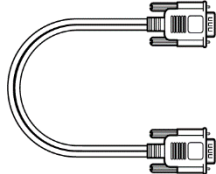

RS232 Cable

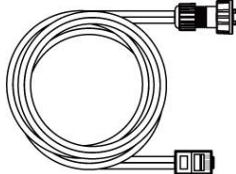

LAN Cable

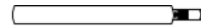

**WWAN
Antenna**



Fuse Kit

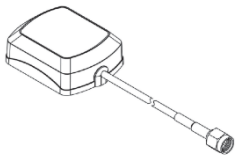

GPS Antenna

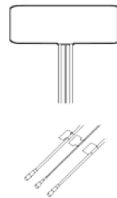

**GPS & LTE
(VM240)**

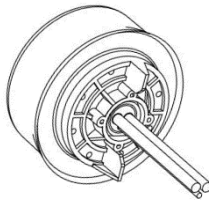

**GPS & LTE
(VM9C)**

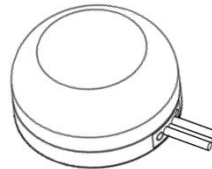

**GPS & LTE
(VM10S)**

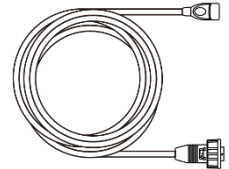

**USB Type A
Cable**

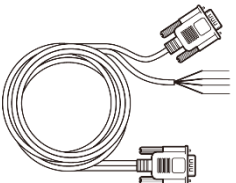

**Comport +
Canbus**

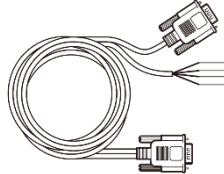

**Comport +
DIDO**

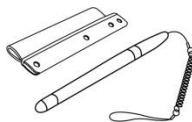



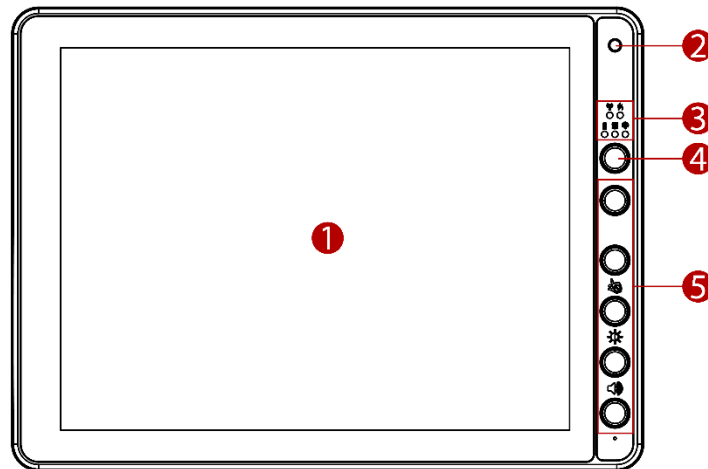

Stylus Kit

2. Components

Front View



No	Item	Description
1	12.1" Touch Screen	Acts as one of the inputs for the device
2	Camera and Microphone	2 Megapixel front camera with a microphone for voice communication and voice recording
3	Light Sensor and LED indicators	 Wireless communication indicators
		 Defroster indicator <i>(Defroster is a customized feature available by request)</i>
		 UPS battery indicators
		 HDD indicators
		 Light sensor
4	Power Button and Indicator	Press and hold the button for 3 second to turn on the device
5	Function buttons	Programmable function keys that can be configured by using the Win-Set® Utility
	Digital Microphone	For voice communication and voice recording

Rear View with Vehicle Dock

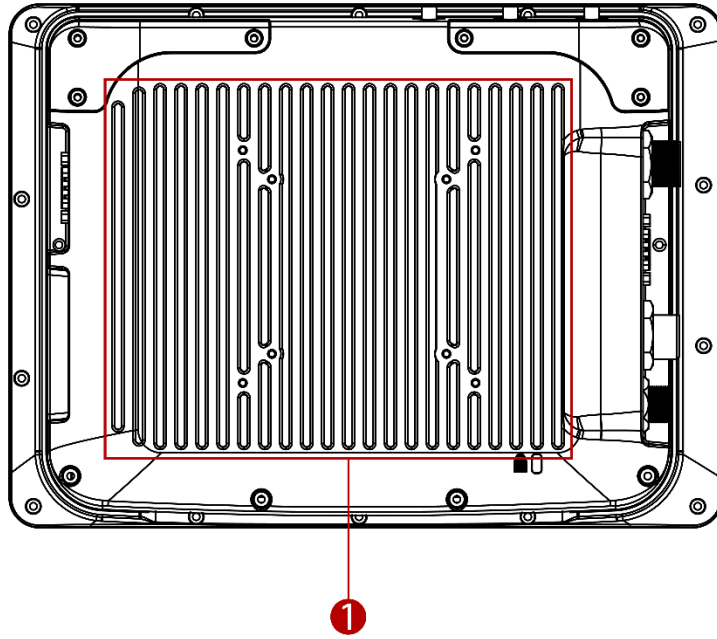

No	Item	Description
1	VESA Mount Hole	VESA 75, 100, and RAM Mount

Top and Bottom View

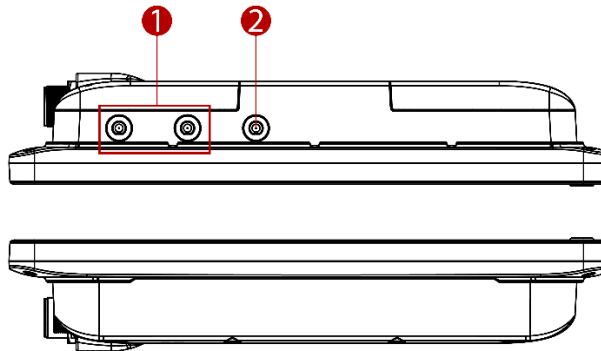

No	Item	Description
1	WWAN Antenna Connector (Optional)	Connect a WWAN external antenna and allow the device to be remotely mounted on the vehicle.
2	GPS Antenna Connector (Optional)	Connect a GPS external antenna and allow the device to be remotely mounted on the vehicle.

Side View with Vehicle Dock

Left Side

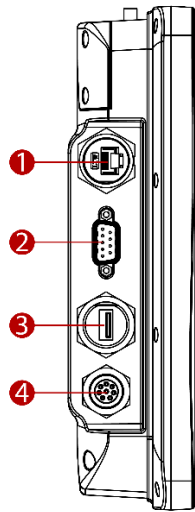

Right Side

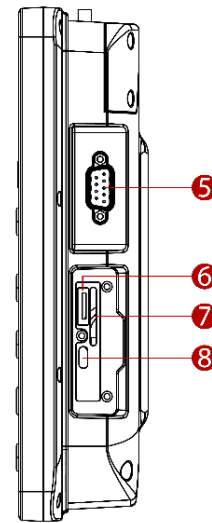

No	Item	Description
1	LAN Port	Connect to a local area network (LAN) using an Ethernet cable.
2	D-SUB A: DB9 male with COM1	Connect a peripheral device such as a printer or scanner with serial port.
	D-SUB A: DB15 male with COM1+DIDO(Optional)	DIDO connector allows direct linking into vehicle, enable access to wide range of vehicle data
3	USB Type-A	Connect USB peripheral devices such as USB Flash drive, mouse, keyboard, printer, etc.
4	Wide Range Power Input	Connect a 9-36V DC IN wide range power input
5	D-SUB B: DB9 male with COM2	Connect a peripheral device such as a printer or scanner with serial port.
	D-SUB B: DB15 female with COM2+CANBus (Optional)	CANBus connector allows direct linking into vehicle, enable access to wide range of vehicle data
6	SD Card Slot	Service window to insert MicroSD card.
7	Dual Nano SIM Card Slot*	Service window to insert Nano SIM cards.
8	USB Type-C	A high-speed USB port connects to USB devices.

Note:

* Only Sierra Module can support dual SIM single standby function.

**For the defroster function please connect a device to a power supply.

3. Integrated Keypad

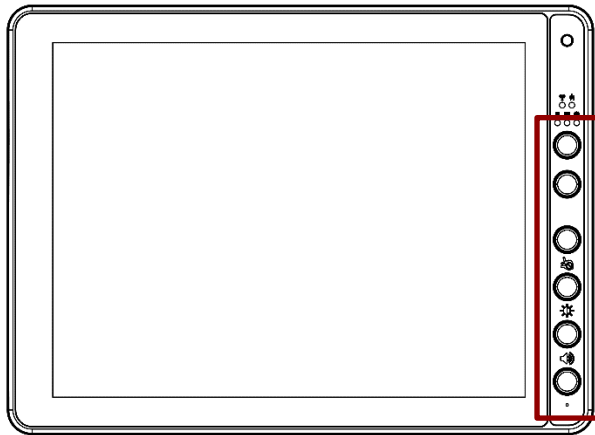

The integrated keypad contains ten programmable keys, F1~ F8 are user programmable keys. Key Mapping is configured via the Hot Tab application on the control panel. See Programmable key to remap these keys.

The default values for these keys are:

Press these keys in this order	Default Key Value
F1+F2	Touch Keypad Lock/Unlock
F2+F3	Brightness adjustment (panel+keypad)
F3+F4	Volume adjustment for Bluetooth devices
Long press on F1	Open WinSet
Long press on F4	Camera
Press on Fn	Function key form F5~F8

Note: Sign plus “+” means that you have to press both function keys at the same time.

4. Function Buttons

Winmate® FM12Q-V Vehicle Mounted Computer comes with preinstalled APP called Winset which let users to assign functions of function keys F1 ~ F8.

To set function keys open **Winset** ,

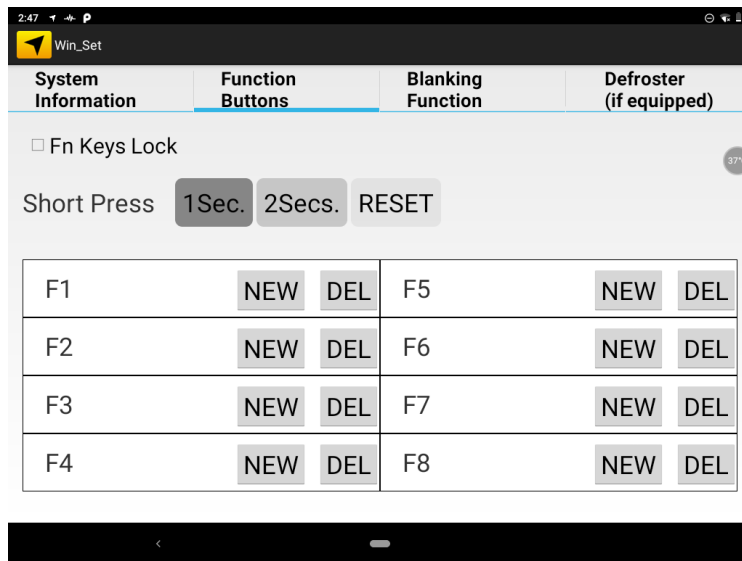

In **Function Buttons** window of the **F1** click **NEW** to open the drop-down menu of function keys. In this example, we have selected to set up functions for **F1** function key.

Choose the function key and then select a **Default application** that will be opened by pressing on the function key you've selected. Press **DEL** to reset the function key to previous settings.

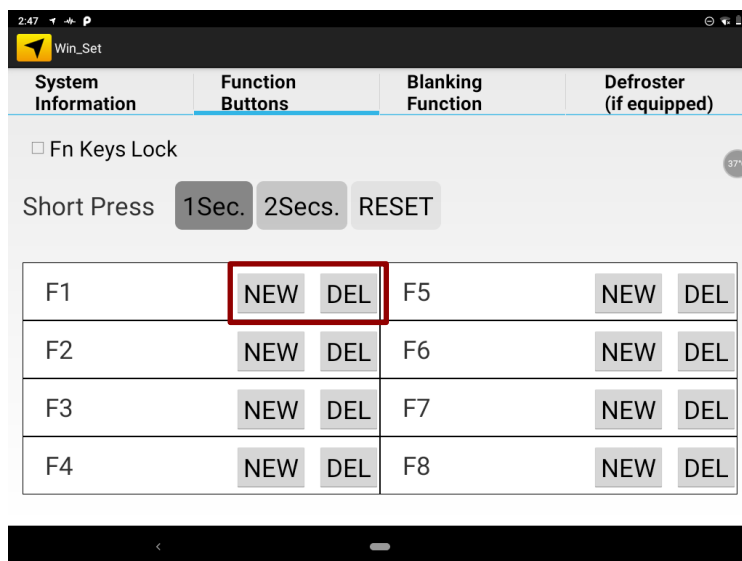

Tick the **Fn Keys Lock** option to disable the function key.

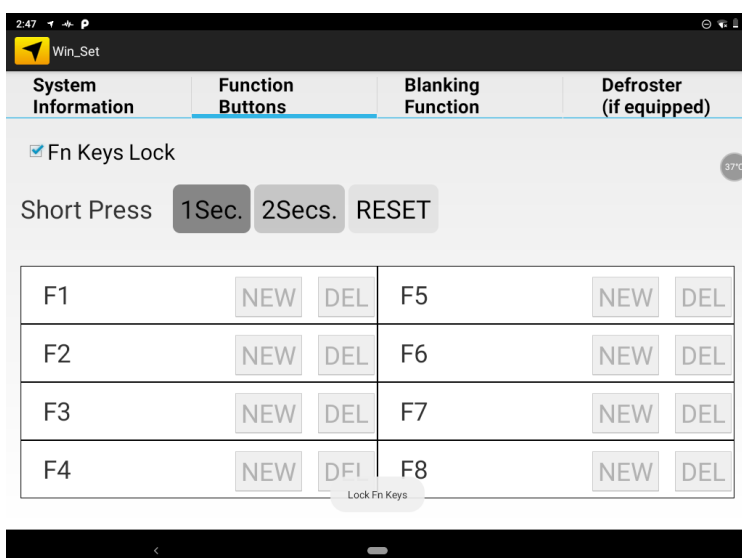

5. Power Cable Installation

5.1 Wiring the Power Cable



Warning! This procedure requires a trained service personnel only, improper installation can cause serious damage to the vehicle or the device.

Avertissement! Cette procédure nécessite un personnel de maintenance qualifié uniquement, une mauvaise installation peut causer des dommages importants au véhicule ou le dispositif.

5.2 Connecting the Power Cable for Testing



Important:

It is highly recommended to purchase the power cable for testing purpose.

Wiring Instruction

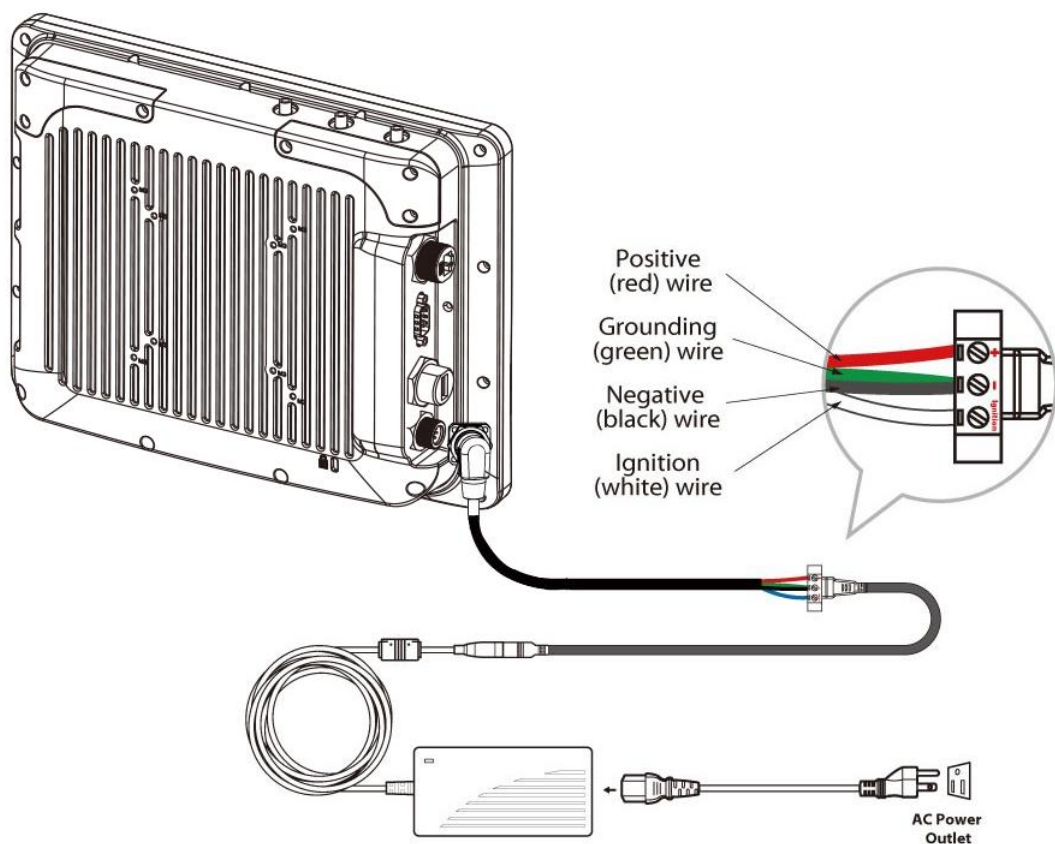

1. Make sure the device is Off.
2. Connect the power cable to the FM12Q-V by aligning the connector pins and then push it, twist to fasten the connection.
3. Connect the AC plug to the electrical outlet.
4. Press the On button, the device is ready for testing.

5.3 Connecting the Power for Installation on the Vehicle



Warning! This power cable should only be used on the 24, 36, or 48 Volt forklifts. Note that, this power cable cannot work for 12 Volt forklifts.

Avertissement! Ce câble d'alimentation ne doit être utilisé sur les 24, 36, ou 48 chariots élévateurs Volt. Notez que, ce câble d'alimentation ne peut pas travailler pour 12 chariots élévateurs Volt.



Warning! Select a mounting location and make sure it is not located on the outside the vehicle.

Avertissement! Sélectionnez un emplacement de montage et assurez-vous qu'il ne se trouve pas à l'extérieur du véhicule.



Warning! Do not perform the installation on a moving or live electric forklift.

Avertissement! Ne pas effectuer l'installation sur un mobile ou un chariot élévateur électrique sous tension.

Wiring Instruction

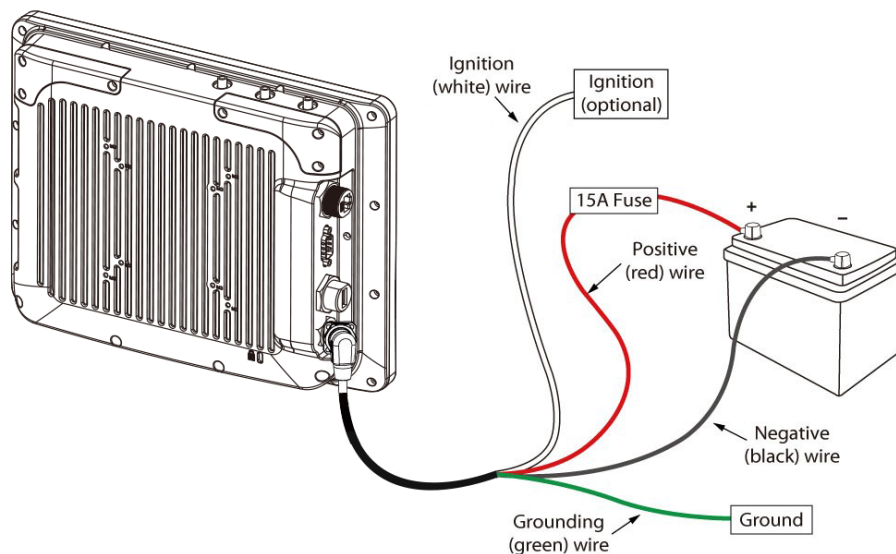

1. Remove the vehicle battery before connecting the power cable
2. Connect the **Green** Wire (Ground) to the vehicle's chassis (grounding), which can also be negative pole of the battery
3. Place the fuse and fuse holder in-line of the **Red** (VCC +) and White (ignition) wires as shown below.

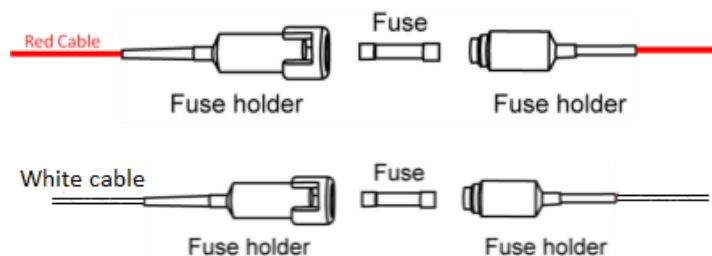

Fuse Specification :

Two Fuses , 15A, 250Volt, UDA Type Fuses

4. Slide tubing over wires, remove the wires and insert it to the fuse holder, crimp it.
5. Connect the **red** wire to the vehicle's positive power source. Connect the black wire to the vehicle's negative power source.

- Connect the white wire to the vehicle's ignition switch for the ignition function, if the requirement is connected to vehicle without ignition, please connect ignition pin to battery V+.



Warning! When power is on, ignition pin connects to battery V+ will cause the power consumption even ignition is off.

Avertissement! Lorsque l'alimentation est allumée, la broche d'allumage se connecte à la batterie V + provoquera la consommation d'énergie même si l'allumage est coupé

Power cable description:00000

Color	Symbol
Red	VCC+
Black	VCC-
Green	Ground
White	Ignition input (optional)

With Ignition Function

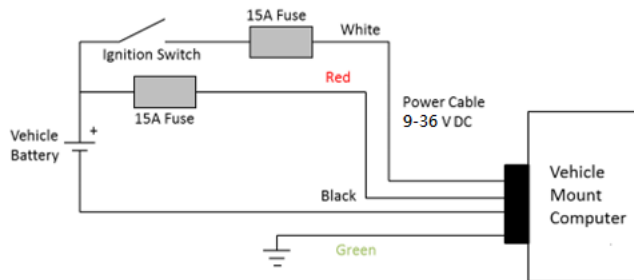

- The ignition cable (White cable) must be connected to the battery positive if the customer does not want to have ignition function, as following.

Without Ignition Function

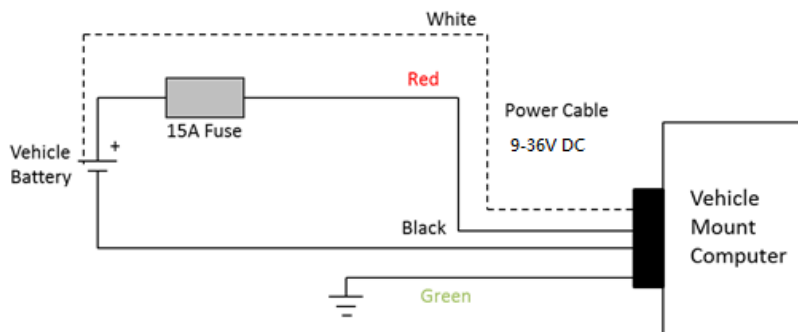

- Press the power button on the front of the device See *Power Button*.

6. Power on Behavior

The table below shows the Ignition control power scheme on the vehicle installation and office test.

Power On Behavior	Office Test / Evaluation	Vehicle Installation	
		With Ignition	Without Ignition
Ignition delay	Default '0" sec"	Default ""0 sec"	Default ""0 sec"
	Adjustable from 0-120 sec, through application. Refer to Ignition Control application.		
Auto-ON	OFF	ON	ON
Power Button	√	X	X

6.1 Power Control

6.1.1 Power Button

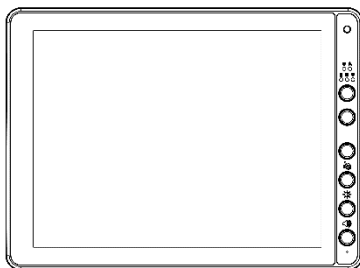

Power button is located at the right side of the FM12Q-V. If the device is OFF, pressing the power button will start the power up sequence.







Note:

- If no external power available and the UPS battery do not have enough charge, pressing the power button will cause no action.

6.2 Standby and Wakeup Behavior

The FM12Q-V has four power modes: Turn On, Suspend, Wake up, and Turn Off.

Action	Button		LED Indicator
Turn On		Press the On button for "3 seconds" until the blanking indicator located on the right side On (solid red), and then release the button.	 On
Suspend		Press the On button for "1 seconds" until the screen On and then release the button. The battery indicator will Off after the screen is Off, the system is already in the standby / sleep mode.	Off
Wake Up		Press the On button for "1 second" until the screen On and then release the button.	Off

Turn Off		Press the On button for “2 second” until the system is turns Off and then releases the button.	Off
----------	---	--	-----

6.2.1 Turn On

When the FM12Q-V is attached to an external power supply, the power button is pressed, the device is in the “ON” mode. In this mode, the keypad, touch screen and any attached peripherals will function normally. The display remains ON until the display, standby or suspend timer expires. When the device is in ON mode, the power LED indicators is off.

6.2.2 Suspend

When the device is in Suspend Mode, all LEDs are off. Press the power button to wake up the device back to ON mode.

6.2.3 Wake Up

When the device is in Wake-Up Mode, all LEDs are off.

6.2.4 Turn Off

By default, the FM12Q-V turns off if the user turns off the device through the system or presses the power button for 10 seconds with a critical shut down. The FM12Q-V will also be off when there is no connection to a power source or the UPS battery is depleted. However, the internal RTC will keep maintaining the date and time while the device is off.

7. Ignition Control

Winmate provides Ignition Control feature in Winset  application to control the timing of delay. You can select 1 to 120 seconds for each period of timing delay.



Note:

If you don't plan to use the ignition feature connect the green wire to the vehicle's positive power source.

Go to APPS > Winset  > Ignition Control

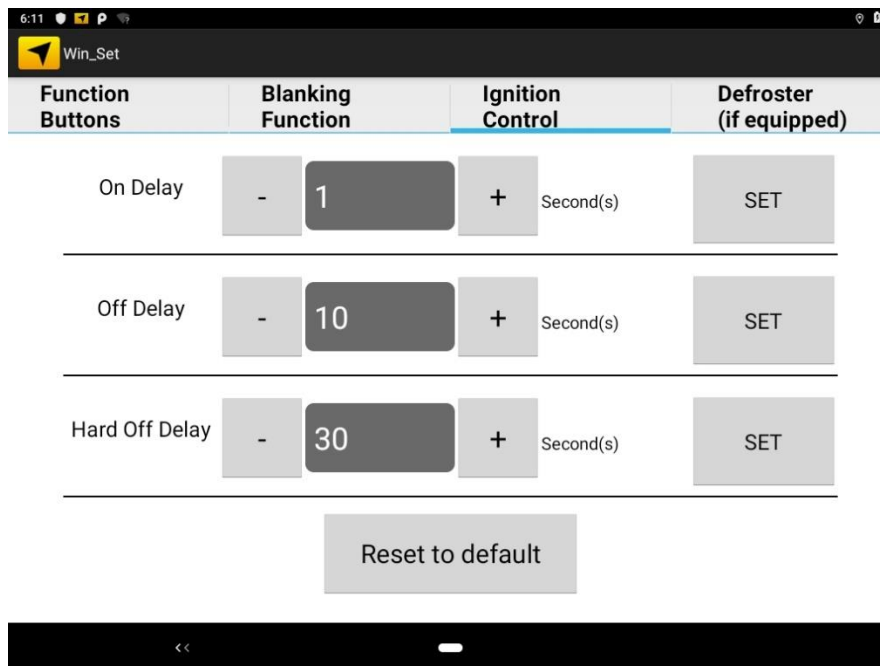

Setting	Default Setting	Description
On Delay	1 second	When the system is powered on via ignition key, the system will delay 1 second to power on.
Off Delay	10 seconds	When the system is powered off via ignition key, the system will delay 10 seconds to shut down.
Hard Off Delay	30 seconds	When the system is powered off via ignition key, the device will cut off power after 30 seconds.
Reset to default	-	Resets the ignition settings back to the default.

8. External/ Vehicle Remote Antenna Installation

The FM12Q-V is equipped with SMA Connector for additional external antenna (Optional GPS or WWAN), to install the antenna please perform the following:

1. Remove the rubber cap on the SMA connector before installing the antenna.
2. Align the antenna with the SMA connector and fasten it as following picture.

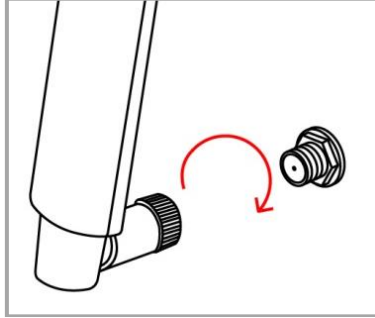

3. Adjust the position of external antennas.

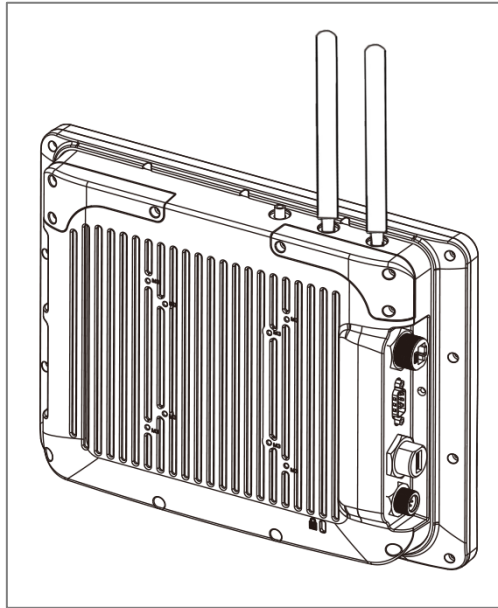

WWAN Antenna Installation

9. Screen Blanking

Winmate® FM12Q-V has screen blanking function. Once activated, it will lock the screen display to prevent or restrict the use of the in-vehicle computer. This application allows setting the threshold to perform preset actions while device is moving. When enabled Blanking function reduces visual, cognitive, and physical distractions by limiting device functionality while the vehicle is in motion.

To set up threshold actions

Go to **APPS > Winset**  **> Blanking Function**

Step 1 Choose both of these conditions or either one to set up the threshold.

Step 2 Select what action you want to perform while the threshold had been triggered.

Step 3 Press **Set**.

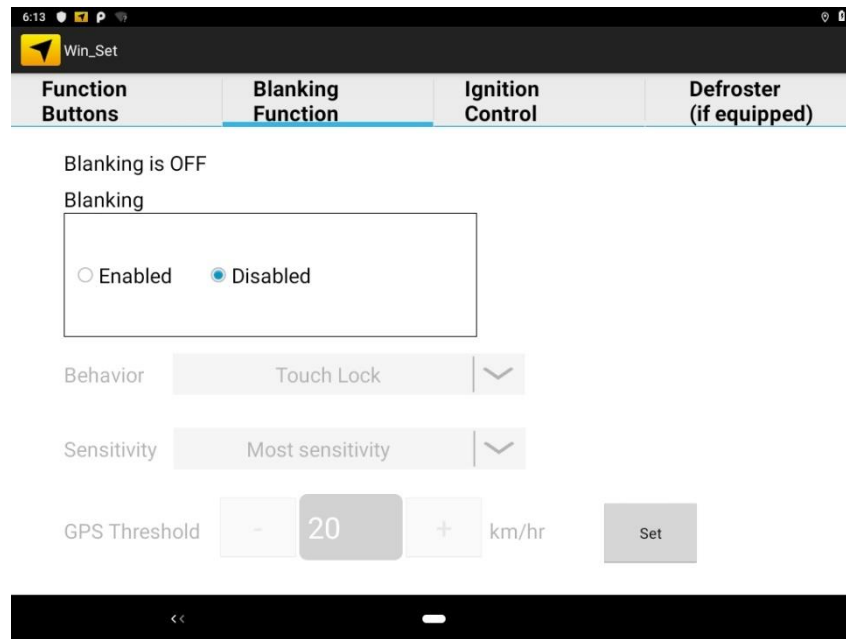

Setting	Setting Options	Description
Blanking ON/ OFF	-	Enable or disable screen blanking function.
Behavior	Touch Lock	Locks touch function.
	Blank Screen	Screen is going blank.
	Lock and Blank Screen	Locks touch function and screen is going blank.
	Show Dialog	Warning “Moving too fast” appears on the screen each time G-Sensor Threshold Level / GPS Threshold level exceeds preset parameters.
Sensitivity	Mode 1	Most sensitivity
	Mode 2	High sensitivity
	Mode 3	Medium sensitivity
	Mode 4	Low sensitivity
GPS Threshold	0 km/ hr ~ 20 km/ hr	When the speed reaches GPS threshold settings, screen blanking function will be activated in 2 seconds

10. Defroster (Optional)

Notice that defroster is an optional feature and may not be presented in your device.



Warning! The defroster is always disabled when the device is operating from UPS battery power.

Avertissement! Le dégivreur est toujours désactivé lorsque l'appareil fonctionne à partir d'une alimentation par batterie UPS.

To use a defroster, please connect a device to power supply.

1. To show the defroster open **Winset** , and this screen below shows the information about the defroster.

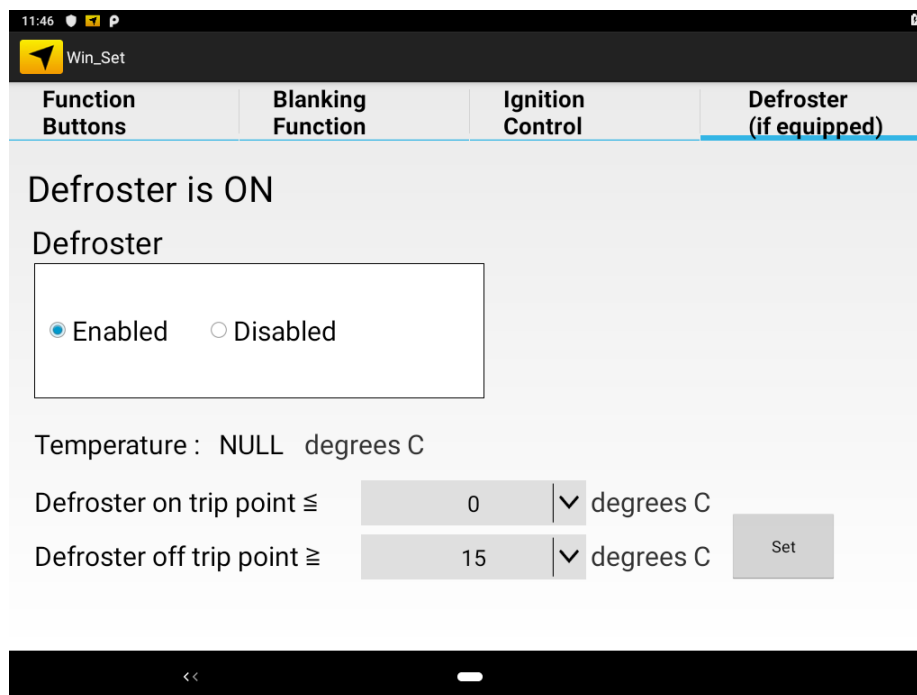

Default Settings:

Function Key	Description
On trip point	0°C
Off trip point	15°C

Note: To complete setting press the Set button every time you change the setting.

2. Depending on the defroster trip point, to trigger the Defroster ON, the defroster on trip point needs to be lower than 0°C. The defroster on trip point is configurable as follow:

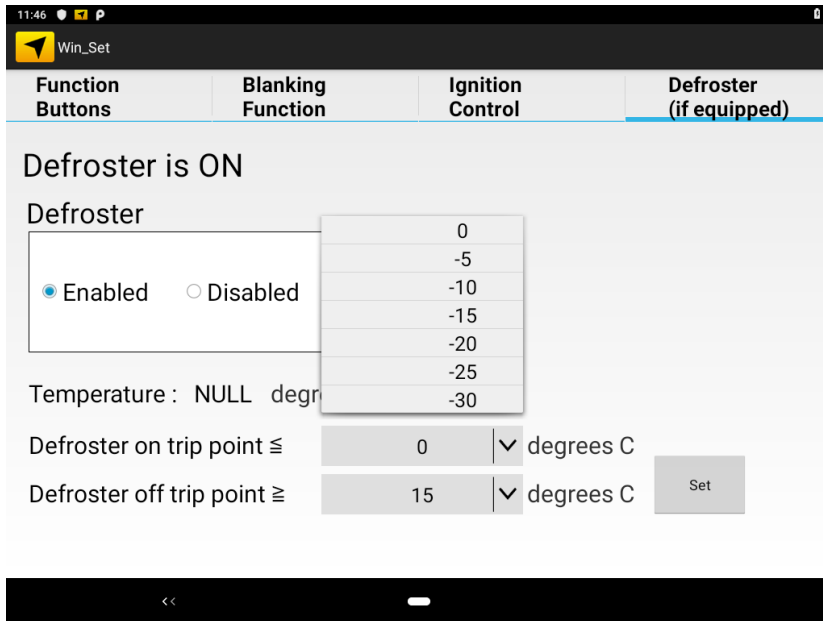

When the Defroster is ON, a defroster indicator in the lower right corner of the device will show Red Color.

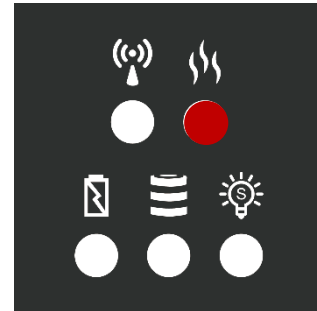

Example: In this example “0° C” is selected as Defroster trip on point meaning that the Defroster will be activated when the temperature drops down to 0°C.

- To trigger the Defroster OFF, the Defroster off trip point needs to be set higher than the set temperature. The defroster off trip point is configurable as follow:

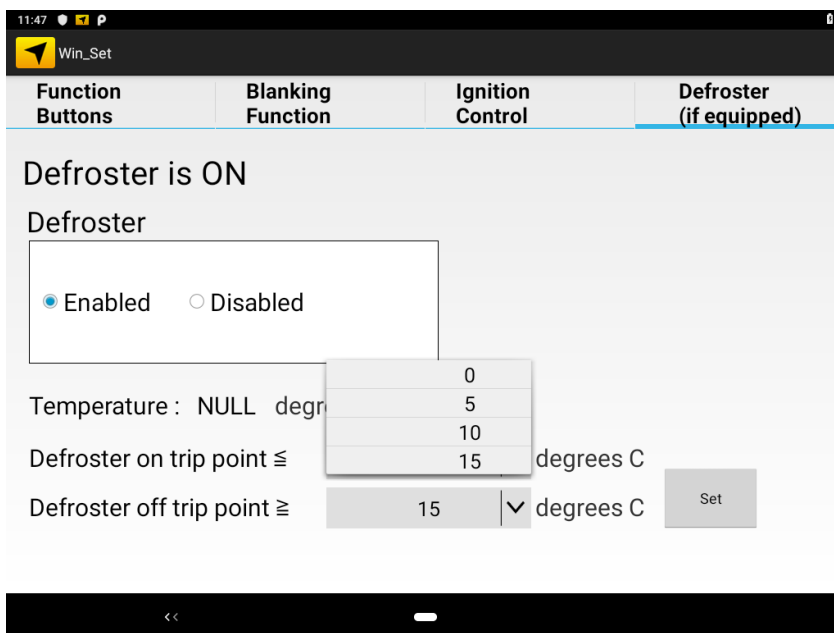

When the Defroster is OFF, a defroster indicator in the lower right corner of the device will Turn off

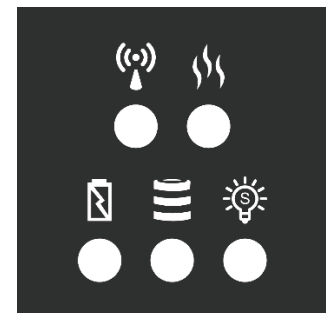

Example: In this example “15°C” is selected as Defroster trip off point meaning that the Defroster will be deactivated when the temperature reaches 15° C.

- To disable or turn off the defroster, tap the disabled button, and then press the set button to complete the setting. This will keep the defroster Off in any condition.

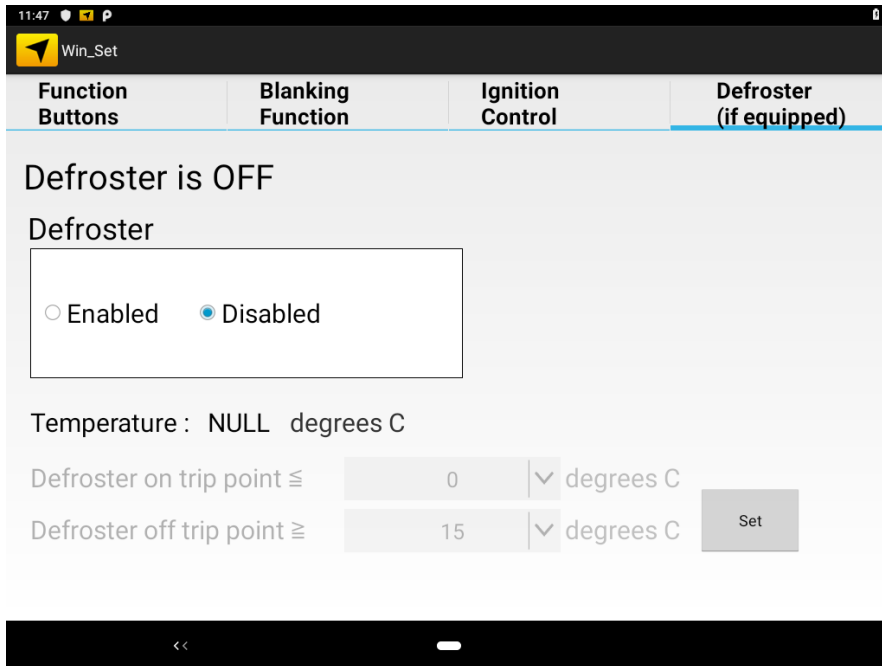

When the Defroster is OFF, a defroster indicator in the lower right corner of the device is Turn off

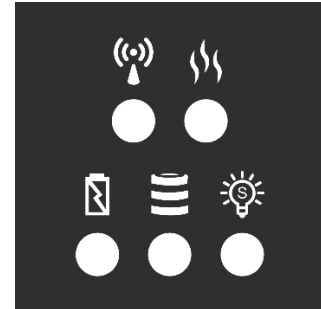

11. RAM Mount Installation

The device is designed to be mounted to RAM Mount solutions, which provides various mount types to fit any industrial use or vehicle. Notice that RAM Mount kits are not standard accessory of Winmate. We recommend ordering RAM Mount accessories from RAM Mount.

11.1 Mounting Kit 1 – No Drill Solution

The device is designed to be mounted to RAM Mount solutions, which provides various types of mount types to fit any industrial use or vehicle. Each mounting kit consists of:

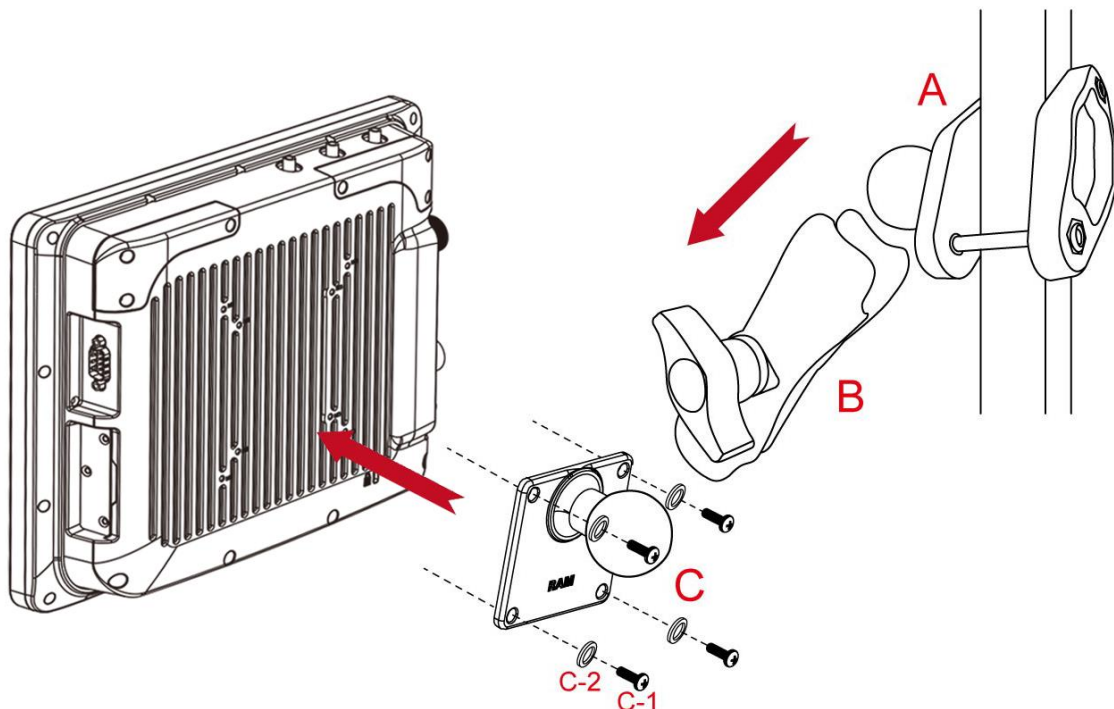

No	Component	RAM Mount Part Number	Description	QTY
A	RAM Clamp Mounts - on the forklift	RAM-D-247U-4	Clamp base with 2.25" Ball	1
B	RAM Arm	RAM-D-201U	Arm for 2.25" Ball(L:8.375")	1
C	RAM Ball on the device side	RAM-D-2461U	75x75mm VESA with 2.25" Ball	1
C-1	Screw	-	SUS304 M5 x 12mm Screw	5
C-2	Washer	-	M5 Washer	5

11.2 Mounting Kit 2 – Drill Solution

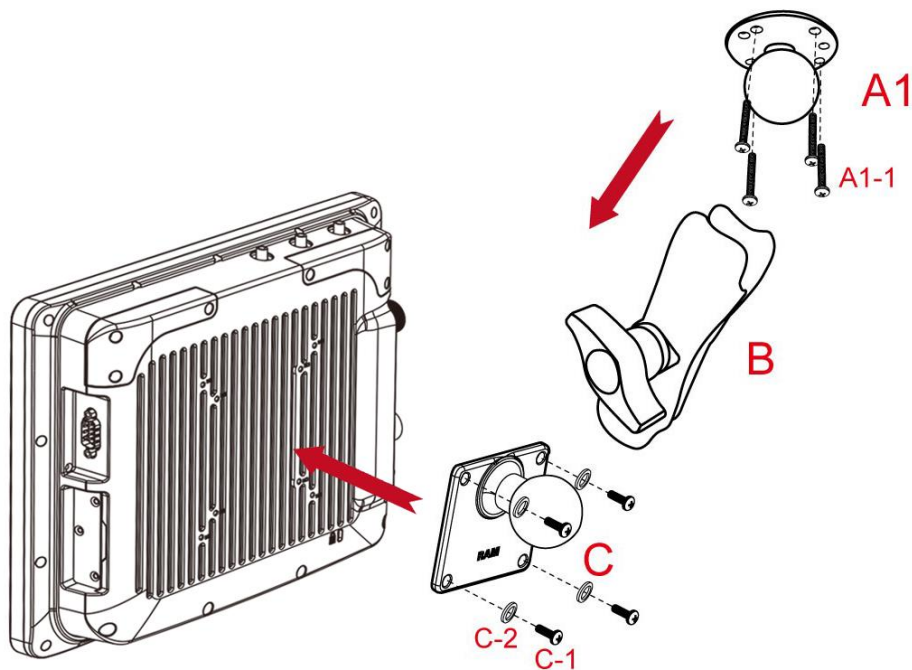

No	Component	RAM Mount Part Number	Description	QTY
A1	RAM round base mounts - on the forklift	RAM-D-202U	3.68" Round Base with 2.25" Ball	1
A1-1	Screw	-	SUS304 M8 x 40mm Screw	5
B	RAM Arm	RAM-D-201U	Arm for 2.25" Ball (Length:8.375")	1
C	RAM Ball on the device side	RAM-D-2461U	75x75mm VESA with 2.25" Ball	1
C-1	Screw	-	SUS304 M5 x 12mm Screw	5
C-2	Washer	-	M5 Washer	5

11.3 RAM Mount Assembly

Step 1 Install RAM Clamp to vehicle or forklift

- Determine the position for mounting the RAM clamp mount according to RAM Mounts installation guide and specification.
- Place the upper clamp with ball on the beam, insert the bolt.
- Place the lower clamp below the beam. Align the bolts with the holes in the lower clamp.
- Place the nuts and then tighten it.

Step 2 Install RAM Ball base to vehicle dashboard / another surface.

- Please make sure that the surface is flat and rigid.
- Attach the RAM ball base to the vehicle and fix it using bolt or fasteners.

Step 3 Attach RAM Mount Ball to the device docking.

- Turn the device off before installing the RAM mount ball.
- Locate the VESA mount holes on the back of the device and align it with the holes from RAM Ball base. Fix with four M5 screws.

Step 4 Attach the device to RAM arm.

- Insert the RAM arm over the ball on the vehicle RAM mount (shown here).
- Insert the ball on the dock into the RAM arm and tighten the knob.

11.4 Mounting Kit 3 – Keyboard Mounting Installation

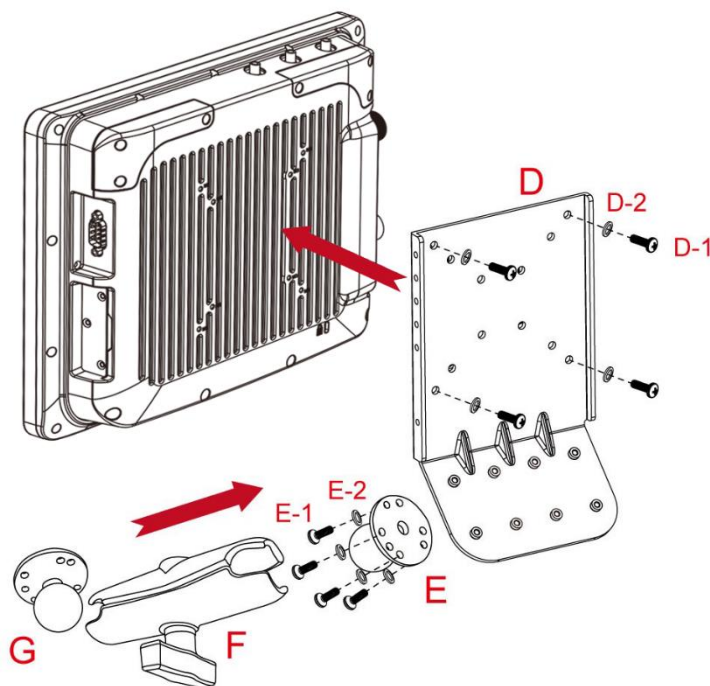

No	Component	RAM Mount Part Number	Description	QTY
D	Winmate Keyboard Adapter Plate (designed by Winmate)	-	4 VESA Holes on the plate to device and 4 AMPS holes to RAM Ball	1
D-1	Screw	-	SUS304 M5 x 20mm Screw	5
D-2	Washer	-	M5 WASHER	5

No	Component	RAM Mount Part Number	Description	QTY
E	RAM Ball on the sloped part of the keyboard adapter plate	RAM-202U	2.5" Round Base with 1.5" Ball	1
E-1	Screw	-	SUS304 M4 x 14mm Screw	5
E-2	Washer	-	M4 WASHER	5
F	RAM Arm	RAM-201U	Arm for 1.5" Ball (Length:5.6")	1
G	RAM Ball on the sloped part of the keyboard adapter plate	RAM-202U	2.5" Round Base with 1.5" Ball	1

11.5 Keyboard Assembly

This part shows the steps to install the keyboard.

1. Fasten all four screws on the RAM mount ball on the back of the keyboard.

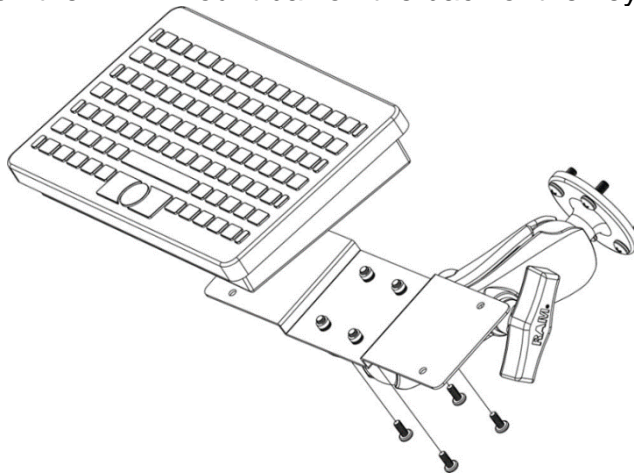

2. Fasten the keyboard adapter on the other end of the RAM mount ball.

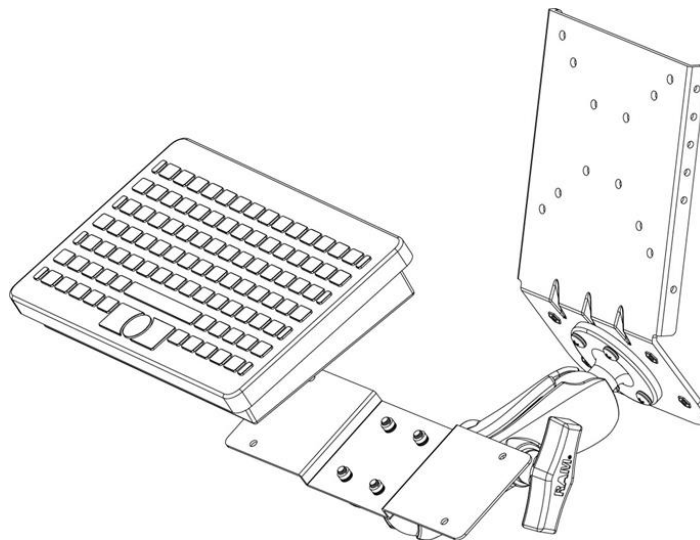

3. Fasten the RAM mount ball screws on the back of the device, so all mounting parts are fastening together.

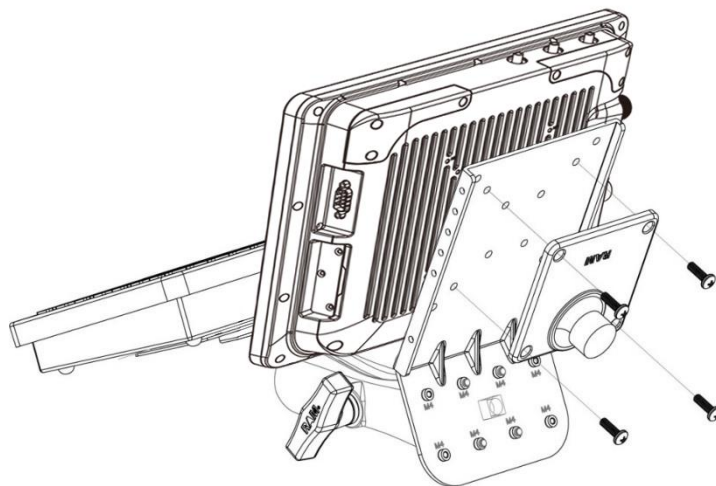

12. Changing Touchscreen Modes

The touch screen of the FM12Q-V Series Rugged Tablet supports hand, stylus, glove and water-resistant modes. You can change the touch mode in Accessibility settings.

Mode	Description
Hand Mode (Default)	<p>In <i>Hand</i> mode, the touchscreen supports inputs from the bare fingertips and rubber tip passive stylus (shipped with tablet). This is a default mode setting.</p> <p><i>Supports input by:</i></p> <ul style="list-style-type: none"> • <i>Rubber tip passive stylus</i> • <i>Bare fingertips</i>
Stylus Mode	<p>In <i>Stylus</i> mode, the touchscreen supports inputs from the fine-tip passive capacitive stylus (shipped with tablet).</p> <p><i>Support input by:</i></p> <ul style="list-style-type: none"> • <i>Fine-tip passive stylus with palm rejection</i> • <i>Rubber tip passive stylus</i> • <i>Bare fingertips</i>
Glove Mode	<p>In <i>Glove</i> mode, the touchscreen supports inputs while the user is operating the touchscreen with gloves on.</p> <p><i>Supports input by:</i></p> <ul style="list-style-type: none"> • <i>Glove</i> • <i>Rubber tip passive stylus</i> • <i>Bare fingertips</i>
Water Resistant Mode	<p>In <i>Water Resistant</i> mode, the touchscreen may reject false inputs from liquid drops. To continue using the touchscreen, please clear any remaining liquid droplets away from the touchscreen and wait 3 seconds before using the touchscreen again.</p> <p><i>Supports input by:</i></p> <ul style="list-style-type: none"> • <i>Rubber tip passive stylus</i> • <i>Bare fingertips</i>

To change touch mode:

1. Open **Settings>Accessibility > Touch Mode**.

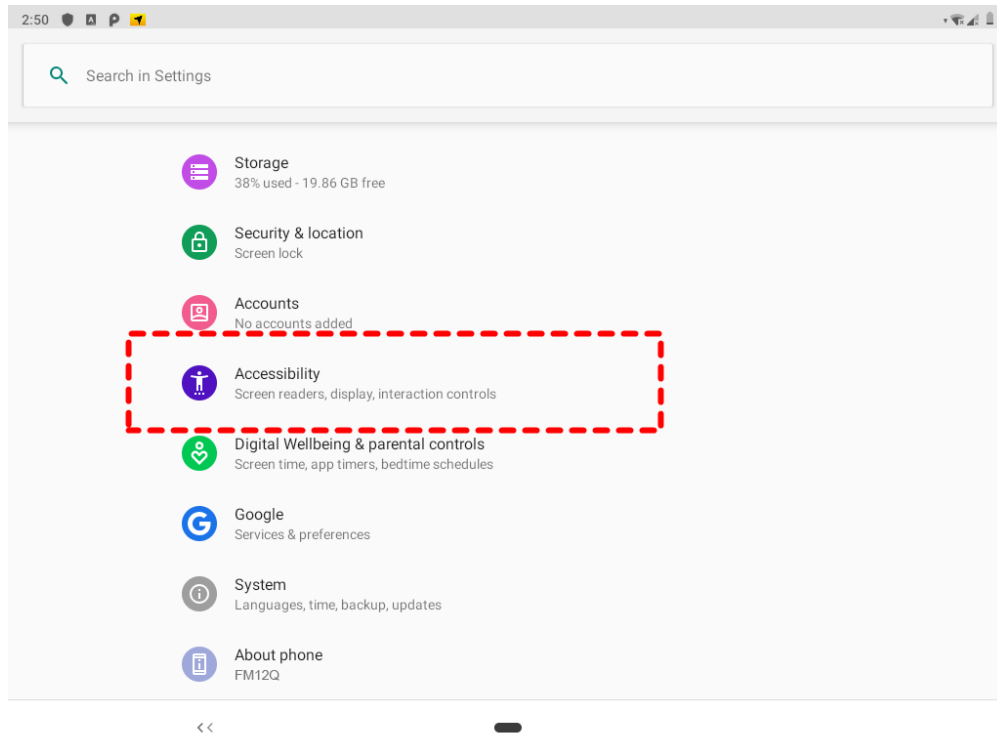

2. Select touch mode. Follow the table below for more information about each touch mode.

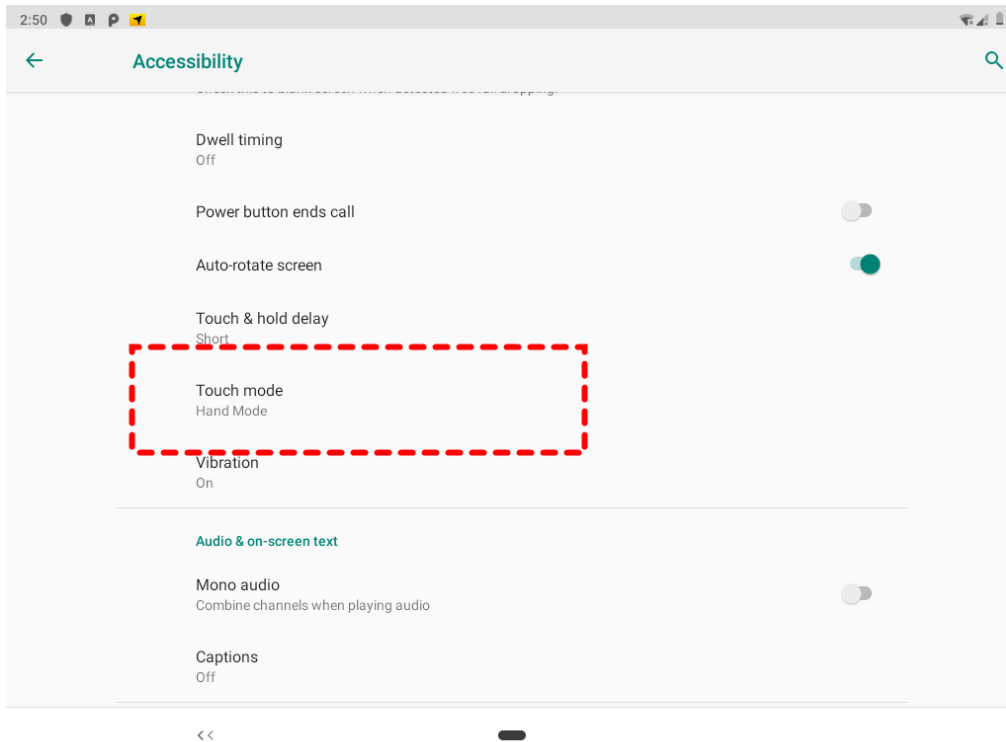

3. Select the touch mode and leave the Touch Mode settings.

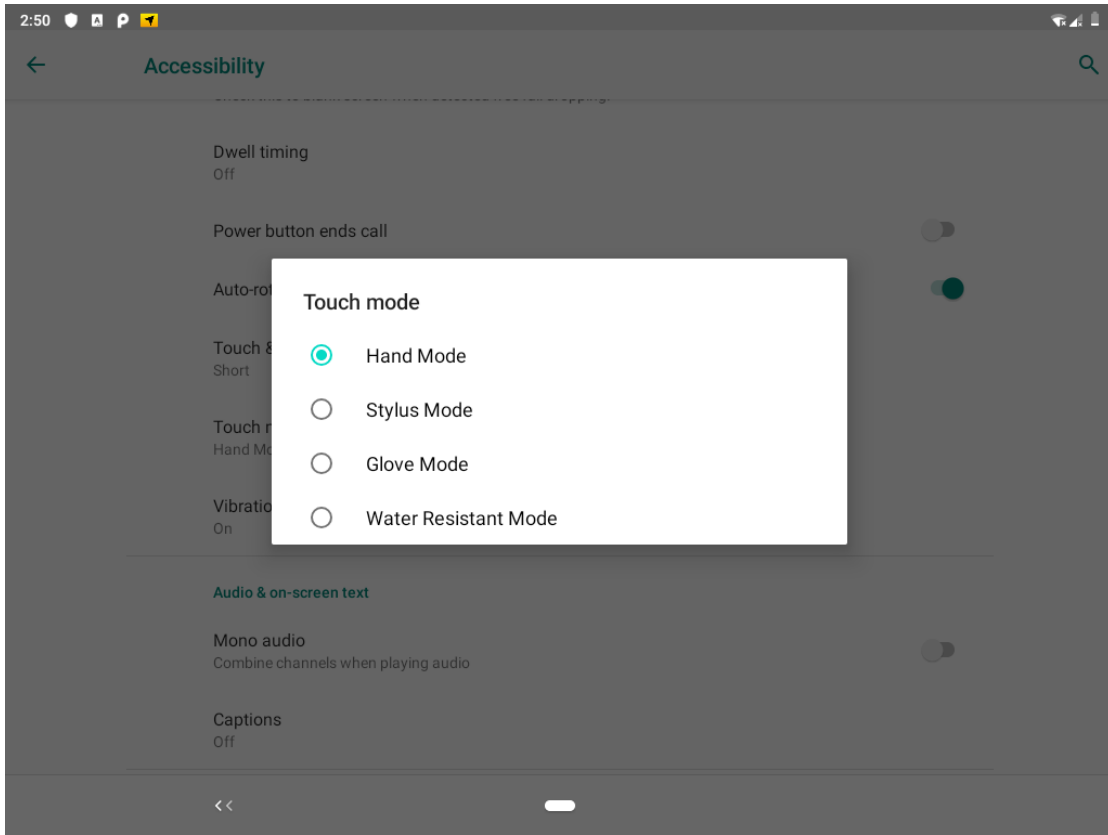

Appendix

Appendix A: Product Specifications

Model Name	FM12Q-V
Display Specifications	
Size / Technology	12.1"
Resolution	1024 x 768
Brightness	400 nits (optional 800 nits)
Touch	PCAP multi-touch, with Hand, Stylus, and Glove support
Contrast Ratio	1000:1
Viewing Angle	89,89,89,89
Sensor	G-Sensor, Temperature Sensor
System Specifications	
Processor	Qualcomm Snapdragon™ 660 octa-core, 2.2 GHz
System Memory	3GB LPDDR4
Storage	32GB eMMC, additional storage with Micro SD card slot
Operating System	Android 9.0
Wireless Communications	
WLAN	Support
BT	Support
GNSS	GPS /GLOMASS(Optional)
WWAN	4G/LTE (Optional)
Interface	
Computer	<ul style="list-style-type: none"> 1 x Dual-Nano SIM Card Slot 1 x Micro SD Card Slot 1 x USB 3.0 Type C (OTG) 1 x USB 2.0 port 1 x 9-36V with ignition control 2 x RS232/422/485(Default RS232) 1 x Gigabit LAN port 1 x DIDI (2xDI; 2xDO) (Optional) 1 x CANBus (Optional)
Input	
Touch	Projected Capacitive Multi Touch
Physical Buttons	1 x Power Button, 5 x function Button (Programable Function Key Configured by Winset)
Status Indicators	
LED Indicators	Wi-Fi, BT, UPS battery, Screen Blanking, Heater <i>*Defroster is a customized feature available by request.</i>
Cameras	
Front Camera	2 MP Camera
Security Function	
Mobile Device Management	SOTI MobiControl compatible
Mechanical	
Dimensions (W x L x H)	307 x 225 x 57 mm (12.08" x 8.85" x 2.24")
Weight	2.5kg
Cooling System	Fanless design
Environment	
Operating Temperature	-30°C to +50°C (-22°F to +122°F)

Model Name	FM12Q-V
Storage Temperature	-30°C to +60°C (-22°F to +140°F)
Humidity	5% to 95% RH, non-condensing
IP Proof	IP65, Compliance IEC60592
Impact	Support EN62262 IK07 rating
Shock	MIL-STD-810H Method 516.8 Procedure I
Vibration	MIL-STD-810H Method 514.8 Procedure I
ESD	Compliant with EN 61000-4-2, enhanced ESD to ±8kV direct & ±15kV air
Power Management	
Tablet Power Input	9-36V DC with ignition
Battery	400mAh UPS Battery for 20 minutes backup (Optional)

NOTE:

1. Accessories and Integrated Options may vary depending on your configuration. The product shown in this document is a standard model. For diagrams that contain customized or optional I/O, please contact the Winmate Sales Team for more information.
2. All specifications are subject to change without prior notice.
3. Only Sierra Module can support dual SIM single standby function.
4. The UPS battery is only expect to use for backup under system low loading and without I/O function.



Winmate Inc.
9F, No.111-6, Shing-De Rd., San-Chung District,
New Taipei City 24158, Taiwan, R.O.C
www.winmate.com

Copyright © 2022 Winmate Inc. All rights reserved.

