

EGPL-21S1

M.2 2280 to Single Isolated 2.5GbE LAN Module

Customer:

Customer

Part Number:

Innodisk

Part Number:

Innodisk

Model Name:

Date:

Innodisk	Customer
Approver	Approver

Table of Contents

- TABLE OF CONTENTS I**
- REVISION HISTORYII**
- LIST OF TABLES 1**
- LIST OF FIGURES 2**
- 1. PRODUCT INTRODUCTION 3**
 - 1.1. OVERVIEW 3
 - 1.2. FEATURES 3
- 2. PRODUCT SPECIFICATIONS 5**
 - 2.1. DEVICE PARAMETERS 5
 - 2.2. ELECTRICAL SPECIFICATIONS 5
 - 2.2.1.POWER REQUIREMENT 5
 - 2.2.2.POWER CONSUMPTION 5
 - 2.3. ENVIRONMENTAL SPECIFICATIONS 5
 - 2.3.1.TEMPERATURE RANGES 5
 - 2.3.2.HUMIDITY 6
 - 2.3.3.SHOCK AND VIBRATION 6
 - 2.3.4.MEAN TIME BETWEEN FAILURE (MTBF) 6
 - 2.4. CE AND FCC COMPATIBILITY 6
 - 2.5. ROHS COMPLIANCE 6
 - 2.6. HARDWARE..... 7
 - 2.6.1.LAYOUT 7
 - 2.6.2.PIN DEFINE 8
 - 2.6.3.I/O CONNECTOR MECHANICAL DRAWING & PIN DEFINES 9
 - 2.6.4.EGPL-21S1 MECHANICAL DRAWING12
 - 2.6.5.CABLE MECHANICAL DRAWING14
 - 2.6.6.PACKING LIST14
 - 2.7. SOFTWARE SUPPORT.....15
- 3. INSTALLATION GUIDE 15**
- 4. APPEDIX 16**
- CONTACT US..... 23**

REVISION HISTORY

Revision	Description	Date
1.0	First Released	June, 2023

List of Tables

TABLE 1: DEVICE PARAMETERS 5

TABLE 2: POWER REQUIREMENT..... 5

TABLE 3: POWER CONSUMPTION 5

TABLE 4: TEMPERATURE RANGES..... 5

TABLE 5: SHOCK AND VIBRATION 6

TABLE 6: MEAN TIME BETWEEN FAILURE (MTBF)..... 6

TABLE 7: M.2 2280 PCB LAYOUT LEGEND..... 7

TABLE 8: DAUGHTER BOARD PCB LAYOUT LEGEND 7

TABLE 9: M.2 B-M KEY PIN DEFINE 8

TABLE 10: WIRE TO BOARD SMD 2*10P CONNECTOR PIN DEFINE..... 9

TABLE 11: RJ45 LAN LED TABLE..... 11

List of Figures

FIGURE 1: BLOCK DIAGRAM 3

FIGURE 2: M.2 2280 BOARD PICTURE..... 4

FIGURE 3: MOUNTING HOLE DAUGHTER BOARD PICTURE (EGPL-21S1-C1/W1) 4

FIGURE 4: BRACKET DAUGHTER BOARD PICTURE (EGPL-21S1-C2/W2)..... 4

FIGURE 5: WIRE TO BOARD SMD 2*10P CONNECTOR DRAWING..... 9

FIGURE 6: RJ45 CONNECTOR DRAWING 10

FIGURE 7: EGPL-21S1 M.2 BOARD DRAWING 12

FIGURE 8: MOUNTING HOLE DAUGHTER BOARD DRAWING (EGPL-21S1-C1/W1) 12

FIGURE 9: BRACKET DAUGHTER BOARD DRAWING (EGPL-21S1-C2/W2) 13

FIGURE 10: BRACKET DRAWING 13

FIGURE 11: BOARD TO BOARD LAN CABLE DRAWING..... 14

1. Product Introduction

1.1. Overview

Innodisk EGPL-21S1 is designed with M.2 2280 form factor with B/M key, EGPL-21S1 supports PCIe Gen 2.1 with a single lane to single isolated 2.5GbE LAN, optimized for higher performance and lower power, which brings you a flexible expansion solution for embedded systems.

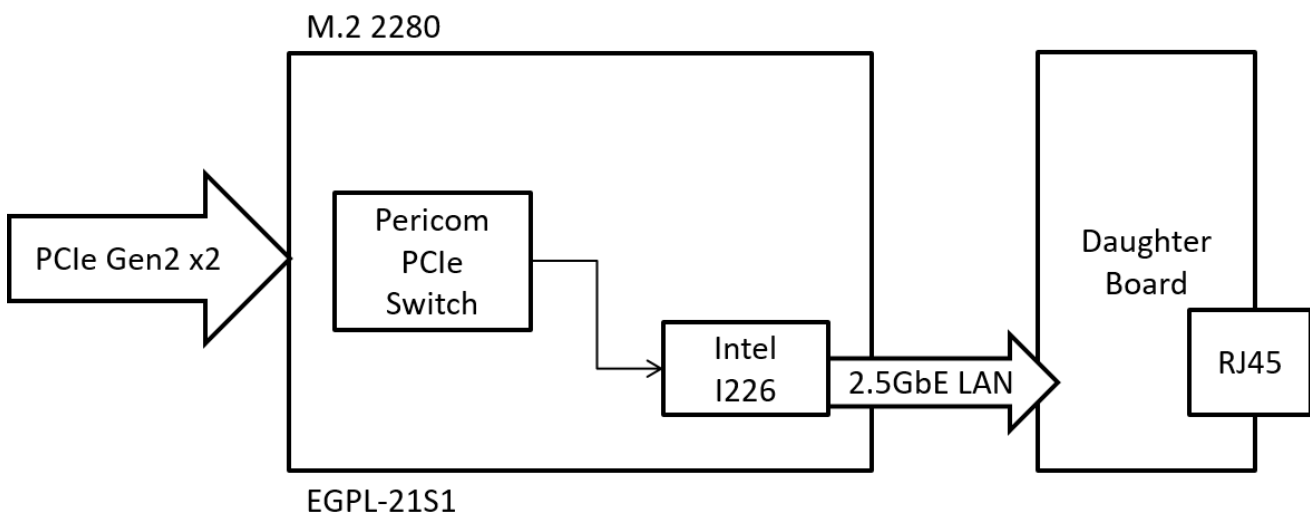

Figure 1: Block Diagram

1.2. Features

- Single isolated 2.5GbE LAN port
- Complies with EN61000-4-5 2kV Surge protection
- Complies with IEC 60950-1:2005 + A1: 2009 + A2:2013 2kV HiPOT protection
- Complies with EN61000-4-2 (ESD) Air-15kV, Contact-8kV
- Flexible daughter board with cable to fit into different system
- Optional terminal mounting hole or bracket for daughter board
- Optional Industrial Temperature (-40°C to +85°C) support
- 30μ " golden finger, 3-year warranty
- Industrial design, manufactured in Innodisk Taiwan

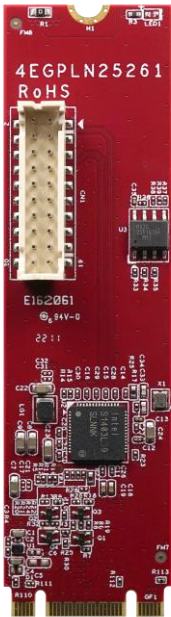

Figure 2: M.2 2280 Board Picture

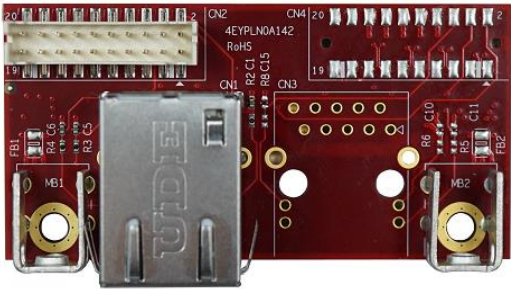

Figure 3: Mounting Hole Daughter Board Picture (EGPL-21S1-C1/W1)

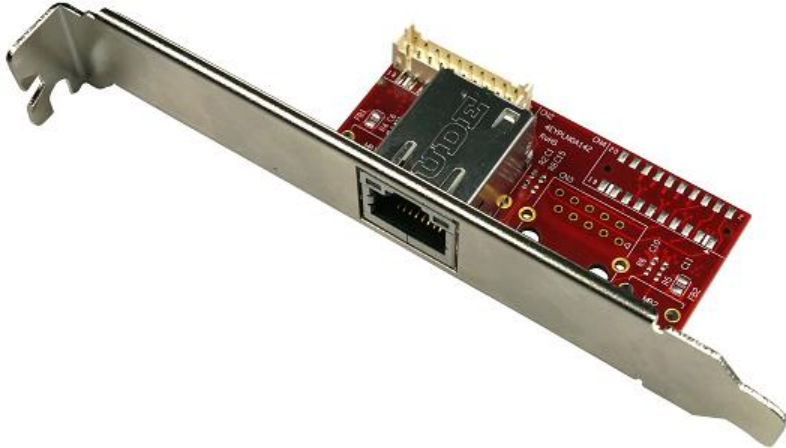

Figure 4: Bracket Daughter Board Picture (EGPL-21S1-C2/W2)

2. Product Specifications

2.1. Device Parameters

Table 1: Device Parameters

Form Factor	M.2 2280 B-M
Input I/F	PCI Express 2.1 x 2
Output I/F	Single 2.5GbE LAN
Output Connector	RJ45 x 1
Dimension (WxLxH)	M.2 Board: 22 x 80 x 9 mm Daughter Board: 30 x 59.5 x 17.32 mm

2.2. Electrical Specifications

2.2.1. Power Requirement

Table 2: Power Requirement

Item	Connector	Rating
Input voltage	M.2 Golden Finger	+3.3 DC +-5%

2.2.2. Power Consumption

Table 3: Power Consumption

Voltage(V)	RMS(mA)	Max (mA)
3.3	251.5	374

2.3. Environmental Specifications

2.3.1. Temperature Ranges

Table 4: Temperature Ranges

Temperature	Range
Operating	Standard Grade: 0°C to +70°C Industrial Grade: -40°C to +85°
Storage	-55°C to +95°

2.3.2. Humidity

Relative Humidity: 10-95%, non-condensing

2.3.3. Shock and Vibration

Table 5: Shock and Vibration

Reliability	Test Conditions	Reference Standards
Vibration	7 Hz to 2K Hz, 20G, 3 axes	IEC 68-2-6
Mechanical Shock	Duration: 0.5ms, 1500 G, 3 axes	IEC 68-2-27

2.3.4. Mean Time between Failure (MTBF)

Reliability prediction methodology provides the basis for reliability evaluation and analysis. The purpose of the prediction is to predict the life time of the product in units of failure rate and MTBF.

Table 6: Mean Time between Failure (MTBF)

Product	Condition	MTBF (Hours)
EGPL-21S1-C1/W1	The analysis is at 25°C ambient temperature by Telcordia SR-332, Issues 4, Method I, Case 3 under Ground Benign, Controlled environment, 50% operation stress	14,394,820
EGPL-21S1-C2/W2	The analysis is at 25°C ambient temperature by Telcordia SR-332, Issues 4, Method I, Case 3 under Ground Benign, Controlled environment, 50% operation stress	15,373,070

2.4. CE and FCC Compatibility

EGPL-21S1 conforms to CE and FCC requirements.

2.5. RoHS Compliance

EGPL-21S1 is fully compliant with RoHS directive.

2.6. Hardware

2.6.1. Layout

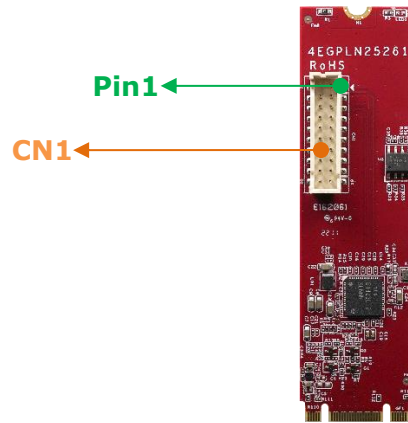

Table 7: M.2 2280 PCB Layout Legend

Label	Connector Type	Function
CN1	Wire to board SMD 2*10P 180° P:2.00mm H:6.5mm	LAN and LED Signal

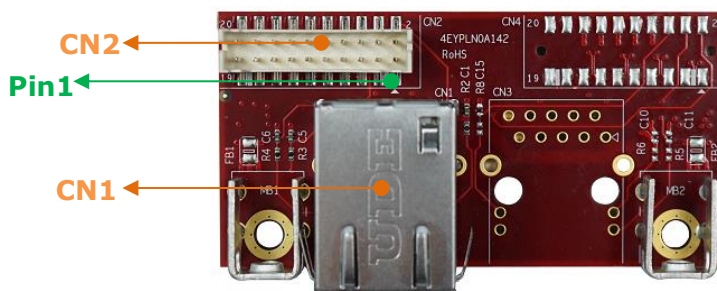
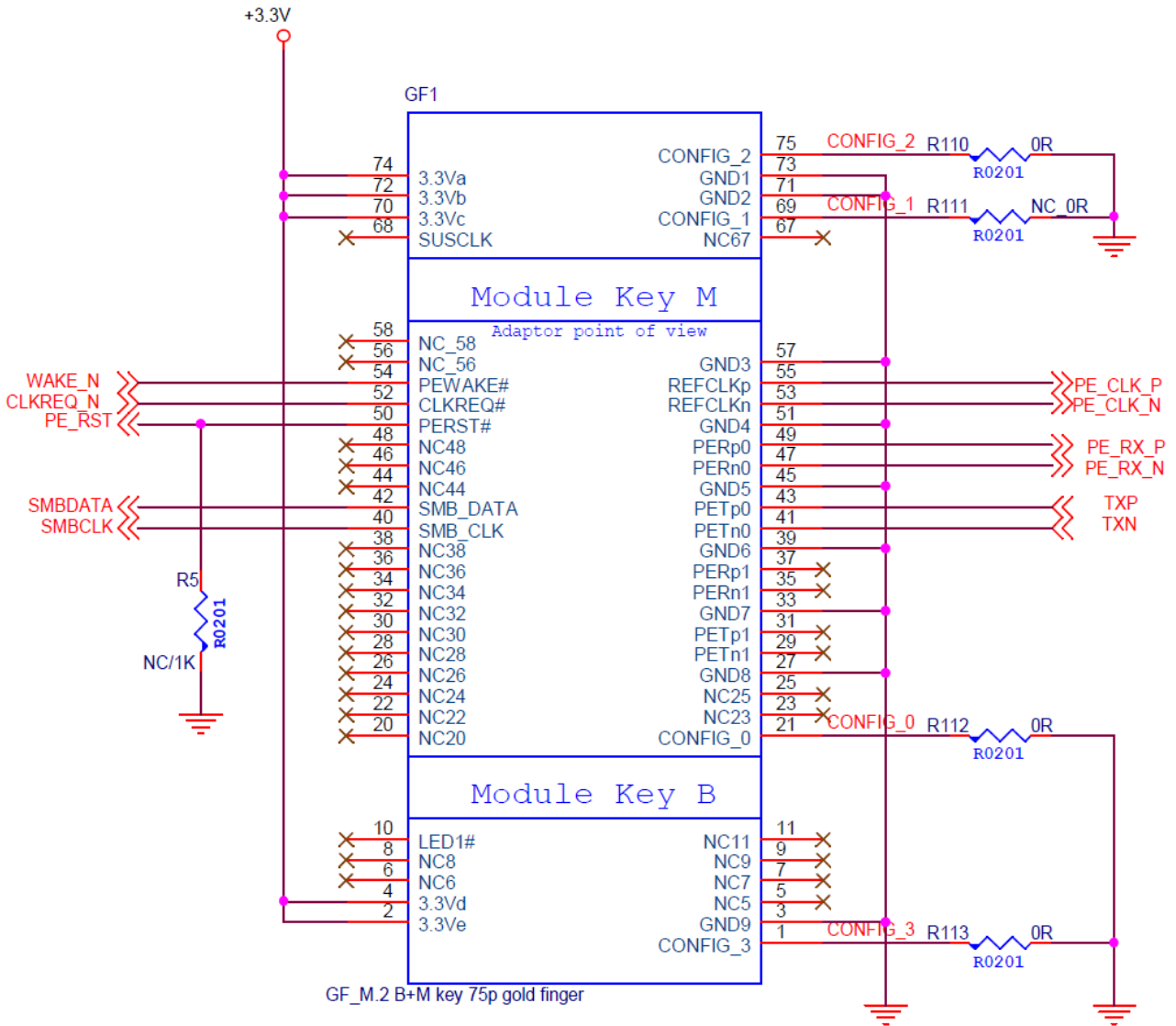

Table 8: Daughter Board PCB Layout Legend

Label	Connector Type	Function
CN1	RJ45/T/U 2.5G Base-T DIP 10P8C 90° LED: Green-Orange/Green	LAN Port LED Indicator
CN2	Wire to board SMD 2*10P 180° P:2.00mm H:6.5mm	LAN and LED Signal

2.6.2. Pin Define

Table 9: M.2 B-M Key Pin Define



2.6.3. I/O Connector Mechanical Drawing & Pin Defines

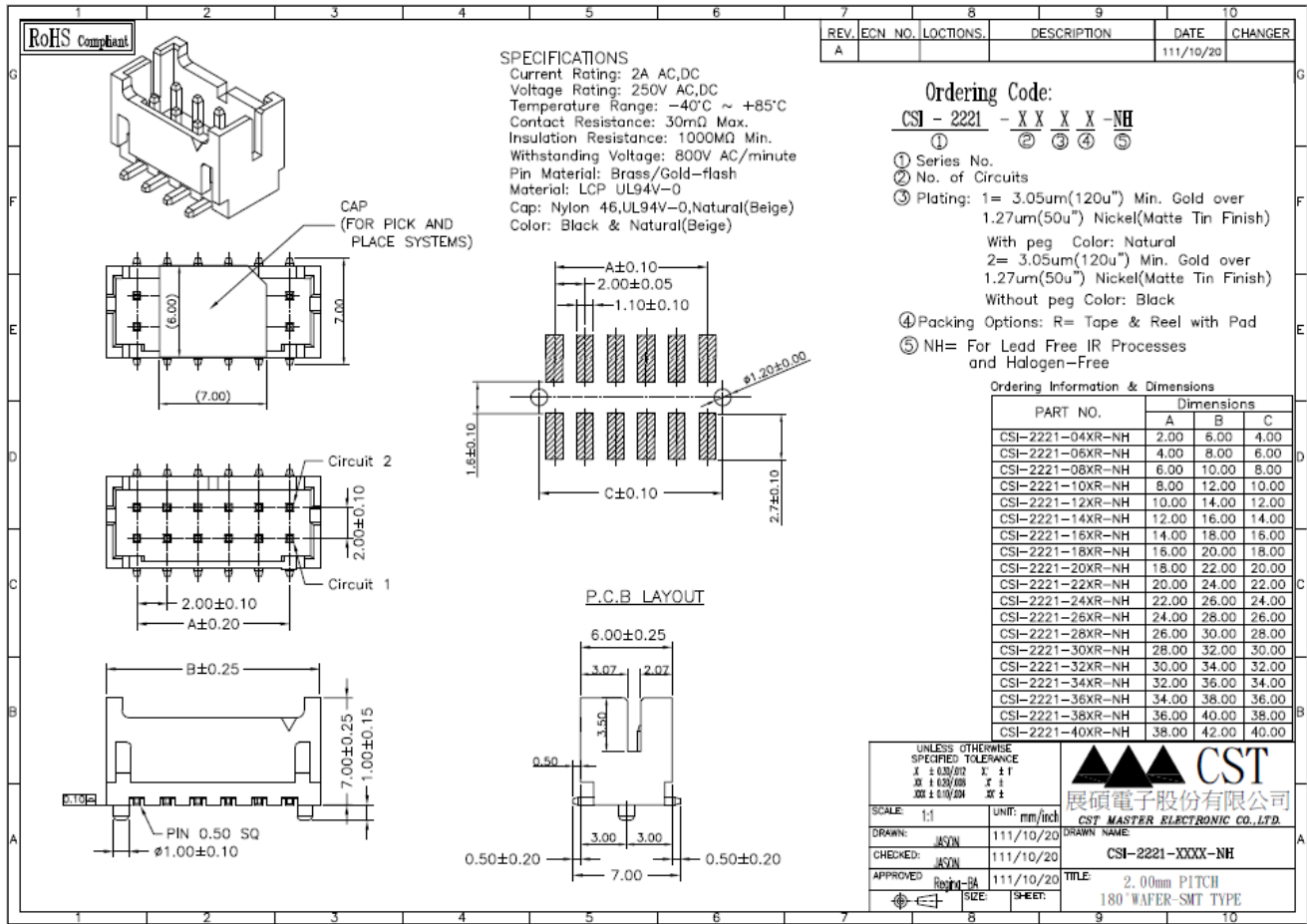

Figure 5: Wire to Board SMD 2*10P Connector Drawing

Table 10: Wire to Board SMD 2*10P Connector Pin Define

Signal Name	Pin #	Pin #	Signal Name
A_SPEED_2500	2	1	MDI0P_IC
A_LINK_ACT_N	4	3	MDI0N_IC
A_LINK_1000_N	6	5	MDI1P_IC
GND	8	7	MDI1N_IC
GND	10	9	MDI2P_IC
GND	12	11	MDI2N_IC
3.3V	14	13	MDI3P_IC
3.3V	16	15	MDI3N_IC
NC	18	17	NC
NC	20	19	NC

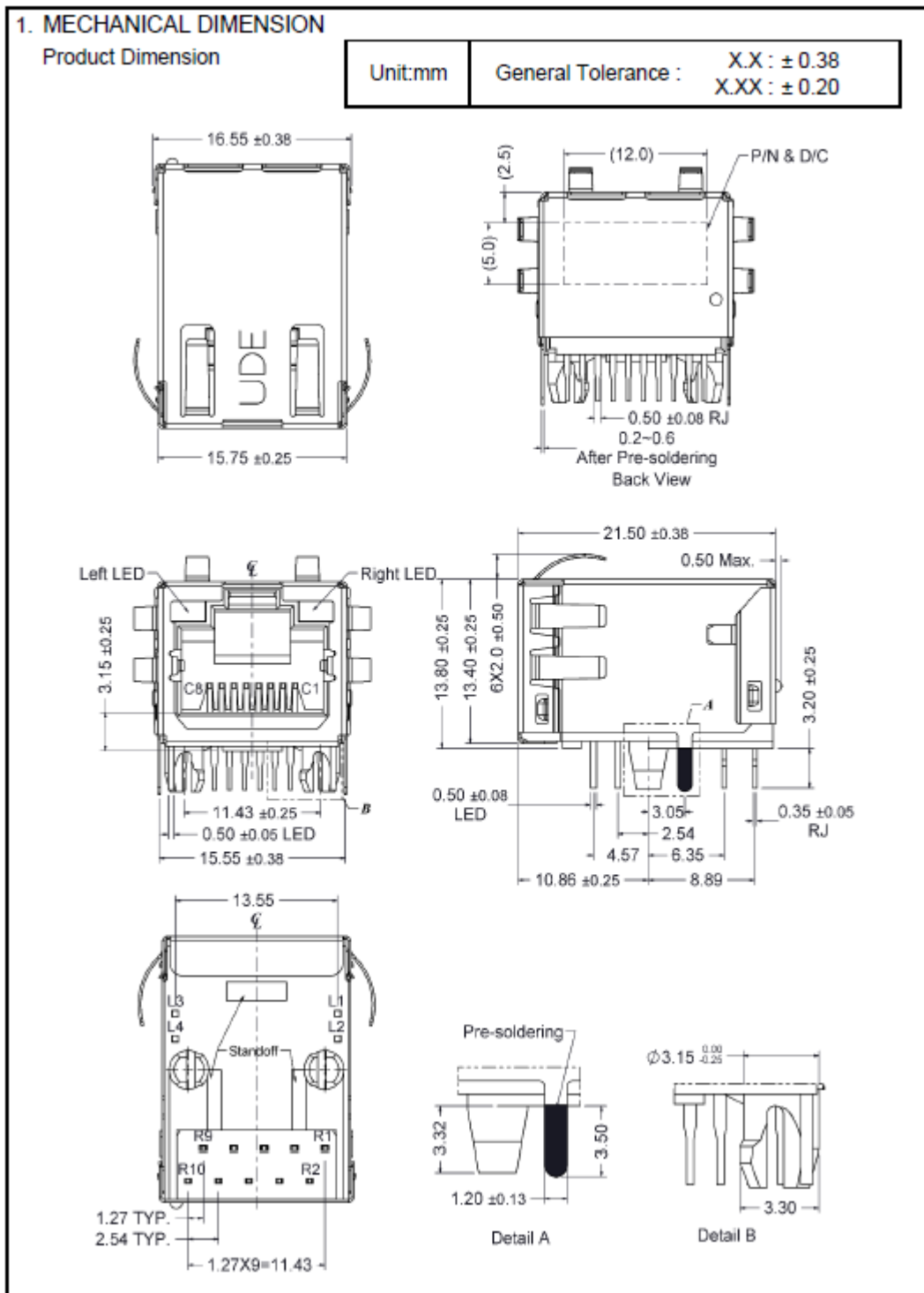
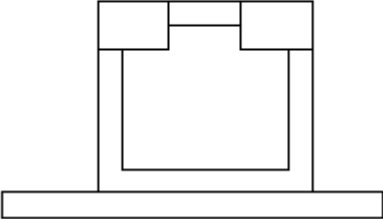

Figure 6: RJ45 Connector Drawing

Table 11: RJ45 LAN LED Table

Orange
/Green Green



Speed LED	
10M	OFF
100M	OFF
1G	Orange
2.5G	Green
Link-Activity LED	
Link-up	Green
Tx/Rx Activity	Blinking Green

2.6.4. EGPL-21S1 Mechanical Drawing

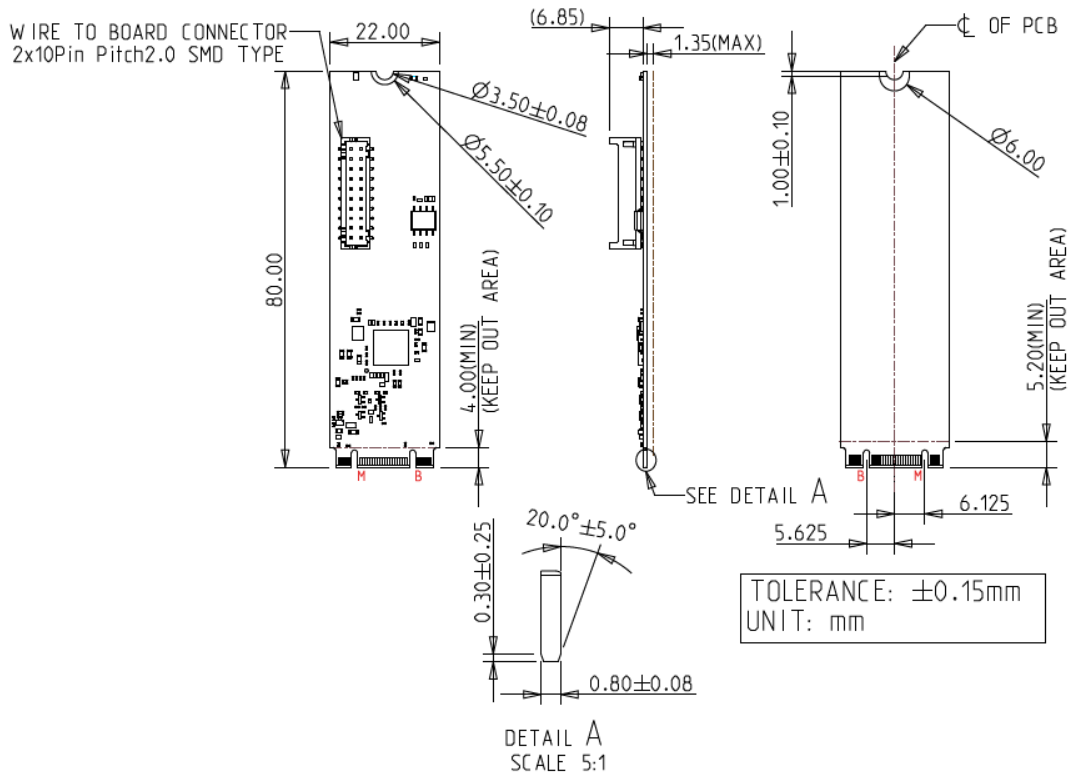

Figure 7: EGPL-21S1 M.2 Board Drawing

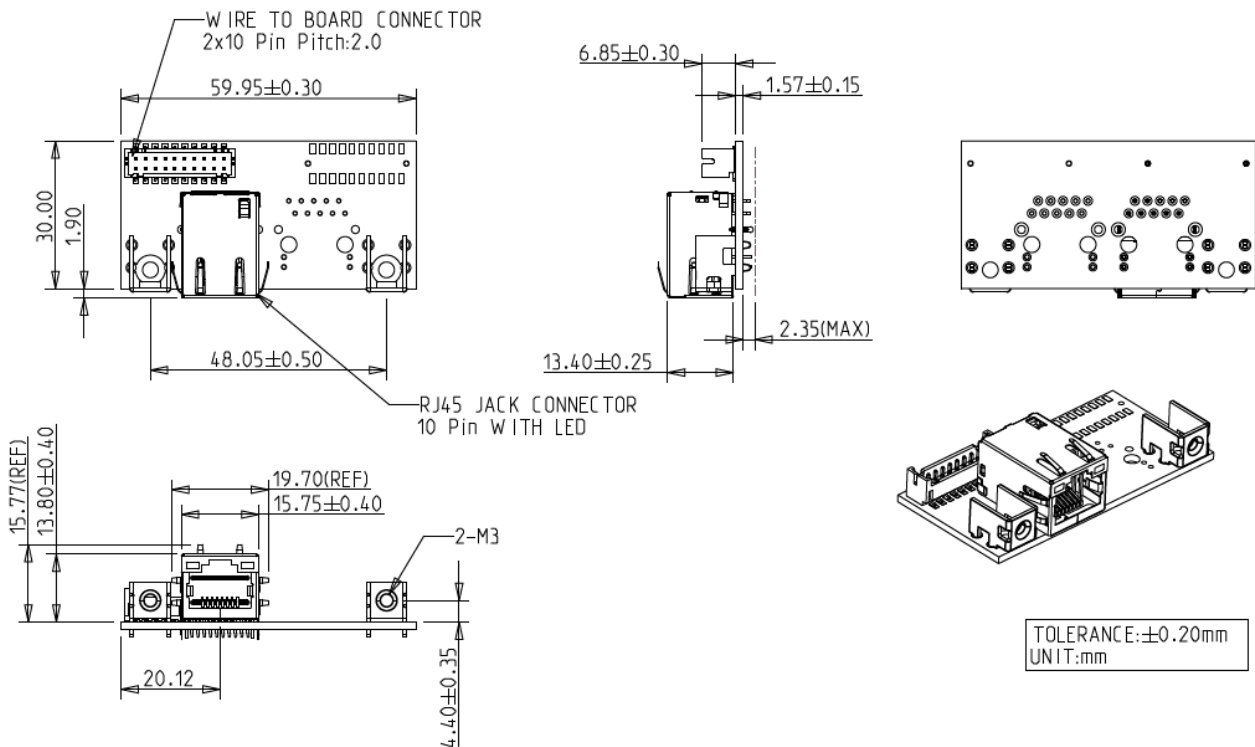

Figure 8: Mounting Hole Daughter Board Drawing (EGPL-21S1-C1/W1)

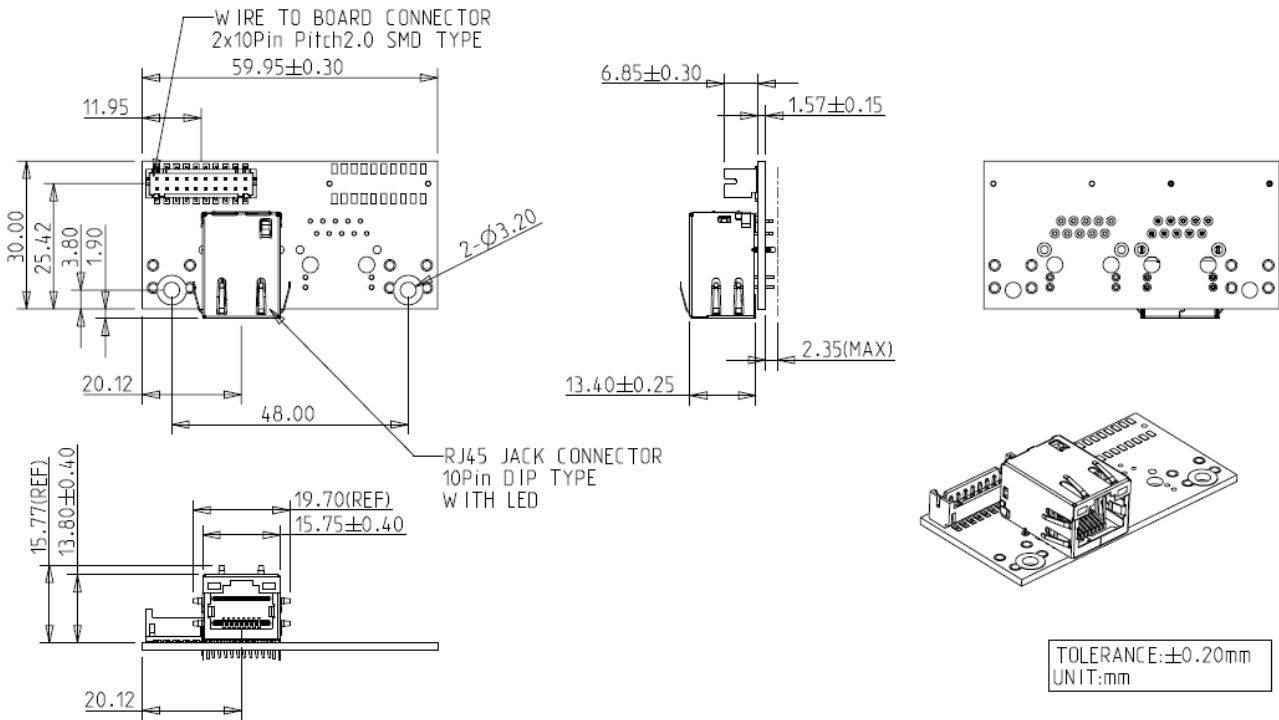

Figure 9: Bracket Daughter Board Drawing (EGPL-21S1-C2/W2)

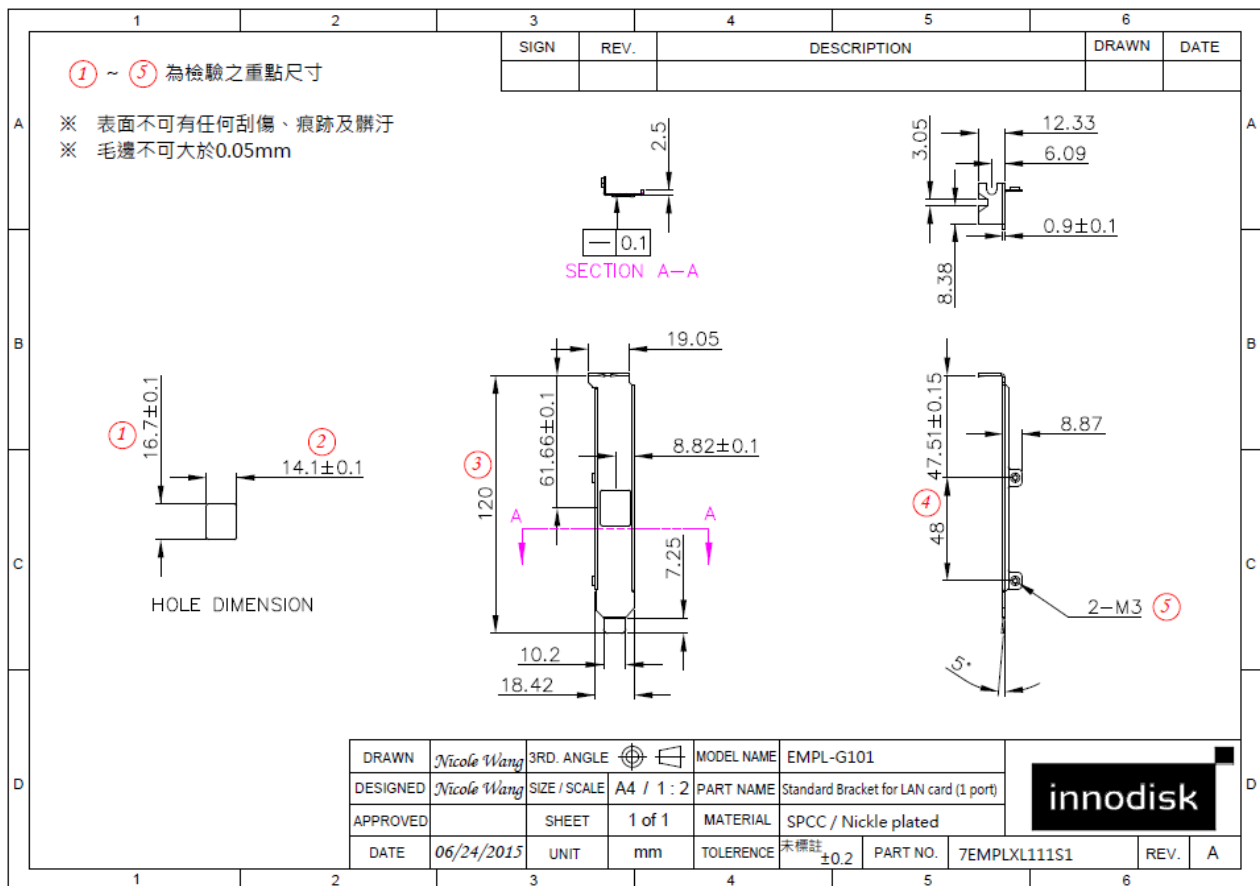

Figure 10: Bracket Drawing

2.6.5. Cable Mechanical Drawing

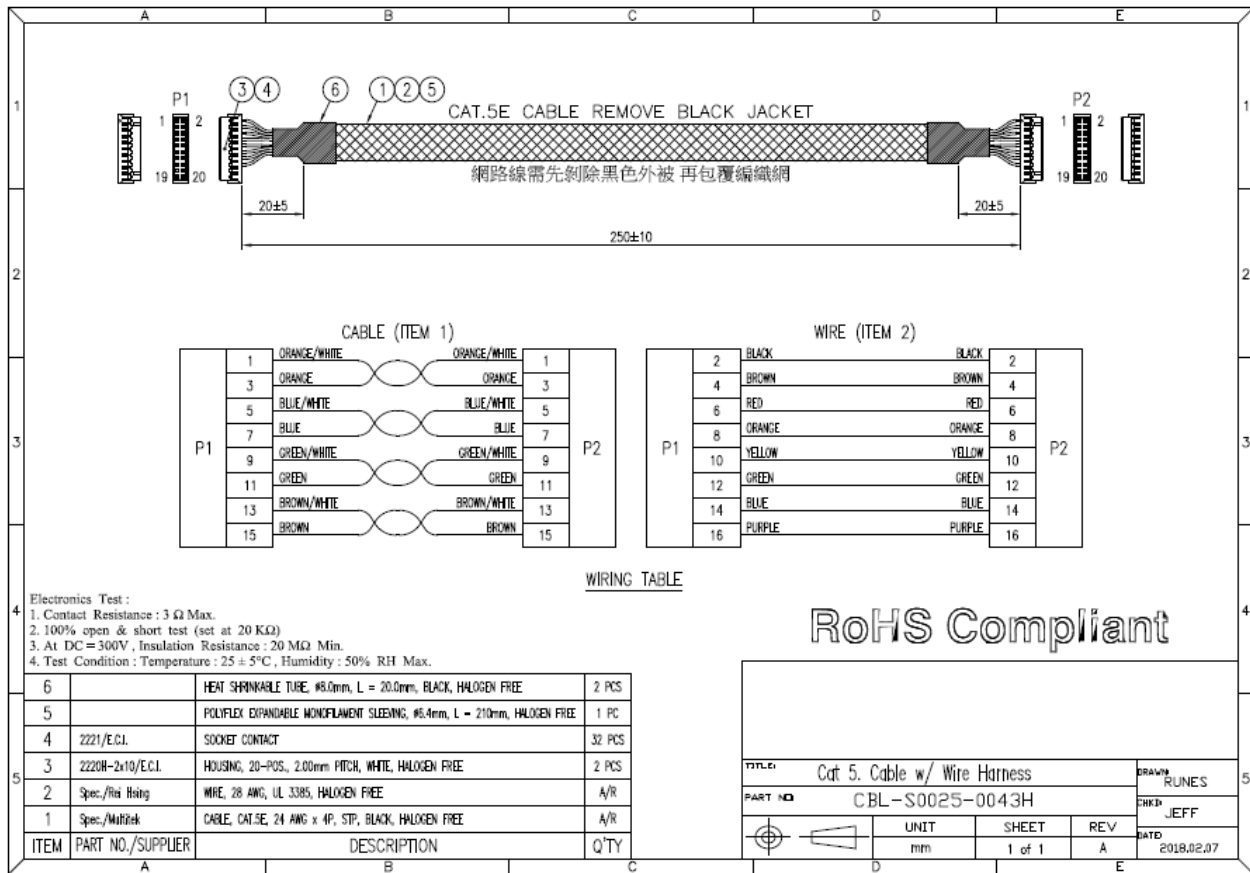

Figure 11: Board to Board LAN Cable Drawing

2.6.6. Packing List

- EGPL-21S1 M.2 Board x 1
- EGPL-21S1 Daughter Board x 1
- Board to Board LAN Cable x 1
- Bracket x 1 (EGPL-21S1-C2/W2 only)
- Screw M3*5 Silver x 2 (EGPL-21S1 C2/W2 only)

2.7. Software Support

Foxville (I225/I226) Operating System Support Matrix:

Operating System / SW	I225 - x86, 64 bit	I226 – x86, 64 bit
Windows 7 / 8 / 8.1	No	
Windows 10 RS5+ / 10S	Yes	
Windows 11	Yes (From ADL, NetAdapterCX)	
Windows Server 2019/2022	Yes (LM/IT sku only)	
Mac OS	Yes (from OS Version 10.16.5)	Yes (from OS Version 12.3)
Linux	Yes (upstream kernel release – from 5.8)	Yes (upstream kernel release – from 5.16.18)
Linux RHEL	Yes RHEL 8.1 (LM/V sku) RHEL 8.3 (IT sku)	Yes RHEL 8.6 (LM/-V/-IT)
DPDK	Yes (from 20.05)	Yes (from 22.07)
FreeBSD	Yes	
Legacy PXE	Yes	Yes (UEFI PXE only)
UEFI 2.4	Yes	
Manufacturing / NVM Programing Tools	Supported on Windows, Linux, x86 Architecture only	

3. Installation Guide

Please download driver from Myinnodisk web site.

<https://myinnodisk.innodisk.com/myinnodisk/Login.aspx>

Windows driver still can be downloaded from intel official website.

<https://www.intel.com/content/www/us/en/download/15084/intel-ethernet-adapter-complete-driver-pack.html>

Intel dosen't provide i226 Linux driver for download.

Up Stream Kernel Release from 5.16.18.

4. Appedix

innodisk

宜鼎國際股份有限公司
Innodisk Corporation
REACH Declaration

Tel:(02)7703-3000 Fax:(02) 7703-3555 Internet: <https://www.innodisk.com/>

Innodisk Corporation pursues its social responsibility for global environmental preservation by committing to be compliant with REACH regulation (REGULATION (EC) No 1907/2006). We hereby confirm that the product(s),

Scope: Flash Memory, DRAM Module and Embedded Peripherals Products.

- The standard products of **not listed** in the **Appendix2** meet the requirements of REACH SVHC regulations(SVHCs < 0.1% in Article), as described in the candidate list table currently including 233 substances (release date: 17-Jan-2023) and shown on the ECHA website. <https://echa.europa.eu/candidate-list-table>
- The standard products listed in the **Appendix2** contain(s) one or more hazardous substances or constituents exceeding 0.1 % by weight in article if not otherwise specified in candidate list table.
Where the threshold value is exceeded, the substances in question are to be declared in accompanying. (SVHCs > 0.1% in Article).
- Comply with REACH Annex XVII.

Guarantor



Company name 公司名稱： Innodisk Corporation 宜鼎國際股份有限公司

Company Representative 公司代表人：  Yichuan Chen 陳怡全

Company Representative Title 公司代表人職稱： QA Manager 品保經理

Date 日期： 2023 / 02 / 09

RoHS 自我宣告書 (RoHS Declaration of Conformity)

Manufacturer Products: All Innodisk EM FLASH, DRAM and EP products

- 一、宜鼎國際股份有限公司（以下稱本公司）特此保證售予貴公司之所有產品，皆符合歐盟 2011/65/EU 及 (EU) 2015/863 關於 RoHS 之規範要求。
Innodisk Corporation declares that all products sold to the company, are complied with European Union RoHS Directive (2011/65/EU) and (EU) 2015/863 requirement.
- 二、本公司同意因本保證書或與本保證書相關事宜有所爭議時，雙方宜友好協商，達成協議。
Innodisk Corporation agrees that both parties shall settle any dispute arising from or in connection with this Declaration of Conformity by friendly negotiations.
- 三、本公司聲明我們的產品符合 RoHS 指令的附件中 7(a)、7(c)-I、6(c) 允許豁免。
We declare, our products permitted by the following exemptions specified in the Annex of the RoHS directive.
- ※ 7(a) Lead in high melting temperature type solders (i.e. lead-based alloys containing 85% by weight or more lead).
 - ※ 7(c)-I Electrical and electronic components containing lead in a glass or ceramic other than dielectric ceramic in capacitors, e.g. piezoelectric devices, or in a glass or ceramic matrix compound.
 - ※ 6(c) Copper alloy containing up to 4% lead by weight. (This exemption applies to products that use antennas)

Name of hazardous substance	Limited of RoHS ppm (mg/kg)
鉛 (Pb)	< 1000 ppm
汞 (Hg)	< 1000 ppm
鎘 (Cd)	< 100 ppm
六價鉻 (Cr 6+)	< 1000 ppm
多溴聯苯 (PBBs)	< 1000 ppm
多溴二苯醚 (PBDEs)	< 1000 ppm
鄰苯二甲酸二(2-乙基己基)酯 (DEHP)	< 1000 ppm
鄰苯二甲酸丁酯苯甲酯 (BBP)	< 1000 ppm
鄰苯二甲酸二丁酯 (DBP)	< 1000 ppm
鄰苯二甲酸二異丁酯 (DIBP)	< 1000 ppm

宜鼎國際股份有限公司
Innodisk Corporation

立 保 證 書 人 (Guarantor)

Company name 公司名稱： Innodisk Corporation 宜鼎國際股份有限公司

Company Representative 公司代表人： 簡川勝

Company Representative Title 公司代表人職稱： Chairman 董事長

Date 日期： 2023 / 06 / 14





Statement of Conformity

Issued Date: Nov. 06, 2023
Report No. : 2390756R-0E3012100115-A

This is to certify that the following designated product

Product : M.2 to Single Isolated 2.5GbE LAN Module
Trademark : Innodisk
Model Number : EGPL-21S1
Company Name : Innodisk Corporation

This product, which has been issued the test report listed as above in DEKRA Testing and Certification Co., Ltd. Laboratory, is based on a single evaluation of one sample and confirmed to comply with the requirements of the following EMC standard.

EN 55032:2015/A1:2020, Class B	EN 55035:2017/A11:2020
	IEC 61000-4-2 Ed. 2.0:2008
	IEC 61000-4-3 Ed. 4.0:2020
	IEC 61000-4-4 Ed. 3.0:2012
	IEC 61000-4-6 Ed. 4.0:2013
	IEC 61000-4-8 Ed. 2.0:2009

TEST LABORATORY

A handwritten signature in black ink, appearing to read 'Vincent Lin'.

Vincent Lin / Director

DEKRA Testing and Certification Co., Ltd.
No. 5-22, Ruishukeng, Linkou Dist., New Taipei City 24451, Taiwan
TEL:+886-2-8601-3788 FAX:+886-2-8601-3789 Email: info.tw@dekra.com <http://www.dekra.com.tw>



Statement of Conformity

Issued Date: Nov. 06, 2023
Report No. : 2390756R-0E3012110014-A

This is to certify that the following designated product

Product : M.2 to Single Isolated 2.5GbE LAN Module
Trademark : Innodisk
Model Number : EGPL-21S1
Company Name : Innodisk Corporation

This product, which has been issued the test report listed as above in DEKRA Testing and Certification Co., Ltd. Laboratory, is based on a single evaluation of one sample and confirmed to comply with the requirements of the following EMC standard.

FCC CFR Title 47 Part 15 Subpart B:2021, Class B

TEST LABORATORY

A handwritten signature in black ink, appearing to read 'Vincent Lin', written over a horizontal line.

Vincent Lin / Director

DEKRA Testing and Certification Co., Ltd.
No. 5-22, Ruishukeng, Linkou Dist., New Taipei City 24451, Taiwan
TEL:+886-2-8601-3788 FAX:+886-2-8601-3789 Email: info.tw@dekra.com <http://www.dekra.com.tw>



Statement of Conformity

Issued Date: Nov. 06, 2023
Report No. : 2390756R-0E3012100115-A

This is to certify that the following designated product

Product : M.2 to Single Isolated 2.5GbE LAN Module
Trademark : Innodisk
Model Number : EGPL-21S1
Company Name : Innodisk Corporation

This product, which has been issued the test report listed as above in DEKRA Testing and Certification Co., Ltd. Laboratory, is based on a single evaluation of one sample and confirmed to comply with the requirements of the following EMC standard.

BS EN 55032:2015+A1:2020, Class B **BS EN 55035:2017+A11:2020**
BS EN 61000-4-2:2009
BS EN IEC 61000-4-3:2020
BS EN 61000-4-4:2012
BS EN 61000-4-6:2014
BS EN 61000-4-8:2010

TEST LABORATORY

A handwritten signature in black ink, appearing to read 'Vincent Lin'.

Vincent Lin / Director

DEKRA Testing and Certification Co., Ltd.
No. 5-22, Ruishukeng, Linkou Dist., New Taipei City 24451, Taiwan
TEL:+886-2-8601-3788 FAX:+886-2-8601-3789 Email: info.tw@dekra.com <http://www.dekra.com.tw>



Statement of Conformity

Issued Date: Nov. 06, 2023
Report No. : 2390756R-0E3012150009-A

This is to certify that the following designated product

Product : M.2 to Single Isolated 2.5GbE LAN Module
Trademark : Innodisk
Model Number : EGPL-21S1
Company Name : Innodisk Corporation

This product, which has been issued the test report listed as above in DEKRA Testing and Certification Co., Ltd. Laboratory, is based on a single evaluation of one sample and confirmed to comply with the requirements of the following EMC standard.

ICES-003 Issue 7:2020, Class B

TEST LABORATORY

A handwritten signature in black ink, appearing to read 'Vincent Lin'.

Vincent Lin / Director

DEKRA Testing and Certification Co., Ltd.
No. 5-22, Ruishukeng, Linkou Dist., New Taipei City 24451, Taiwan
TEL:+886-2-8601-3788 FAX:+886-2-8601-3789 Email: info.tw@dekra.com <http://www.dekra.com.tw>

Contact us

Headquarters (Taiwan)

5F., No. 237, Sec. 1, Datong Rd., Xizhi Dist., New Taipei City 221, Taiwan

Tel: +886-2-77033000

Email: sales@innodisk.com

Branch Offices:

USA

usasales@innodisk.com

+1-510-770-9421

Europe

eusales@innodisk.com

+31-40-3045-400

Japan

jpsales@innodisk.com

+81-3-6667-0161

China

sales_cn@innodisk.com

+86-755-2167-3689

www.innodisk.com

© 2023 Innodisk Corporation.

All right reserved. Specifications are subject to change without prior notice.

January 12, 2024