

Features

- Single isolated GbE LAN port
- Complies with EN61000-4-5 2kV Surge protection
- Complies with IEC 60950-1:2005 + A1: 2009 + A2:2013 2kV HiPOT protection
- Complies with EN61000-4-2 (ESD) Air-15kV, Contact-8kV
- Flexible daughter board with cable to fit into different system
- Optional terminal mounting hole or bracket for daughter board
- Optional Industrial Temperature (-40°C to +85°C) support
- 30μ " golden finger, 3 years warranty
- Industrial design, manufactured in Innodisk Taiwan

Mechanical Drawing

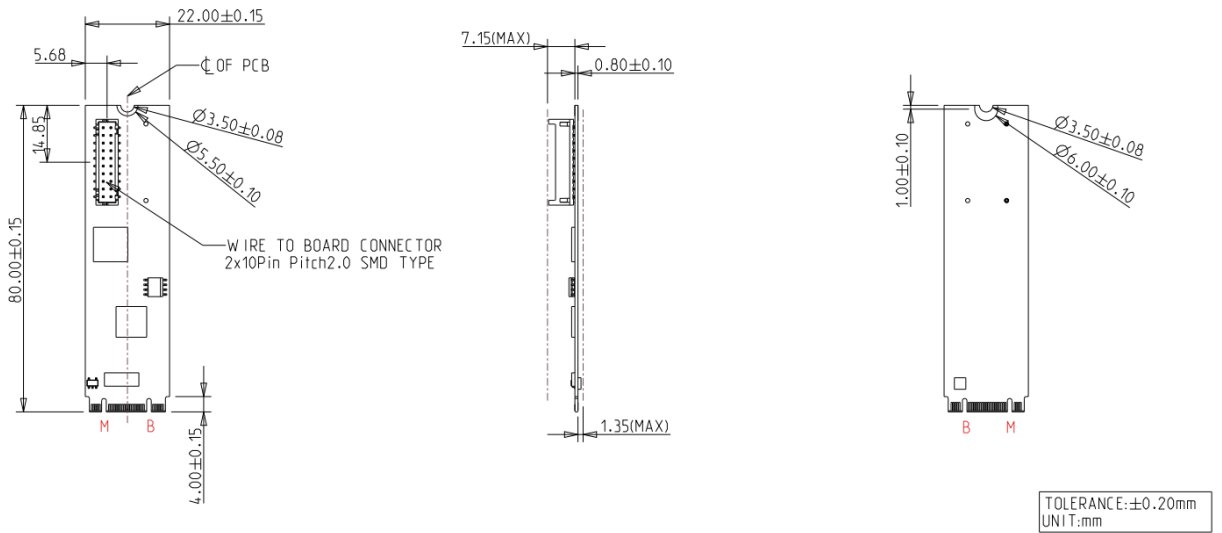

Specifications

Form-Factor	M.2 2280 B-M
Input I/F	PCI Express 2.1 x 1
Output I/F	Single GbE LAN
Output Connector	RJ45 x 1
Power Consumption	0.66W (3.3V x 200mA)
Dimension (WxLxH)	22 x 80 x 9.3 mm
Temperature	Operation: STD: 0°C ~ +70°C. W/T: -40°C ~ +85°C Storage: -55°C ~ +95°C
Environment	Vibration: 5G @7~2000Hz, Shock: 50G @ 0.5ms
Notes	Please download driver from Intel official website. Windows: XP(32bit), 7(32/64bit), 8/8.1(32/64 bit), 10(32/64bit) Linux: kernel 2.4 series, 2.6.x and 3.x version.

Headquarters (Taiwan)

5F., No.237, Sec. 1, Datong Rd.,
Xizhi Dist., New Taipei City 221,
Taiwan

Tel: +886-2-7703-3000
Email: sales@innodisk.com

Branch Offices:

USA

usasales@innodisk.com
+1-510-770-9421

Europe

eusales@innodisk.com
+31-040-3045-400

Japan

jpsales@innodisk.com
+81-3-6667-0161

China

sales_cn@innodisk.com
+86-755-2167-3689

www.innodisk.com

© 2022 Innodisk Corporation.
All right reserved. Specifications
are subject to change without
prior notice.

November 26, 2022

Order information

EGPL-G101-C1 (Terminal mounting hole, Standard Temp.)

EGPL-G101-W1 (Terminal mounting hole, Wide Temp.)

EGPL-G101-C2 (Bracket, Standard Temp.)

EGPL-G101-W2 (Bracket, Wide Temp.)

M.2 to Single GbE LAN Module

EGPL-G101-C1/W1 Daughter Board and Mechanical Drawing

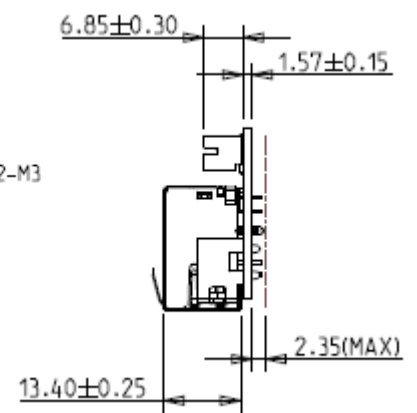
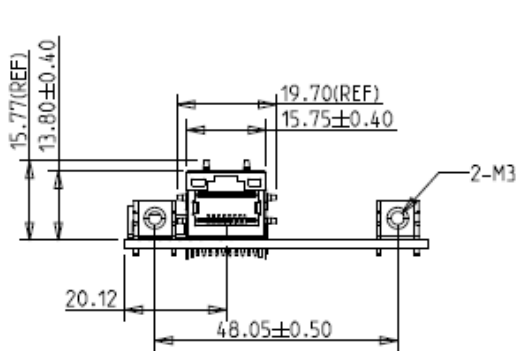
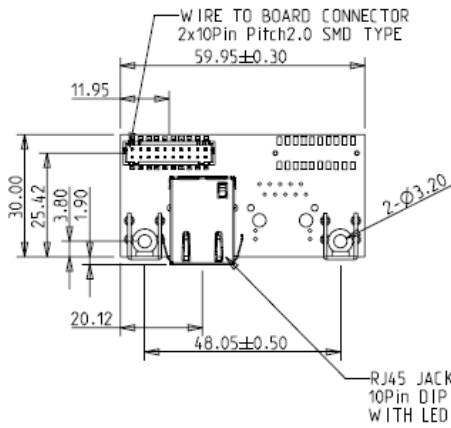
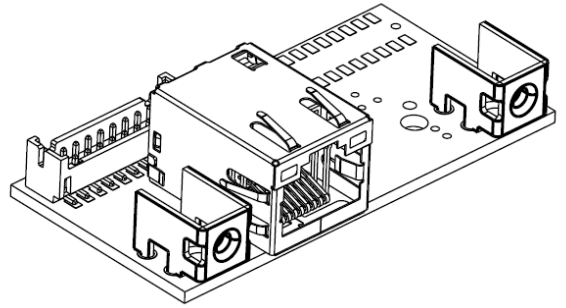
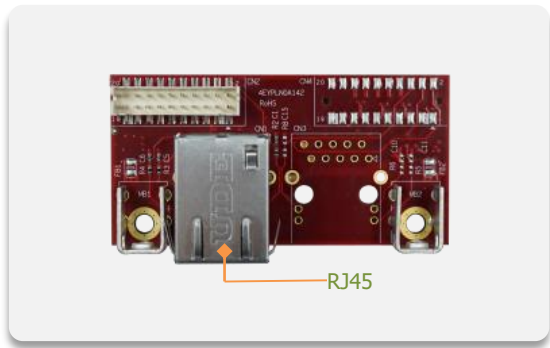

EGPL-G101-C2/W2 Daughter Board and Mechanical Drawing

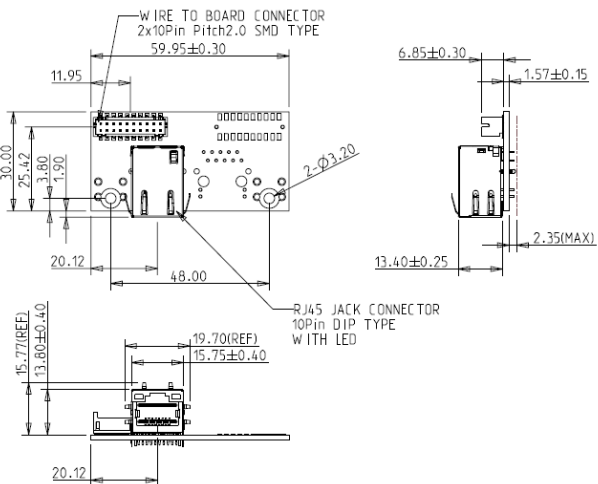
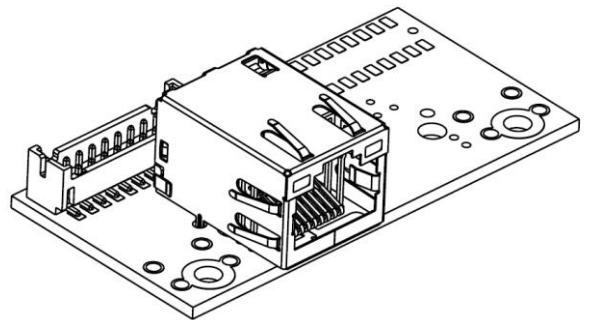
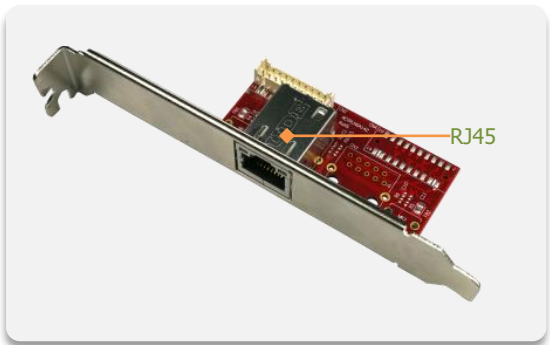

Bracket

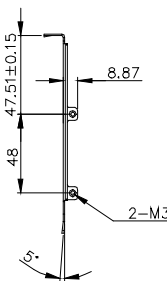
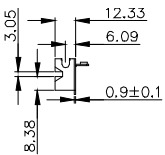
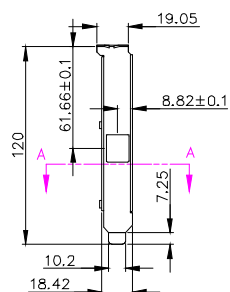
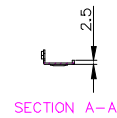
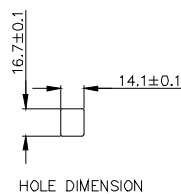

TOLERANCE: ±0.20mm