

# EGPL-G2N1

## M.2 2280 to dual GbE LAN module

**Customer:**

---

**Customer**

**Part Number:**

---

**Innodisk**

**Part Number:**

---

**Innodisk**

**Model Name:**

---

**Date:**

---

<b>Innodisk</b>	<b>Customer</b>
<b>Approver</b>	<b>Approver</b>

## Table of Contents

<b>TABLE OF CONTENTS</b> .....	<b>I</b>
<b>REVISION HISTORY</b> .....	<b>II</b>
<b>LIST OF TABLES</b> .....	<b>1</b>
<b>LIST OF FIGURES</b> .....	<b>2</b>
<b>1. PRODUCT INTRODUCTION</b> .....	<b>3</b>
1.1. OVERVIEW .....	3
1.2. FEATURES .....	3
<b>2. PRODUCT SPECIFICATIONS</b> .....	<b>5</b>
2.1. DEVICE PARAMETERS .....	5
2.2. ELECTRICAL SPECIFICATIONS .....	5
2.2.1. POWER REQUIREMENT .....	5
2.2.2. POWER CONSUMPTION .....	5
2.3. ENVIRONMENTAL SPECIFICATIONS .....	5
2.3.1. TEMPERATURE RANGES .....	5
2.3.2. HUMIDITY .....	6
2.3.3. SHOCK AND VIBRATION .....	6
2.3.4. MEAN TIME BETWEEN FAILURE (MTBF) .....	6
2.4. CE AND FCC COMPATIBILITY .....	6
2.5. ROHS COMPLIANCE .....	6
2.6. HARDWARE .....	7
2.6.1. LAYOUT .....	7
2.6.2. PIN DEFINE .....	8
2.6.3. I/O CONNECTOR MECHANICAL DRAWING & PIN DEFINES .....	9
2.6.4. EGPL-G2N1 MECHANICAL DRAWING .....	11
2.6.5. CABLE MECHANICAL DRAWING .....	11
2.6.6. PACKING LIST .....	12
2.7. SOFTWARE SUPPORT .....	12
<b>3. INSTALLATION GUIDE</b> .....	<b>12</b>
<b>4. APPEDIX</b> .....	<b>13</b>
<b>CONTACT US</b> .....	<b>16</b>

## REVISION HISTORY

Revision	Description	Date
1.0	First Released	Nov, 2022

## List of Tables

<b>TABLE 1: DEVICE PARAMETERS .....</b>	<b>5</b>
<b>TABLE 2: POWER REQUIREMENT.....</b>	<b>5</b>
<b>TABLE 3: POWER CONSUMPTION .....</b>	<b>5</b>
<b>TABLE 4: TEMPERATURE RANGES.....</b>	<b>5</b>
<b>TABLE 5: SHOCK AND VIBRATION .....</b>	<b>6</b>
<b>TABLE 6: MEAN TIME BETWEEN FAILURE (MTBF).....</b>	<b>6</b>
<b>TABLE 7: M.2 PCB LAYOUT LEGEND .....</b>	<b>7</b>
<b>TABLE 8: M.2 PIN DEFINE.....</b>	<b>8</b>
<b>TABLE 9: WIRE TO BOARD SMD 2*10P CONNECTOR (CN1) PIN DEFINE .....</b>	<b>9</b>
<b>TABLE 10: 2X5 PIN HEADER (CN2) PIN DEFINE .....</b>	<b>10</b>
<b>TABLE 11: LAN LED TABLE.....</b>	<b>10</b>

### List of Figures

<b>FIGURE 1: BLOCK DIAGRAM .....</b>	<b>3</b>
<b>FIGURE 2: M.2 2280 BOARD PICTURE.....</b>	<b>4</b>
<b>FIGURE 3: 20PIN PITCH 2.0 CONNECTOR TO 2 RJ45 CABLE.....</b>	<b>4</b>
<b>FIGURE 4: WIRE TO BOARD SMD 2*10P CONNECTOR DRAWING.....</b>	<b>9</b>
<b>FIGURE 5: EGPL-G2N1 M.2 BOARD DRAWING .....</b>	<b>11</b>
<b>FIGURE 6: 20PIN PITCH 2.0 CONNECTOR TO 2 RJ45 CABLE DRAWING .....</b>	<b>11</b>

# 1. Product Introduction

## 1.1. Overview

Innodisk EGPL-G2N1 is designed with standard M.2 2280 form factor, EGPL-G2N1 supports PCIe Gen 2.1 with a single lane to dual independent GbE LAN, optimized for higher performance and lower power. EGPL-G2N1 is designed with on-board transformer which brings you a flexible cable design for small form factor or embedded systems.

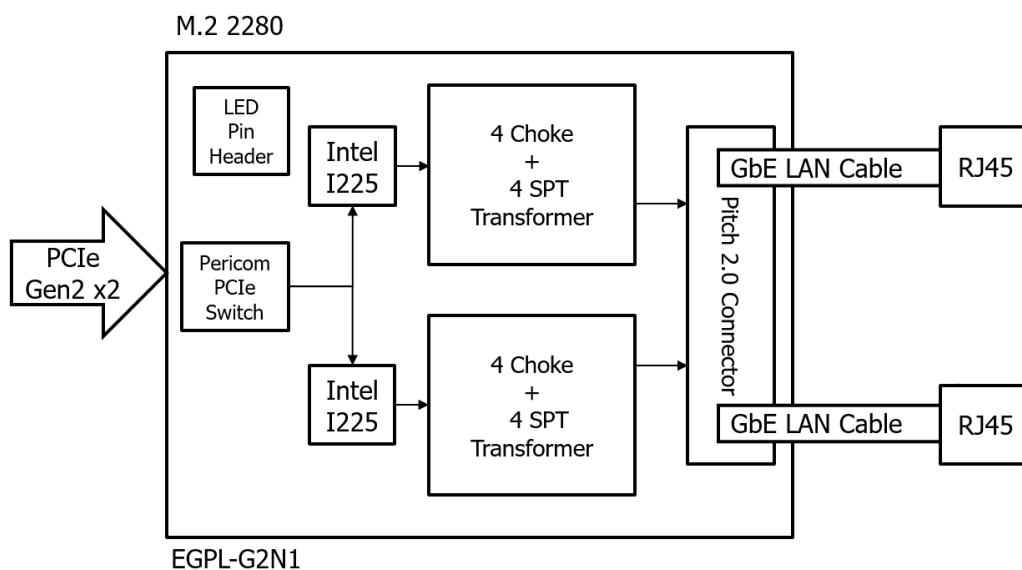

**Figure 1: Block Diagram**

## 1.2. Features

- Dual GbE LAN ports
- Complies with EN61000-4-2 (ESD) Air-15kV, Contact-8kV
- Transformer on PCB for flexible cable design
- External LED indicator pin for speed 10/100/1000
- Optional Industrial Temperature (-40°C to +85°C) support
- 30μ" golden finger, 3-year warranty
- Industrial design, manufactured in innodisk Taiwan



**Figure 2: M.2 2280 Board Picture**



**Figure 3: 20pin Pitch 2.0 Connector to 2 RJ45 Cable**

## 2. Product Specifications

### 2.1. Device Parameters

**Table 1: Device Parameters**

<b>Form Factor</b>	M.2 2280
<b>Input I/F</b>	PCI Express 2.1 x 1
<b>Output I/F</b>	Dual GbE LAN
<b>Output Connector</b>	RJ45 x 2
<b>Dimension (WxLxH)</b>	22 x 80 x 9 mm

### 2.2. Electrical Specifications

#### 2.2.1. Power Requirement

**Table 2: Power Requirement**

Item	Connector	Rating
Input voltage	M.2 Golden Finger	+3.3 DC +-5%

#### 2.2.2. Power Consumption

**Table 3: Power Consumption**

Voltage (V)	RMS (mA)	MAX (mA)
3.3	737.8	831

### 2.3. Environmental Specifications

#### 2.3.1. Temperature Ranges

**Table 4: Temperature Ranges**

Temperature	Range
Operating	Standard Grade: 0°C to +70°C Industrial Grade: -40°C to +85°
Storage	-55°C to +95°



### 2.3.2. Humidity

Relative Humidity: 10-95%, non-condensing

### 2.3.3. Shock and Vibration

**Table 5: Shock and Vibration**

Reliability	Test Conditions	Reference Standards
Vibration	7 Hz to 2K Hz, 20G, 3 axes	IEC 68-2-6
Mechanical Shock	Duration: 0.5ms, 1500 G, 3 axes	IEC 68-2-27

### 2.3.4. Mean Time between Failure (MTBF)

Reliability prediction methodology provides the basis for reliability evaluation and analysis. The purpose of the prediction is to predict the life time of the product in units of failure rate and MTBF.

**Table 6: Mean Time between Failure (MTBF)**

Product	Condition	MTBF (Hours)
EGPL-G2N1-C1	The analysis is at 25°C ambient temperature by Telcordia SR-332, Issues 4, Method I, Case 3 under Ground Benign, Controlled environment, 50% operation stress	8,529,214
EGPL-G2N1-W1	The analysis is at 25°C ambient temperature by Telcordia SR-332, Issues 4, Method I, Case 3 under Ground Benign, Controlled environment, 50% operation stress	8,529,214

### 2.4. CE and FCC Compatibility

EGPL-G2N1 conforms to CE and FCC requirements.

### 2.5. RoHS Compliance

EGPL-G2N1 is fully compliant with RoHS directive.

## 2.6. Hardware

### 2.6.1. Layout

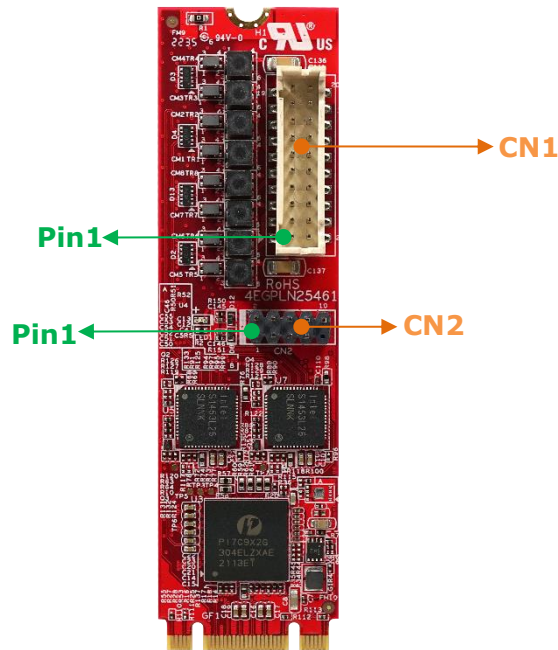

**Table 7: M.2 PCB Layout Legend**

Label	Connector Type	Function
<b>CN1</b>	Wire to board SMD 2*10P 180° P:2.0mm H:4.0mm	GbE LAN Signal
<b>CN2</b>	2x5 Pin Header (cut 9pin) P:2.0mm	10/100/1000 LED Signal

## 2.6.2. Pin Define

Table 8: M.2 Pin Define

Signal Name	Pin #	Pin #	Signal Name
		<b>75</b>	CONFIG_2 (GND)
3.3V	<b>74</b>	<b>73</b>	GND
3.3V	<b>72</b>	<b>71</b>	GND
3.3V	<b>70</b>	<b>69</b>	NC
NC	<b>68</b>	<b>67</b>	NC
<b>Module Key M</b>			
NC	<b>58</b>		
NC	<b>56</b>	<b>57</b>	GND
PE_WAKE_N	<b>54</b>	<b>55</b>	CLK+
GND	<b>52</b>	<b>53</b>	CLK-
PE_RST	<b>50</b>	<b>51</b>	GND
NC	<b>48</b>	<b>49</b>	RX0+
NC	<b>46</b>	<b>47</b>	RX0-
NC	<b>44</b>	<b>45</b>	GND
SMBDATA	<b>42</b>	<b>43</b>	TX0+
SMBCLK	<b>40</b>	<b>41</b>	TX0-
NC	<b>38</b>	<b>39</b>	GND
NC	<b>36</b>	<b>37</b>	RX1+
NC	<b>34</b>	<b>35</b>	RX1-
NC	<b>32</b>	<b>33</b>	GND
NC	<b>30</b>	<b>31</b>	TX1+
NC	<b>28</b>	<b>29</b>	TX1-
NC	<b>26</b>	<b>27</b>	GND
NC	<b>24</b>	<b>25</b>	NC
NC	<b>22</b>	<b>23</b>	NC
NC	<b>20</b>	<b>21</b>	CONFIG_0 (GND)
<b>Module Key B</b>			
NC	<b>10</b>	<b>11</b>	NC
NC	<b>8</b>	<b>9</b>	NC
NC	<b>6</b>	<b>7</b>	NC
3.3V	<b>4</b>	<b>5</b>	NC
3.3V	<b>2</b>	<b>3</b>	GND
		<b>1</b>	CONFIG_3 (GND)

2.6.3. I/O Connector Mechanical Drawing & Pin Defines

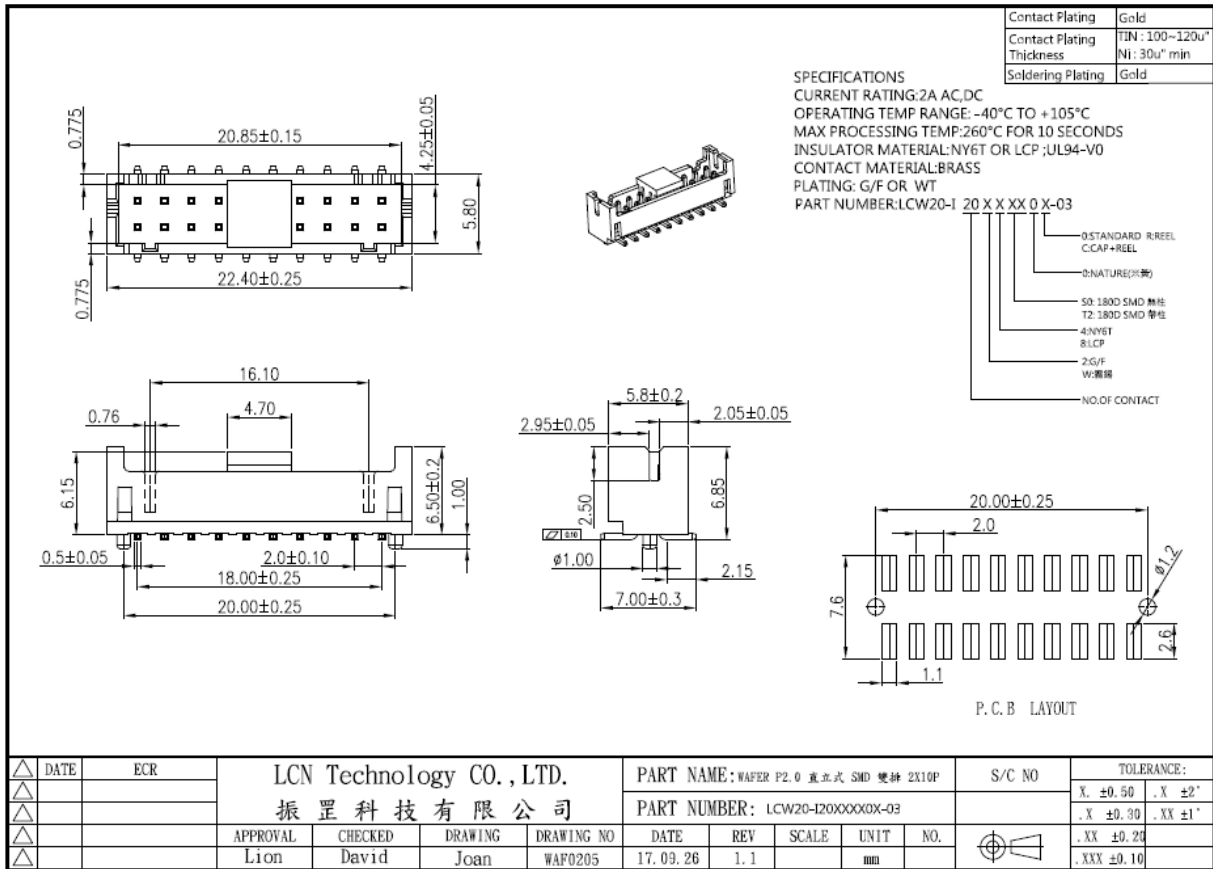

Figure 4: Wire to Board SMD 2\*10P Connector Drawing

Table 9: Wire to Board SMD 2\*10P Connector (CN1) Pin Define

Signal Name	Pin #	Pin #	Signal Name
NC	2	1	GND
P2_MDI0P_CN	4	3	P2_MDI1P_CN
P2_MDI0N_CN	6	5	P2_MDI1N_CN
P2_MDI2P_CN	8	7	P2_MDI3P_CN
P2_MDI2N_CN	10	9	P2_MDI3N_CN
P1_MDI0P_CN	12	11	P1_MDI1P_CN
P1_MDI0N_CN	14	13	P1_MDI1N_CN
P1_MDI2P_CN	16	15	P1_MDI3P_CN
P1_MDI2N_CN	18	17	P1_MDI3N_CN
NC	20	19	GND

**Table 10: 2X5 Pin Header (CN2) Pin Define**

Signal Name	Pin #	Pin #	Signal Name
3.3V_LANB	1	2	3.3_LANA
LANB_LINK_100_N	3	4	LANA_LINK_100_N
LANB_LINK_ACT_N	5	6	LANA_LINK_ACT_N
LANB_LINK_1000_N	7	8	LANA_LINK_1000_N
		10	GND

**Table 11: LAN LED Table**

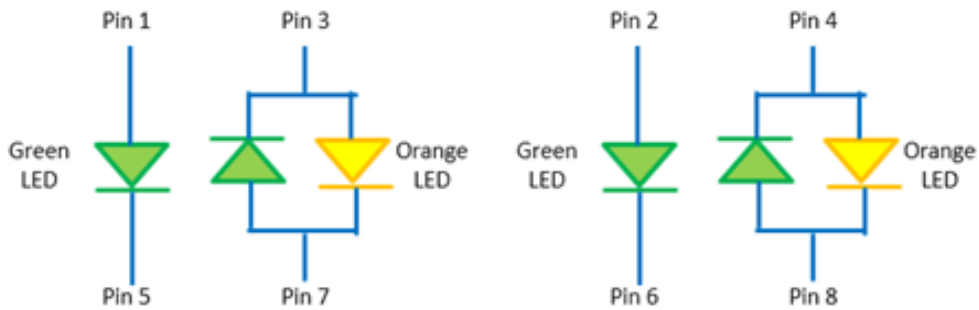

Speed LED	
10M	OFF
100M	OFF
1G	Orange
Link-Activity LED	
Link-up	Green
Tx/Rx Activity	Blinking Green



### 2.6.6. Packing List

- EGPL-G2N1 M.2 2280 Board x 1
- 20pin Pitch 2.0 Connector to 2 RJ45 Cable x 1

### 2.7. Software Support

- Windows: 10 (64bit)
- Linux (igc): kernel 5.x version

## 3. Installation Guide

Please download driver from Intel official website.

Or you can download Intel i225 chip driver from Intel official web site directly.

<https://www.intel.com/content/www/us/en/products/details/ethernet/gigabit-controllers/i225-controllers/downloads.html>

## 4. Appedix

innodisk

### 宜鼎國際股份有限公司 Innodisk Corporation REACH Declaration

Tel:(02)7703-3000 Fax:(02) 7703-3555 Internet: <https://www.innodisk.com/>

Innodisk Corporation pursues its social responsibility for global environmental preservation by committing to be compliant with REACH regulation (REGULATION (EC) No 1907/2006). We hereby confirm that the product(s),

**Scope: Flash Memory, DRAM Module and Embedded Peripherals Products.**

- The standard products of **not listed** in the Appendix2 meet the requirements of REACH SVHC regulations(SVHCs < 0.1% in Article), as described in the candidate list table currently including 224 substances and shown on the ECHA website. (<http://echa.europa.eu/de/candidate-list-table>).
- The standard products listed in the Appendix2 contain(s) one or more hazardous substances or constituents exceeding 0.1 % by weight in article if not otherwise specified in candidate list table.  
Where the threshold value is exceeded, the substances in question are to be declared in accompanying. (SVHCs > 0.1% in Article).
- Comply with REACH Annex XVII.

#### Guarantor

Company name 公司名稱： Innodisk Corporation 宜鼎國際股份有限公司

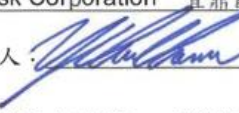
Company Representative 公司代表人：  陳怡全

Company Representative Title 公司代表人職稱： QA Manager 品保經理

Date 日期： 2022 / 06 / 14





## RoHS 自我宣告書 (RoHS Declaration of Conformity)

### Manufacturer Products: All Innodisk EM FLASH, DRAM and EP products

- 一、 宜鼎國際股份有限公司（以下稱本公司）特此保證售予貴公司之所有產品，皆符合歐盟 2011/65/EU 及 (EU) 2015/863 關於 RoHS 之規範要求。  
Innodisk Corporation declares that all products sold to the company, are complied with European Union RoHS Directive (2011/65/EU) and (EU) 2015/863 requirement.
- 二、 本公司同意因本保證書或與本保證書相關事宜有所爭議時，雙方宜友好協商，達成協議。  
Innodisk Corporation agrees that both parties shall settle any dispute arising from or in connection with this Declaration of Conformity by friendly negotiations.
- 三、 本公司聲明我們的產品符合 RoHS 指令的附件中 7(a)、7(c)-I、6(c) 允許豁免。  
We declare, our products permitted by the following exemptions specified in the Annex of the RoHS directive.
- ※ 7(a) Lead in high melting temperature type solders (i.e. lead-based alloys containing 85% by weight or more lead).
  - ※ 7(c)-I Electrical and electronic components containing lead in a glass or ceramic other than dielectric ceramic in capacitors, e.g. piezoelectric devices, or in a glass or ceramic matrix compound.
  - ※ 6(c) Copper alloy containing up to 4% lead by weight.  
(This exemption applies to products that use antennas)

Name of hazardous substance	Limited of RoHS ppm (mg/kg)
鉛 (Pb)	< 1000 ppm
汞 (Hg)	< 1000 ppm
鎘 (Cd)	< 100 ppm
六價鉻 (Cr 6+)	< 1000 ppm
多溴聯苯 (PBBs)	< 1000 ppm
多溴二苯醚 (PBDEs)	< 1000 ppm
鄰苯二甲酸二(2-乙基己基)酯 (DEHP)	< 1000 ppm
鄰苯二甲酸丁酯苯甲酯 (BBP)	< 1000 ppm
鄰苯二甲酸二丁酯 (DBP)	< 1000 ppm

宜鼎國際股份有限公司  
Innodisk Corporation

鄰苯二甲酸二異丁酯 (DIBP)

< 1000 ppm

立 保 證 書 人 (Guarantor)

Company name 公司名稱： Innodisk Corporation 宜鼎國際股份有限公司

Company Representative 公司代表人： Randy Chien 簡川勝

Company Representative Title 公司代表人職稱： Chairman 董事長

Date 日期： 2021 / 06 / 09



# Contact us

## Headquarters (Taiwan)

5F., No. 237, Sec. 1, Datong Rd., Xizhi Dist., New Taipei City 221, Taiwan

Tel: +886-2-77033000

Email: sales@innodisk.com

## Branch Offices:

### USA

usasales@innodisk.com

+1-510-770-9421

### Europe

eusales@innodisk.com

+31-40-3045-400

### Japan

jpsales@innodisk.com

+81-3-6667-0161

### China

sales\_cn@innodisk.com

+86-755-2167-3689

**[www.innodisk.com](http://www.innodisk.com)**

© 2021 Innodisk Corporation.

All right reserved. Specifications are subject to change without prior notice.

January 30, 2023