

EGPL-G2S2

M.2 2242 to dual isolated GbE LAN module

Customer:

Customer

Part Number:

Innodisk

Part Number:

Innodisk

Model Name:

Date:

Innodisk Approver	Customer Approver

Table of Contents

TABLE OF CONTENTS	I
REVISION HISTORY	II
LIST OF TABLES	1
LIST OF FIGURES	2
1. PRODUCT INTRODUCTION	3
1.1. OVERVIEW	3
1.2. FEATURES	3
2. PRODUCT SPECIFICATIONS	4
2.1. DEVICE PARAMETERS	4
2.2. ELECTRICAL SPECIFICATIONS.....	5
2.2.1.POWER REQUIREMENT.....	5
2.2.2.POWER CONSUMPTION	5
2.3. ENVIRONMENTAL SPECIFICATIONS	5
2.3.1.TEMPERATURE RANGES.....	5
2.3.2.HUMIDITY	5
2.3.3.SHOCK AND VIBRATION	5
2.3.4.MEAN TIME BETWEEN FAILURE (MTBF)	5
2.4. CE AND FCC COMPATIBILITY.....	6
2.5. ROHS COMPLIANCE	6
2.6. HARDWARE.....	7
2.6.1.LAYOUT	7
2.6.2.PIN DEFINE	8
2.6.3.I/O CONNECTOR MECHANICAL DRAWING & PIN DEFINES	9
2.6.4.EGPL-G2S2 MECHANICAL DRAWING	12
2.6.5.CABLE MECHANICAL DRAWING.....	13
2.6.6.PACKING LIST	13
2.7. SOFTWARE SUPPORT.....	14
3. INSTALLATION GUIDE	14
4. APPEDIX	14
CONTACT US	18

REVISION HISTORY

Revision	Description	Date
1.0	First Released	Sep, 2022

List of Tables

TABLE 1: DEVICE PARAMETERS	4
TABLE 2: POWER REQUIREMENT.....	5
TABLE 3: POWER CONSUMPTION	5
TABLE 4: TEMPERATURE RANGES.....	5
TABLE 5: SHOCK AND VIBRATION	5
TABLE 6: MEAN TIME BETWEEN FAILURE (MTBF).....	6
TABLE 7: M.2 2242 PCB LAYOUT LEGEND.....	7
TABLE 8: DAUGHTER BOARD PCB LAYOUT LEGEND	7
TABLE 9: M.2 B-M KEY PIN DEFINE.....	8
TABLE 10: WIRE TO BOARD SMD 2*10P CONNECTOR PIN DEFINE.....	9
TABLE 11: RJ45 LAN LED TABLE.....	11

List of Figures

FIGURE 1: BLOCK DIAGRAM	3
FIGURE 2: M.2 2242 BOARD PICTURE.....	4
FIGURE 3: MOUNTING HOLE DAUGHTER BOARD PICTURE	4
FIGURE 4: WIRE TO BOARD SMD 2*10P CONNECTOR DRAWING	9
FIGURE 5: RJ45 CONNECTOR DRAWING	10
FIGURE 6: EGPL-G2S2 M.2 BOARD DRAWING	12
FIGURE 7: MOUNTING HOLE DAUGHTER BOARD DRAWING.....	12
FIGURE 8: BOARD TO BOARD LAN CABLE DRAWING.....	13

1. Product Introduction

1.1. Overview

Innodisk EGPL-G2S2 is designed with M.2 2242 form factor with B/M key, EGPL-G2S2 supports PCIe Gen 2.1 with a single lane to dual isolated GbE LAN, optimized for higher performance and lower power, which brings you a flexible expansion solution for embedded systems.

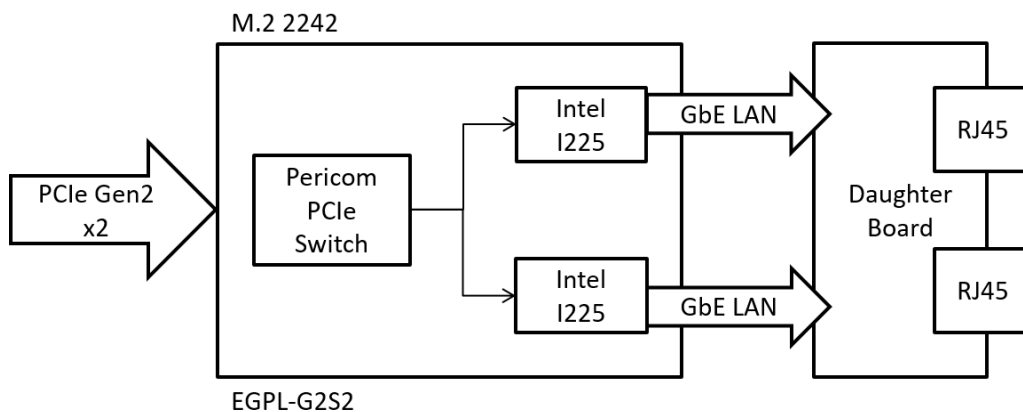

Figure 1: Block Diagram

1.2. Features

- Dual isolated GbE LAN ports
- Complies with EN61000-4-5 2kV surge protection
- Complies with IEC 60950-1:2005 + A1: 2009 + A2:2013 2kV HiPOT protection
- Complies with EN61000-4-2 (ESD) Air-15kV, Contact-8kV
- Flexible daughter board with cable to fit into different system
- Industrial temperature -40 °C to 85 °C
- 30μ" golden finger, 3-year warranty
- Industrial design, manufactured in Innodisk Taiwan

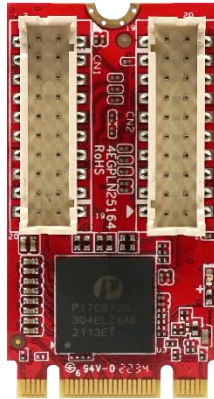

Figure 2: M.2 2242 Board Picture

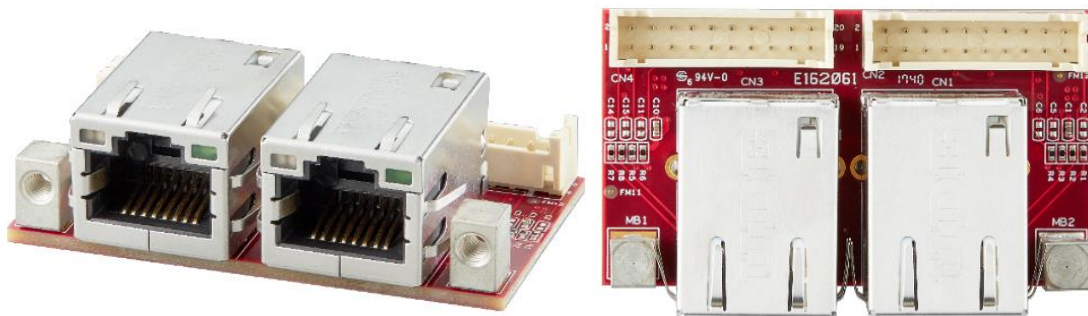

Figure 3: Mounting Hole Daughter Board Picture

2. Product Specifications

2.1. Device Parameters

Table 1: Device Parameters

Form Factor	M.2 2242 B-M
Input I/F	PCI Express 2.1 x 2
Output I/F	Dual GbE LAN
Output Connector	RJ45 x 2
Dimension (WxLxH)	Main board: 22 x 42 x 9.01 mm Daughter board: 28 x 50 x 19.37mm

2.2. Electrical Specifications

2.2.1. Power Requirement

Table 2: Power Requirement

Item	Connector	Rating
Input voltage	M.2 Golden Finger	+3.3 DC +-5%

2.2.2. Power Consumption

Table 3: Power Consumption

Voltage(V)	RMS(mA)	Max (mA)
3.3	704.5	759.5

2.3. Environmental Specifications

2.3.1. Temperature Ranges

Table 4: Temperature Ranges

Temperature	Range
Operating	Standard Grade: 0°C to +70°C Industrial Grade: -40°C to +85°C
Storage	-55°C to +95°C

2.3.2. Humidity

Relative Humidity: 10-95%, non-condensing

2.3.3. Shock and Vibration

Table 5: Shock and Vibration

Reliability	Test Conditions	Reference Standards
Vibration	7 Hz to 2K Hz, 20G, 3 axes	IEC 68-2-6
Mechanical Shock	Duration: 0.5ms, 1500 G, 3 axes	IEC 68-2-27

2.3.4. Mean Time between Failure (MTBF)

Reliability prediction methodology provides the basis for reliability evaluation and analysis. The purpose of the prediction is to predict the life time of the product in units of failure rate and MTBF.

Table 6: Mean Time between Failure (MTBF)

Product	Condition	MTBF (Hours)
EGPL-G202	The analysis is at 25°C ambient temperature by Telcordia SR-332, Issues 4, Method I, Case 3 under Ground Benign, Controlled environment, 50% operation stress	11,706,003

2.4. CE and FCC Compatibility

EGPL-G2S2 conforms to CE and FCC requirements.

2.5. RoHS Compliance

EGPL-G2S2 is fully compliant with RoHS directive.

2.6. Hardware

2.6.1. Layout

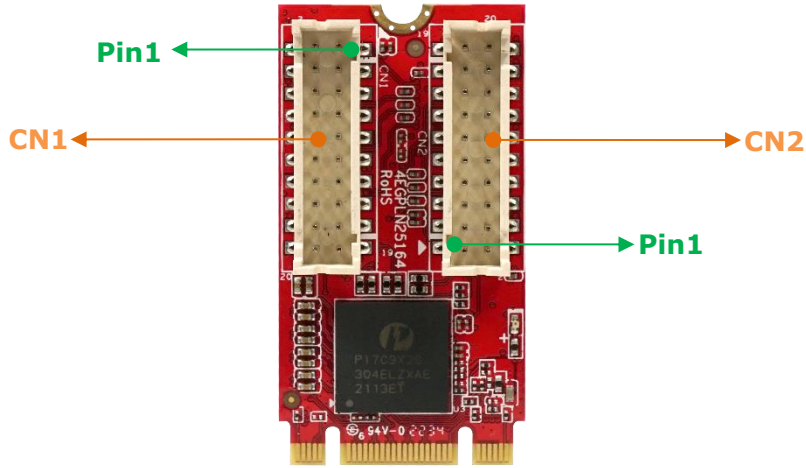

Table 7: M.2 2242 PCB Layout Legend

Label	Connector Type	Function
CN1,2	Wire to board SMD 2*10P 180° P:2.0mm H:4.0mm	GbE LAN Signal 10/100/1000 LED Signal



Table 8: Daughter Board PCB Layout Legend

Label	Connector Type	Function
CN1,3	10/100/1000 Base-T RJ45 DIP 10P8C 90° LED: Green-Orange/Green	GbE LAN Port 10/100/1000 LED Indicator
CN2,4	Wire to board SMD 2*10P 180° P:2.0mm H:6.5mm	GbE LAN Signal 10/100/1000 LED Signal

2.6.2. Pin Define

Table 9: M.2 B-M Key Pin Define

Signal Name	Pin #	Pin #	Signal Name
		75	GND
3.3V	74	73	GND
3.3V	72	71	GND
3.3V	70	69	NC
NC	68	67	NC
Module Key M			
NC	58		
NC	56	57	GND
PE_WAKE_N	54	55	CLK+
GND	52	53	CLK-
PE_RST	50	51	GND
NC	48	49	RX0+
NC	46	47	RX0-
NC	44	45	GND
NC	42	43	TX0+
NC	40	41	TX0-
NC	38	39	GND
NC	36	37	RX1+
NC	34	35	RX1-
NC	32	33	GND
NC	30	31	TX1+
NC	28	29	TX1-
NC	26	27	GND
NC	24	25	NC
NC	22	23	NC
NC	20	21	GND
Module Key B			
NC	10	11	NC
NC	8	9	NC
NC	6	7	NC
3.3V	4	5	NC
3.3V	2	3	GND
		1	GND

2.6.3. I/O Connector Mechanical Drawing & Pin Defines

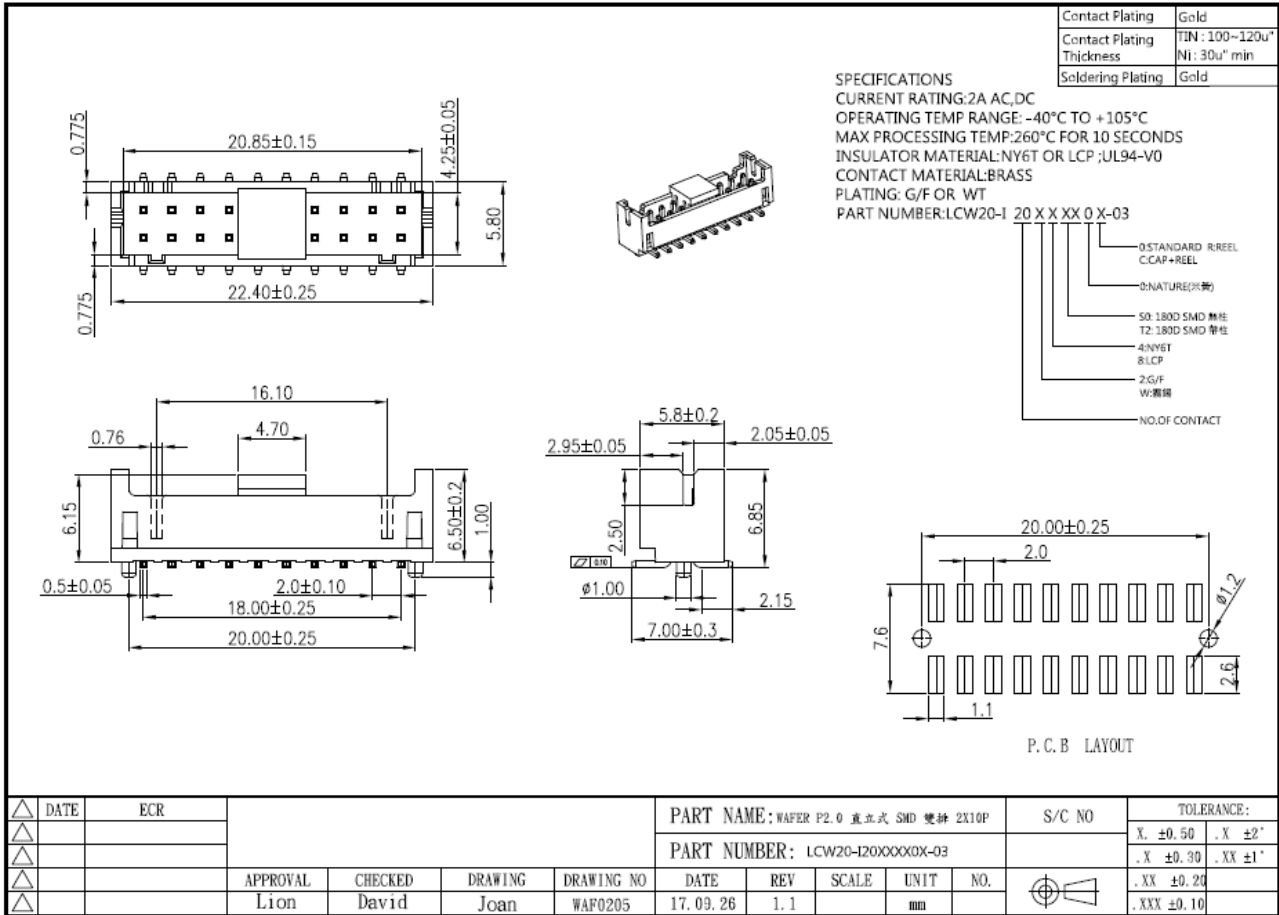

Figure 4: Wire to Board SMD 2*10P Connector Drawing

Table 10: Wire to Board SMD 2*10P Connector Pin Define

Signal Name	Pin #	Pin #	Signal Name
LINK_100_N	2	1	MDI0P_IC
LINK_ACT_N	4	3	MDI0N_IC
LINK_1000_N	6	5	MDI1P_IC
GND	8	7	MDI1N_IC
GND	10	9	MDI2P_IC
GND	12	11	MDI2N_IC
3.3V	14	13	MDI3P_IC
3.3V	16	15	MDI3N_IC
NC	18	17	NC
NC	20	19	NC

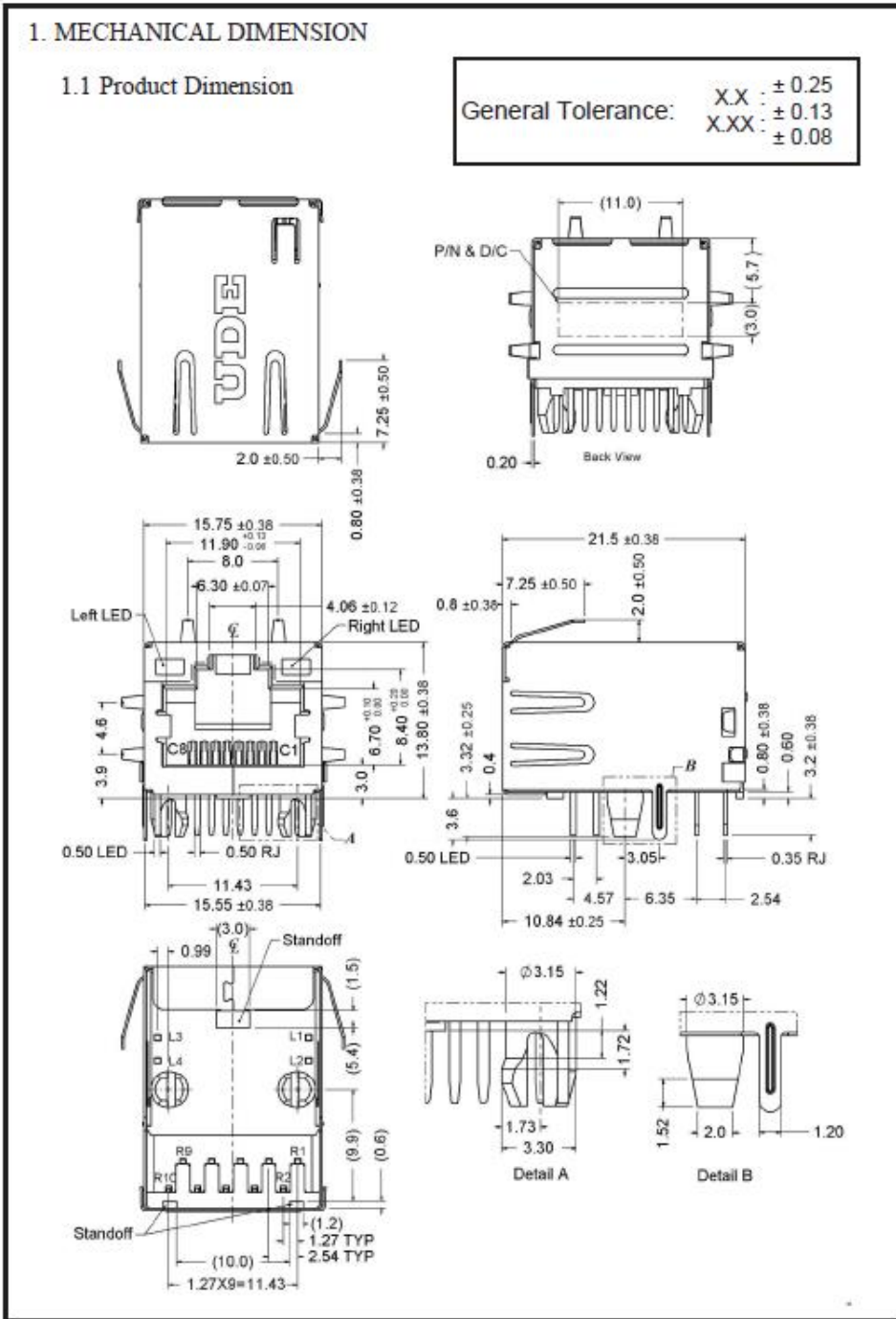
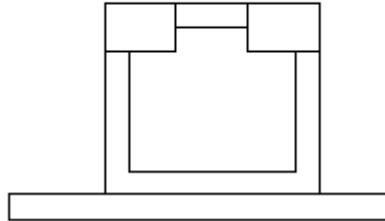

Figure 5: RJ45 Connector Drawing

Table 11: RJ45 LAN LED Table

Orange
/Green Green



Speed LED	
10M	OFF
100M	OFF
1G	Orange
Link-Activity LED	
Link-up	Green
Tx/Rx Activity	Blinking Green

2.6.4. EGPL-G2S2 Mechanical Drawing

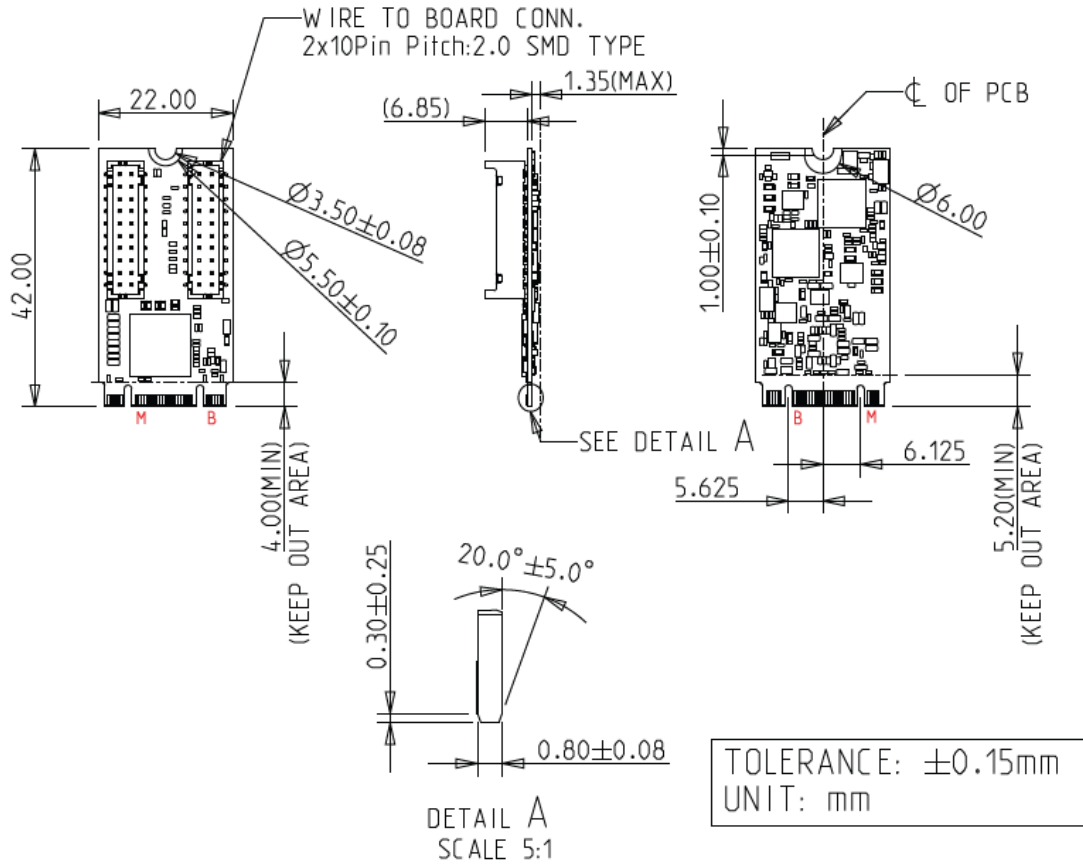

Figure 6: EGPL-G2S2 M.2 Board Drawing

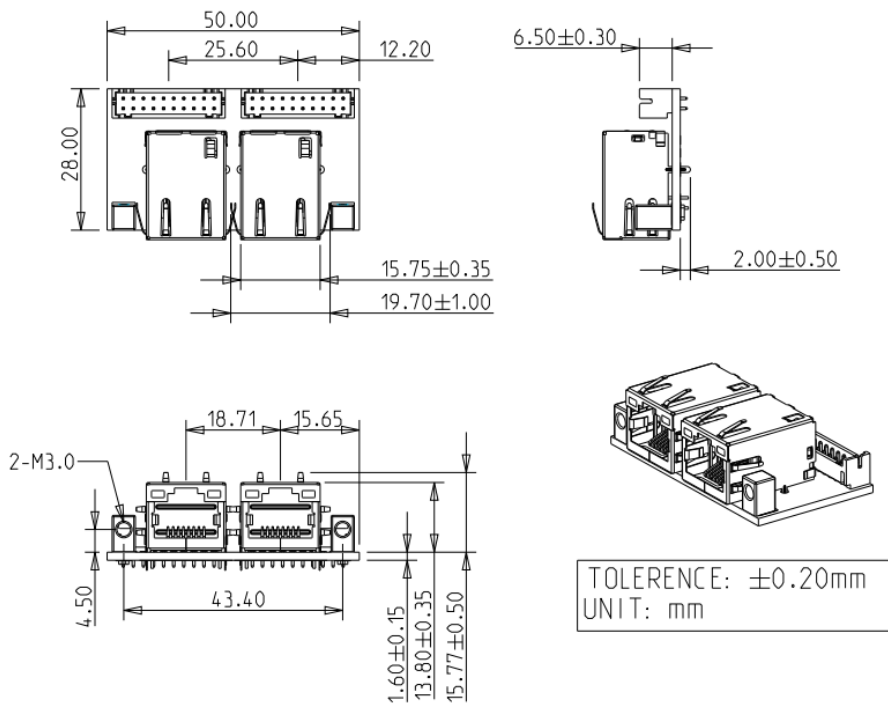

Figure 7: Mounting Hole Daughter Board Drawing

2.6.5. Cable Mechanical Drawing

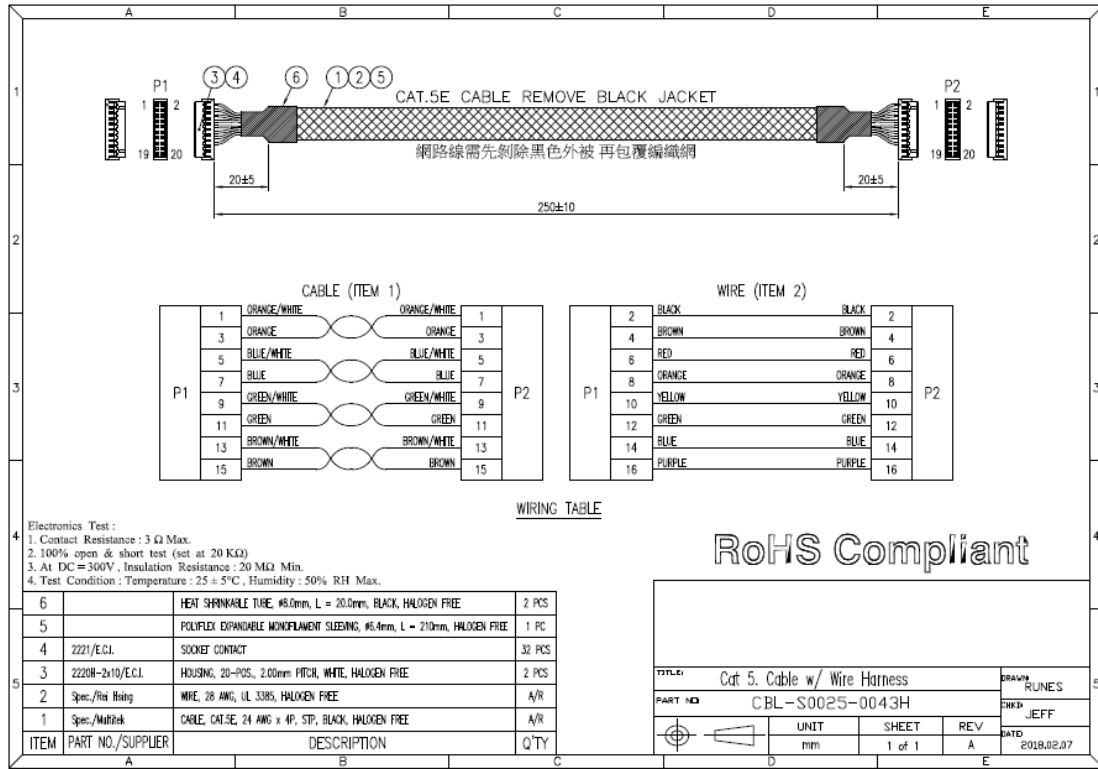

Figure 8: Board to Board LAN Cable Drawing

2.6.6. Packing List

- EGPL-G2S2 M.2 Board x 1
- EGPL-G2S2 Daughter Board x 1
- Board to Board LAN Cable x 2

2.7. Software Support

Foxville (I225/I226) Operating System Support Matrix:

Operating System / SW	I225 - x86, 64 bit	I226 – x86, 64 bit
Windows 7 / 8 / 8.1	No	
Windows 10 RS5+ / 10S	Yes	
Windows 11	Yes (From ADL, NetAdapterCX)	
Windows Server 2019/2022	Yes (LM/IT sku only)	
Mac OS	Yes (from OS Version 10.16.5)	Yes (from OS Version 12.3)
Linux	Yes (upstream kernel release – from 5.8)	Yes (upstream kernel release – from 5.16.18)
Linux RHEL	Yes RHEL 8.1 (LM/V sku) RHEL 8.3 (IT sku)	Yes RHEL 8.6 (LM/-V/-IT)
DPDK	Yes (from 20.05)	Yes (from 22.07)
FreeBSD	Yes	
Legacy PXE	Yes	Yes (UEFI PXE only)
UEFI 2.4	Yes	
Manufacturing / NVM Programing Tools	Supported on Windows, Linux, x86 Architecture only	

3. Installation Guide

Please download driver from Intel official website.

Or you can download Intel i225 chip driver from Intel official web site directly.

<https://www.intel.com/content/www/us/en/products/details/ethernet/gigabit-controllers/i225-controllers/downloads.html>

4. Appedix

innodisk

宜鼎國際股份有限公司
Innodisk Corporation
REACH Declaration

Tel:(02)7703-3000 Fax:(02) 7703-3555 Internet: <https://www.innodisk.com/>

Innodisk Corporation pursues its social responsibility for global environmental preservation by committing to be compliant with REACH regulation (REGULATION (EC) No 1907/2006). We hereby confirm that the product(s),

Scope: Flash Memory, DRAM Module and Embedded Peripherals Products.

- The standard products of **not listed in the Appendix2** meet the requirements of REACH SVHC regulations (SVHCs < 0.1% in Article), as described in the candidate list table currently including 224 substances and shown on the ECHA website. (<http://echa.europa.eu/de/candidate-list-table>).
- The standard products listed in the **Appendix2** contain(s) one or more hazardous substances or constituents exceeding 0.1 % by weight in article if not otherwise specified in candidate list table.
Where the threshold value is exceeded, the substances in question are to be declared in accompanying. (SVHCs > 0.1% in Article).
- Comply with REACH Annex XVII.

Guarantor

Company name 公司名稱： Innodisk Corporation 宜鼎國際股份有限公司

Company Representative 公司代表人：  陳怡全

Company Representative Title 公司代表人職稱： QA Manager 品保經理

Date 日期： 2022 / 06 / 14



RoHS 自我宣告書 (RoHS Declaration of Conformity)

Manufacturer Products: All Innodisk EM FLASH, DRAM and EP products

- 一、 宜鼎國際股份有限公司（以下稱本公司）特此保證售予貴公司之所有產品，皆符合歐盟 2011/65/EU 及 (EU) 2015/863 關於 RoHS 之規範要求。
Innodisk Corporation declares that all products sold to the company, are complied with European Union RoHS Directive (2011/65/EU) and (EU) 2015/863 requirement.
- 二、 本公司同意因本保證書或與本保證書相關事宜有所爭議時，雙方宜友好協商，達成協議。
Innodisk Corporation agrees that both parties shall settle any dispute arising from or in connection with this Declaration of Conformity by friendly negotiations.
- 三、 本公司聲明我們的產品符合 RoHS 指令的附件中 7(a)、7(c)-I、6(c) 允許豁免。
We declare, our products permitted by the following exemptions specified in the Annex of the RoHS directive.
- ※ 7(a) Lead in high melting temperature type solders (i.e. lead-based alloys containing 85% by weight or more lead).
 - ※ 7(c)-I Electrical and electronic components containing lead in a glass or ceramic other than dielectric ceramic in capacitors, e.g. piezoelectric devices, or in a glass or ceramic matrix compound.
 - ※ 6(c) Copper alloy containing up to 4% lead by weight.
(This exemption applies to products that use antennas)

Name of hazardous substance	Limited of RoHS ppm (mg/kg)
鉛 (Pb)	< 1000 ppm
汞 (Hg)	< 1000 ppm
鎘 (Cd)	< 100 ppm
六價鉻 (Cr 6+)	< 1000 ppm
多溴聯苯 (PBBs)	< 1000 ppm
多溴二苯醚 (PBDEs)	< 1000 ppm
鄰苯二甲酸二(2-乙基己基)酯 (DEHP)	< 1000 ppm
鄰苯二甲酸丁酯苯甲酯 (BBP)	< 1000 ppm
鄰苯二甲酸二丁酯 (DBP)	< 1000 ppm

宜鼎國際股份有限公司
Innodisk Corporation

鄰苯二甲酸二異丁酯 (DIBP)	< 1000 ppm
------------------	------------

立 保 證 書 人 (Guarantor)

Company name 公司名稱： Innodisk Corporation 宜鼎國際股份有限公司

Company Representative 公司代表人： Randy Chien 簡川勝

Company Representative Title 公司代表人職稱： Chairman 董事長

Date 日期： 2021 / 06 / 09



Contact us

Headquarters (Taiwan)

5F., No. 237, Sec. 1, Datong Rd., Xizhi Dist., New Taipei City 221, Taiwan

Tel: +886-2-77033000

Email: sales@innodisk.com

Branch Offices:

USA

usasales@innodisk.com

+1-510-770-9421

Europe

eusales@innodisk.com

+31-40-3045-400

Japan

jpsales@innodisk.com

+81-3-6667-0161

China

sales_cn@innodisk.com

+86-755-2167-3689

www.innodisk.com

© 2020 Innodisk Corporation.

All right reserved. Specifications are subject to change without prior notice.

November 3, 2023