

EMPL-G1S2

**mPCIe to single isolated GbE
LAN horizontal module**

Customer:

Customer

Part Number:

Innodisk

Part Number:

Innodisk

Model Name:

Date:

Innodisk	Customer
Approver	Approver

Table of Contents

TABLE OF CONTENTS	I
REVISION HISTORY	II
LIST OF TABLES	1
LIST OF FIGURES	2
1. PRODUCT INTRODUCTION	3
1.1. OVERVIEW	3
1.2. FEATURES	3
2. PRODUCT SPECIFICATIONS	5
2.1. DEVICE PARAMETERS	5
2.2. ELECTRICAL SPECIFICATIONS.....	5
2.2.1.POWER REQUIREMENT.....	5
2.2.2.POWER CONSUMPTION	5
2.3. ENVIRONMENTAL SPECIFICATIONS	6
2.3.1.TEMPERATURE RANGES.....	6
2.3.2.HUMIDITY	6
2.3.3.SHOCK AND VIBRATION	6
2.3.4.MEAN TIME BETWEEN FAILURE (MTBF)	6
2.4. CE AND FCC COMPATIBILITY.....	7
2.5. ROHS COMPLIANCE	7
2.6. HARDWARE.....	8
2.6.1.LAYOUT	8
2.6.2.PIN DEFINE	9
2.6.3.I/O CONNECTOR MECHANICAL DRAWING & PIN DEFINES	10
2.6.4.EMPL-G1S2 MECHANICAL DRAWING	13
2.6.5.CABLE MECHANICAL DRAWING.....	15
2.6.6.PACKING LIST	15
2.7. SOFTWARE SUPPORT.....	15
3. INSTALLATION GUIDE	16
4. APPEDIX	17
CONTACT US	20

REVISION HISTORY

Revision	Description	Date
1.0	First Released	Oct, 2022

List of Tables

TABLE 1: DEVICE PARAMETERS	5
TABLE 2: POWER REQUIREMENT.....	5
TABLE 3: POWER CONSUMPTION	5
TABLE 4: TEMPERATURE RANGES.....	6
TABLE 5: SHOCK AND VIBRATION	6
TABLE 6: MEAN TIME BETWEEN FAILURE (MTBF).....	6
TABLE 7: MPCIE PCB LAYOUT LEGEND.....	8
TABLE 8: DAUGHTER BOARD PCB LAYOUT LEGEND	8
TABLE 9: MPCIE PIN DEFINE	9
TABLE 10: WIRE TO BOARD SMD 1*13P CONNECTOR PIN DEFINE.....	10
TABLE 11: RJ45 LAN LED TABLE.....	12

List of Figures

FIGURE 1: BLOCK DIAGRAM	3
FIGURE 2: MPCIE BOARD PICTURE.....	4
FIGURE 3: MOUNTING HOLE DAUGHTER BOARD PICTURE (EMPL-G1S2-C1/W1)	4
FIGURE 4: BRACKET DAUGHTER BOARD PICTURE (EMPL-G1S2-C2/W2)	5
FIGURE 5: WIRE TO BOARD SMD 1*13P CONNECTOR DRAWING	10
FIGURE 6: RJ45 CONNECTOR DRAWING	11
FIGURE 7: EMPL-G1S2 MPCIE BOARD DRAWING	13
FIGURE 8: MOUNTING HOLE DAUGHTER BOARD DRAWING (EMPL-G1S2-C1/W1).....	13
FIGURE 9: BRACKET DAUGHTER BOARD DRAWING (EMPL-G1S2-C2/W2)	14
FIGURE 10: BRACKET DRAWING	14
FIGURE 11: BOARD TO BOARD LAN CABLE DRAWING.....	15

1. Product Introduction

1.1. Overview

Innodisk EMPL-G1S2 is designed with standard Mini PCI Express form factor, EMPL-G1S2 supports PCIe Gen 2.1 with a single lane to single independent isolated GbE LAN, optimized for higher performance and lower power, which brings you a flexible expansion solution for embedded systems.

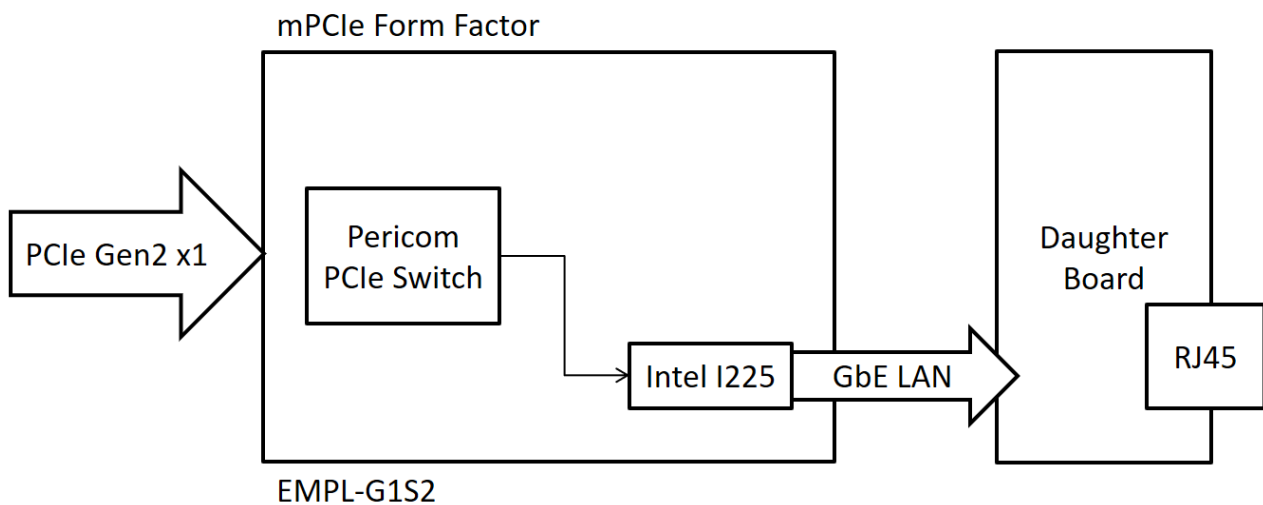

Figure 1: Block Diagram

1.2. Features

- Single isolated GbE LAN port
- Complies with EN61000-4-5 2kV Surge protection
- Complies with IEC 60950-1:2005 + A1: 2009 + A2:2013 2kV HiPOT protection
- Complies with EN61000-4-2 (ESD) Air-15kV, Contact-8kV
- Flexible daughter board with cable to fit into different system
- Optional terminal mounting hole or bracket for daughter board
- Optional Industrial Temperature (-40°C to +85°C) support
- 30μ " golden finger, 3 years warranty
- Industrial design, manufactured in Innodisk Taiwan

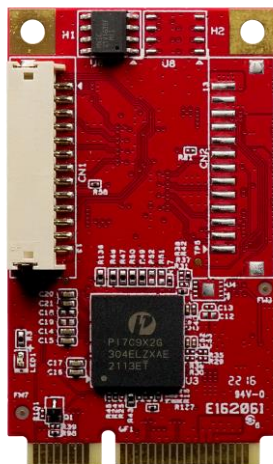

Figure 2: mPCIe Board Picture

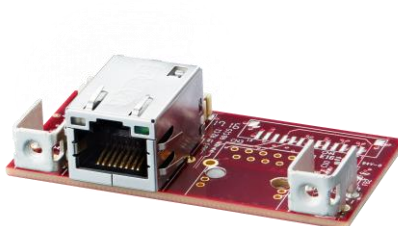

Figure 3: Mounting Hole Daughter Board Picture (EMPL-G1S2-C1/W1)



Figure 4: Bracket Daughter Board Picture (EMPL-G1S2-C2/W2)

2. Product Specifications

2.1. Device Parameters

Table 1: Device Parameters

Form Factor	mPCIe
Input I/F	PCI Express 2.1 x 1
Output I/F	Single GbE LAN
Output Connector	RJ45 x 1
Dimension (WxLxH)	30 x 50.95 x 6.15 mm

2.2. Electrical Specifications

2.2.1. Power Requirement

Table 2: Power Requirement

Item	Connector	Rating
Input voltage	mPCIe Golden Finger	+3.3 DC +-5%

2.2.2. Power Consumption

Table 3: Power Consumption

Voltage(V)	RMS(mA)	Max (mA)
3.3	485.75	508.62

2.3. Environmental Specifications

2.3.1. Temperature Ranges

Table 4: Temperature Ranges

Temperature	Range
Operating	Standard Grade: 0°C to +70°C Industrial Grade: -40°C to +85°
Storage	-55°C to +95°

2.3.2. Humidity

Relative Humidity: 10-95%, non-condensing

2.3.3. Shock and Vibration

Table 5: Shock and Vibration

Reliability	Test Conditions	Reference Standards
Vibration	7 Hz to 2K Hz, 20G, 3 axes	IEC 68-2-6
Mechanical Shock	Duration: 0.5ms, 1500 G, 3 axes	IEC 68-2-27

2.3.4. Mean Time between Failure (MTBF)

Reliability prediction methodology provides the basis for reliability evaluation and analysis. The purpose of the prediction is to predict the life time of the product in units of failure rate and MTBF.

Table 6: Mean Time between Failure (MTBF)

Product	Condition	MTBF (Hours)
EMPL-G1S2-C1/W1	The analysis is at 25°C ambient temperature by Telcordia SR-332, Issues 4, Method I, Case 3 under Ground Benign, Controlled environment, 50% operation stress	11,625,256
EMPL-G1S2-C2/W2	The analysis is at 25°C ambient temperature by Telcordia SR-332, Issues 4, Method I, Case 3 under Ground Benign, Controlled environment, 50% operation stress	11,943,218

2.4. CE and FCC Compatibility

EMPL-G1S2 conforms to CE and FCC requirements.

2.5. RoHS Compliance

EMPL-G1S2 is fully compliant with RoHS directive.

2.6. Hardware

2.6.1. Layout

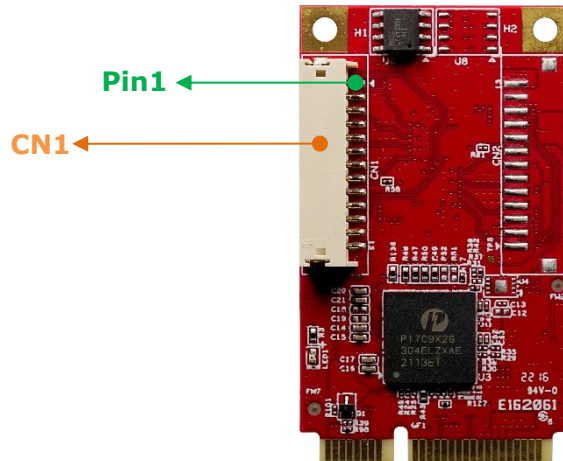

Table 7: mPCIe PCB Layout Legend

Label	Connector Type	Function
CN1	Wire to board SMD 1*13P 90° P:1.5mm	GbE LAN Signal 10/100/1000 LED Signal

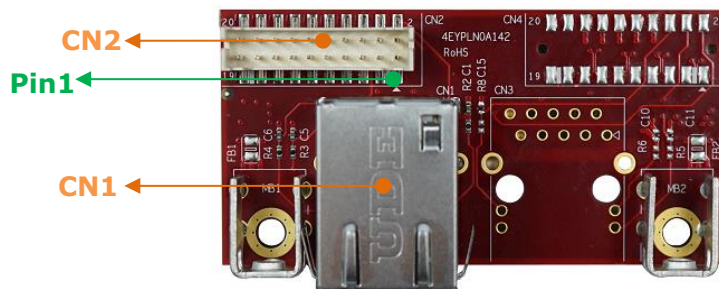

Table 8: Daughter Board PCB Layout Legend

Label	Connector Type	Function
CN1	10/100/1000 Base-T RJ45 DIP 10P8C 90° LED: Green-Orange/Green	GbE LAN Port 10/100/1000 LED Indicator
CN2	Wire to board SMD 1*13P 90° P:1.5mm	GbE LAN Signal 10/100/1000 LED Signal

2.6.2. Pin Define

Table 9: mPCIe Pin Define

Signal Name	Pin #	Pin #	Signal Name
NC	51	52	3.3V AUX
NC	49	50	GND
NC	47	48	NC
NC	45	46	NC
GND	43	44	NC
3.3V AUX	41	42	NC
3.3V AUX	39	40	GND
GND	37	38	NC
GND	35	36	NC
RX+	33	34	GND
RX-	31	32	SMBDATA
GND	29	30	SMBCLK
GND	27	28	NC
TX+	25	26	GND
TX-	23	24	3.3V AUX
GND	21	22	PERST#
NC	19	20	NC
NC	17	18	GND
GND	15	16	NC
CLK+	13	14	NC
CLK-	11	12	NC
GND	9	10	NC
GND	7	8	NC
NC	5	6	NC
NC	3	4	GND
PE_WAKE_N	1	2	3.3V AUX

2.6.3. I/O Connector Mechanical Drawing & Pin Defines

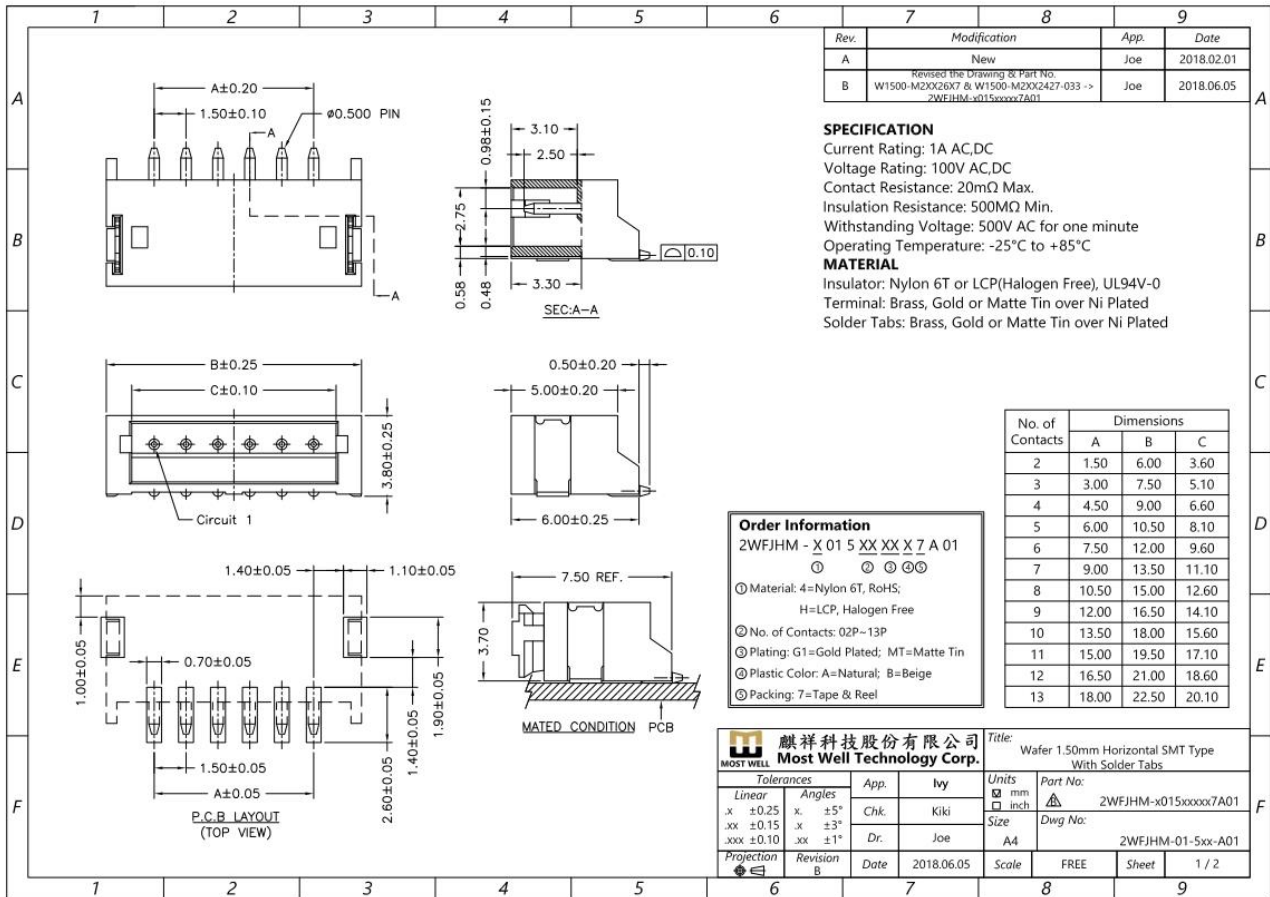

Figure 5: Wire to Board SMD 1*13P Connector Drawing

Table 10: Wire to Board SMD 1*13P Connector Pin Define

Pin #	Signal Name
1	MDI0P_IC
2	MDI0N_IC
3	MDI1P_IC
4	MDI1N_IC
5	MDI2P_IC
6	MDI2N_IC
7	MDI3P_IC
8	MDI3N_IC

9	B_SPEED_2500#
10	B_LINK_ACT_N
11	B_SPEED_1000#
12	GND
13	3.3V

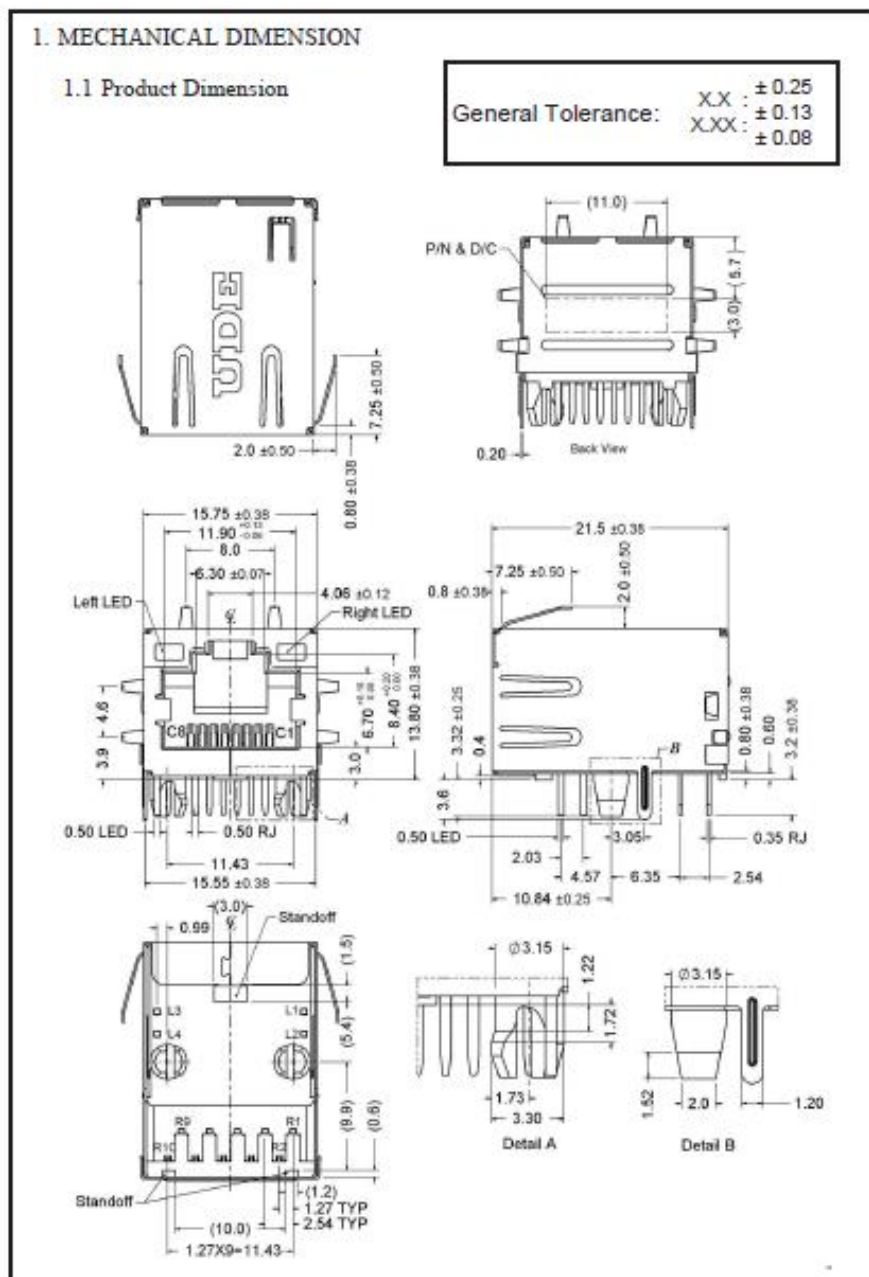
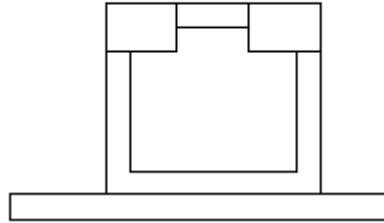

Figure 6: RJ45 Connector Drawing

Table 11: RJ45 LAN LED Table

Orange
/Green Green



Speed LED	
10M	OFF
100M	OFF
1G	Orange
Link-Activity LED	
Link-up	Green
Tx/Rx Activity	Blinking Green

2.6.4. EMPL-G1S2 Mechanical Drawing

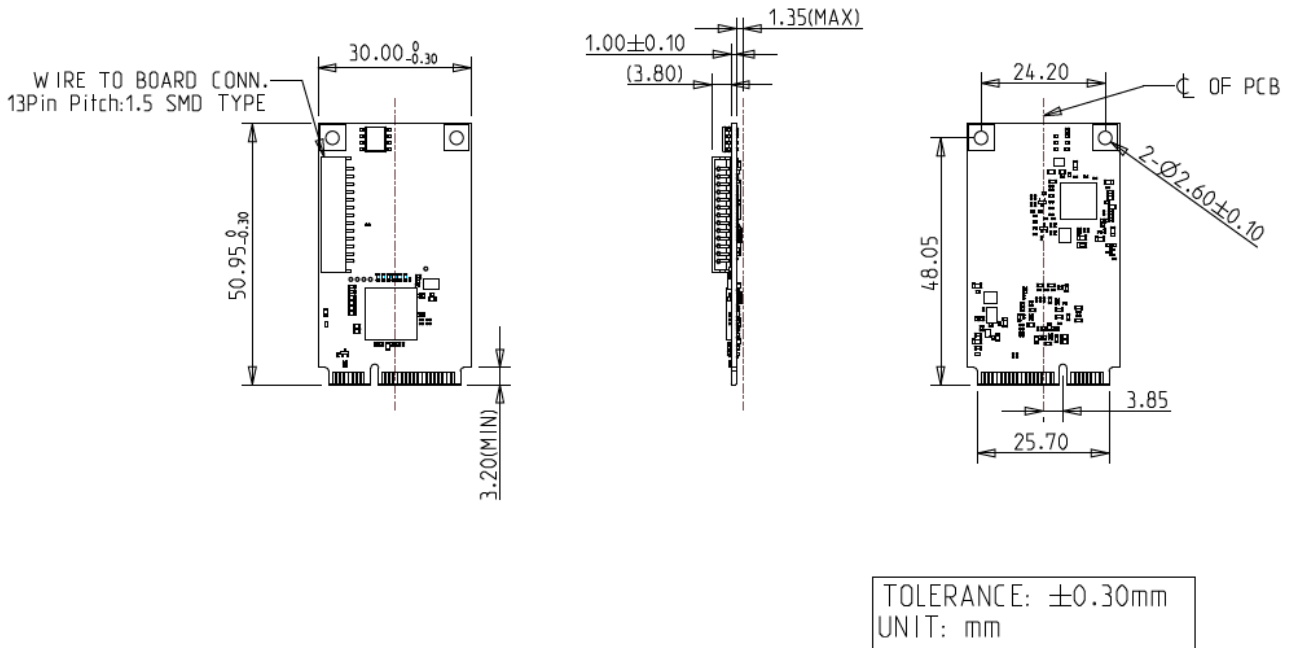

Figure 7: EMPL-G1S2 mPCIe Board Drawing

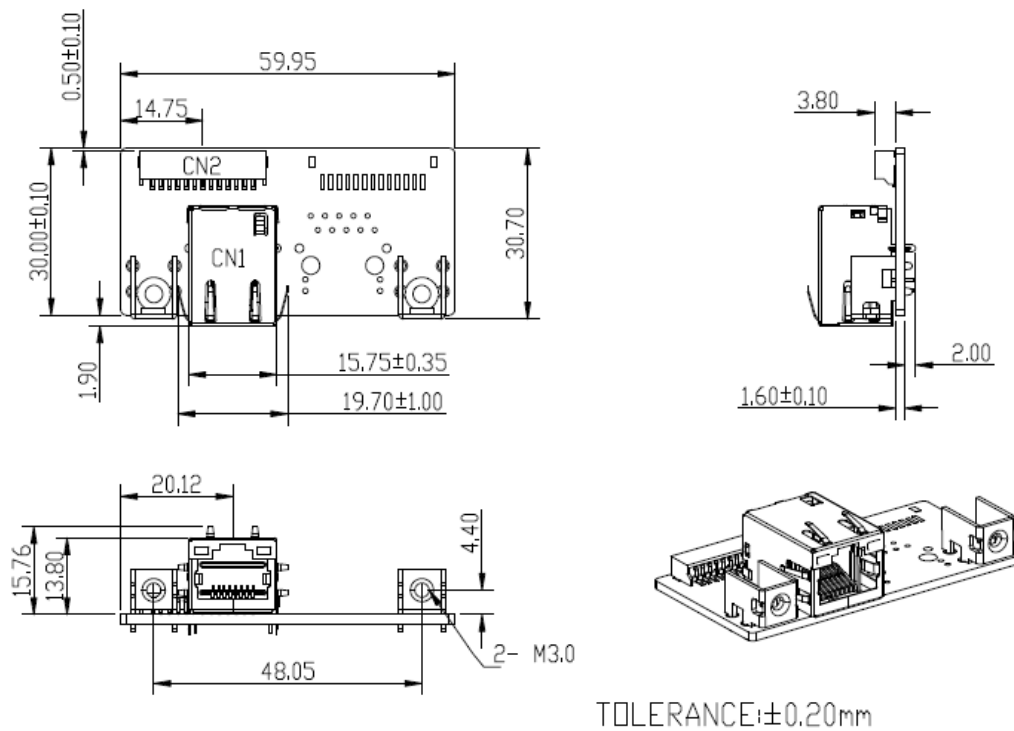

Figure 8: Mounting Hole Daughter Board Drawing (EMPL-G1S2-C1/W1)

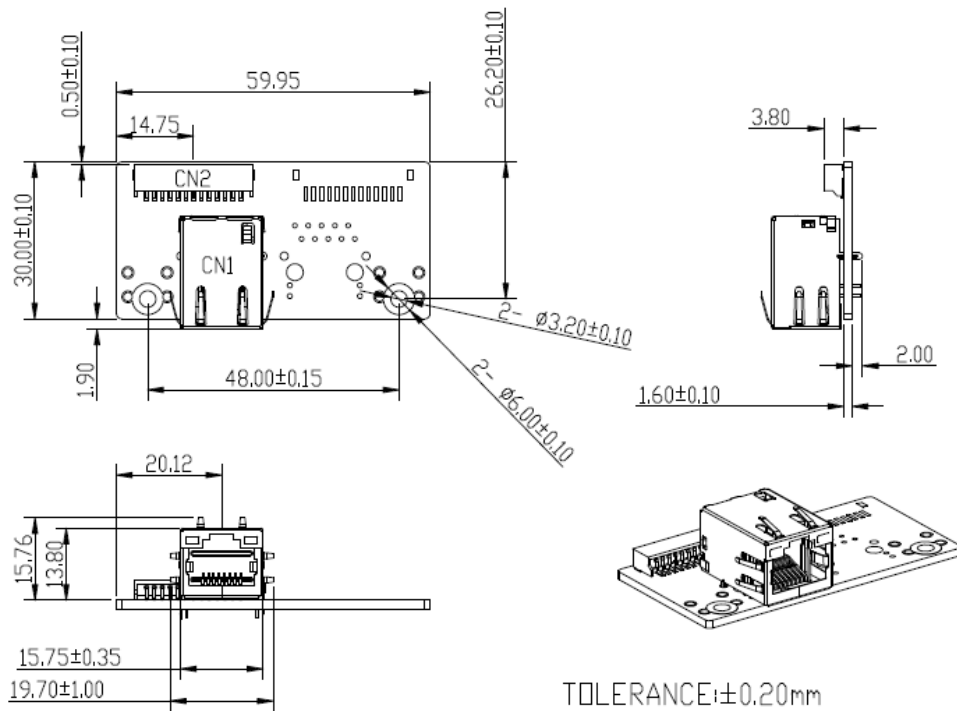

Figure 9: Bracket Daughter Board Drawing (EMPL-G1S2-C2/W2)

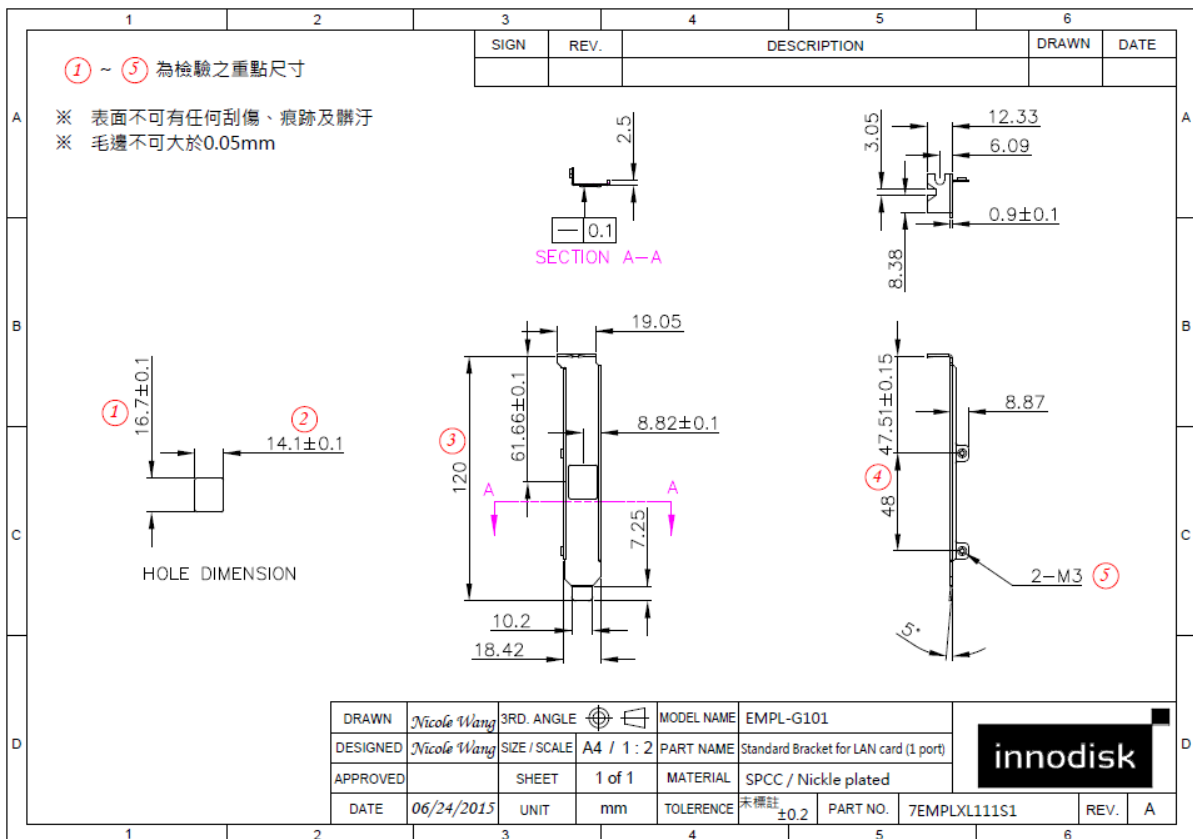

Figure 10: Bracket Drawing

2.6.5. Cable Mechanical Drawing

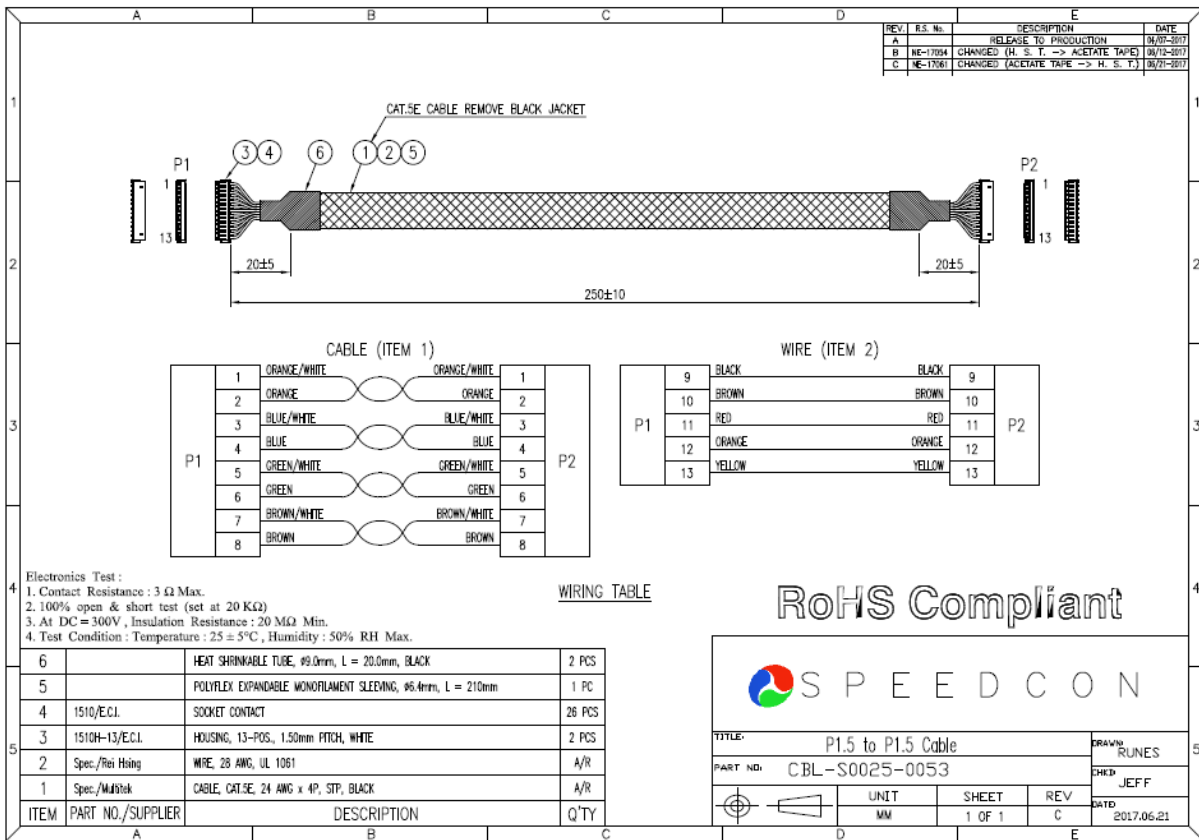

Figure 11: Board to Board LAN Cable Drawing

2.6.6. Packing List

- EMPL-G1S2 mPCIe Board x 1
- EMPL-G1S2 Daughter Board x 1
- Board to Board LAN Cable x 1
- Bracket x 1 (EMPL-G1S2-C2/W2 only)
- Screw M3*5 Silver x 2 (EMPL-G1S2 C2/W2 only)

2.7. Software Support

- Windows: 10(64bit)
- Linux (igc): kernel 5.x version

3. Installation Guide

Please download driver from Myinnodisk web site.

<https://myinnodisk.innodisk.com/myinnodisk/Login.aspx>

Or you can download Intel i225 chip driver from Intel official web site directly.

<https://www.intel.com/content/www/us/en/products/details/ethernet/gigabit-controllers/i225-controllers/downloads.html>

4. Appedix

innodisk

宜鼎國際股份有限公司 Innodisk Corporation REACH Declaration

Tel: (02) 7703-3000 Fax: (02) 7703-3555 Internet: <https://www.innodisk.com/>

Innodisk Corporation pursues its social responsibility for global environmental preservation by committing to be compliant with REACH regulation (REGULATION (EC) No 1907/2006). We hereby confirm that the product(s),

Scope: Flash Memory, DRAM Module and Embedded Peripherals Products.

- The standard products of **not listed in the Appendix2** meet the requirements of REACH SVHC regulations (SVHCs < 0.1% in Article), as described in the candidate list table currently including 224 substances and shown on the ECHA website. (<http://echa.europa.eu/de/candidate-list-table>).
- The standard products listed in the **Appendix2** contain(s) one or more hazardous substances or constituents exceeding 0.1 % by weight in article if not otherwise specified in candidate list table.
Where the threshold value is exceeded, the substances in question are to be declared in accompanying. (SVHCs > 0.1% in Article).
- Comply with REACH Annex XVII.

Guarantor

Company name 公司名稱： Innodisk Corporation 宜鼎國際股份有限公司

Company Representative 公司代表人：  陳怡全

Company Representative Title 公司代表人職稱： QA Manager 品保經理

Date 日期： 2022 / 06 / 14



RoHS 自我宣告書 (RoHS Declaration of Conformity)

Manufacturer Products: All Innodisk EM FLASH, DRAM and EP products

- 一、 宜鼎國際股份有限公司（以下稱本公司）特此保證售予貴公司之所有產品，皆符合歐盟 2011/65/EU 及 (EU) 2015/863 關於 RoHS 之規範要求。
Innodisk Corporation declares that all products sold to the company, are complied with European Union RoHS Directive (2011/65/EU) and (EU) 2015/863 requirement.
- 二、 本公司同意因本保證書或與本保證書相關事宜有所爭議時，雙方宜友好協商，達成協議。
Innodisk Corporation agrees that both parties shall settle any dispute arising from or in connection with this Declaration of Conformity by friendly negotiations.
- 三、 本公司聲明我們的產品符合 RoHS 指令的附件中 7(a)、7(c)-I、6(c) 允許豁免。
We declare, our products permitted by the following exemptions specified in the Annex of the RoHS directive.
- ※ 7(a) Lead in high melting temperature type solders (i.e. lead-based alloys containing 85% by weight or more lead).
 - ※ 7(c)-I Electrical and electronic components containing lead in a glass or ceramic other than dielectric ceramic in capacitors, e.g. piezoelectric devices, or in a glass or ceramic matrix compound.
 - ※ 6(c) Copper alloy containing up to 4% lead by weight.
(This exemption applies to products that use antennas)

Name of hazardous substance	Limited of RoHS ppm (mg/kg)
鉛 (Pb)	< 1000 ppm
汞 (Hg)	< 1000 ppm
鎘 (Cd)	< 100 ppm
六價鉻 (Cr 6+)	< 1000 ppm
多溴聯苯 (PBBs)	< 1000 ppm
多溴二苯醚 (PBDEs)	< 1000 ppm
鄰苯二甲酸二(2-乙基己基)酯 (DEHP)	< 1000 ppm
鄰苯二甲酸丁酯苯甲酯 (BBP)	< 1000 ppm
鄰苯二甲酸二丁酯 (DBP)	< 1000 ppm

宜鼎國際股份有限公司
Innodisk Corporation

鄰苯二甲酸二異丁酯 (DIBP)	< 1000 ppm
------------------	------------

立 保 證 書 人 (Guarantor)

Company name 公司名稱： Innodisk Corporation 宜鼎國際股份有限公司

Company Representative 公司代表人： Randy Chien 簡川勝

Company Representative Title 公司代表人職稱： Chairman 董事長

Date 日期： 2021 / 06 / 09



Contact us

Headquarters (Taiwan)

5F., No. 237, Sec. 1, Datong Rd., Xizhi Dist., New Taipei City 221, Taiwan

Tel: +886-2-77033000

Email: sales@innodisk.com

Branch Offices:

USA

usasales@innodisk.com

+1-510-770-9421

Europe

eusales@innodisk.com

+31-40-3045-400

Japan

jpsales@innodisk.com

+81-3-6667-0161

China

sales_cn@innodisk.com

+86-755-2167-3689

www.innodisk.com

© 2022 Innodisk Corporation.

All right reserved. Specifications are subject to change without prior notice.

October 18, 2022