

M.2 (S80)

3IE7 Series

Ultra iSLC

Customer: _____

Customer

Part

Number: _____

Innodisk

Part

Number: _____

Innodisk

Model Name: _____

Date: _____

Innodisk Approver	Customer Approver

**Total Solution For
Industrial Flash Storage**

Features:

- SATA III
- Kioxia 3D TLC NAND
- M.2 2280-D2-B-M
- Standard & Wide-temperature
- Support Ultra iSLC technology
- iPower Guard
- iData Guard
- Dynamic Thermal Management
- Hybrid Write

Performance:

- Sequential Read up to 560 MB/s
- Sequential Write up to 500 MB/s

Power Requirements:

Input Voltage:	3.3V±5%
Max Operating Wattage:	1.5W
Idle Wattage:	0.8W

Reliability:

Capacity	TBW	DWPD
40GB	2500	34.2
80GB	5000	34.2
160GB	10000	34.2
320GB	20000	34.2
640GB	40000	34.2

Data Retention	10 Years
Warranty	5 Years

For warranty details, please refer to:

https://www.innodisk.com/en/support_and_service/warranty

Table of contents

- LIST OF FIGURES7**
- 1. PRODUCT OVERVIEW8**
 - 1.1 INTRODUCTION OF INNODISK M.2 (S80) 3IE78**
 - 1.2 PRODUCT VIEW AND MODELS8**
 - 1.3 SATA INTERFACE.....8**
- 2. PRODUCT SPECIFICATIONS9**
 - 2.1 CAPACITY AND DEVICE PARAMETERS.....9**
 - 2.2 PERFORMANCE9**
 - 2.3 ELECTRICAL SPECIFICATIONS9**
 - 2.3.1 Power Requirement9*
 - 2.3.2 Power Consumption10*
 - 2.4 ENVIRONMENTAL SPECIFICATIONS10**
 - 2.4.1 Temperature Ranges10*
 - 2.4.2 Humidity10*
 - 2.4.3 Shock and Vibration10*
 - 2.4.4 Mean Time between Failures (MTBF)10*
 - 2.5 CE AND FCC COMPATIBILITY11**
 - 2.6 RoHS COMPLIANCE11**
 - 2.7 RELIABILITY11**
 - 2.8 TRANSFER MODE11**
 - 2.9 PIN ASSIGNMENT12**
 - 2.10 MECHANICAL DIMENSIONS.....14**
 - 2.11 ASSEMBLY WEIGHT14**
 - 2.12 SEEK TIME14**
 - 2.13 HOT PLUG.....14**
 - 2.14 NAND FLASH MEMORY.....14**
- 3. THEORY OF OPERATION15**
 - 3.1 OVERVIEW.....15**
 - 3.2 SATA III CONTROLLER15**
 - 3.3 ERROR DETECTION AND CORRECTION.....15**
 - 3.4 WEAR-LEVELING16**
 - 3.5 BAD BLOCKS MANAGEMENT16**
 - 3.6 iDATA GUARD.....16**
 - 3.7 GARBAGE COLLECTION.....16**
 - 3.8 TRIM16**
 - 3.9 iPOWER GUARD.....17**
 - 3.10 DIE RAID17**

- 3.11 THERMAL THROTTLING..... 17**
- 4. INSTALLATION REQUIREMENTS18**
 - 4.1 M.2 (S80) 3IE7 PIN DIRECTIONS 18**
 - 4.2 ELECTRICAL CONNECTIONS FOR M.2 (S80) 3IE7 18**
 - 4.3 DEVICE DRIVE 18**
- 5. SMART FEATURE SET19**
 - 5.1 SMART ATTRIBUTES..... 19**
- 6. PART NUMBER RULE21**

REVISION HISTORY

Revision	Description	Date
1.0	First released	Nov, 2023
1.1	Rename the series to Ultra iSLC	Dec., 2023
1.2	Update Warranty Period	Jan., 2024

List of Tables

TABLE 1: DEVICE PARAMETERS.....9

TABLE 2: PERFORMANCE (INNODISK 112-LAYER).....9

TABLE 3: INNODISK M.2 (S80) 3IE7 POWER REQUIREMENT.....9

TABLE 4: POWER CONSUMPTION.....10

TABLE 5: TEMPERATURE RANGE FOR M.2 (S80) 3IE7.....10

TABLE 6: SHOCK/VIBRATION TESTING FOR M.2 (S80) 3IE7.....10

TABLE 7: M.2 (S80) 3IE7 MTBF.....10

TABLE 8: M.2 (S80) 3IE7 TBW.....11

TABLE 9: INNODISK M.2 (S80) 3IE7 PIN ASSIGNMENT.....12

TABLE 10: SMART COMMAND.....19

TABLE 11: SMART ATTRIBUTE.....19

List of Figures

FIGURE 1: INNODISK M.2 (S80) 3IE7 (TYPE 2280).....8
FIGURE 2: INNODISK M.2 (S80) 3IE7 DIAGRAM (BGA) 14
FIGURE 3: INNODISK M.2 (S80) 3IE7 BLOCK DIAGRAM..... 15
FIGURE 4: SIGNAL SEGMENT AND POWER SEGMENT..... 18

1. Product Overview

1.1 Introduction of Innodisk M.2 (S80) 3IE7

Innodisk M.2 (S80) 3IE7 is characterized by L³ architecture with the latest SATA III (6.0GHz) NAND controller. Innodisk's exclusive L³ architecture is L² architecture multiplied LDPC (Low Density Parity Check). L² (Long Life) architecture is a 4K mapping algorithm that reduces WAF and features a real-time wear leveling algorithm to provide high performance and prolong lifespan with exceptional reliability. Innodisk M.2 (S80) 3IE7 is designed for industrial field, and supports several standard features, including TRIM, NCQ, and S.M.A.R.T. In addition, Innodisk's exclusive industrial-oriented firmware provides a flexible customization service, making it perfect for a variety of industrial applications.

CAUTION *TRIM must be enabled.*

TRIM enables SSD's controller to skip invalid data instead of moving. It can free up significant amount of resources, extends the lifespan of SSD by reducing erase, and write cycles on the SSD. Innodisk's handling of garbage collection along with TRIM command improves write performance on SSDs.

1.2 Product View and Models

Innodisk M.2 (S80) 3IE7 is available in following capacities.

M.2 (S80) 3IE7 40GB

M.2 (S80) 3IE7 80GB

M.2 (S80) 3IE7 160GB

M.2 (S80) 3IE7 320GB

M.2 (S80) 3IE7 640GB



Figure 1: Innodisk M.2 (S80) 3IE7 (type 2280)

1.3 SATA Interface

Innodisk M.2 (S80) 3IE7 supports SATA III interface, and compliant with SATA I and SATA II. SATA III interface can work with Serial Attached SCSI (SAS) host system, which is used in server computer. Innodisk M.2 (S80) 3IE7 is compliant with Serial ATA Gen 1, Gen 2 and Gen 3 specification (Gen 3 supports 1.5Gbps /3.0Gbps/6.0Gbps data rate).

2. Product Specifications

2.1 Capacity and Device Parameters

M.2 (S80) 3IE7 device parameters are shown in Table 1.

Table 1: Device parameters

Capacity	Cylinders	Heads	Sectors	LBA	User Capacity(MB)
40GB	16383	16	63	78161328	38165
80GB	16383	16	63	156301488	76319
160GB	16383	16	63	312581808	152628
320GB	16383	16	63	625142448	305245
640GB	16383	16	63	1250263728	610480

2.2 Performance

Burst Transfer Rate: 6.0Gbps

Table 2: Performance (innodisk 112-layer)

Capacity	Unit	40GB	80GB	160GB	320GB	640GB
Sequential ** Read (Q32T1)	MB/s	440	550	560	550	550
Sequential ** Write (Q32T1)		290	480	500	490	470
4KB Random*** Read (Q32T1)	IOPS	43,000	81,000	79,000	87,000	87,000
4KB Random*** Write (Q32T1)		59,000	75,000	57,000	75,000	75,000

Note: ** Performance results are based on CrystalDiskMark 6.0.2 with file size 1000MB.

Note: *** Performance results are based on Queue Depth 32

2.3 Electrical Specifications

2.3.1 Power Requirement

Table 3: Innodisk M.2 (S80) 3IE7 Power Requirement

Item	Symbol	Rating	Unit
Input voltage	V _{IN}	+3.3 DC +- 5%	V

2.3.2 Power Consumption

Table 4: Power Consumption

Mode	Power Consumption (W)
Read (RMS)	1.5
Write (RMS)	1.5
Idle (RMS)	0.8
Peak	3.5

Target: M.2 (S80) 3IE7 640GB

2.4 Environmental Specifications

2.4.1 Temperature Ranges

Table 5: Temperature range for M.2 (S80) 3IE7

Temperature	Range
Operating	Standard Grade: 0°C to +70°C
	Industrial Grade: -40°C to +85°C
Storage	-40°C to +85°C

2.4.2 Humidity

Relative Humidity: 10-95%, non-condensing

2.4.3 Shock and Vibration

Table 6: Shock/Vibration Testing for M.2 (S80) 3IE7

Reliability	Test Conditions	Reference Standards
Vibration	7 Hz to 2K Hz, 20G, 3 axes	IEC 60068-2-6
Mechanical Shock	Duration: 0.5ms, 1500 G, 3 axes	IEC 60068-2-27

2.4.4 Mean Time between Failures (MTBF)

The following table summarizes the MTBF prediction results for various M.2 (S80) 3IE7 configurations. The analysis was performed using a RAM Commander™ failure rate prediction.

- **Failure Rate:** The total number of failures within an item population, divided by the total number of life units expended by that population, during a particular measurement interval under stated condition.
- **Mean Time between Failures (MTBF):** A basic measure of reliability for repairable items: The mean number of life units during which all parts of the item perform within their specified limits, during a particular measurement interval under stated conditions.

Table 7: M.2 (S80) 3IE7 MTBF

Product	Condition	MTBF (Hours)
Innodisk M.2 (S80) 3IE7	Telcordia SR-332 GB, 25°C	>3,000,000

2.5 CE and FCC Compatibility

M.2 (S80) 3IE7 conforms to CE and FCC requirements.

Reliability	Reference standards
Electrostatic Discharge (ESD)	EC 61000-4-2 ESD

2.6 RoHS Compliance

M.2 (S80) 3IE7 is fully compliant with RoHS directive.

2.7 Reliability

Table 8: M.2 (S80) 3IE7 TBW

Parameter		Value
Read Cycles		Unlimited Read Cycles
Flash endurance		100,000 P/E cycles
Wear-Leveling Algorithm		Support
Bad Blocks Management		Support
DIE RAID Recovery		Support
Error Correct Code		Support
TBW* (Total Bytes Written) Units: TB		
Capacity	Sequential workload	Client workload
40GB	3400	2500
80GB	6800	5000
160GB	13600	10000
320GB	27200	20000
640GB	54400	40000
* Note: <ol style="list-style-type: none"> Sequential: Mainly sequential write, tested by Vdbench. Client: Follow JESD218 Test method and JESD219A Workload, tested by ULINK. (The capacity lower than 64GB client workload is not specified in JEDEC219A, the values are estimated.) Based on out-of-box performance. 		

2.8 Transfer Mode

M.2 (S80) 3IE7 support following transfer mode:

Serial ATA III 6.0Gbps

Serial ATA II 3.0Gbps

Serial ATA I 1.5Gbps

2.9 Pin Assignment

Innodisk M.2 (S80) 3IE7 uses a standard SATA pin-out. See following table for M.2 (S80) 3IE7 pin assignment.

Table 9: Innodisk M.2 (S80) 3IE7 Pin Assignment

Signal Name	Pin #	Pin #	Signal Name
		75	GND
3.3V	74	73	GND
3.3V	72	71	GND
3.3V	70	69	GND
NC	68	67	NC
Notch	66	65	Notch
Notch	64	63	Notch
Notch	62	61	Notch
Notch	60	59	Notch
NC	58		
NC	56	57	GND
NC	54	55	NC
NC	52	53	NC
NC	50	51	GND
NC	48	49	RX+
NC	46	47	RX-
NC	44	45	GND
NC	42	43	TX-
NC	40	41	TX+
DEVSLP	38	39	GND
NC	36	37	NC
NC	34	35	NC
NC	32	33	GND
NC	30	31	NC
NC	28	29	NC
NC	26	27	GND
NC	24	25	NC
NC	22	23	NC
NC	20	21	GND
Notch	18	19	Notch
Notch	16	17	Notch
Notch	14	15	Notch
Notch	12	13	Notch

DAS/DSS	10	11	NC
NC	8	9	NC
NC	6	7	NC
3.3V	4	5	NC
3.3V	2	3	GND
		1	GND

2.10 Mechanical Dimensions

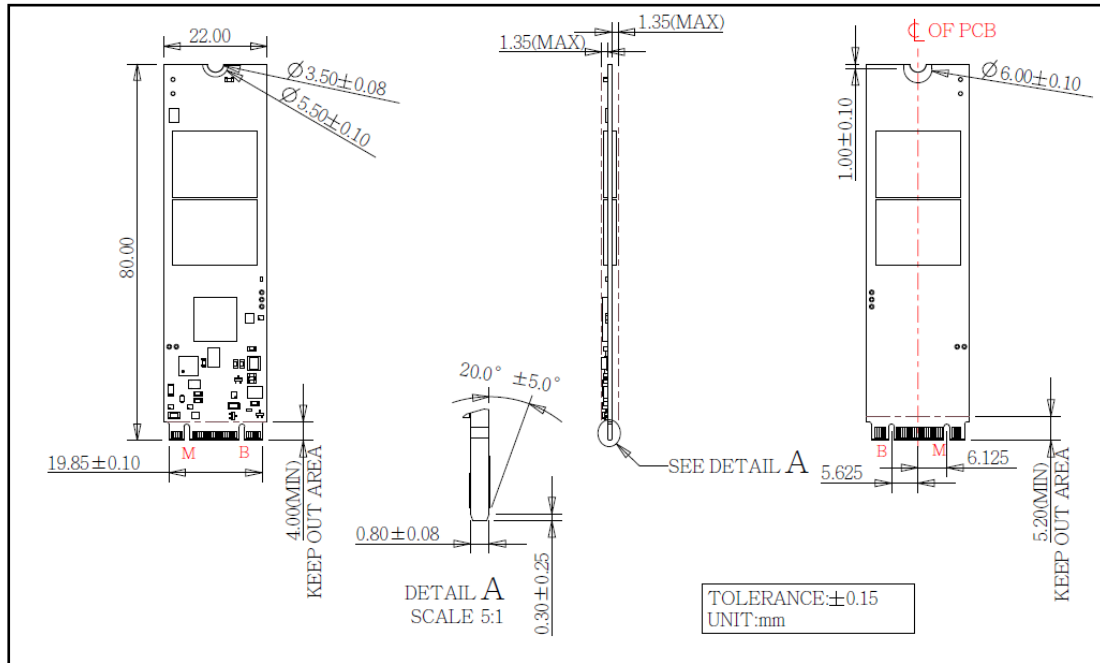

Figure 2: Innodisk M.2 (S80) 3IE7 diagram (BGA)

2.11 Assembly Weight

An Innodisk M.2 (S80) 3IE7 within flash ICs, 640 GB's weight is 8 grams approximately.

2.12 Seek Time

Innodisk M.2 (S80) 3IE7 is not a magnetic rotating design. There is no seek or rotational latency required.

2.13 Hot Plug

The SSD support hot plug function and can be removed or plugged-in during operation. User has to avoid hot plugging the SSD which is configured as boot device and installed operation system.

Surprise hot plug : The insertion of a SATA device into a backplane (combine signal and power) that has power present. The device powers up and initiates an OOB sequence.

Surprise hot removal: The removal of a SATA device from a powered backplane, without first being placed in a quiescent state.

2.14 NAND Flash Memory

Innodisk M.2 (S80) 3IE7 uses 3D Triple Level Cell (TLC) NAND flash memory, which is non-volatility, high reliability and high speed memory storage.

3. Theory of Operation

3.1 Overview

Figure 3 shows the operation of Innodisk M.2 (S80) 3IE7 from the system level, including the major hardware blocks.

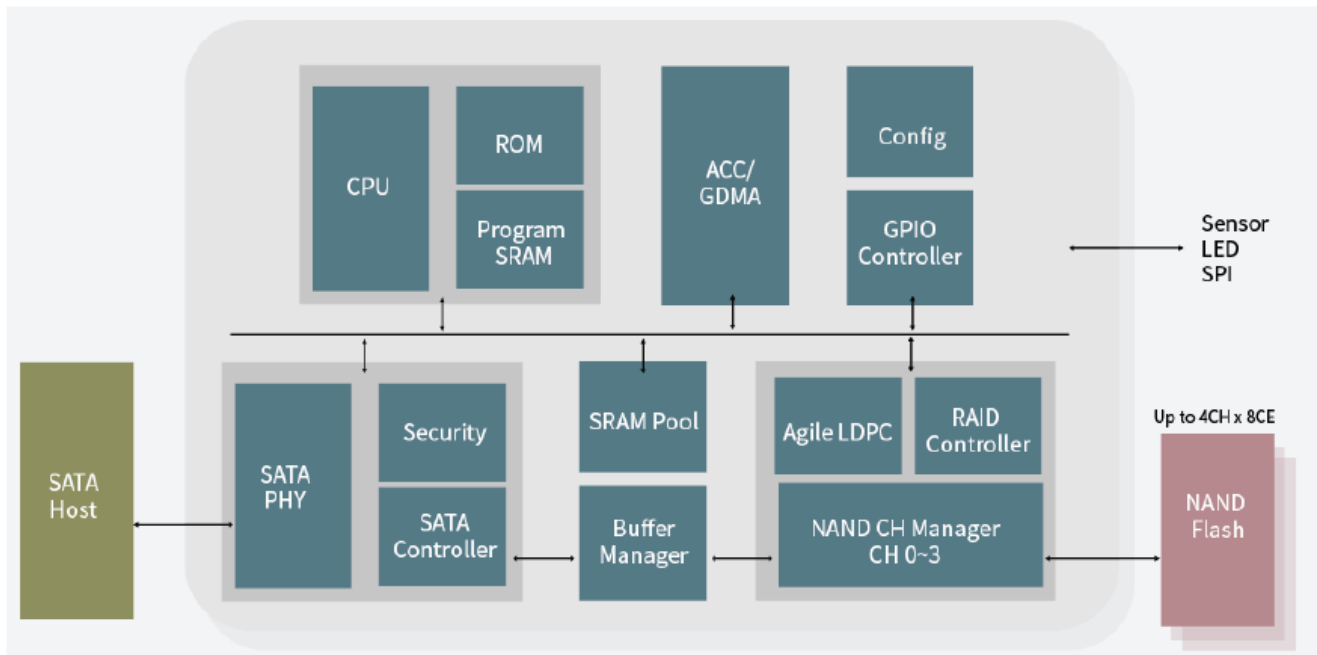

Figure 3: Innodisk M.2 (S80) 3IE7 Block Diagram

Innodisk M.2 (S80) 3IE7 integrates a SATA III controller and NAND flash memories. Communication with the host occurs through the host interface, using the standard ATA protocol. Communication with the flash device(s) occurs through the flash interface.

3.2 SATA III Controller

Innodisk M.2 (S80) 3IE7 is designed with a SATA III 6.0Gbps (Gen. 3) controller. The Serial ATA physical, link and transport layers are compliant with Serial ATA Gen 1, Gen 2 and Gen 3 specification (Gen 3 supports 1.5Gbps/3.0Gbps/6.0Gbps data rate). The controller has 4 channels for flash interface.

3.3 Error Detection and Correction

Innodisk M.2 (S80) 3IE7 is designed with hardware LDPC ECC engine with hard-decision and soft-decision decoding. Low-density parity-check (LDPC) codes have excellent error correcting performance close to the Shannon limit when decoded with the belief-propagation (BP) algorithm using soft-decision information.

3.4 Wear-Leveling

Flash memory can be erased within a limited number of times. This number is called the **erase cycle limit** or **write endurance limit** and is defined by the flash array vendor. The erase cycle limit applies to each individual erase block in the flash device.

Innodisk M.2 (S80) 3IE7 uses a static wear-leveling algorithm to ensure that consecutive writes of a specific sector are not written physically to the same page/block in the flash. This spreads flash media usage evenly across all pages, thereby extending flash lifetime.

3.5 Bad Blocks Management

Bad Blocks are blocks that contain one or more invalid bits whose reliability are not guaranteed. The Bad Blocks may be presented while the SSD is shipped, or may develop during the life time of the SSD. When the Bad Blocks is detected, it will be flagged, and not be used anymore. The SSD implement Bad Blocks management, Bad Blocks replacement, Error Correct Code to avoid data error occurred. The functions will be enabled automatically to transfer data from Bad Blocks to spare blocks, and correct error bit.

3.6 iData Guard

iData Guard is a comprehensive data protection mechanism that functions before and after a sudden power outage to SSD. Low-power detection terminates data writing before an abnormal power-off, while table-remapping after power-on deletes corrupt data and maintains data integrity. iData Guard provides effective power cycling management, preventing data stored in flash from degrading with use.

3.7 Garbage Collection

Garbage collection is used to maintain data consistency and perform continual data cleansing on SSDs. It runs as a background process, freeing up valuable controller resources while sorting good data into available blocks, and deleting bad blocks. It also significantly reduces write operations to the drive, thereby increasing the SSD's speed and lifespan.

3.8 Trim

The Trim command is designed to enable the operating system to notify the SSD which pages no longer contain valid data due to erases either by the user or operating system itself. During a delete operation, the OS will mark the sectors as free for new data and send a Trim command to the SSD to mark them as not containing valid data. After that the SSD knows not to preserve the contents of the block when writing a page, resulting in less write amplification with fewer writes to the flash, higher write speed, and increased drive life.

3.9 iPower Guard

iPower Guard technology is a set of preventive measures that protect the SSD in an unstable power supply environment. This comprehensive package comprises safeguards for startup and shutdown to maintain device performance and ensure data integrity.

3.10 Die RAID

Die RAID is a controller function which leveraged user capacity to back up the data in NAND flash. Die RAID supported can ensure the user data in the NAND Flash more consistent in certain scenario. Innodisk M.2 (S80) 3IE7 series is default enable the Die RAID function for the industrial application.

3.11 Thermal Throttling

Thermal throttling is a protective mechanism designed to safeguard components from potential damage caused by excessive temperatures. When an SSD approaches a critical temperature threshold, Innodisk firmware activates the thermal throttling mechanism to regulate the SSD's temperature. Thermal throttling is crucial for SSDs since it prevents drive damage, which could otherwise result in data loss. However, it's worth noting that when thermal throttling is activated, read and write tasks may experience a reduction in speed.

4. Installation Requirements

4.1 M.2 (S80) 3IE7 Pin Directions

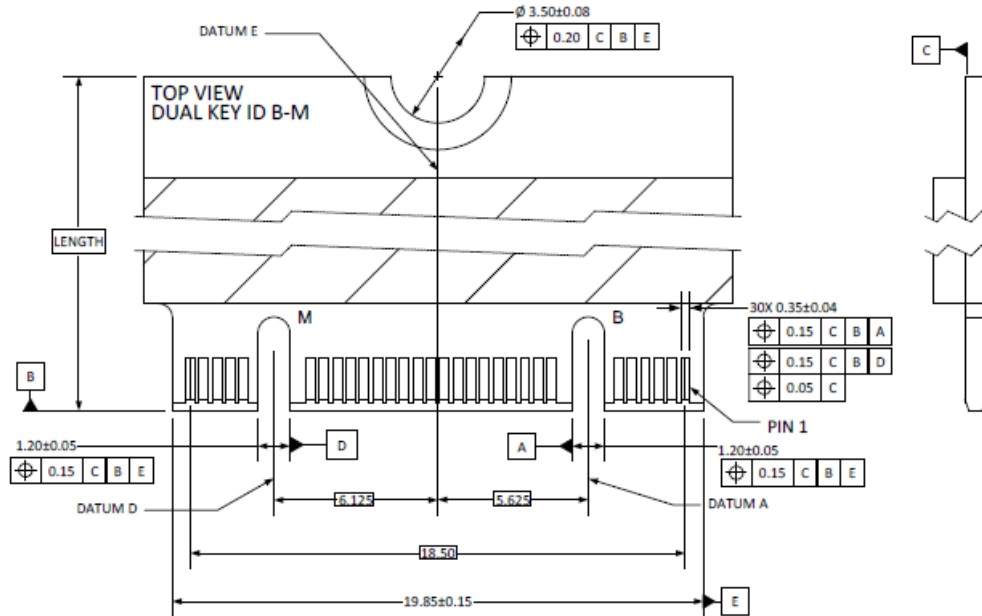

Figure 4: Signal Segment and Power Segment

4.2 Electrical Connections for M.2 (S80) 3IE7

A Serial ATA device may be either directly connected to a host or connected to a host through a cable. For connection via cable, the cable should be no longer than 1meter. The SATA interface has a separate connector for the power supply. Please refer to the pin description for further details.

4.3 Device Drive

No additional device drives are required. The Innodisk M.2 (S80) 3IE7 can be configured as a boot device.

5. SMART Feature Set

Innodisk 3IE7 series support the SMART command set and defines some vendor-specific data to report SMART attributes of SSD.

Table 10: SMART command

Value	Command	Value	Command
D0h	Read Data	D5h	Read Log
D1h	Read Attribute Threshold	D6h	Return Status
D2h	Enable/Disable Auto save	D8h	Enable SMART Operations
D3h	Save Attribute Values	D9h	Disable SMART Operations
D4h	Execute OFF-LINE Immediate	DAh	Return Status

5.1 SMART Attributes

Innodisk 3IE7 series SMART data attributes are listed in following table.

Table 11: SMART attribute

Attribute ID (hex)	Value	Raw Attribute Value						Rsv	Attribute Name
01	X								Read Error Rate
05	X	LSB	MSB	00	00	00	00	00	Later Bad
09	LSB	LSB	MSB	00	00	00	00	00	Power-On hours Count
0C	LSB	LSB	MSB	00	00	00	00	00	Drive Power Cycle Count
A3	X	LSB			MSB	00	00	00	Total Bad Block Count
A5	LSB	LSB			MSB	00	00	00	Max Erase count
A7	LSB	LSB			MSB	00	00	00	Avg Erase count
A9	LSB	LSB	00	00	00	00	00	00	Device Life
AA	X	LSB	MSB	00	00	00	00	00	Spare Block Count
AB	LSB	LSB	MSB	00	00	00	00	00	Program fail count
AC	LSB	LSB	MSB	00	00	00	00	00	Erase fail count
C0	LSB	LSB	MSB	00	00	00	00	00	Unexpected Power Loss Count
C2	LSB			MIN		MAX	00	00	Temperature

E5		ID 0	ID 1	ID 2	ID 3	ID 4	ID 5		Flash ID
EB			MSB	LSB	MSB	LSB	MSB	LSB	Later bad block info (Read/Write/Erase)
F1	00	LSB			MSB	00	00	00	Total LBA written(LBA=32MB)
F2	00	LSB			MSB	00	00	00	Total LBA read(LBA=32MB)

6. Part Number Rule

CODE	1	2	3	4	5	6	7	8	9	10	11	12	13	14	15	16	17	18	19	20	21
	D	H	M	2	8	-	4	0	G	D	K	1	K	C	A	D	F	-	X	X	X
Definition																					
Code 1st (Disk)											Code 14th (Operation Temperature)										
D : Disk											C: Standard Grade (0°C~ +70°C)										
Code 2nd (Feature set)											Code 15th (Internal control)										
H : iSLC series											W: Industrial Grade (-40°C~85°C)										
Code 3rd ~5th (Form factor)											Code 16th (Channel of data transfer)										
M28: M.2 Type 2280-D2-B-M											A: BGA PCB version.										
Code 7th ~9th (Capacity)											Code 17th (Flash Type)										
40G: 40GB			80G: 80GB			A60:160GB					D: Dual Channels										
D2G: 320GB			F4G: 640GB								Q: Quad Channels										
Code 10th ~12th (Controller)											Code 19th ~21st (Customize code)										
DK1: SATA 3IE7											F: Kioxia 3D TLC										
Code 13th (Flash mode)											Code 19th ~21st (Customize code)										
K: 112 layers 3D TLC																					