

Datasheet

# SATADOM-SV

## 3IE7 series

- SATA III solution for industrial field
- Exclusive L<sup>3</sup> architecture
- DRAM-less, 100% data integrity
- Excellent random performance
- Designed with hardware LDPC ECC engine
- Built-in Pin 8 power supply



## Introduction

Innodisk SATADOM-SV 3IE7 is characterized by L<sup>3</sup> architecture with the latest SATA III (6.0GHz) Marvell NAND controller. Innodisk's exclusive L<sup>3</sup> architecture is L<sup>2</sup> architecture multiplied LDPC (Low Density Parity Check). L<sup>2</sup> (Long Life) architecture is a 4K mapping algorithm that reduces WAF and features a real-time wear leveling algorithm to provide high performance and prolong lifespan with exceptional reliability.

Innodisk SATADOM-SV 3IE7 is designed for industrial field, and supports several standard features, including TRIM, NCQ, and S.M.A.R.T. In addition, Innodisk's exclusive industrial-oriented firmware provides a flexible customization service, making it perfect for a variety of industrial applications.

The innovative Pin 8 uses the SATA connector itself as a power supply to drive the device without external cables. It could be connected directly to the SATA on-board socket on customer's system without additional power cable. Besides, the booting time for operation and the power consumption is less than hard disk drive (HDD), and can work under harsh environment compile with ATA protocol, no additional drives are required, and the SSD can be configured as a boot device or data storage device.

# SATADOM-SV 3IE7 series

## Diagram

Contact us for more information about the SATADOM-SV 3IE7.

Innodisk is a service-driven provider of industrial embedded flash storage and Dram products and technologies, with a focus on the cloud computing, industrial/embedded, and aerospace and defense industries.

### Headquarters (Taiwan)

5F., No. 237, Sec. 1, Datong Rd., Xizhi Dist., New Taipei City, Taiwan (R.O.C.)  
Tel: +886-2-7703-3000  
Email: sales@innodisk.com

### Branch Offices:

USA  
[usasales@innodisk.com](mailto:usasales@innodisk.com)  
+1-510-770-9421  
Europe  
[eusales@innodisk.com](mailto:eusales@innodisk.com)  
+31-40-3045-400  
Japan  
[jpsales@innodisk.com](mailto:jpsales@innodisk.com)  
+81-3-6667-0161  
China  
[sales\\_cn@innodisk.com](mailto:sales_cn@innodisk.com)  
+86-755-21673689  
[www.innodisk.com](http://www.innodisk.com)

© 2021 Innodisk Corporation.  
All right reserved. Specifications are subject to change without prior notice.

20231101

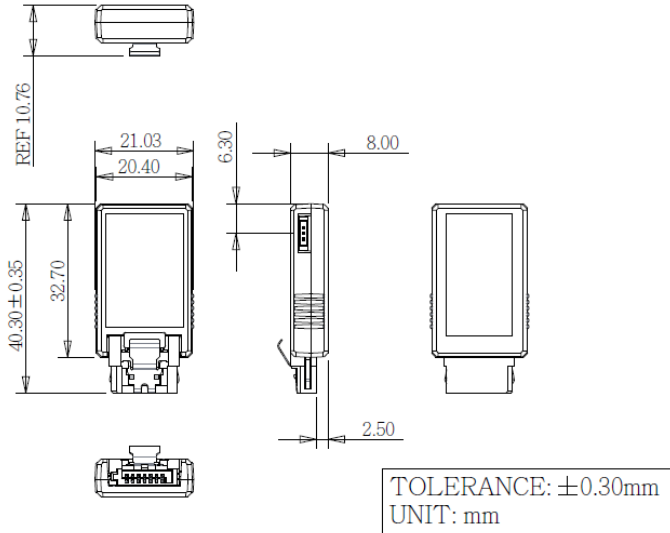

## Specifications

Interface	SATA III
Flash Type	iSLC (3D TLC)
Capacity	20GB~160GB
Max. Channels	2
Sequential R/W (MB/sec, max.)	550/510
Max. Power Consumption	1.6W
Thermal Sensor	√
Extended DRAM buffer	-
H/W Write Protect	-
ATA Security	√
S.M.A.R.T.	√
Dimension (WxLxH)	40.3 x 21.03 x 10.76 mm
Environment	Vibration: 20G @7~2000Hz Shock: 1500G @ 0.5ms Storage Temperature: -55°C ~ +95°C MTBF: 3 million hours

## Ordering Information

	20GB	40GB	80GB	160GB
Standard Grade (0°C ~ +70°C)	DHSSV-20GDK1KCASL*	DHSSV-40GDK1KCADL*	DHSSV-80GDK1KCADL*	DHSSV-A60DK1KCADL*
Industrial Grade (-40°C ~ +85°C)	DHSSV-20GDK1KWASL*	DHSSV-40GDK1KWADL*	DHSSV-80GDK1KWADL*	DHSSV-A60DK1KWADL*

\*=A-> Pin 8+ power cable / \*=B-> Pin 8+ Pin 7