

SATADOM-SV

3IE7 Series

Ultra iSLC

Customer: _____

Customer

Part Number: _____

Innodisk

Part Number: _____

Innodisk

Model Name: _____

Date: _____

Innodisk Approver	Customer Approver

**Total Solution For
Industrial Flash Storage**

Table of contents

1. PRODUCT OVERVIEW	7
1.1 INTRODUCTION OF INNO DISK SATADOM-SV 3IE7	7
1.2 PRODUCT VIEW AND MODELS	7
1.3 SATA INTERFACE	7
2. PRODUCT SPECIFICATIONS	8
2.1 CAPACITY AND DEVICE PARAMETERS	8
2.2 PERFORMANCE	8
2.3 ELECTRICAL SPECIFICATIONS	8
2.3.1 Power Requirement	8
2.3.2 Power Consumption	9
2.4 ENVIRONMENTAL SPECIFICATIONS	9
2.4.1 Temperature Ranges	9
2.4.2 Humidity	9
2.4.3 Shock and Vibration	9
2.4.4 Mean Time between Failures (MTBF)	9
2.5 CE AND FCC COMPATIBILITY	10
2.6 RoHS COMPLIANCE	10
2.7 RELIABILITY	10
2.8 TRANSFER MODE	10
2.9 PIN ASSIGNMENT	11
SATADOM-SV 3IE7 DEFAULT POWER SUPPLY THROUGH PIN7 OR PIN8	11
EXTERNAL POWER CABLE AS AN OPTIONAL CHOSE WITH SEPARATED PN END OF A.	11
2.10 MECHANICAL DIMENSIONS	11
2.11 ASSEMBLY WEIGHT	12
2.12 SEEK TIME	12
2.13 HOT PLUG	12
2.14 NAND FLASH MEMORY	12
3. THEORY OF OPERATION	13
3.1 OVERVIEW	13
3.2 SATA III CONTROLLER	13
3.3 ERROR DETECTION AND CORRECTION	13
3.4 WEAR-LEVELING	14
3.5 BAD BLOCKS MANAGEMENT	14
3.6 iDATA GUARD	14
3.7 GARBAGE COLLECTION	14
3.8 TRIM	14
3.9 iPOWER GUARD	15

3.10 DIE RAID	15
4. INSTALLATION REQUIREMENTS	16
4.1 SATADOM-SV 3IE7 PIN DIRECTIONS	16
4.2 ELECTRICAL CONNECTIONS FOR SATADOM-SV 3IE7	16
4.3 DEVICE DRIVE	16
4.4 POWER SUPPLY FOR SATADOM.....	16
<i>4.4.1 Power Cable</i>	<i>16</i>
<i>4.4.2 Pin8 and Pin7 VCC.....</i>	<i>17</i>
5. PART NUMBER RULE	18

REVISION HISTORY

Revision	Description	Date
V1.0	First Released	July, 2023
V1.1	Revise Product View & PN Rule	Aug., 2023
V1.2	Update 160GB Performance & Power Consumption	Aug., 2023
V1.3	Update PN rule	Feb., 2024

List of Tables

TABLE 1: DEVICE PARAMETERS	8
TABLE 2: PERFORMANCE	8
TABLE 3: INNODISK SATADOM-SV 3IE7 POWER REQUIREMENT	8
TABLE 4: POWER CONSUMPTION	9
TABLE 5: TEMPERATURE RANGE FOR SATADOM-SV 3IE7	9
TABLE 6: SHOCK/VIBRATION TESTING FOR SATADOM-SV 3IE7	9
TABLE 7: SATADOM-SV 3IE7 MTBF	10
TABLE 8: SATADOM-SV 3IE7 TBW	10
TABLE 9: INNODISK SATADOM-SV 3IE7 PIN ASSIGNMENT	11

List of Figures

FIGURE 1: INNODISK SATADOM-SV 3IE7	7
FIGURE 2: INNODISK SATADOM-SV 3IE7 MECHANICAL DIAGRAM	11
FIGURE 3: INNODISK SATADOM-SV 3IE7 BLOCK DIAGRAM	13
FIGURE 4: SIGNAL SEGMENT AND POWER SEGMENT	16
FIGURE 5: STANDARD POWER CABLE	16
FIGURE 6: PIN 8 / PIN 7 HOST DESIGN IN REFERENCE CIRCUIT	17

1. Product Overview

1.1 Introduction of InnoDisk SATADOM-SV 3IE7

Innodisk SATADOM-SV 3IE7 is characterized by L³ architecture with the latest SATA III (6.0GHz) Marvell NAND controller. Innodisk's exclusive L³ architecture is L² architecture multiplied LDPC (Low Density Parity Check). L² (Long Life) architecture is a 4K mapping algorithm that reduces WAF and features a real-time wear leveling algorithm to provide high performance and prolong lifespan with exceptional reliability. Innodisk SATADOM-SV 3IE7 is designed for industrial field, and supports several standard features, including TRIM, NCQ, and S.M.A.R.T. In addition, Innodisk's exclusive industrial-oriented firmware provides a flexible customization service, making it perfect for a variety of industrial applications.

CAUTION *TRIM must be enabled.*

TRIM enables SSD's controller to skip invalid data instead of moving. It can free up significant amount of resources, extends the lifespan of SSD by reducing erase, and write cycles on the SSD. Innodisk's handling of garbage collection along with TRIM command improves write performance on SSDs.

1.2 Product View and Models

Innodisk SATADOM-SV 3IE7 is available in follow capacities within 3D TLC flash ICs.

SATADOM-SV 3IE7 20GB

SATADOM-SV 3IE7 40GB

SATADOM-SV 3IE7 80GB

SATADOM-SV 3IE7 160GB



Figure 1: Innodisk SATADOM-SV 3IE7

1.3 SATA Interface

Innodisk SATADOM-SV 3IE7 supports SATA III interface, and compliant with SATA I and SATA II.

2. Product Specifications

2.1 Capacity and Device Parameters

SATADOM-SV 3IE7 device parameters are shown in Table 1.

Table 1: Device parameters

Capacity	Cylinders	Heads	Sectors	LBA	User Capacity(MB)
20GB	16383	16	63	39091248	19088
40GB	16383	16	63	78161328	38165
80GB	16383	16	63	156301488	76319
160GB	16383	16	63	312581808	152628

2.2 Performance

Burst Transfer Rate: 6.0Gbps

Table 2: Performance

Capacity	Unit	20GB	40GB	80GB	160GB
Sequential* Read (Q32T1)	MB/s	260	430	420	550
Sequential* Write (Q32T1)		130	260	260	510
4KB Random** Read (Q32T1)	IOPS	20,000	36,000	35,000	19,000
4KB Random** Write (Q32T1)		34,000	61,000	61,000	73,000

Note: * Sequential performance is based on CrystalDiskMark 6.0.2 with file size 1000MB

** Random performance is based on IO meter with Queue Depth 32

2.3 Electrical Specifications

2.3.1 Power Requirement

Table 3: Innodisk SATADOM-SV 3IE7 Power Requirement

Item	Symbol	Rating	Unit
Input voltage	V _{IN}	+5 DC +- 5%	V

2.3.2 Power Consumption

Table 4: Power Consumption

Mode	Power Consumption (W)
Read	1.6
Write	1.6
Idle	0.8
Pin 7/ Pin8 VCC Initial*	3

Target: 160GB SATADOM-SV 3IE7

***To design in Pin7/8 VCC on motherboard, 5V with 1A power supply is requested.**

2.4 Environmental Specifications

2.4.1 Temperature Ranges

Table 5: Temperature range for SATADOM-SV 3IE7

Temperature	Range
Operating	Standard Grade: 0°C to +70°C
	Industrial Grade: -40°C to +85°C
Storage	-40°C to +85°C

2.4.2 Humidity

Relative Humidity: 10-95%, non-condensing

2.4.3 Shock and Vibration

Table 6: Shock/Vibration Testing for SATADOM-SV 3IE7

Reliability	Test Conditions	Reference Standards
Vibration	7 Hz to 2K Hz, 20G, 3 axes	IEC 68-2-6
Mechanical Shock	Duration: 0.5ms, 1500 G, 3 axes	IEC 68-2-27

2.4.4 Mean Time between Failures (MTBF)

Table 7 summarizes the MTBF prediction results for various SATADOM-SV 3IE7 configurations. The analysis was performed using a RAM Commander™ failure rate prediction.

- **Failure Rate:** The total number of failures within an item population, divided by the total number of life units expended by that population, during a particular measurement interval under stated condition.
- **Mean Time between Failures (MTBF):** A basic measure of reliability for repairable items: The mean number of life units during which all parts of the item perform within their specified limits, during a particular measurement interval under stated conditions.

Table 7: SATADOM-SV 3IE7 MTBF

Product	Condition	MTBF (Hours)
Innodisk SATADOM-SV 3IE7	Telcordia SR-332 GB, 25°C	>3,000,000

2.5 CE and FCC Compatibility

SATADOM-SV 3IE7 conforms to CE and FCC requirements.

2.6 RoHS Compliance

SATADOM-SV 3IE7 is fully compliant with RoHS directive.

2.7 Reliability

Table 8: SATADOM-SV 3IE7 TBW

Parameter		Value
Read Cycles		Unlimited Read Cycles
Flash endurance		100,000 P/E cycles
Wear-Leveling Algorithm		Support
Bad Blocks Management		Support
Error Correct Code		Support
TBW* (Total Bytes Written) Unit: TB		
Capacity	Sequential workload	Client workload
20GB	1775	1250
40GB	3551	2500
80GB	7102	5000
160GB	14204	10000
* Note:		
1. Sequential: Mainly sequential write, tested by Vdbench.		
2. Client: Follow JESD218 Test method and JESD219A Workload, tested by ULINK. (The capacity lower than 64GB client workload is not specified in JEDEC219A, the values are estimated.)		
3. Based on out-of-box performance.		

2.8 Transfer Mode

SATADOM-SV 3IE7 support following transfer mode:

Serial ATA I 1.5Gbps

Serial ATA II 3.0Gbps

Serial ATA III 6.0Gbps

2.9 Pin Assignment

Innodisk SATADOM-SV 3IE7 uses a standard SATA pin-out. See Table 8 for SATADOM-SV 3IE7 pin assignment.

Table 9: Innodisk SATADOM-SV 3IE7 Pin Assignment

Name	Type	Description
Pin 0	GND	Shielding
Pin 1	GND	Shielding
Pin 2	A+	Differential signal to A
Pin 3	A-	Differential signal to A-
Pin 4	GND	Shielding
Pin 5	B-	Differential signal to B-
Pin 6	B+	Differential signal to B
Pin 7	GND/ Vcc*	Shielding/ +5V Power*
Pin 8	VCC	+5V Power

SATADOM-SV 3IE7 default power supply through pin7 or pin8.

External power cable as an optional chose with separated PN end of A.

2.10 Mechanical Dimensions

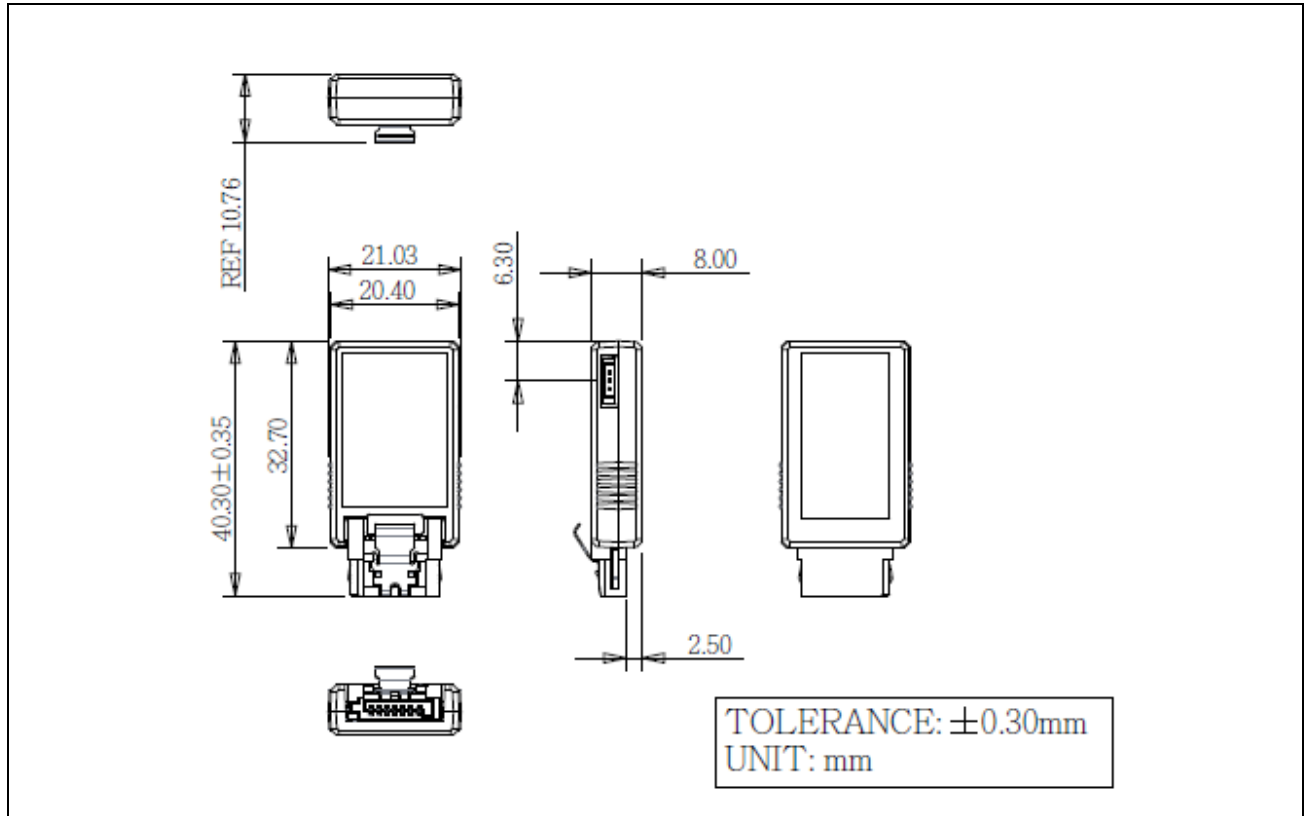

Figure 2: Innodisk SATADOM-SV 3IE7 mechanical diagram

2.11 Assembly Weight

An Innodisk SATADOM-SV 3IE7 within flash ICs, 32GB's weight is 7 grams approximately.

2.12 Seek Time

Innodisk SATADOM-SV 3IE7 is not a magnetic rotating design. There is no seek or rotational latency required.

2.13 Hot Plug

The SSD support hot plug function and can be removed or plugged-in during operation. User has to avoid hot plugging the SSD which is configured as boot device and installed operation system.

Surprise hot plug: The insertion of a SATA device into a backplane (combine signal and power) that has power present. The device powers up and initiates an OOB sequence.

Surprise hot removal: The removal of a SATA device from a powered backplane, without first being placed in a quiescent state.

2.14 NAND Flash Memory

Innodisk SATADOM-SV 3IE7 uses 3D TLC NAND flash memory, which is non-volatility, high reliability and high speed memory storage. Each cell stores 3 bits or holds four states per cell. Read or Write data to flash memory for SSD is control by microprocessor.

3. Theory of Operation

3.1 Overview

Figure 3 shows the operation of Innodisk SATADOM-SV 3IE7 from the system level, including the major hardware blocks.

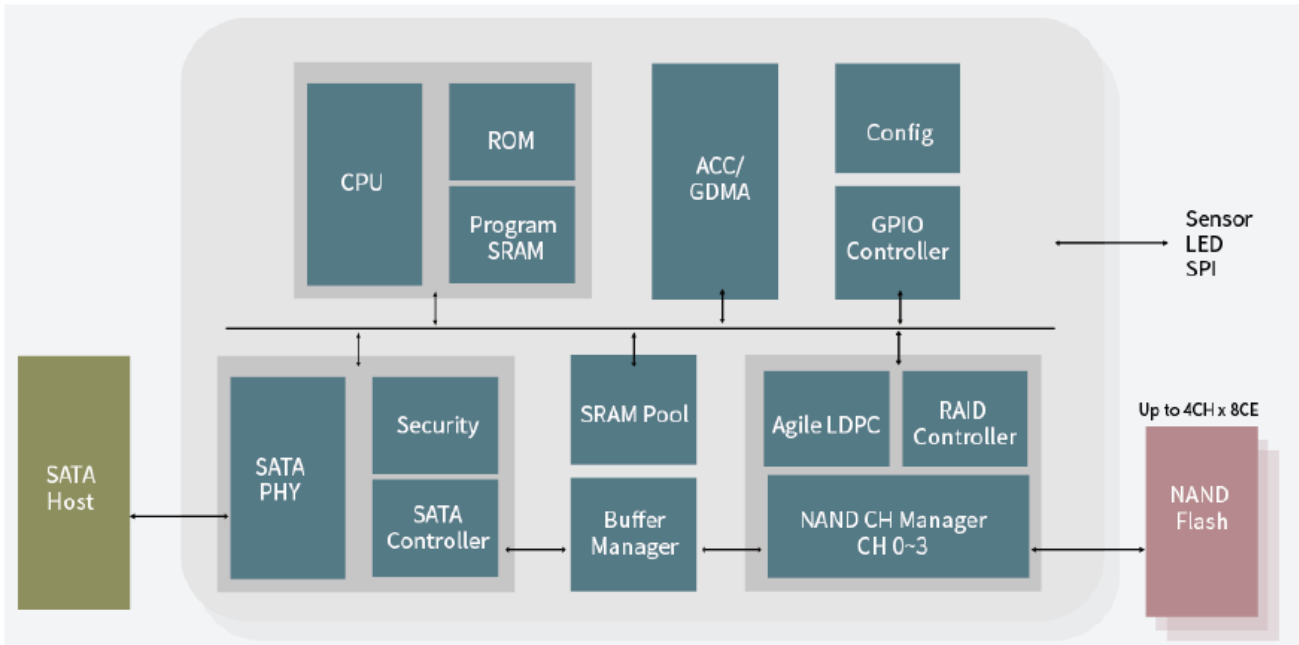

Figure 3: Innodisk SATADOM-SV 3IE7 Block Diagram

Innodisk SATADOM-SV 3IE7 integrates a SATA III controller and NAND flash memories. Communication with the host occurs through the host interface, using the standard ATA protocol. Communication with the flash device(s) occurs through the flash interface.

3.2 SATA III Controller

Innodisk SATADOM-SV 3IE7 is designed with ID 301, a SATA III 6.0Gbps (Gen. 3) controller. The Serial ATA physical, link and transport layers are compliant with Serial ATA Gen 1, Gen 2 and Gen 3 specification (Gen 3 supports 1.5Gbps/3.0Gbps/6.0Gbps data rate). The controller has 2 channels for flash interface.

3.3 Error Detection and Correction

Innodisk SATADOM-SV 3IE7 is designed with hardware LDPC ECC engine with hard-decision and soft-decision decoding. Low-density parity-check (LDPC) codes have excellent error correcting performance close to the Shannon limit when decoded with the belief-propagation (BP) algorithm using soft-decision information.

3.4 Wear-Leveling

Flash memory can be erased within a limited number of times. This number is called the **erase cycle limit** or **write endurance limit** and is defined by the flash array vendor. The erase cycle limit applies to each individual erase block in the flash device.

Innodisk SATADOM-SV 3IE7 uses a static wear-leveling algorithm to ensure that consecutive writes of a specific sector are not written physically to the same page/block in the flash. This spreads flash media usage evenly across all pages, thereby extending flash lifetime.

3.5 Bad Blocks Management

Bad Blocks are blocks that contain one or more invalid bits whose reliability are not guaranteed. The Bad Blocks may be presented while the SSD is shipped, or may develop during the life time of the SSD. When the Bad Blocks is detected, it will be flagged, and not be used anymore. The SSD implement Bad Blocks management, Bad Blocks replacement, Error Correct Code to avoid data error occurred. The functions will be enabled automatically to transfer data from Bad Blocks to spare blocks, and correct error bit.

3.6 iData Guard

Innodisk's iData Guard is a comprehensive data protection mechanism that functions before and after a sudden power outage to SSD. Low-power detection terminates data writing before an abnormal power-off, while table-remapping after power-on deletes corrupt data and maintains data integrity. Innodisk's iData Guard provides effective power cycling management, preventing data stored in flash from degrading with use.

3.7 Garbage Collection

Garbage collection is used to maintain data consistency and perform continual data cleansing on SSDs. It runs as a background process, freeing up valuable controller resources while sorting good data into available blocks, and deleting bad blocks. It also significantly reduces write operations to the drive, thereby increasing the SSD's speed and lifespan.

3.8 TRIM

The TRIM command is designed to enable the operating system to notify the SSD which pages no longer contain valid data due to erases either by the user or operating system itself. During a delete operation, the OS will mark the sectors as free for new data and send a TRIM command to the SSD to mark them as not containing valid data. After that the SSD knows not to preserve the contents of the block when writing a page, resulting in less write amplification with fewer writes to the flash, higher write speed, and increased drive life.

3.9 iPower Guard

iPower Guard technology is a set of preventive measures that protect the SSD in an unstable power supply environment. This comprehensive package comprises safeguards for startup and shutdown to maintain device performance and ensure data integrity.

3.10 Die RAID

Die RAID is a controller function which leveraged user capacity to back up the data in NAND flash. Die RAID supported can ensure the user data in the NAND Flash more consistent in certain scenario. Innodisk SATADOM-SV 3IE7 series is default enable the Die RAID function for the industrial application.

4. Installation Requirements

4.1 SATADOM-SV 3IE7 Pin Directions

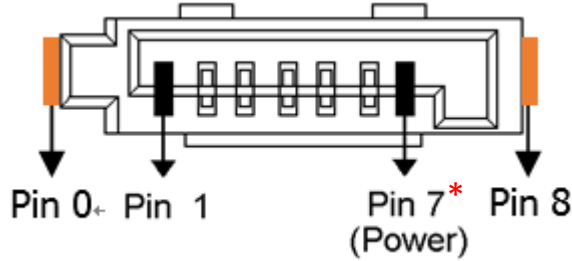

Figure 4: Signal Segment and Power Segment

***SATADOM-SV 3IE7 default power supply through pin7 or pin8.**

External power cable as an optional chose with separated PN end of A.

4.2 Electrical Connections for SATADOM-SV 3IE7

A Serial ATA device may be either directly connected to a host or connected to a host through a cable. For connection via cable, the cable should be no longer than 1meter. The SATA interface has a separate connector for the power supply. Please refer to the pin description for further details.

4.3 Device Drive

No additional device drives are required. The Innodisk SATADOM-SV 3IE7 can be configured as a boot device.

4.4 Power Supply for SATADOM

4.4.1 Power Cable

A power cable is shipped with each SATADOM product, which has standard 4 pins power connector and special 3 pins power connector for SATADOM. The male and female power connector of SATADOM have foolproof design to avoid misconnection, please check it before power on. Innodisk also can customize the power connector for different host power socket design.

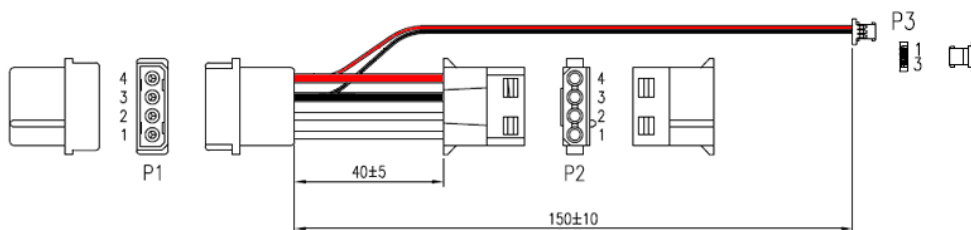

Figure 5: Standard power cable

4.4.2 Pin8 and Pin7 VCC

Innodisk’s SATADOM SSDs provide an elegant, compact option for SSD storage in embedded systems, industrial PCs and server motherboards with their small form factor that connects directly to the SATA connector on the motherboard. This simplified SSD design not only frees up a precious drive bay for other storage options but eliminates messy, obtrusive SATA data cabling. Innodisk’s patented Pin7 and Pin 8 SATA Power technologies take the cable-less concept to the next step by also eliminating the need for power cables for a 100% cable-less, shock resistant, space saving plug-and-play storage solution that optimizes airflow and makes the best use of limited board space in embedded and rackmount server systems.

SATADOM-SV 3IE7 series with Pin8/Pin7 VCC, it is defined Pin8/Pin7 as VCC on the SATA connector. Thus the power would come from SATA connector Pin8/Pin7 VCC. Customers DO NOT have to use the power cable for power supply. Such a cable-less design of SATADOM-SV 3IE7 series with Pin8/Pin7 VCC brings more convenience to customers’ system. The followings are the points customers have to be careful of while designing in SATADOM-SV 3IE7 series with Pin8/Pin7 VCC.

When customers use SATADOM with Pin8/Pin7 VCC and the host SATA socket does not have power on Pin8/Pin7, external power must be provided to the SATADOM from the 3pin connector on the side. To have the advantages of SATADOM-SV 3IE7 series with Pin8/Pin7 VCC, and to avoid any potential damage on customer’s board designed with VCC power supply. Innodisk suggests that customers MUST design their board with a fuse which should be designed before the SATA socket Pin8/Pin7 VCC. In other words, customers are suggested NOT TO layout 5V VCC to SATA socket on board directly. A circuit diagram example to explain this is shown as below.

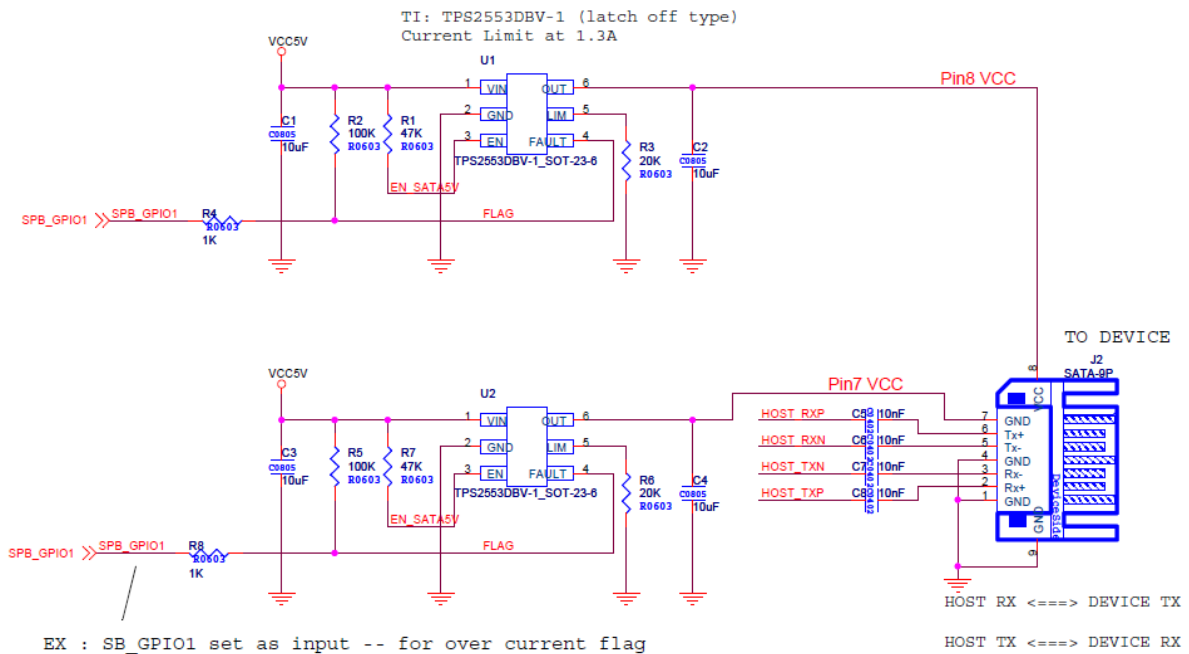

Figure 6: Pin 8 / Pin 7 host design in reference circuit

5. Part Number Rule

CODE	1	2	3	4	5	6	7	8	9	10	11	12	13	14	15	16	17	18	19	20	21
	D	H	S	S	V	-	4	0	G	D	K	1	K	C	A	D	L	B	-	X	X
Definition																					
Code 1st (Disk)											Code 14th (Operation Temperature)										
D: Disk											C: Standard Grade (0°C~ +70°C)										
Code 2nd (Feature set)											W: Industrial Grade (-40°C~ +85°C)										
H:iSLC											Code 15th (Internal control)										
Code 3rd ~5th (Form factor)											1~9: TSOP PCB version.										
SSV: SATADOM-SV											A~Z: BGA PCB version										
											Code 16th (Channel of data transfer)										
Code 7th ~9th (Capacity)											S: Single Channel										
20G:20GB	40G:40GB	80G:80GB	A60:160GB	D: Dual channel																	
Code 10th ~12th (Controller)											Code 17th (Flash Type)										
DK1: SATA 3IE7 series											L: Innodisk 3D TLC										
											Code 18th (pin7 type)										
Code 13th (Flash mode)											A: Pin7 & Pin8 version with external power cable										
K: 112 layers 3D TLC											B: Pin7 & Pin8 version										
											Code 20th~21st (Customize code)										