

Datasheet

U.2 SSD 4IG2-P series

- PCIe Gen. 4x4, NVMe 1.4
- Excellent data transfer speed
- Ultra iSLC technology
- Standard & Wide-temperature
- iPowerguard
- iDataguard
- LDPC ECC engine supported.
- End-to-end Data Path Protection (ETEP)
- 256-bit AES hardware-based encryption
- Support TCG Opal Function (Optional)



Introduction

Innodisk U.2 SSD 4IG2-P is an NVM Express SSD designed as PCIe SFF-8639 module with PCIe interface and 3D TLC NAND Flash. U.2 SSD 4IG2-P supports PCIe Gen 4x4, and it is compliant with NVMe 1.4 providing excellent performance. With sophisticated error detection and correction (ECC) functions, the module can ensure full End-to-end Data Path Protection that secures the data transmission between host system and NAND Flash.

Innodisk U.2 SSD 4IG2-P provides ultra-speed and high IOPS and offers maximum capacity up to 1.28TB, making the SSD optimal for server and heavy data workload applications.

U.2 SSD

4IG2-P series

Diagram

Contact us for more information about the U.2 SSD 4IG2-P.

Innodisk is a service-driven provider of industrial embedded flash and DRAM storage products and technologies, with a focus on the cloud computing, industrial/embedded, and aerospace and defense industries.

Headquarters (Taiwan)

5F., No. 237, Sec. 1, Datong Rd., Xizhi Dist., New Taipei City 221, Taiwan
Tel: +886-2-7703-3000
Email: sales@innodisk.com

Branch Offices:

USA
usasales@innodisk.com
+1-510-770-9421

Europe
eusales@innodisk.com
+31-40-3045-400

Japan
jpsales@innodisk.com
+81-3-6667-0161

China
sales_cn@innodisk.com
+86-755-21673689

www.innodisk.com

© 2022 Innodisk Corporation.
All right reserved. Specifications are subject to change without prior notice.

220240306

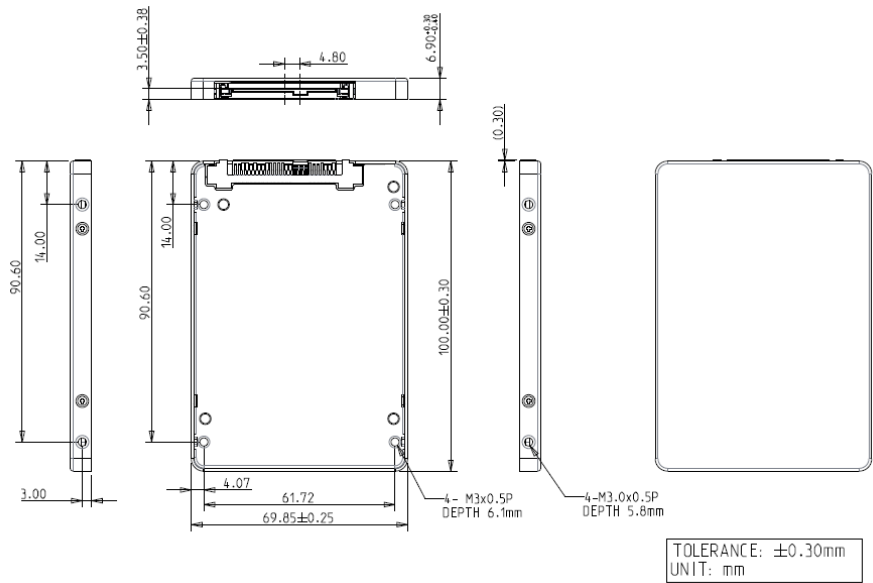

Specification

Interface	PCIe Gen. 4 x4
Flash Type	iSLC (3DTLC)
P/E cycle	100,000
Capacity	160GB~1.28TB
Max. Channels	8
Sequential R/W (MB/sec, max.)	6,900/4,900
Max. Power Consumption	12.1W
Thermal Sensor	√
External DRAM buffer	√
TCG Opal	√ (Optional)
H/W Write Protect	NA
iCell	NA
Dimension (WxLxH)	100.0 X 69.85 X 6.9 mm
Environment	Vibration: 20G @7~2000Hz Shock: 1500G @ 0.5ms Working Temperature: ST 0°C ~ +70°C, ; WT -40°C ~ +85°C Storage Temperature: -40°C ~ +85°C MTBF: 3 million hours

Ordering Information

Operation Temp.	160GB	320GB	640GB	1.28TB
Standard Grade (0°C ~ +70°C)	DHEU2-A60DP1KCAEL DHEU2-A60DP2KCAEL	DHEU2-D2GDP1KCAEL DHEU2-D2GDP2KCAEL	DHEU2-F4GDP1KCAEL DHEU2-F4GDP2KCAEL	DHEU2-1T2DP1KCAEL DHEU2-1T2DP2KCAEL
Industrial Grade (-40°C ~ +85°C)	DHEU2-A60DP1KWAEL DHEU2-A60DP2KWAEL	DHEU2-D2GDP1KWAEL DHEU2-D2GDP2KWAEL	DHEU2-F4GDP1KWAEL DHEU2-F4GDP2KWAEL	DHEU2-1T2DP1KWAEL DHEU2-1T2DP2KWAEL

For TCG OPAL function, the PN Code 10th~12th will be DP2.