

# M101TG

## 10.1" Windows Rugged Tablet PC with Intel® Core™ i5- 1135G7



### KEY FEATURES

- 10.1" 1920 x 1200 IPS LED Panel with direct optical bonding
- Intel® Core™ i5-1135G7 Tiger Lake processor
- IP65 waterproof and dustproof, MIL-STD-810H shock, vibration and drop resistance
- Sunlight readable with antiglare solution
- Hotswappable battery design
- USB Type-C port support power delivery 20V In



### SPECIFICATIONS

Display	
<b>Resolution</b>	1920x1200
<b>Contrast Ratio</b>	800:1
<b>View Angles</b>	85,85,85,85
<b>Viewability</b>	Anti-Glare touch treatment
<b>Size</b>	10.1 inches
<b>Panel Brightness</b>	800.0 nits
<b>Type</b>	Projected Capacitive Multi Touch
<b>Bonding</b>	Optical Bonding for Sunlight Viewability
System Specification	
<b>Processor</b>	Intel Core i5-1135G7 2.4GHz (up to 4.2GHz)
<b>Memory</b>	8GB DDR4 SDRAM 16GB DDR4 SDRAM (Optional) 32GB DDR4 SDRAM (Optional)
<b>Storage</b>	256GB SSD Additional storage available with micro SDXC card slot 512GB SSD (Optional) 1TB SSD (Optional) 2TB SSD (Optional)
<b>Security</b>	Trusted Platform Module (TPM) 2.0 Kensington Lock
<b>Operating System</b>	Windows 10 IoT Enterprise LTSC (64 bit) Windows 11 IoT Enterprise SAC (64 bit) (Optional)
<b>WLAN</b>	Support
<b>BT</b>	Support
<b>WWAN</b>	4G LTE (Optional) 5G (Optional)
<b>GNSS</b>	GPS, GLONASS
<b>RFID</b>	HF RFID reader 13.56 MHz (Optional)
<b>Sensors</b>	Light sensor/ G-sensor / Gyro
Camera	
<b>Front Camera</b>	2MP Front Camera
<b>Rear Camera</b>	8MP Rear Camera with auto-focus and LED light
Mechanical	
<b>Dimension</b>	271.8 x 197.2 x 21 mm
<b>Weight</b>	1.3 kg (2.86 lbs) with standard battery
<b>Cooling System</b>	Fan design
IO Ports	
<b>USB Port</b>	1 x USB 3.0 (Type A), 1 x USB 3.0 (Type-C support Power Delivery 20V In)
<b>SD Card Slot</b>	1 x Micro SDXC slot
<b>SIM Card Slot</b>	1 x Micro SIM card slot
<b>Video</b>	1 x Micro HDMI (Optional)
<b>Audio</b>	1 x Audio combo 3.5mm audio combo jack Dual Digital Mic With Noise Cancellation Dual Speaker
<b>Indicator</b>	4x LED Indicator for Power, Battery, HDD, RF status
<b>Docking Connector</b>	1 x 19-pin docking connector

Environment			
<b>Operating Humidity</b>	10% to 90% RH, non-condensing	<b>Operating Temperature</b>	-20°C to 60°C
<b>Storage Temperature</b>	-30°C to 70°C (-22°F to 158°F)	<b>Shock</b>	MIL-STD-810H Method 516.8 Procedure I
<b>Vibration</b>	MIL-STD-810H Method 514.8 Procedure I	<b>IP rating</b>	IP65
<b>Drop</b>	MIL-STD-810H Method 516.8, 4 ft	<b>EMC</b>	MIL-STD-461G CE101, CE102, RE101, RE102, CS118 (Default) MIL-STD-461G CS101, CS114, CS115, CS116, RS101, RS103 (Optional)
Certification			
<b>Certification</b>	CE, FCC		
Security Function			
<b>SOTI MobiControl</b>	SOTI MobiControl Compliance	<b>Kensington Lock</b>	Kensington Lock Support
Control			
<b>Button</b>	1 x Power, 1 x Home 2 x volume key 2 x Programmable function Keys		
Power			
<b>Battery</b>	Hot-swappable 11.55V, typ. 4558 mAh Li-Polymer Battery (3S2P) Optional 15.4V, typ. 5900 mAh Li-Polymer Battery (4S1P)	<b>Battery Operating Time</b>	Standard. Battery: 8 hours
<b>Power Rating</b>	19V DC	<b>Adapter</b>	100-240V, 50-60Hz / 19V DC
Accessory			
<b>Accessory</b>	Adapter and Power Cord Capacitive Stylus Standard Battery	<b>Optional Accessory</b>	Desk Dock (Optional) Vehicle Dock (without VGA output) (Optional) Vehicle Cradle (Optional) Vehicle Charger (Optional) High Capacity Battery (Optional) Hand Strap (Optional) Shoulder Strap (Optional) Carry Bag (Optional)
Barcode Scanner			
<b>Barcode Scanner</b>	1D/2D barcode reader (Optional)		

## DIMENSIONS UNIT:MM

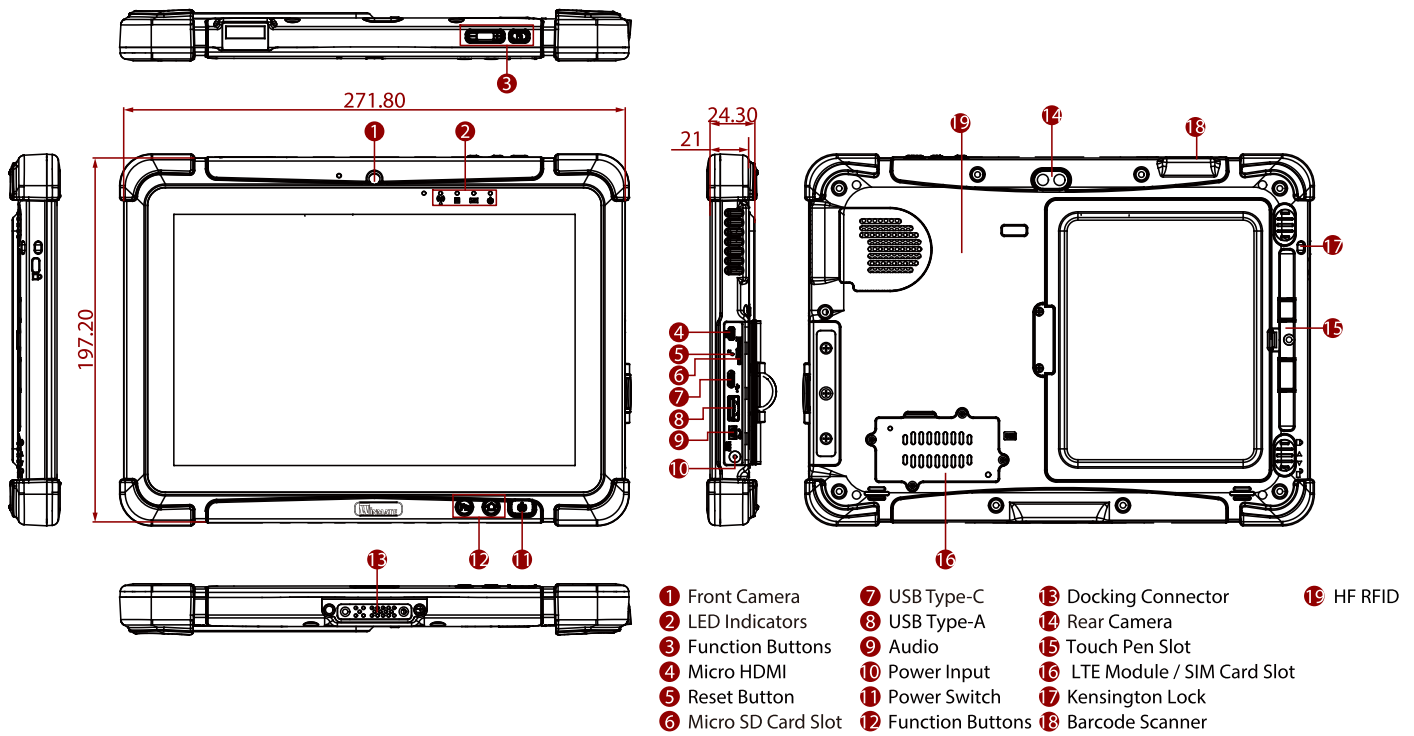

**NOTE**

1. Total usable memory will be less dependent upon actual system configuration.
2. The USB Type-C connector follows USB 3.0 standard, which does not support Alternate Mode (ALT).
3. Add-on modules require the expansion port option to be usable.
4. TPM 2.0 available upon request.
5. SOTI is available upon request.
6. Measured at dimming LCD brightness. Varies depending on the usage conditions, or when an external device is attached.
7. Length measurements do not include protrusions. Weight varies with options and active pen.
8. The drop test with a high-capacity battery must come with a hand strap.
9. Accessories and Integrated Options may vary depending on your configuration.
10. This is a simplified drawing and some components are not marked in detail.
11. The product shown in this datasheet is a standard model. For diagrams that contain customized or optional I/O, please contact the Winmate Sales Team for more information.