



**MODEL:
NANO-AL**

**EPIC SBC with 14nm Intel® Pentium®/Celeron®/Atom® SoC,
Dual HDMI, iDP, LVDS, Dual PCIe GbE, USB 3.2 Gen 1,
PCIe Mini, M.2, SATA 6Gb/s, COM and HD Audio, -40°C ~ 85°C**

User Manual

Revision

Date	Version	Changes
June 25, 2021	1.05	Updated Section 4.11: Software Installation Changed audio IC to ALC888S
September 12, 2018	1.04	Modified Section 3.2.16: LVDS Connector
May 28, 2018	1.03	Modified "Table 1-1: Model Variations"
May 3, 2018	1.02	Minor update
March 27, 2018	1.01	Changed the SIM card slot to optional item
December 11, 2017	1.00	Initial release

Copyright

COPYRIGHT NOTICE

The information in this document is subject to change without prior notice in order to improve reliability, design and function and does not represent a commitment on the part of the manufacturer.

In no event will the manufacturer be liable for direct, indirect, special, incidental, or consequential damages arising out of the use or inability to use the product or documentation, even if advised of the possibility of such damages.

This document contains proprietary information protected by copyright. All rights are reserved. No part of this manual may be reproduced by any mechanical, electronic, or other means in any form without prior written permission of the manufacturer.

TRADEMARKS

All registered trademarks and product names mentioned herein are used for identification purposes only and may be trademarks and/or registered trademarks of their respective owners.

Manual Conventions



WARNING

Warnings appear where overlooked details may cause damage to the equipment or result in personal injury. Warnings should be taken seriously.



CAUTION

Cautionary messages should be heeded to help reduce the chance of losing data or damaging the product.



NOTE

These messages inform the reader of essential but non-critical information. These messages should be read carefully as any directions or instructions contained therein can help avoid making mistakes.



HOT SURFACE

This symbol indicates a hot surface that should not be touched without taking care.

Table of Contents

1 INTRODUCTION.....	1
1.1 INTRODUCTION.....	2
1.2 MODEL VARIATIONS	3
1.3 FEATURES.....	3
1.4 CONNECTORS	4
1.5 DIMENSIONS.....	6
1.6 DATA FLOW	7
1.7 TECHNICAL SPECIFICATIONS	8
2 PACKING LIST.....	11
2.1 ANTI-STATIC PRECAUTIONS	12
2.2 UNPACKING PRECAUTIONS.....	12
2.3 PACKING LIST.....	13
2.4 OPTIONAL ITEMS	14
3 CONNECTORS	15
3.1 PERIPHERAL INTERFACE CONNECTORS.....	16
3.1.1 <i>Layout</i>	16
3.1.2 <i>Peripheral Interface Connectors</i>	17
3.1.3 <i>External Interface Panel Connectors</i>	18
3.2 INTERNAL PERIPHERAL CONNECTORS	19
3.2.1 <i>9 V ~ 30 V Power Connector</i>	19
3.2.2 <i>Audio Connector</i>	20
3.2.3 <i>Backlight Inverter Connector</i>	20
3.2.4 <i>Battery Connector</i>	21
3.2.5 <i>BIOS Debug Connector</i>	23
3.2.6 <i>Buzzer Connector</i>	24
3.2.7 <i>Chassis Intrusion Connector</i>	25
3.2.8 <i>CPU Fan Connector</i>	26
3.2.9 <i>Digital I/O Connector</i>	27
3.2.10 <i>EC Debug Connector</i>	28

3.2.11 Front Panel Connector.....	29
3.2.12 PC Connector.....	30
3.2.13 Internal DisplayPort Connector.....	31
3.2.14 Keyboard and Mouse Connector.....	32
3.2.15 LAN LED Connectors.....	33
3.2.16 LVDS Connector.....	34
3.2.17 microSD Card Slot (Optional).....	36
3.2.18 M.2 Slot.....	36
3.2.19 PCIe Mini Card Slot.....	37
3.2.20 Power Button (On-board).....	39
3.2.21 Power Button Connector.....	39
3.2.22 Reset Button Connector.....	40
3.2.23 SATA 6Gb/s Drive Connectors.....	41
3.2.24 SATA Power Connectors (5 V).....	42
3.2.25 Serial Port Connector, RS-232.....	43
3.2.26 Serial Port Connector, RS-232/422/485.....	43
3.2.27 SIM Card Slot (Optional).....	45
3.2.28 SMBus Connector.....	46
3.2.29 SO-DIMM Connector.....	46
3.2.30 SPI Flash Connector.....	47
3.2.31 SPI Flash Connector (EC).....	48
3.2.32 USB 2.0 Connector.....	49
3.3 EXTERNAL INTERFACE CONNECTORS.....	49
3.3.1 HDMI Connectors.....	50
3.3.2 LAN Connectors.....	51
3.3.3 USB 2.0 Connectors.....	52
3.3.4 USB 3.2 Gen 1 Connectors.....	52
4 INSTALLATION.....	54
4.1 ANTI-STATIC PRECAUTIONS.....	55
4.2 INSTALLATION CONSIDERATIONS.....	55
4.3 SO-DIMM INSTALLATION.....	57
4.4 FULL-SIZE PCIe MINI CARD INSTALLATION.....	57
4.5 HALF-SIZE PCIe MINI CARD INSTALLATION.....	59
4.6 M.2 MODULE INSTALLATION.....	61

NANO-AL EPIC SBC

4.7 SIM CARD INSTALLATION	63
4.8 SYSTEM CONFIGURATION.....	65
4.8.1 AT/ATX Power Mode Selection.....	65
4.8.2 Clear CMOS Button.....	66
4.8.3 HDMI/DP Selection Switch	66
4.8.4 LVDS Panel Type Selection.....	67
4.8.5 LVDS Voltage Selection	69
4.8.6 M.2 and SATA2 Selection Switch	70
4.8.7 Flash Descriptor Security Override Jumper.....	71
4.9 CHASSIS INSTALLATION.....	72
4.9.1 Airflow.....	72
4.9.2 Motherboard Installation.....	72
4.10 INTERNAL PERIPHERAL DEVICE CONNECTIONS.....	73
4.10.1 RS-232 Cable Connection.....	73
4.10.2 SATA Drive Connection	74
4.11 SOFTWARE INSTALLATION	75
4.11.1 Driver Download.....	75
5 BIOS.....	77
5.1 INTRODUCTION.....	78
5.1.1 Starting Setup.....	78
5.1.2 Using Setup	78
5.1.3 Getting Help.....	79
5.1.4 Unable to Reboot after Configuration Changes	79
5.1.5 BIOS Menu Bar.....	79
5.2 MAIN.....	80
5.3 ADVANCED.....	81
5.3.1 Trusted Computing.....	82
5.3.2 ACPI Settings.....	83
5.3.3 F81866 Super IO Configuration.....	84
5.3.3.1 Serial Port n Configuration.....	84
5.3.4 iWDD H/W Monitor.....	90
5.3.4.1 Smart Fan Mode Configuration	91
5.3.5 USB Configuration.....	92
5.3.6 CPU Configuration.....	93

5.3.7 RTC Wake Settings	95
5.3.8 Power Saving Configuration.....	96
5.3.9 Serial Port Console Redirection	97
5.3.9.1 Legacy Console Redirection Settings	100
5.3.10 IEI Feature.....	101
5.4 CHIPSET	102
5.4.1 North Bridge	102
5.4.1.1 Intel IGD Configuration.....	103
5.4.1.2 LCD Control	105
5.4.2 Southbridge Configuration	106
5.4.2.1 HD Audio Configuration.....	108
5.4.2.2 PCI Express Configuration	109
5.4.2.3 SATA Configuration.....	112
5.5 SECURITY.....	113
5.6 BOOT.....	114
5.7 SAVE & EXIT	116
A REGULATORY COMPLIANCE	117
B PRODUCT DISPOSAL	119
C BIOS OPTIONS	121
D DIGITAL I/O INTERFACE.....	124
E ERROR BEEP CODE.....	127
E.1 PEI BEEP CODES.....	128
E.2 DXE BEEP CODES	128
F HAZARDOUS MATERIALS DISCLOSURE.....	129
F.1 RoHS II DIRECTIVE (2015/863/EU)	130
F.2 CHINA ROHS.....	131

List of Figures

Figure 1-1: NANO-AL.....	2
Figure 1-2: Connectors (Front Side).....	4
Figure 1-3: Connectors (Solder Side).....	5
Figure 1-4: NANO-AL Dimensions (mm)	6
Figure 1-5: Data Flow Diagram.....	7
Figure 3-1: Peripheral Interface Connectors	16
Figure 3-2: 9 V ~ 30 V Power Connector Location	19
Figure 3-3: Audio Connector Location	20
Figure 3-4: Backlight Inverter Connector Location.....	21
Figure 3-5: Battery Connector Location.....	22
Figure 3-6: BIOS Debug Connector Location	23
Figure 3-7: Buzzer Connector Location	24
Figure 3-8: Chassis Intrusion Connector Location.....	25
Figure 3-9: CPU Fan Connector Location	26
Figure 3-10: Digital I/O Connector Location	27
Figure 3-11: EC Debug Connector Location.....	28
Figure 3-12: Front Panel Connector Location	29
Figure 3-13: I ² C Connector Location	30
Figure 3-14: Internal DisplayPort Connector Location	31
Figure 3-15: Keyboard and Mouse Connector Location.....	32
Figure 3-16: LAN LED Connector Locations	33
Figure 3-17: LVDS Connector Location.....	34
Figure 3-18: microSD Card Slot Location	36
Figure 3-19: M.2 Slot Location	37
Figure 3-20: PCIe Mini Card Slot Location.....	37
Figure 3-21: On-board Power Button Location	39
Figure 3-22: Power Button Connector Location.....	39
Figure 3-23: Reset Button Connector Location.....	40
Figure 3-24: SATA 6Gb/s Drive Connector Locations	41
Figure 3-25: 5 V SATA Power Connector Locations	42

Figure 3-26: RS-232 Serial Port Connector Locations.....	43
Figure 3-27: RS-232/422/485 Serial Port Connector Locations.....	44
Figure 3-28: SIM Card Slot Location.....	45
Figure 3-29: SMBus Connector Location.....	46
Figure 3-30: SO-DIMM Connector Location.....	47
Figure 3-31: SPI Flash Connector Location.....	47
Figure 3-32: EC SPI Flash Connector Location.....	48
Figure 3-33: USB 2.0 Connector Location.....	49
Figure 3-34: External Interface Connectors.....	50
Figure 3-35: HDMI Connector Pinout Locations.....	51
Figure 3-36: LAN Connector.....	51
Figure 4-1: SO-DIMM Installation.....	57
Figure 4-2: Removing the Retention Screw.....	58
Figure 4-3: Inserting the Full-size PCIe Mini Card into the Slot at an Angle.....	58
Figure 4-4: Securing the Full-size PCIe Mini Card.....	59
Figure 4-5: Installing the Standoff.....	60
Figure 4-6: Inserting the Half-size PCIe Mini Card into the Slot at an Angle.....	60
Figure 4-7: Securing the Half-size PCIe Mini Card.....	61
Figure 4-8: Removing the M.2 Module Retention Screw.....	62
Figure 4-9: Inserting the M.2 Module into the Slot at an Angle.....	62
Figure 4-10: Securing the M.2 Module.....	63
Figure 4-11: Unlock SIM Card Slot Cover.....	64
Figure 4-12: SIM Card Installation.....	64
Figure 4-13: Lock SIM Card Slot Cover.....	65
Figure 4-14: AT/ATX Power Mode Switch Location.....	65
Figure 4-15: Clear CMOS Button Location.....	66
Figure 4-16: HDMI/DP Selection Switch Location.....	67
Figure 4-17: LVDS Panel Type Selection Switch Location.....	68
Figure 4-18: LVDS Voltage Selection Jumper Location.....	69
Figure 4-19: M.2 and SATA2 Selection Switch Location.....	70
Figure 4-20: Flash Descriptor Security Override Jumper Location.....	71
Figure 4-21: Single RS-232 Cable Installation.....	73
Figure 4-22: SATA Drive Cable Connection.....	74
Figure 4-23: IEI Resource Download Center.....	75

List of Tables

Table 1-1: Model Variations	3
Table 1-2: Technical Specifications.....	10
Table 2-1: Packing List.....	13
Table 2-2: Optional Items	14
Table 3-1: Peripheral Interface Connectors	18
Table 3-2: Rear Panel Connectors	18
Table 3-3: 9 V ~ 30 V Power Connector Pinouts.....	19
Table 3-4: Audio Connector Pinouts	20
Table 3-5: Backlight Inverter Connector Pinouts	21
Table 3-6: Battery Connector Pinouts	22
Table 3-7: BIOS Debug Connector Pinouts	23
Table 3-8: Buzzer Connector Pinouts.....	24
Table 3-9: Chassis Intrusion Connector Pinouts	25
Table 3-10: CPU Fan Connector Pinouts	26
Table 3-11: Digital I/O Connector Pinouts.....	27
Table 3-12: EC Debug Connector Pinouts	28
Table 3-13: Front Panel Connector Pinouts.....	29
Table 3-14: I ² C Connector Pinouts.....	30
Table 3-15: Internal DisplayPort Connector Pinouts	32
Table 3-16: Keyboard and Mouse Connector Pinouts	33
Table 3-17: LAN LED Connector Pinouts	33
Table 3-18: LVDS Connector Pinouts.....	35
Table 3-19: PCIe Mini Card Slot Pinouts	38
Table 3-20: Power Button Connector Pinouts	40
Table 3-21: Reset Button Connector Pinouts	40
Table 3-22: SATA 6Gb/s Drive Connector Pinouts.....	41
Table 3-23: 5 V SATA Power Connector Pinouts	42
Table 3-24: RS-232 Serial Port Connector Pinouts	43
Table 3-25: RS-232/422/485 Serial Port Connector Pinouts	44
Table 3-26: DB-9 RS-232/422/485 Pinouts	45

Table 3-27: SMBus Connector Pinouts	46
Table 3-28: SPI Flash Connector Pinouts	48
Table 3-29: EC SPI Flash Connector Pinouts	48
Table 3-30: USB 2.0 Connector Pinouts	49
Table 3-31: HDMI Connector Pinouts	50
Table 3-32: LAN Pinouts	52
Table 3-33: USB 2.0 Port Pinouts	52
Table 3-34: USB 3.2 Gen 1 Port Pinouts	53
Table 4-1: AT/ATX Power Mode Switch Settings	66
Table 4-2: HDMI/DP Selection Switch Settings	67
Table 4-3: LVDS Panel Type Selection	68
Table 4-4: LVDS Voltage Selection Jumper Settings	69
Table 4-5: M.2 and SATA2 Selection Switch Settings	70
Table 4-6: Flash Descriptor Security Override Jumper Settings	71
Table 5-1: BIOS Navigation Keys	79
Table 5-2: BIOS Options and Configured USB Ports	107

BIOS Menus

BIOS Menu 1: Main	80
BIOS Menu 2: Advanced	81
BIOS Menu 3: Trusted Computing	82
BIOS Menu 4: ACPI Settings	83
BIOS Menu 5: F81866 Super IO Configuration	84
BIOS Menu 6: Serial Port n Configuration Menu	84
BIOS Menu 7: iWDD H/W Monitor	90
BIOS Menu 8: Smart Fan Mode Configuration	91
BIOS Menu 9: USB Configuration	92
BIOS Menu 10: CPU Configuration	93
BIOS Menu 11: RTC Wake Settings	95
BIOS Menu 12: Power Saving Configuration	96
BIOS Menu 13: Serial Port Console Redirection	97
BIOS Menu 14: Legacy Console Redirection Settings	100
BIOS Menu 15: IEI Feature	101
BIOS Menu 16: Chipset	102
BIOS Menu 17: North Bridge	102
BIOS Menu 18: Intel IGD Configuration	103
BIOS Menu 19: LCD Control	105
BIOS Menu 20: Southbridge Configuration	106
BIOS Menu 21: HD-Audio Configuration	108
BIOS Menu 22: PCI Express Configuration	109
BIOS Menu 23: Onboard LAN1/Onboard LAN2 Configuration	110
BIOS Menu 24: MPCIE1 Configuration	111
BIOS Menu 25: SATA Configuration	112
BIOS Menu 26: Security	113
BIOS Menu 27: Boot	114
BIOS Menu 28: Save & Exit	116

Chapter

1

Introduction

1.1 Introduction

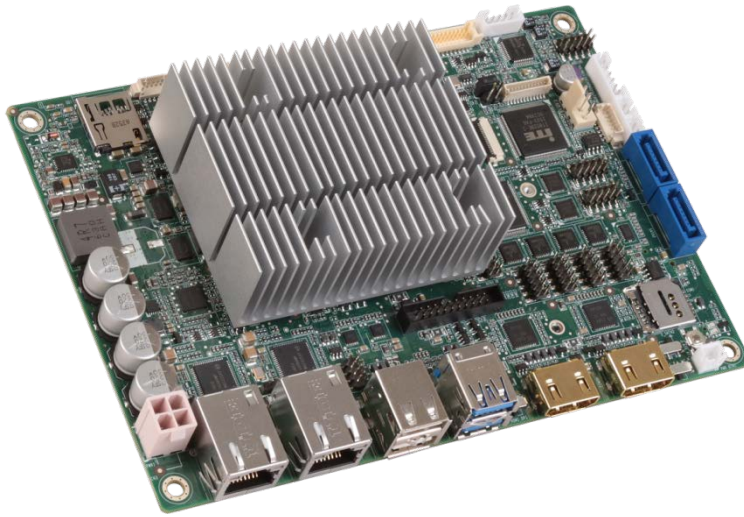

Figure 1-1: NANO-AL

The NANO-AL is an EPIC form factor single board computer. It has an on-board 14nm Intel® Pentium®/Celeron®/Atom® SoC, and supports one 204-pin 1866/1600 MHz DDR3L SDRAM SO-DIMM with up to 8 GB of memory.

The NANO-AL provides two GbE interfaces through the Intel® I211-AT PCIe GbE controllers. In addition, the NANO-AL comes with two HDMI, one internal DisplayPort and one 18-bit/24-bit dual-channel LVDS connector for triple independent display.

Expansion and I/O include two USB 3.2 Gen 1 (5Gb/s) and two USB 2.0 on the rear panel, two USB 2.0 by pin header, two SATA 6Gb/s, four RS-232, two RS-232/422/485, one microSD card slot (optional), one SIM card slot (optional), one PCIe Mini card slot and one M.2 slot. High Definition Audio (HDA) support ensures HDA devices can be easily implemented on the NANO-AL.

NANO-AL EPIC SBC

1.2 Model Variations

The model variations for the NANO-AL series are listed in **Table 1-1**.

Model	On-board SoC	Operating Temp.
NANO-AL-N2	Intel® Pentium® N4200 on-board SoC (up to 2.5 GHz, quad-core, 2 MB cache, TDP=6 W)	-20°C ~ 70°C
NANO-AL-N1	Intel® Celeron® N3350 on-board SoC (up to 2.4 GHz, dual-core, 2 MB cache, TDP=6 W)	-20°C ~ 70°C
NANO-AL-E1W2*	Intel® Atom® x5-E3930 on-board SoC (up to 1.8 GHz, dual-core, 2 MB cache, TDP=6 W)	-40°C ~ 85°C
NANO-AL-E2W2*	Intel® Atom® x5-E3940 on-board SoC (up to 1.8 GHz, quad-core, 2 MB cache, TDP=9 W)	-40°C ~ 85°C
NANO-AL-E3W2*	Intel® Atom® x7-E3950 on-board SoC (up to 2.0 GHz, quad-core, 2 MB cache, TDP=12 W)	-40°C ~ 85°C
*Production by order, MOQ 100 pcs/lot		

Table 1-1: Model Variations

1.3 Features

Some of the NANO-AL motherboard features are listed below:

- EPIC form factor
- On-board 14nm Intel® Pentium®/Celeron®/Atom® SoC
- One 204-pin 1866/1600 MHz DDR3L SDRAM SO-DIMM slot supports up to 8 GB
- Wide-range 9 V ~ 30 V power input design
- Supports triple independent display
- Complete I/O interfaces, including two USB 3.2 Gen 1 (5Gb/s), four USB 2.0, four RS-232, two RS-232/422/485 and two SATA 6Gb/s
- Flexible expansion options, including one PCIe Mini card slot, one SIM card slot (optional), one microSD card slot (optional) and one M.2 slot
- Supports wide-range operating temperature: -40°C ~ 85°C
- RoHS compliant

1.4 Connectors

The connectors on the NANO-AL are shown in the following figures.

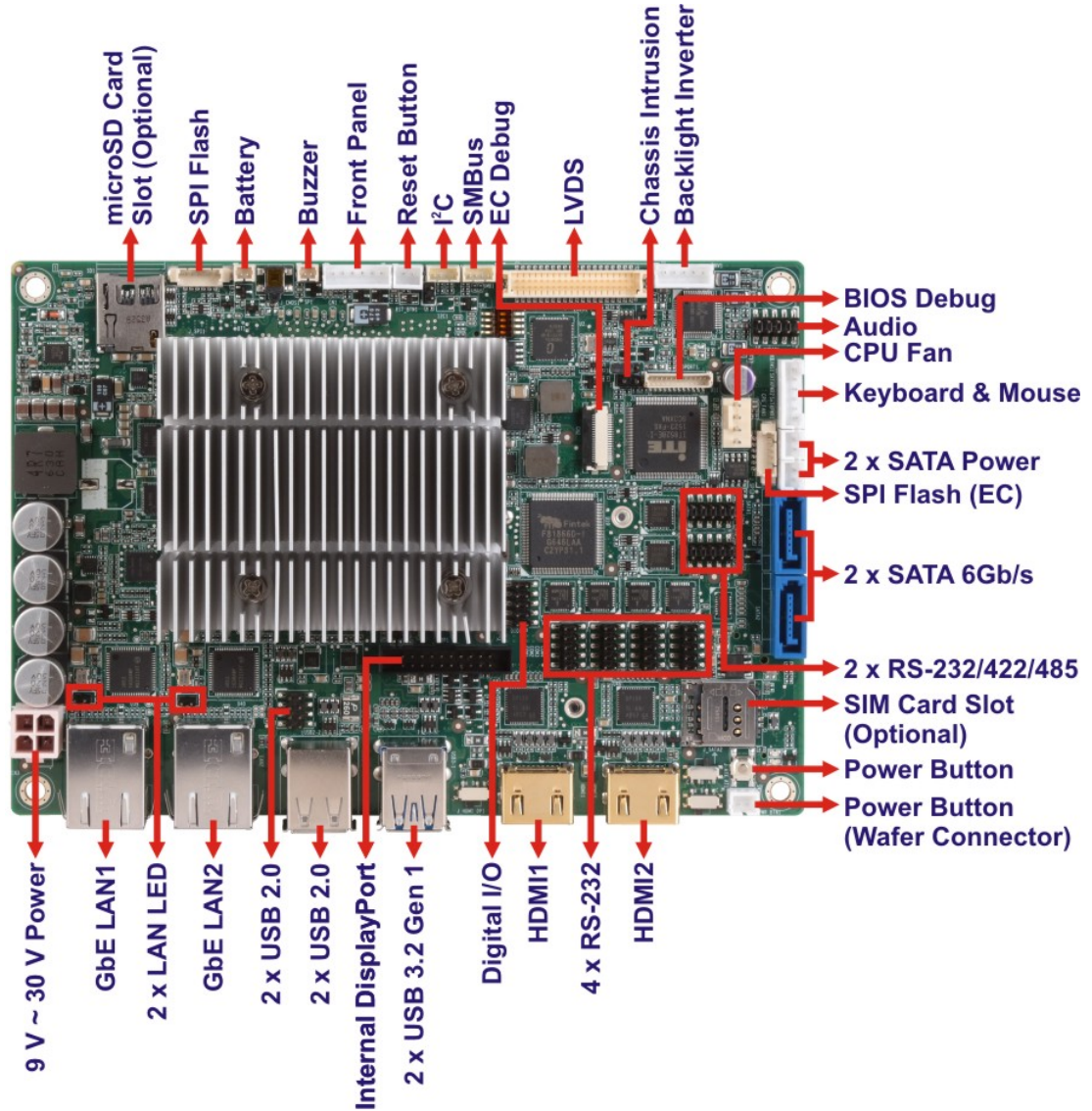

Figure 1-2: Connectors (Front Side)

NANO-AL EPIC SBC

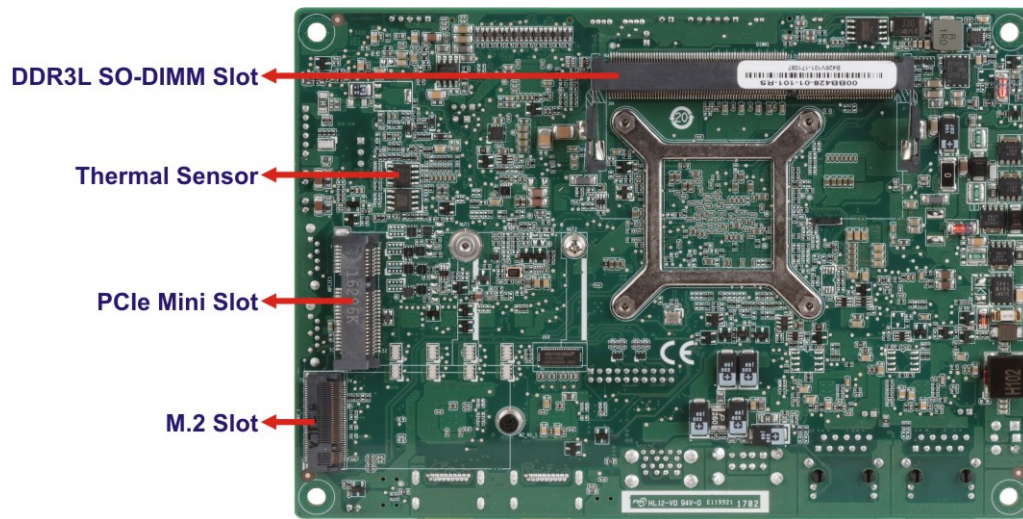

Figure 1-3: Connectors (Solder Side)

1.5 Dimensions

The main dimensions of the NANO-AL are shown in the diagram below.

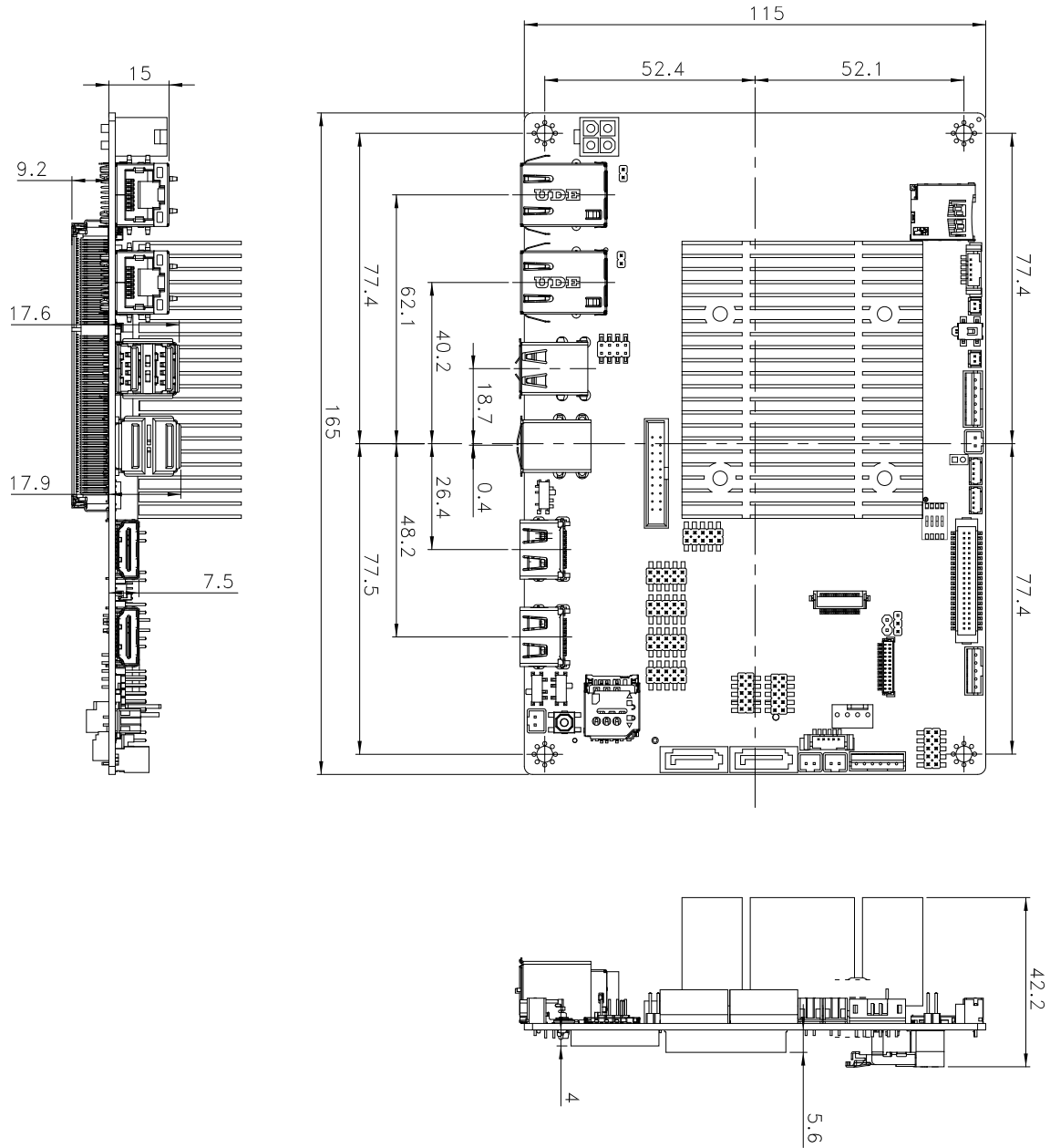

Figure 1-4: NANO-AL Dimensions (mm)

NANO-AL EPIC SBC

1.6 Data Flow

Figure 1-5 shows the data flow between the system chipset, the SoC and other components installed on the motherboard.

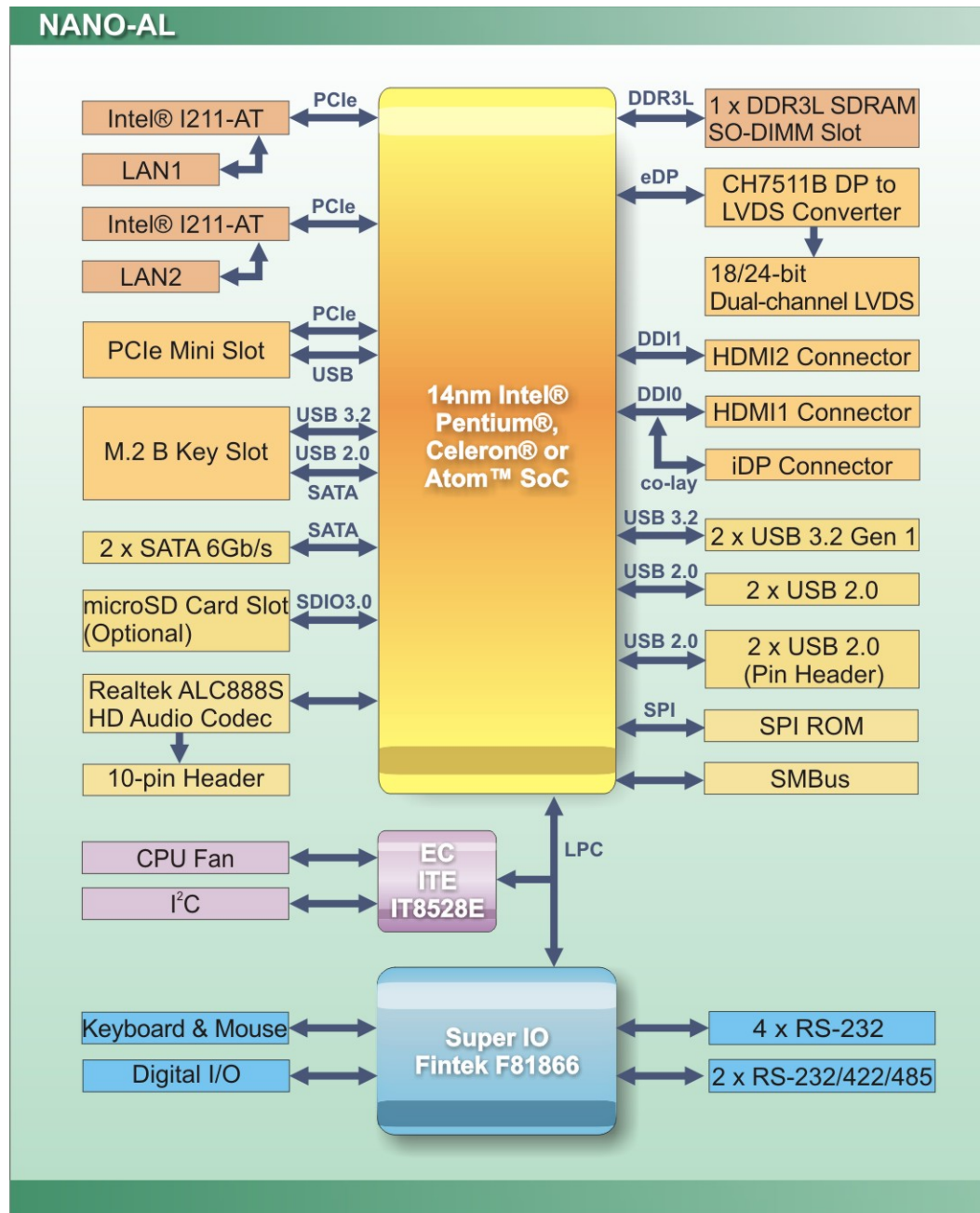

Figure 1-5: Data Flow Diagram

1.7 Technical Specifications

The NANO-AL technical specifications are listed in **Table 1-2**.

Form Factor	EPIC
Onboard SoC	<p>Standard:</p> <p>Intel® Pentium® N4200 on-board SoC (up to 2.5 GHz, quad-core, 2 MB cache, TDP=6 W)</p> <p>Intel® Celeron® N3350 on-board SoC (up to 2.4 GHz, dual-core, 2 MB cache, TDP=6 W)</p> <p>Production by order (MOQ 100):</p> <p>Intel® Atom® x5-E3930 on-board SoC (up to 1.8 GHz, dual-core, 2 MB cache, TDP=6 W)</p> <p>Intel® Atom® x5-E3940 on-board SoC (up to 1.8 GHz, quad-core, 2 MB cache, TDP=9 W)</p> <p>Intel® Atom® x7-E3950 on-board SoC (up to 2.0 GHz, quad-core, 2 MB cache, TDP=12 W)</p>
Memory	One 204-pin 1866/1600 MHz DDR3L SDRAM SO-DIMM slot supports up to 8 GB
Graphics Engine	Intel® HD Graphics Gen 9 with 18 execution units 4K codec decode & encode for HEVC 4, H.264, VP8, SVC and MVC
Display Output	Supports triple independent display Two HDMI (up to 3840x2160@30 Hz) One 18/24-bit dual-channel LVDS (up to 1920x1200@60 Hz) One iDP interface for HDMI, VGA, DVI and DisplayPort (up to 1920x1200@60 Hz, co-lay with HDMI1)
BIOS	AMI UEFI BIOS
Ethernet	Dual Intel® I211-AT PCIe GbE controller
Audio	Realtek ALC888S HD codec
Super I/O Controller	Fintek F81866
Watchdog Timer	Software programmable, supports 1~255 sec. system reset

NANO-AL EPIC SBC

Expansions	<p>One full-size/half-size PCIe Mini card slot (with optional SIM card holder)</p> <p>1 x M.2 2242 slot (B key, SATA, USB 2.0, USB 3.2 Gen 1 signal only)</p> <p>One microSD card slot (optional)</p>
I/O Interfaces	
Audio Connector	One front panel audio connector (10-pin header)
Chassis Intrusion	One 2-pin header
Digital I/O	One 8-bit digital I/O
Ethernet	Two RJ-45 GbE ports
Fan Connector	One smart fan connector by 4-pin wafer
Front Panel	<p>One 6-pin wafer connector for power LED and HDD LED</p> <p>One 2-pin wafer connector for power button</p> <p>One 2-pin wafer connector for reset button</p>
I²C	One 4-pin wafer connector
Keyboard and Mouse	One 6-pin wafer connector for PS/2 keyboard and mouse
LAN LEDs	Two 2-pin headers for LAN1 LED and LAN2 LED (link signal)
Serial ATA	<p>Two SATA 6Gb/s connectors (no RAID)</p> <p>Two 5 V SATA power connectors</p>
Serial Ports	<p>Four RS-232 by internal 10-pin headers</p> <p>Two RS-232/422/485 by internal 10-pin headers</p>
SMBus	One 4-pin wafer connector
USB Ports	<p>Two USB 3.2 Gen 1 (5Gb/s) ports on rear panel</p> <p>Four USB 2.0 ports (two on rear panel, two by pin headers)</p>
Environmental and Power Specifications	
Power Supply	<p>9 V ~ 30 V DC input</p> <p>One internal 4-pin (2x2) power connector</p> <p>Supports AT/ATX mode</p>

Power Consumption	12V@2.13A (Intel® Pentium® N4200 SoC with one 8 GB 1600 MHz DDR3L memory) 12V@2.81A (Intel® Atom® x7-E3950 SoC with one 8 GB 1600 MHz DDR3L memory)
Operating Temperature	-20°C ~ 70°C (NANO-AL-Nx) -40°C ~ 85°C (NANO-AL-ExW2)
Storage Temperature	-40°C ~ 85°C
Operating Humidity	5% ~ 95% (non-condensing)
Physical Specifications	
Dimensions	115 mm x 165 mm
Weight (GW/NW)	850 g/350 g

Table 1-2: Technical Specifications

Chapter

2

Packing List

2.1 Anti-static Precautions



WARNING!

Static electricity can destroy certain electronics. Make sure to follow the ESD precautions to prevent damage to the product, and injury to the user.

Make sure to adhere to the following guidelines:

- **Wear an anti-static wristband:** Wearing an anti-static wristband can prevent electrostatic discharge.
- **Self-grounding:** Touch a grounded conductor every few minutes to discharge any excess static buildup.
- **Use an anti-static pad:** When configuring any circuit board, place it on an anti-static mat.
- **Only handle the edges of the PCB:** Don't touch the surface of the motherboard. Hold the motherboard by the edges when handling.

2.2 Unpacking Precautions

When the NANO-AL is unpacked, please do the following:

- Follow the anti-static guidelines above.
- Make sure the packing box is facing upwards when opening.
- Make sure all the packing list items are present.

NANO-AL EPIC SBC

2.3 Packing List



NOTE:

If any of the components listed in the checklist below are missing, do not proceed with the installation. Contact the IEI reseller or vendor the NANO-AL was purchased from or contact an IEI sales representative directly by sending an email to sales@ieiworld.com.

The NANO-AL is shipped with the following components:







Quantity	Item and Part Number	Image
1	NANO-AL SBC	
1	SATA signal and power cable	
1	RS-232 cable	
1	Power cable	
1	Standoff and screw (for half-size PCIe Mini card)	
1	Quick installation guide	

Table 2-1: Packing List

2.4 Optional Items

The following are optional components which may be separately purchased:







Item and Part Number	Image
Dual-port USB cable, 210 mm, P=2.0 (P/N: 32000-070301-RS)	
PS/2 keyboard and mouse Y cable, 155mm/130mm, P=2.0 (P/N: 32006-001100-201-RS)	
DisplayPort to HDMI converter board (for IEI iDP connector) (P/N: DP-HDMI-R10)	
DisplayPort to VGA converter board (for IEI iDP connector) (P/N: DP-VGA-R10)	
DisplayPort to DVI-D converter board (for IEI iDP connector) (P/N: DP-DVI-R10)	
DisplayPort to DisplayPort converter board (for IEI iDP connector) (P/N: DP-DP-R10)	

Table 2-2: Optional Items

Chapter

3

Connectors

3.1 Peripheral Interface Connectors

This chapter details all the peripheral interface connectors.

3.1.1 Layout

The figures below show all the peripheral interface connectors.

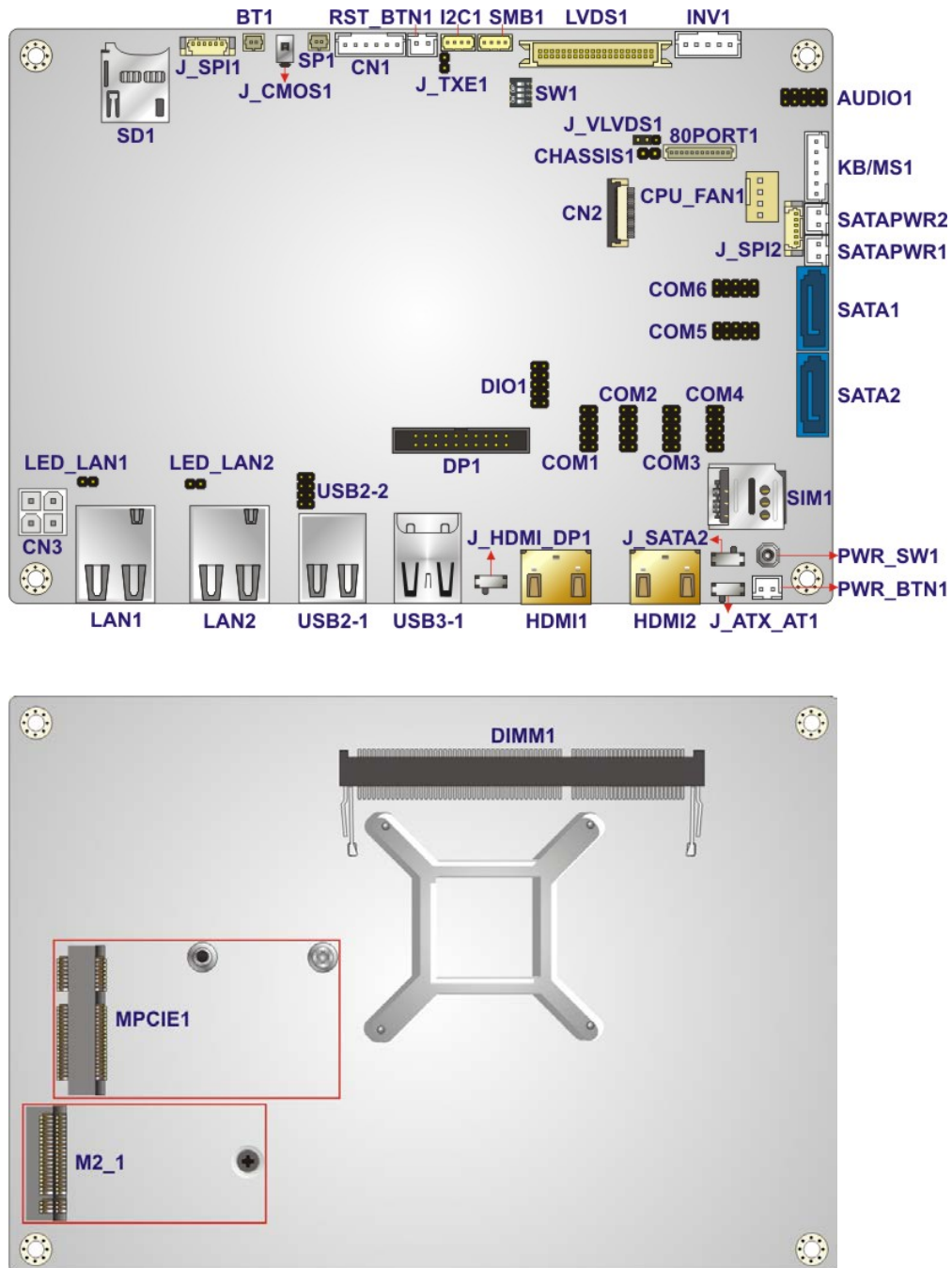

Figure 3-1: Peripheral Interface Connectors

NANO-AL EPIC SBC

3.1.2 Peripheral Interface Connectors

The table below shows a list of the peripheral interface connectors on the NANO-AL. Detailed descriptions of these connectors can be found below.

Connector	Type	Label
9 V ~ 30 V power connector	4-pin Molex power connector	CN3
Audio connector	10-pin header	AUDIO1
Backlight inverter	5-pin wafer	INV1
Battery connector	2-pin wafer	BT1
BIOS debug connector	12-pin wafer	80PORT1
Buzzer connector	2-pin wafer	SP1
Chassis intrusion connector	2-pin header	CHASSIS1
CPU fan connector	4-pin wafer	CPU_FAN1
Digital I/O connector	10-pin header	DIO1
EC debug connector	20-pin wafer	CN2
Front panel connector	6-pin wafer	CN1
I ² C connector	4-pin wafer	I2C1
Internal DisplayPort connector	20-pin box header	DP1
Keyboard and mouse connector	6-pin wafer	KB/MS1
LAN LED connectors	2-pin header	LED_LAN1, LED_LAN2
LVDS connector	40-pin crimp	LVDS1
microSD card slot	microSD card slot	SD1
M.2 slot	M.2 2242 slot, B-key	M2_1
PCIe Mini card slot	PCIe Mini card slot	MPCIE1
Power button (on-board)	Push button	PWR_SW1
Power button connector	2-pin wafer	PWR_BTN1
Reset button connector	2-pin wafer	RST_BTN1

Connector	Type	Label
SATA 6Gb/s connectors	7-pin SATA connector	SATA1, SATA2
SATA power connectors (5 V)	2-pin wafer	SATAPWR1, SATAPWR2
Serial ports, RS-232	10-pin header	COM1, COM2, COM3, COM4
Serial port, RS-232/422/485	10-pin header	COM5, COM6
SIM card slot (optional)	micro-SIM card slot	SIM1
SMBus connector	4-pin wafer	SMB1
SO-DIMM connector	204-pin DDR3L SO-DIMM connector	DIMM1
SPI flash connector	6-pin wafer	J_SPI1
SPI flash connector (EC)	6-pin wafer	J_SPI2
USB 2.0 connector	8-pin header	USB2-2

Table 3-1: Peripheral Interface Connectors

3.1.3 External Interface Panel Connectors

The table below lists the rear panel connectors on the NANO-AL. Detailed descriptions of these connectors can be found in a later section.

Connector	Type	Label
HDMI connectors	HDMI	HDMI1, HDMI2
LAN connectors	RJ-45	LAN1, LAN2
USB 2.0 connectors	USB Type-A	USB2-1
USB 3.2 Gen 1 connectors	USB Type-A	USB3-1

Table 3-2: Rear Panel Connectors

NANO-AL EPIC SBC

3.2 Internal Peripheral Connectors

Internal peripheral connectors are found on the motherboard and are only accessible when the motherboard is outside of the chassis. This section has complete descriptions of all the internal, peripheral connectors on the NANO-AL.

3.2.1 9 V ~ 30 V Power Connector

- CN Label:** CN3
- CN Type:** 4-pin Molex, p=4.2 mm
- CN Location:** See **Figure 3-2**
- CN Pinouts:** See **Table 3-3**

This connector provides power to the system.

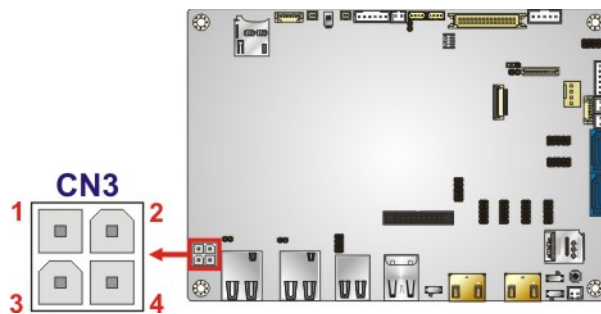

Figure 3-2: 9 V ~ 30 V Power Connector Location

Pin	Description	Pin	Description
1	GND	2	GND
3	Power (9 V ~ 30 V)	4	Power (9 V ~ 30 V)

Table 3-3: 9 V ~ 30 V Power Connector Pinouts

3.2.2 Audio Connector

- CN Label:** AUDIO1
- CN Type:** 10-pin header, p=2 mm
- CN Location:** See **Figure 3-3**
- CN Pinouts:** See **Table 3-4**

This connector connects to speakers, a microphone and an audio input.

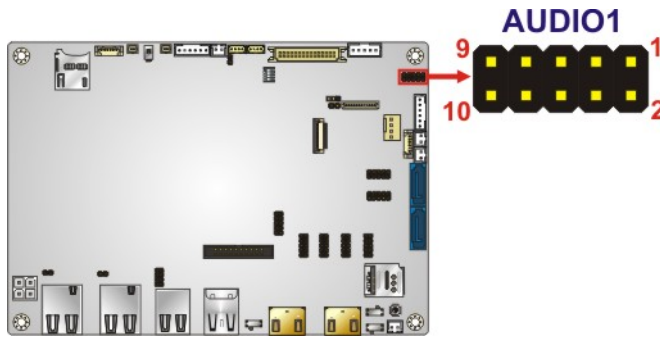

Figure 3-3: Audio Connector Location

Pin	Description	Pin	Description
1	LINE_OUTR	2	LINEIN_R
3	ANALOG_GND	4	ANALOG_GND
5	LINE_OUTL	6	LINEIN_L
7	ANALOG_GND	8	ANALOG_GND
9	MICIN1	10	MICIN2

Table 3-4: Audio Connector Pinouts

3.2.3 Backlight Inverter Connector

- CN Label:** INV1
- CN Type:** 5-pin wafer, p=2 mm
- CN Location:** See **Figure 3-4**
- CN Pinouts:** See **Table 3-5**

The backlight inverter connector provides power to an LCD panel.

NANO-AL EPIC SBC

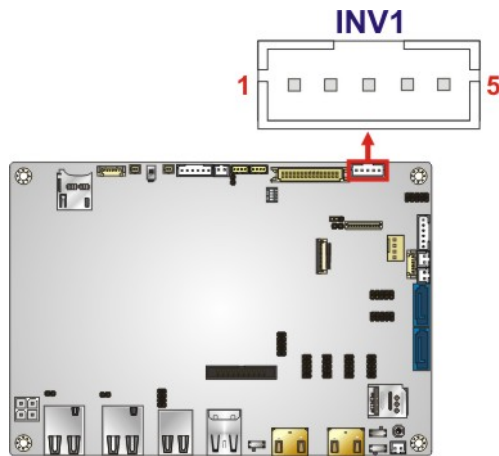

Figure 3-4: Backlight Inverter Connector Location

Pin	Description
1	LCD_BKLTCTL
2	GROUND
3	+ 12V
4	GROUND
5	BACKLIGHT ENABLE

Table 3-5: Backlight Inverter Connector Pinouts

3.2.4 Battery Connector



CAUTION:

Risk of explosion if battery is replaced by an incorrect type. Only certified engineers should replace the on-board battery.

Dispose of used batteries according to instructions and local regulations.



NOTE:

It is recommended to attach the RTC battery onto the system chassis in which the NANO-AL is installed.

- CN Label:** BT1
- CN Type:** 2-pin wafer, p=1.25 mm
- CN Location:** See **Figure 3-5**
- CN Pinouts:** See **Table 3-6**

This is connected to the system battery. The battery provides power to the system clock to retain the time when power is turned off.

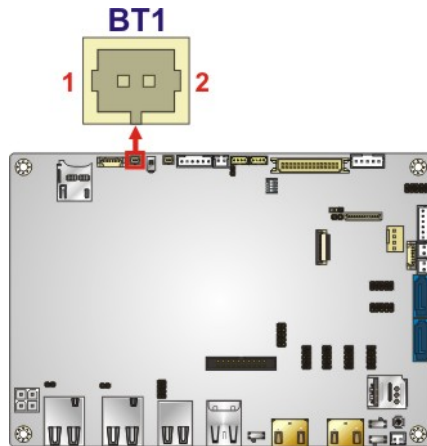

Figure 3-5: Battery Connector Location

Pin	Description
1	VBATT
2	GND

Table 3-6: Battery Connector Pinouts

NANO-AL EPIC SBC

3.2.5 BIOS Debug Connector

- CN Label:** 80PORT1
- CN Type:** 12-pin wafer, p=1 mm
- CN Location:** See **Figure 3-6**
- CN Pinouts:** See **Table 3-7**

This connector is used for BIOS debug.

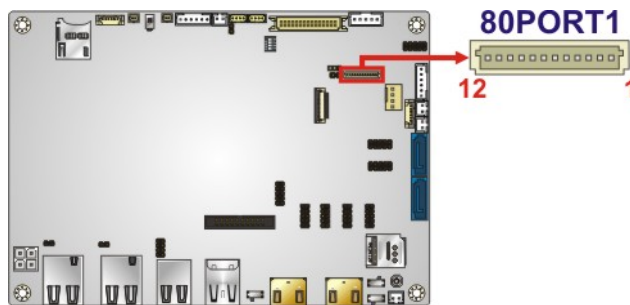

Figure 3-6: BIOS Debug Connector Location

Pin	Description	Pin	Description
1	KS10	11	KSO9
2	KSO0	12	KSO10
3	KSO1	13	KSO12
4	KSO2	14	KS11
5	KSO3	15	KSO11
6	KSO4	16	KS12
7	KSO5	17	KS13
8	KSO6	18	GND
9	KSO7	19	GND
10	KSO8	20	GND

Table 3-7: BIOS Debug Connector Pinouts

3.2.6 Buzzer Connector

- CN Label:** SP1
- CN Type:** 2-pin wafer, p=1.25 mm
- CN Location:** See **Figure 3-7**
- CN Pinouts:** See **Table 3-8**

Use this connector to connect a buzzer.

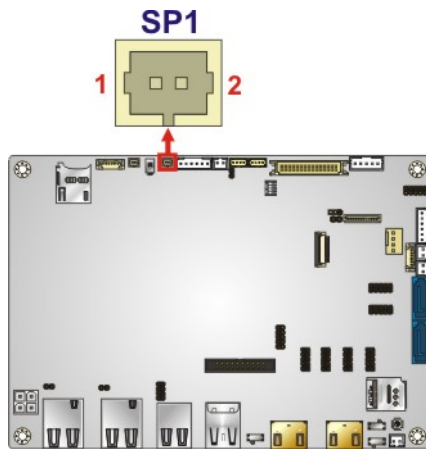

Figure 3-7: Buzzer Connector Location

Pin	Description
1	V5_S
2	GND

Table 3-8: Buzzer Connector Pinouts



NOTE:

If you cannot find a good place to put a buzzer on the NANO-AL, it is recommended to attach the buzzer onto the system chassis in which the NANO-AL is installed.

NANO-AL EPIC SBC

3.2.7 Chassis Intrusion Connector

- CN Label:** CHASSIS1
- CN Type:** 2-pin header, p=2.54 mm
- CN Location:** See **Figure 3-8**
- CN Pinouts:** See **Table 3-9**

The chassis intrusion connector is for a chassis intrusion detection sensor or switch that detects if a chassis component is removed or replaced.

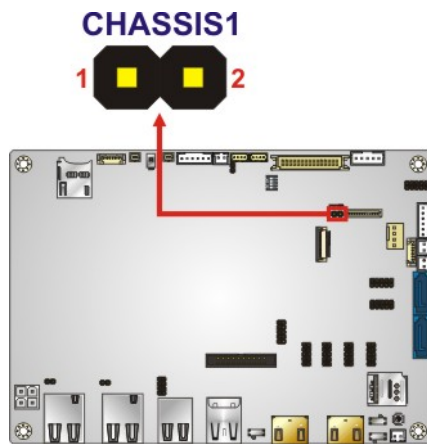

Figure 3-8: Chassis Intrusion Connector Location

Pin	Description
1	CHASSIS OPEN
2	GND

Table 3-9: Chassis Intrusion Connector Pinouts

3.2.8 CPU Fan Connector

- CN Label:** CPU_FAN1
- CN Type:** 4-pin wafer, p=2.54 mm
- CN Location:** See **Figure 3-9**
- CN Pinouts:** See **Table 3-10**

The fan connector attaches to a CPU cooling fan.

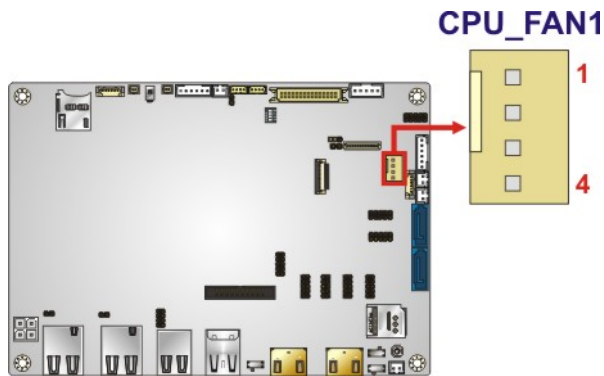

Figure 3-9: CPU Fan Connector Location

Pin	Description
1	GND
2	+12V
3	FANIO
4	PWM

Table 3-10: CPU Fan Connector Pinouts

NANO-AL EPIC SBC

3.2.9 Digital I/O Connector

- CN Label:** DIO1
- CN Type:** 10-pin header, p=2 mm
- CN Location:** See **Figure 3-10**
- CN Pinouts:** See **Table 3-11**

The digital I/O connector provides programmable input and output for external devices.

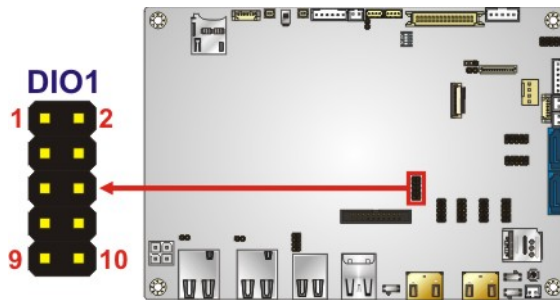

Figure 3-10: Digital I/O Connector Location

Pin	Description	Pin	Description
1	GND	2	+V5S
3	Output 3	4	Output 2
5	Output 1	6	Output 0
7	Input 3	8	Input 2
9	Input 1	10	Input 0

Table 3-11: Digital I/O Connector Pinouts

3.2.10 EC Debug Connector

- CN Label:** CN2
- CN Type:** 20-pin wafer, p=0.5 mm
- CN Location:** See **Figure 3-11**
- CN Pinouts:** See **Table 3-12**

The EC debug connector is used for EC debug.

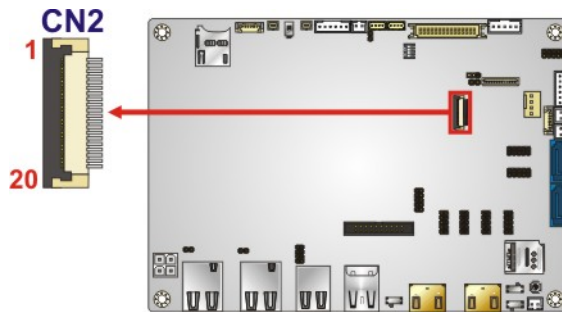

Figure 3-11: EC Debug Connector Location

Pin	Description	Pin	Description
1	KS10	11	KSO9
2	KSO0	12	KSO10
3	KSO1	13	KSO12
4	KSO2	14	KS11
5	KSO3	15	KSO11
6	KSO4	16	KS12
7	KSO5	17	KS13
8	KSO6	18	GND
9	KSO7	19	GND
10	KSO8	20	GND

Table 3-12: EC Debug Connector Pinouts

NANO-AL EPIC SBC

3.2.11 Front Panel Connector

- CN Label:** CN1
- CN Type:** 6-pin wafer, p=2 mm
- CN Location:** See **Figure 3-12**
- CN Pinouts:** See **Table 3-13**

The front panel connector connects to the indicator LEDs on the computer's front panel.

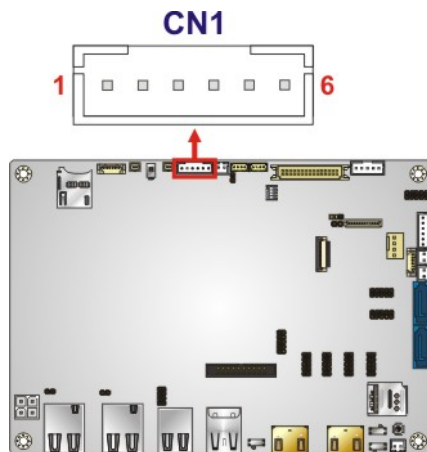

Figure 3-12: Front Panel Connector Location

Pin	Description
1	VCC
2	GND
3	PWR_LED+
4	PWR_LED-
5	HDD_LED+
6	HDD_LED-

Table 3-13: Front Panel Connector Pinouts

3.2.12 I²C Connector

- CN Label:** I2C1
- CN Type:** 4-pin wafer, p=1.25 mm
- CN Location:** See **Figure 3-13**
- CN Pinouts:** See **Table 3-14**

The I²C connector is used to connect I²C-bus devices to the motherboard.

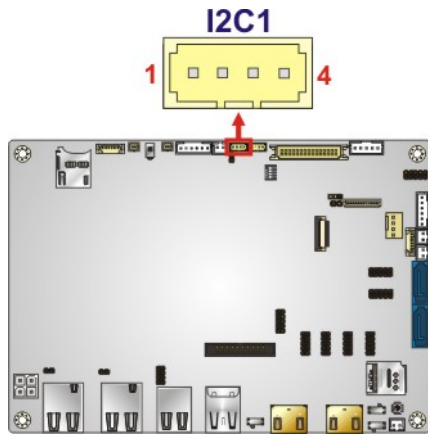

Figure 3-13: I²C Connector Location

Pin	Description
1	GND
2	I2C_DATA
3	I2C_CLK
4	VCC5V

Table 3-14: I²C Connector Pinouts

NANO-AL EPIC SBC

3.2.13 Internal DisplayPort Connector



NOTE:

The user can select either to use the HDMI1 connector or the internal DisplayPort connector. Use the HDMI1/DP selection switch to configure the settings. Please refer to **Section 4.8.3** for detailed information.

CN Label:	DP1
CN Type:	20-pin box header, $p=2.00$ mm
CN Location:	See Figure 3-14
CN Pinouts:	See Table 3-15

The internal DisplayPort connector supports HDMI, LVDS, VGA, DVI and DisplayPort graphics interfaces.

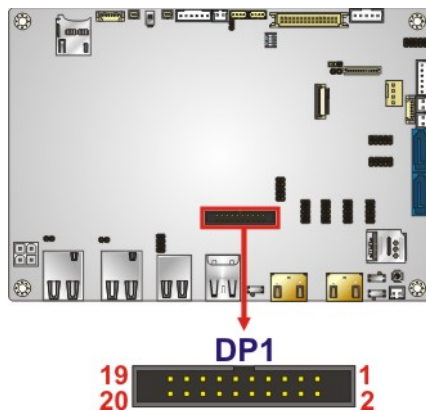

Figure 3-14: Internal DisplayPort Connector Location

Pin	Description	Pin	Description
1	HPD	2	AUX_P
3	GND	4	AUX_N
5	CAD	6	GND
7	GND	8	LANE2P
9	LANE3P	10	LANE2N
11	LANE3N	12	GND
13	GND	14	LANE0P
15	LANE1P	16	LANE0N
17	LANE1N	18	VCC3V
19	VCC5V	20	NC

Table 3-15: Internal DisplayPort Connector Pinouts

3.2.14 Keyboard and Mouse Connector

- CN Label:** KB/MS1
- CN Type:** 6-pin wafer, p=2 mm
- CN Location:** See Figure 3-15
- CN Pinouts:** See Table 3-16

The keyboard and mouse connector connects to a PS/2 Y-cable that can be connected to a PS/2 keyboard and mouse.

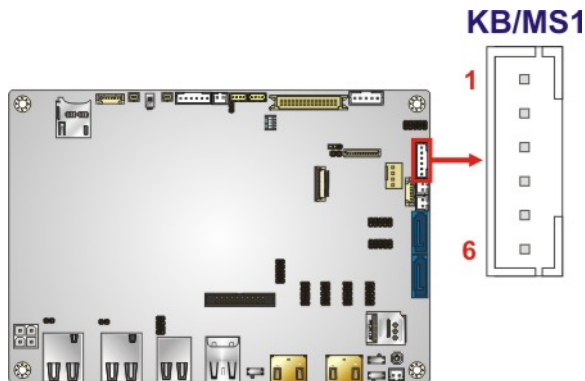

Figure 3-15: Keyboard and Mouse Connector Location

NANO-AL EPIC SBC

Pin	Description
1	VCC5_KBMS
2	Mouse Data
3	Mouse Clock
4	Keyboard Data
5	Keyboard Clock
6	GND

Table 3-16: Keyboard and Mouse Connector Pinouts

3.2.15 LAN LED Connectors

CN Label: LED_LAN1, LED_LAN2

CN Type: 2-pin header, p=2 mm

CN Location: See **Figure 3-16**

CN Pinouts: See **Table 3-17**

The LAN LED connectors are used to connect to the LAN LED indicators on the chassis to indicate users the link activities of the two LAN ports.

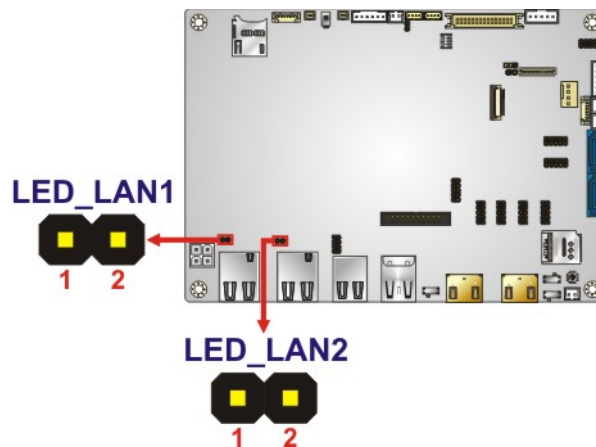

Figure 3-16: LAN LED Connector Locations

Pin	Description
1	+3.3V
2	LAN1_LED_LNK#_ACT

Table 3-17: LAN LED Connector Pinouts

3.2.16 LVDS Connector



CAUTION:

Pin 33 on the LVDS cable must be **GROUND**; otherwise the system will not display through LVDS even the LVDS cable is connected to the NANO-AL.

- CN Label:** LVDS1
- CN Type:** 40-pin crimp, p=1.25 mm
- CN Location:** See **Figure 3-17**
- CN Pinouts:** See **Table 3-18**

The LVDS connector is for the LCD panel connected to the board.

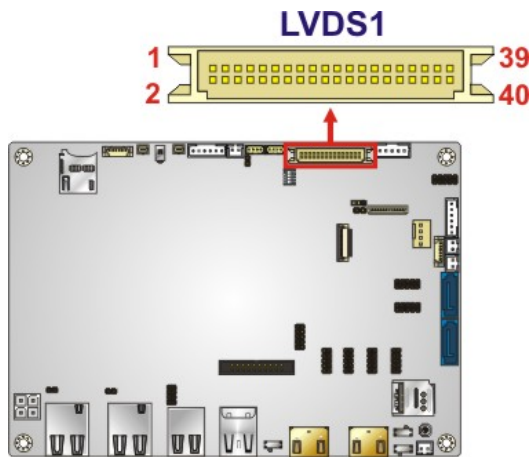

Figure 3-17: LVDS Connector Location

NANO-AL EPIC SBC

Pin	Description	Pin	Description
1	GND	2	GND
3	A_Y0#	4	A_Y1#
5	A_Y0	6	A_Y1
7	GND	8	GND
9	A_Y2#	10	A_CK#
11	A_Y2	12	A_CK
13	GND	14	GND
15	A_Y3#	16	B_Y0#
17	A_Y3	18	B_Y0
19	GND	20	GND
21	B_Y1#	22	B_Y2#
23	B_Y1	24	B_Y2
25	GND	26	GND
27	B_CK#	28	B_Y3#
29	B_CK	30	B_Y3
31	GND	32	GND
33	LVDS Detect (GND)*	34	GND
35	LVDS_VCC	36	LVDS_VCC
37	LVDS_VCC	38	LVDS_VCC
39	LVDS_VCC	40	LVDS_VCC

*LVDS Detect must be connected to GND.

Table 3-18: LVDS Connector Pinouts

3.2.17 microSD Card Slot (Optional)

CN Label:	SD1
CN Type:	microSD card slot
CN Location:	See Figure 3-18

The microSD card slot is for installing a microSD card to the system.

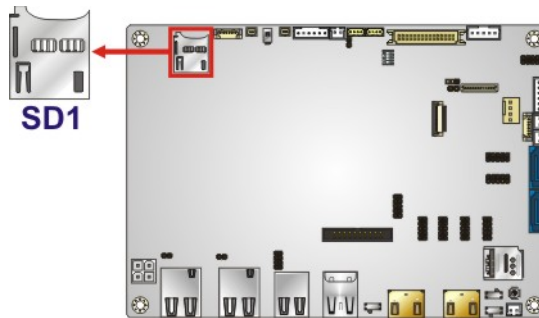

Figure 3-18: microSD Card Slot Location

3.2.18 M.2 Slot

CN Label:	M2_1
CN Type:	M.2 B-key slot
CN Location:	See Figure 3-19

The M.2 slot is keyed in the B position and provides the mounting screw position for 2242-size M.2 module. The M.2 slot supports the signals of SATA, USB 2.0 and USB 3.2 Gen 1 (reserved).



NOTE:

To use the SATA signal of the M.2 slot (**M2_1**), the user has to set the M.2 and SATA2 selection switch to B-C position. Please refer to **Section 4.8.6** for detail information.

NANO-AL EPIC SBC

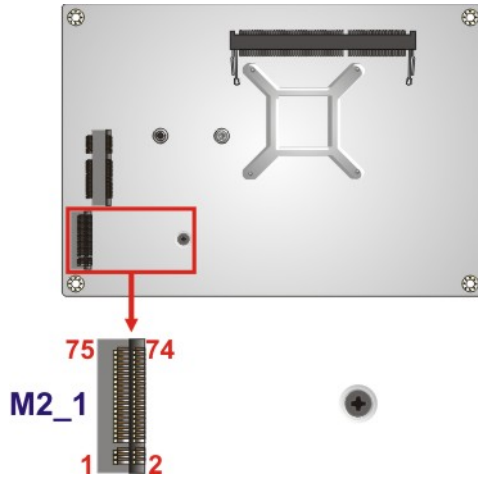

Figure 3-19: M.2 Slot Location

3.2.19 PCIe Mini Card Slot

- CN Label:** MPCIE1
- CN Type:** PCIe Mini card slot
- CN Location:** See **Figure 3-20**
- CN Pinouts:** See **Table 3-19**

The PCIe Mini card slot enables a full-size/half-size PCIe Mini card expansion module to be connected to the board.

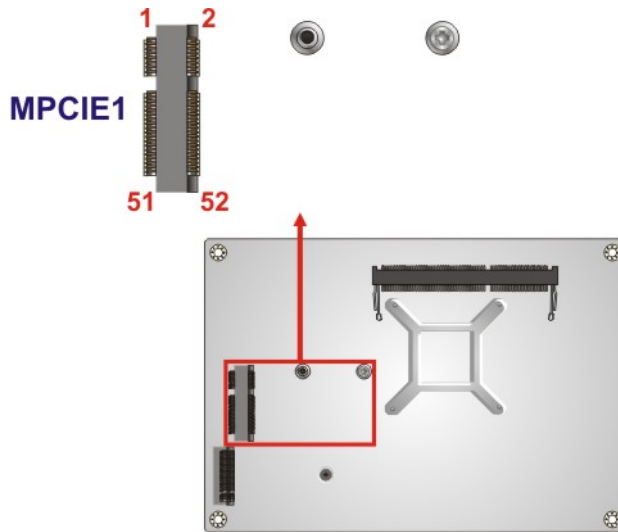

Figure 3-20: PCIe Mini Card Slot Location

Pin	Description	Pin	Description
1	PCIE_WAKE#	2	+3.3V
3	N/C	4	GND
5	N/C	6	1.5V
7	N/C	8	+VCC_SIM
9	GND	10	SIM_IO
11	MSATA_CLK#	12	SIM_CLK
13	MSATA_CLK	14	SIM_RST
15	GND	16	SIM_VPP
17	PCIRST#	18	GND
19	N/C	20	+3.3V
21	GND	22	PLTRST_N
23	PCIE_RXN	24	+3.3V
25	PCIE_RXP-	26	GND
27	GND	28	1.5V
29	GND	30	SMB_CLK
31	PCIE_TXN	32	SMB_DATA
33	PCIE_TXP	34	GND
35	GND	36	USB_DATA-
37	GND	38	USB_DATA+
39	+3.3V	40	GND
41	+3.3V	42	N/C
43	+3.3V	44	N/C
45	N/C	46	N/C
47	N/C	48	1.5V
49	N/C	50	GND
51	MSATA_DET	52	+3.3V

Table 3-19: PCIe Mini Card Slot Pinouts

NANO-AL EPIC SBC

3.2.20 Power Button (On-board)

- CN Label:** PWR_SW1
- CN Type:** Push button
- CN Location:** See **Figure 3-21**

Push the on-board power button to power on the NANO-AL.

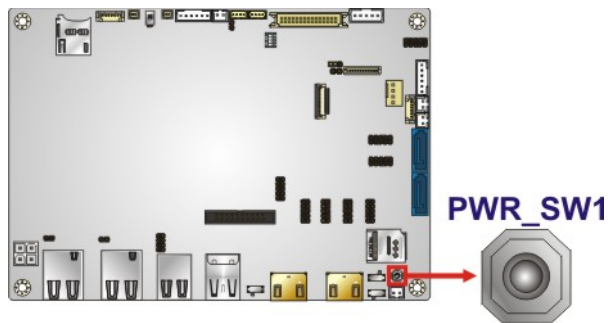

Figure 3-21: On-board Power Button Location

3.2.21 Power Button Connector

- CN Label:** PWR_BTN1
- CN Type:** 2-pin wafer, p=2 mm
- CN Location:** See **Figure 3-22**
- CN Pinouts:** See **Table 3-20**

The power button connector connects to the power button on the computer's front panel.

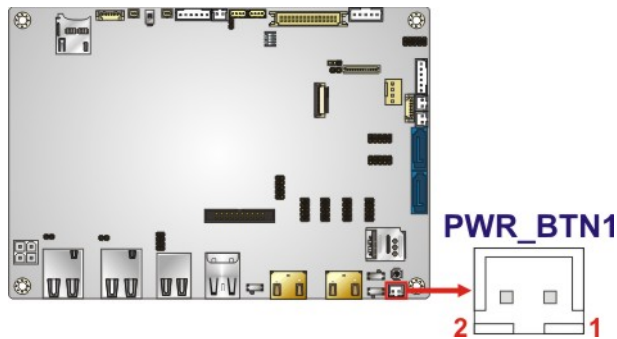

Figure 3-22: Power Button Connector Location

Pin	Description
1	PWR_BTN+
2	PWR_BTN-

Table 3-20: Power Button Connector Pinouts

3.2.22 Reset Button Connector

- CN Label:** RST_BTN1
- CN Type:** 2-pin wafer, p=2 mm
- CN Location:** See **Figure 3-23**
- CN Pinouts:** See **Table 3-21**

The reset button connector connects to the reset button on the computer's front panel.

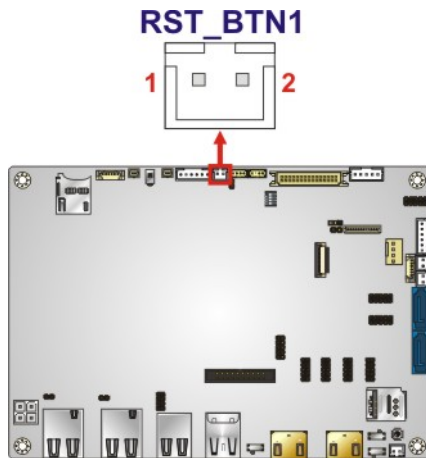

Figure 3-23: Reset Button Connector Location

Pin	Description
1	RESET+
2	RESET-

Table 3-21: Reset Button Connector Pinouts

NANO-AL EPIC SBC

3.2.23 SATA 6Gb/s Drive Connectors

- CN Label:** SATA1, SATA2
- CN Type:** 7-pin SATA connector
- CN Location:** See **Figure 3-24**
- CN Pinouts:** See **Table 3-22**

The SATA drive connectors can be connected to SATA drives and support up to 6Gb/s data transfer rate.

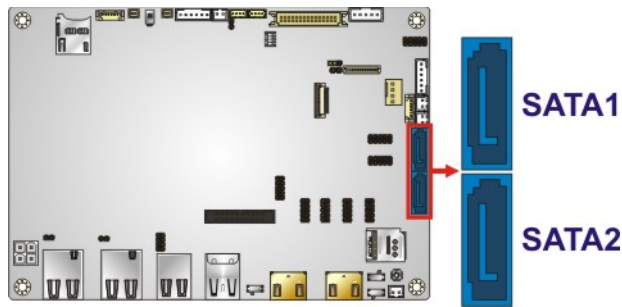

Figure 3-24: SATA 6Gb/s Drive Connector Locations

Pin	Description
1	GND
2	SATA_TX+
3	SATA_TX-
4	GND
5	SATA_RX-
6	SATA_RX+
7	GND

Table 3-22: SATA 6Gb/s Drive Connector Pinouts

3.2.24 SATA Power Connectors (5 V)

CN Label: SATAPWR1, SATAPWR2

CN Type: 2-pin wafer, p=2 mm

CN Location: See **Figure 3-25**

CN Pinouts: See **Table 3-23**

Use the SATA power connector to connect to SATA device power connections.

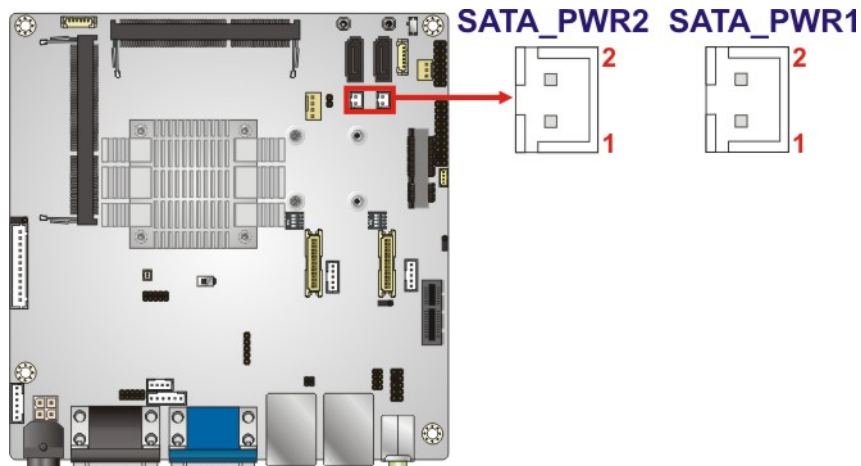

Figure 3-25: 5 V SATA Power Connector Locations

Pin	Description
1	+V5S
2	GND

Table 3-23: 5 V SATA Power Connector Pinouts

NANO-AL EPIC SBC

3.2.25 Serial Port Connector, RS-232

CN Label: COM1, COM2, COM3, COM4

CN Type: 10-pin header, p=2 mm

CN Location: See Figure 3-26

CN Pinouts: See Table 3-24

The 10-pin serial port connector provides one RS-232 serial communications channel.

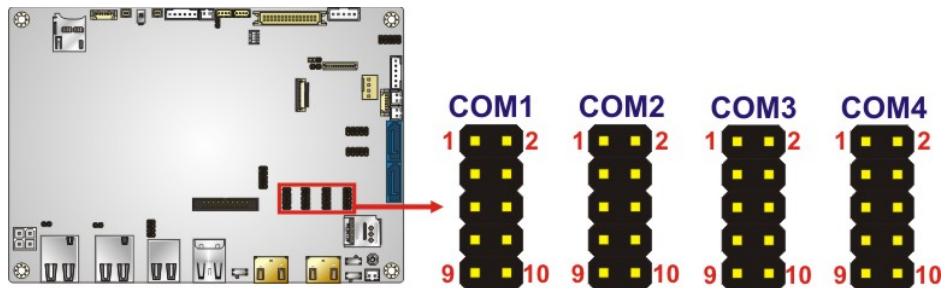

Figure 3-26: RS-232 Serial Port Connector Locations

Pin	Description	Pin	Description
1	DCD	2	DSR
3	RXD	4	RTS
5	TXD	6	CTS
7	DTR	8	RI
9	GND	10	GND

Table 3-24: RS-232 Serial Port Connector Pinouts

3.2.26 Serial Port Connector, RS-232/422/485

CN Label: COM5, COM6

CN Type: 10-pin header, p=2 mm

CN Location: See Figure 3-27

CN Pinouts: See Table 3-25

This connector provides RS-232, RS-422 or RS-485 communications.

Each of these connectors provides RS-232/422/485 connections.



NOTE:

The communication protocol of the serial ports is set through the BIOS menu in “Advanced → Super IO Configuration → Serial Port 5/6 Configuration”. Use the **Transfer Mode** BIOS option to configure the correspondent serial ports (refer to **Sections 5.3.3.1.5** and **5.3.3.1.6** for detailed information).

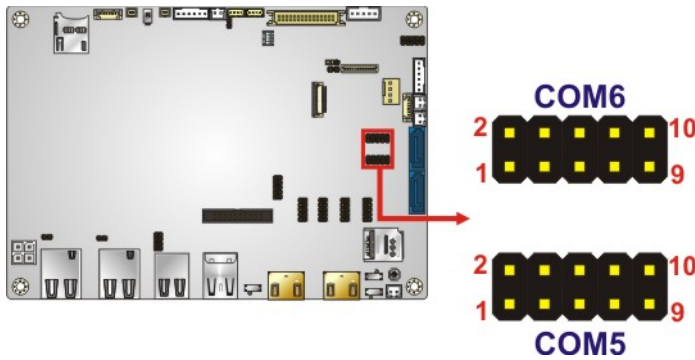

Figure 3-27: RS-232/422/485 Serial Port Connector Locations

Pin	Description	Pin	Description
1	DCD	2	DSR
3	RXD	4	RTS
5	TXD	6	CTS
7	DTR	8	RI
9	GND	10	GND

Table 3-25: RS-232/422/485 Serial Port Connector Pinouts

Use the optional RS-422/485 cable to connect to a serial device. The pinouts of the DB-9 connector are listed below.

NANO-AL EPIC SBC

RS-232 Pinouts	RS-422 Pinouts	RS-485 Pinouts
		

Table 3-26: DB-9 RS-232/422/485 Pinouts

3.2.27 SIM Card Slot (Optional)

- CN Label:** SIM1
- CN Type:** SIM card slot
- CN Location:** See **Figure 3-28**

The SIM card slot accepts a SIM card for 3G network communication.

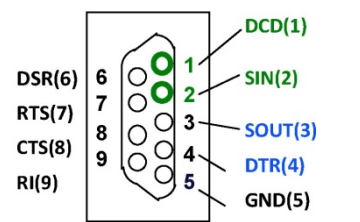
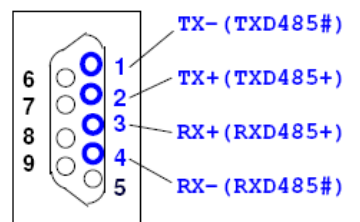
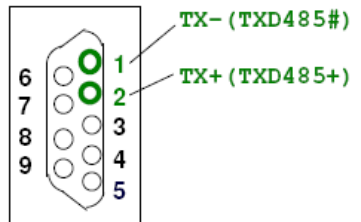

NOTE:

A WWAN module must be installed in the PCIe Mini slot (MPCIE1) to provide WWAN communication.

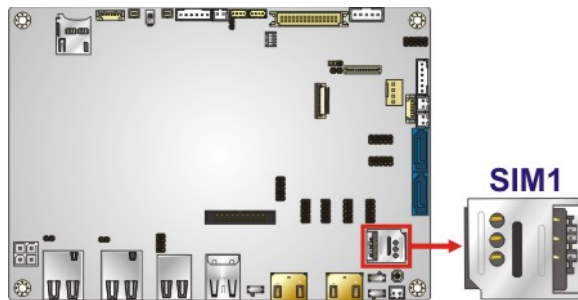

Figure 3-28: SIM Card Slot Location

3.2.28 SMBus Connector

- CN Label:** SMB1
- CN Type:** 4-pin wafer, p=1.25 mm
- CN Location:** See **Figure 3-29**
- CN Pinouts:** See **Table 3-27**

The SMBus (System Management Bus) connector provides low-speed system management communications.

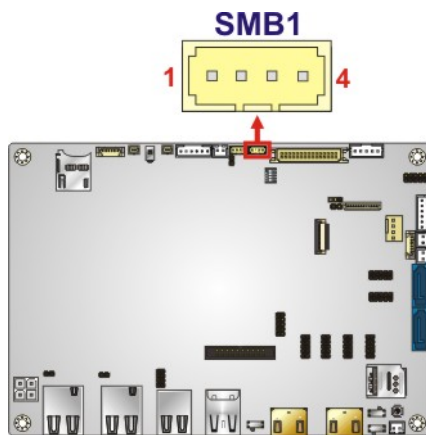

Figure 3-29: SMBus Connector Location

Pin	Description
1	GND
2	SMB_DATA
3	SMB_CLK
4	+V5S

Table 3-27: SMBus Connector Pinouts

3.2.29 SO-DIMM Connector

- CN Label:** DIMM1
- CN Type:** 204-pin DDR3L SO-DIMM connector
- CN Location:** See **Figure 3-30**

The SO-DIMM connector is for installing a DDR3L SO-DIMM on the system.

NANO-AL EPIC SBC

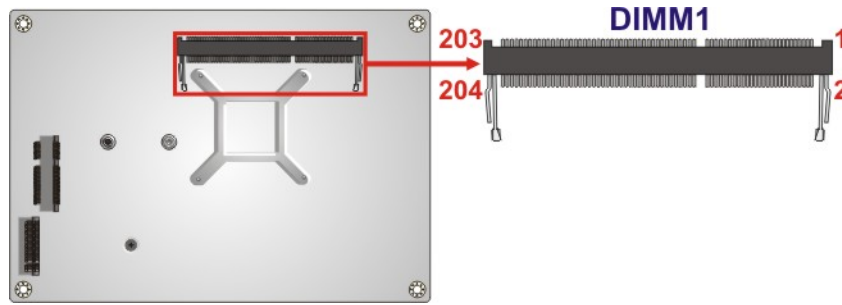

Figure 3-30: SO-DIMM Connector Location

3.2.30 SPI Flash Connector

- CN Label:** J_SPI1
- CN Type:** 6-pin wafer, $\rho=1.25$ mm
- CN Location:** See Figure 3-31
- CN Pinouts:** See Table 3-28

The SPI flash connector is used to flash the SPI ROM.

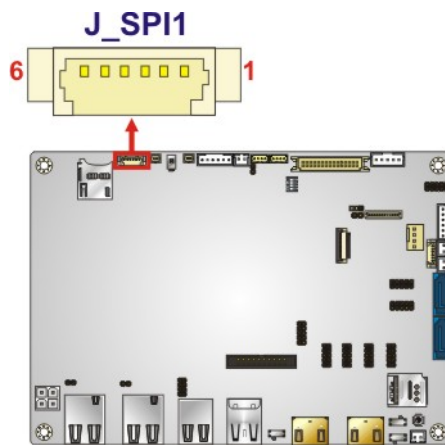

Figure 3-31: SPI Flash Connector Location

Pin	Description
1	+V3.3M_SPI_CON
2	SPI_CS
3	SPI_SO_SW

Pin	Description
4	SPI_CLK_SW
5	SPI_SI_SW
6	GND

Table 3-28: SPI Flash Connector Pinouts

3.2.31 SPI Flash Connector (EC)

- CN Label:** J_SPI2
- CN Type:** 6-pin wafer, p=1.25 mm
- CN Location:** See Figure 3-32
- CN Pinouts:** See Table 3-29

The SPI flash connector is used to flash the EC ROM.

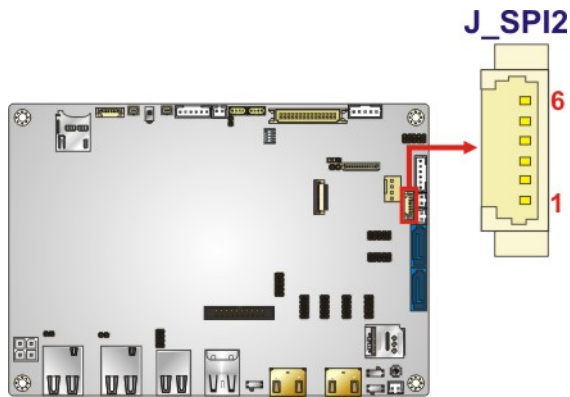

Figure 3-32: EC SPI Flash Connector Location

Pin	Description
1	+V3.3M_SPI_CON_EC
2	SPI_CS_EC
3	SPI_SO_SW_EC
4	SPI_CLK_SW_EC
5	SPI_SI_SW_EC
6	GND

Table 3-29: EC SPI Flash Connector Pinouts

NANO-AL EPIC SBC

3.2.32 USB 2.0 Connector

- CN Label:** USB2-2
- CN Type:** 8-pin header, p=2 mm
- CN Location:** See **Figure 3-33**
- CN Pinouts:** See **Table 3-30**

The USB header can connect to two USB 2.0 devices.

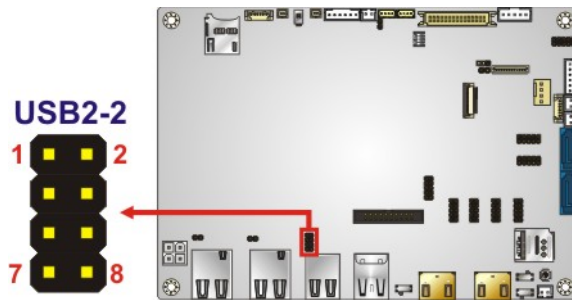

Figure 3-33: USB 2.0 Connector Location

Pin	Description	Pin	Description
1	VCC	2	GND
3	DATA-	4	DATA+
5	DATA+	6	DATA-
7	GND	8	VCC

Table 3-30: USB 2.0 Connector Pinouts

3.3 External Interface Connectors

The figure below shows the external peripheral interface connector (EPIC) panel. The EPIC panel consists of the following:

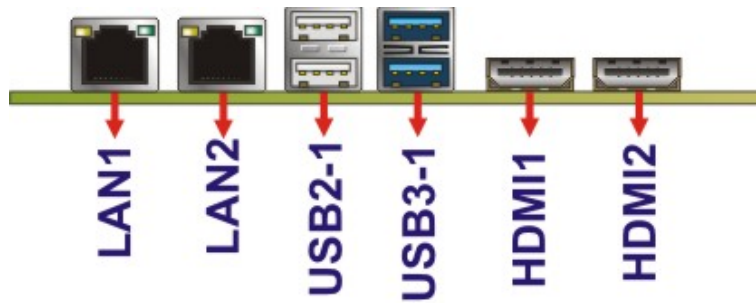

Figure 3-34: External Interface Connectors

3.3.1 HDMI Connectors

- CN Label:** HDMI1, HDMI2
- CN Type:** HDMI connector
- CN Location:** See **Figure 3-34**
- CN Pinouts:** See **Table 3-31**

The HDMI connectors can connect to HDMI devices.

Pin	Description	Pin	Description
1	HDMI_DATA2	2	GND
3	HDMI_DATA2#	4	HDMI_DATA1
5	GND	6	HDMI_DATA1#
7	HDMI_DATA0	8	GND
9	HDMI_DATA0#	10	HDMI_CLK
11	GND	12	HDMI_CLK#
13	N/C	14	N/C
15	HDMI_SCL	16	HDMI_SDA
17	GND	18	+5V
19	HDMI_HPD	20	HDMI_GND
21	HDMI_GND	22	HDMI_GND
23	HDMI_GND		

Table 3-31: HDMI Connector Pinouts

NANO-AL EPIC SBC

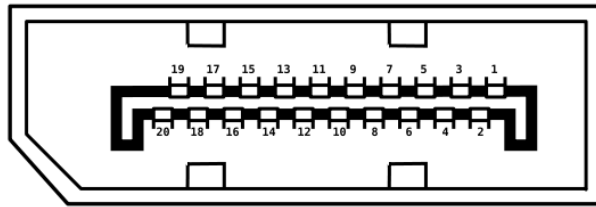

Figure 3-35: HDMI Connector Pinout Locations



NOTE:

The HDMI1 connector is co-lay with the iDP connector. When the iDP connector is enabled, the HDMI1 connector will be disabled. This is controlled by the HDMI/DP selection switch. Please refer to **Section 4.8.3** for detailed information.

3.3.2 LAN Connectors

- CN Label:** LAN1, LAN2
- CN Type:** RJ-45
- CN Location:** See **Figure 3-34**
- CN Pinouts:** See **Figure 3-36** and **Table 3-32**

The LAN connector connects to a local network.

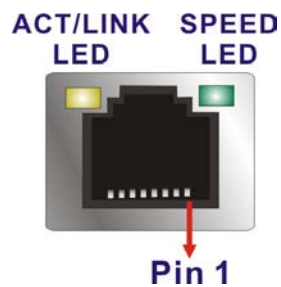

Figure 3-36: LAN Connector

Pin	Description	Pin	Description
1	TRD0+	5	TRD2+
2	TRD0-	6	TRD2-
3	TRD1+	7	TRD3+
4	TRD1-	8	TRD3-

Table 3-32: LAN Pinouts

3.3.3 USB 2.0 Connectors

- CN Label:** USB2-1
- CN Type:** USB Type-A port
- CN Location:** See **Figure 3-34**
- CN Pinouts:** See **Table 3-33**

The USB 2.0 connector can be connected to a USB 2.0/1.1 device.

Pin	Description
1	VCC
2	DATA-
3	DATA+
4	GND

Table 3-33: USB 2.0 Port Pinouts

3.3.4 USB 3.2 Gen 1 Connectors

- CN Label:** USB3-1
- CN Type:** USB Type-A port
- CN Location:** See **Figure 3-34**
- CN Pinouts:** See **Table 3-34**

The USB 3.2 Gen 1 (5Gb/s) connectors can be connected to a USB 2.0 or USB 3.2 Gen 1 device. The pinouts of USB 3.2 Gen 1 connectors are shown below.

NANO-AL EPIC SBC

Pin	Description	Pin	Description
1	+5V	2	USB2P0-
3	USB2P0+	4	GND
5	USB3P0_RXDN1	6	USB3P0_RXDP1
7	GND	8	USB3P0_TXDN1
9	USB3P0_TXDP1		

Table 3-34: USB 3.2 Gen 1 Port Pinouts

Chapter

4

Installation

NANO-AL EPIC SBC

4.1 Anti-static Precautions



WARNING:

Failure to take ESD precautions during installation may result in permanent damage to the product and severe injury to the user.

Electrostatic discharge (ESD) can cause serious damage to electronic components, including the NANO-AL. Dry climates are especially susceptible to ESD. It is therefore critical to strictly adhere to the following anti-static precautions whenever the NANO-AL, or any other electrical component, is handled.

- **Wear an anti-static wristband:** - Wearing a simple anti-static wristband can help to prevent ESD from damaging the board.
- **Self-grounding:**- Before handling the board touch any grounded conducting material. During the time the board is handled, frequently touch any conducting materials that are connected to the ground.
- **Use an anti-static pad:** When configuring the NANO-AL, place it on an anti-static pad. This reduces the possibility of ESD damaging the NANO-AL.
- **Only handle the edges of the PCB:-:** When handling the PCB, hold it by the edges.

4.2 Installation Considerations



NOTE:

The following installation notices and installation considerations should be read and understood before the NANO-AL is installed. All installation notices pertaining to the installation of NANO-AL should be strictly adhered to. Failing to adhere to these precautions may lead to severe damage of the NANO-AL and injury to the person installing the motherboard.

**WARNING:**

The installation instructions described in this manual should be carefully followed in order to prevent damage to the NANO-AL, NANO-AL components and injury to the user.

Before and during the installation please **DO** the following:

- **Read the user manual:**
 - The user manual provides a complete description of the installation instructions and configuration options.
- **Wear an electrostatic discharge cuff (ESD):**
 - Electronic components are easily damaged by ESD. Wearing an ESD cuff removes ESD from the body and helps prevent ESD damage.
- **Place on an anti-static pad:**
 - When installing or configuring the motherboard, place it on an anti-static pad. This helps to prevent potential ESD damage.
- **Turn all power off:**
 - Make sure the product is disconnected from all power supplies and that no electricity is being fed into the system.

Before and during the installation of the NANO-AL, **DO NOT:**

- Remove any of the stickers on the PCB board. These stickers are required for warranty validation.
- Use the product before verifying all the cables and power connectors are properly connected.
- Allow screws to come in contact with the PCB circuit, connector pins, or its components.

NANO-AL EPIC SBC

4.3 SO-DIMM Installation

To install a SO-DIMM, please follow the steps below and refer to **Figure 4-1**.



NOTE:

Use **DIMM1** slot when installing one SO-DIMM. For the SO-DIMM slot location, refer to **Figure 3-30**.

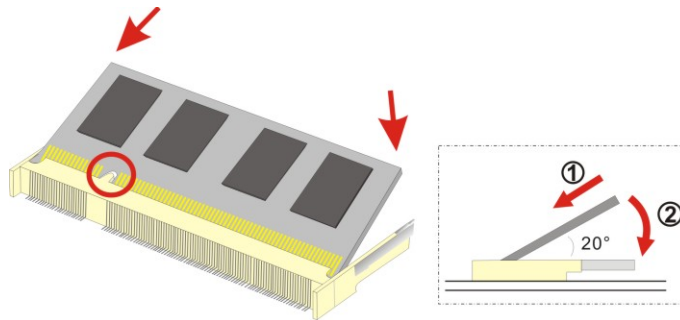

Figure 4-1: SO-DIMM Installation

- Step 1:** Locate the **SO-DIMM socket** on the solder side of the NANO-AL. Place the board on an anti-static mat.
- Step 2:** Align the **SO-DIMM with the socket**. Align the notch on the memory with the notch on the memory socket.
- Step 3:** Insert the **SO-DIMM**. Push the memory in at a 20° angle. (See **Figure 4-1**)
- Step 4:** Seat the **SO-DIMM**. Gently push downwards and the arms clip into place. (See **Figure 4-1**)

4.4 Full-size PCIe Mini Card Installation

The PCIe Mini card slot allows installation of either a full-size or half-size PCIe Mini card. To install a full-size PCIe Mini card, please follow the steps below.

- Step 1:** Locate the **PCIe Mini card slot**. See **Chapter 3**.

Step 2: Remove the retention screw. Remove the retention screw as shown in Figure 4-2.

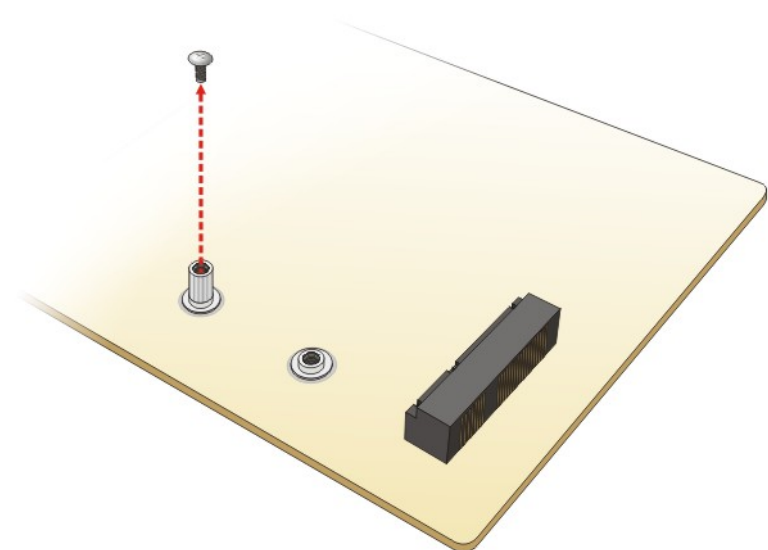

Figure 4-2: Removing the Retention Screw

Step 3: Insert into the socket at an angle. Line up the notch on the card with the notch on the slot. Slide the PCIe Mini card into the socket at an angle of about 20° (Figure 4-3).

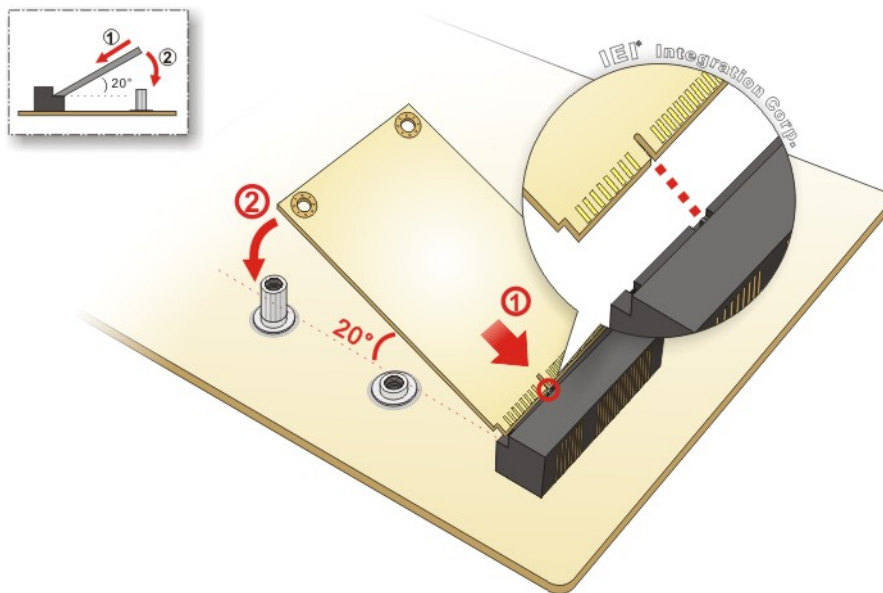

Figure 4-3: Inserting the Full-size PCIe Mini Card into the Slot at an Angle

NANO-AL EPIC SBC

Step 4: Secure the full-size PCIe Mini card. Secure the full-size PCIe Mini card with the retention screw previously removed (Figure 4-4).

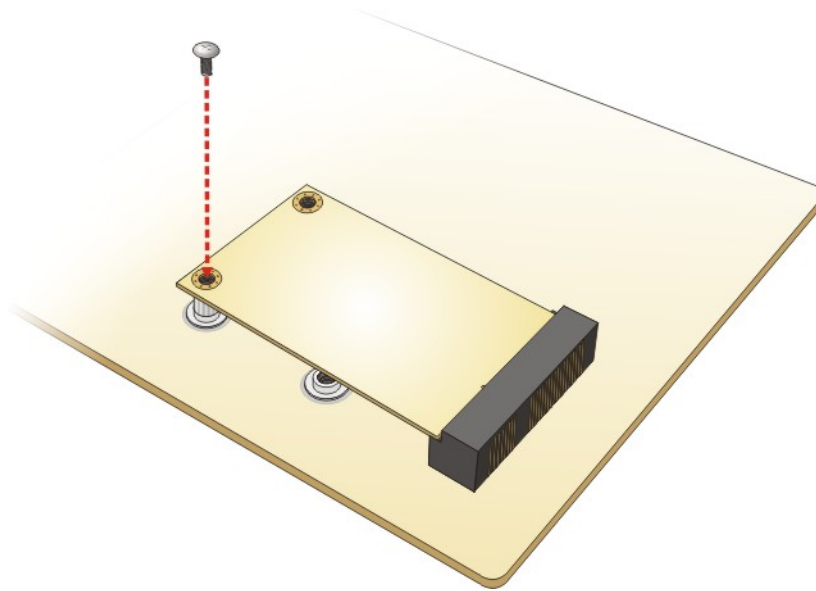

Figure 4-4: Securing the Full-size PCIe Mini Card

4.5 Half-size PCIe Mini Card Installation

The PCIe Mini card slot allows installation of either a full-size or half-size PCIe Mini card. To install a half-size PCIe Mini card, please follow the steps below.

Step 1: Locate the PCIe Mini card slot. See Chapter 3.

Step 2: Install the standoff to the screw hole for the half-size PCIe Mini card. Install the supplied standoff to the screw hole for the half-size PCIe Mini card (Figure 4-5).

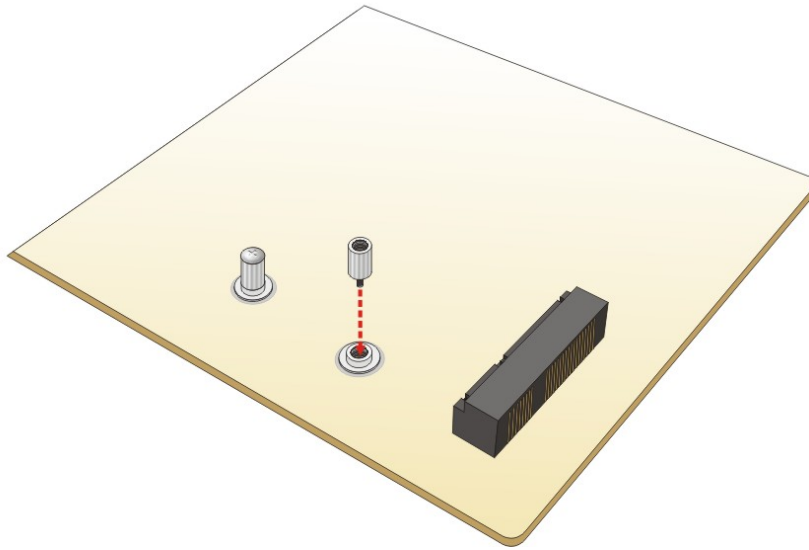

Figure 4-5: Installing the Standoff

Step 3: Insert into the socket at an angle. Line up the notch on the card with the notch on the slot. Slide the PCIe Mini card into the slot at an angle of about 20° (Figure 4-6).

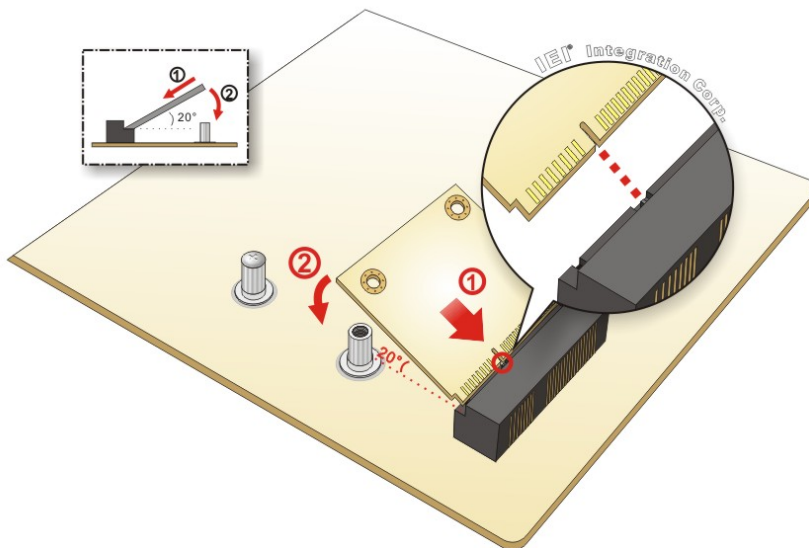

Figure 4-6: Inserting the Half-size PCIe Mini Card into the Slot at an Angle

Step 4: Secure the half-size PCIe Mini card. Secure the half-size PCIe Mini card with the supplied retention screw (Figure 4-7).

NANO-AL EPIC SBC

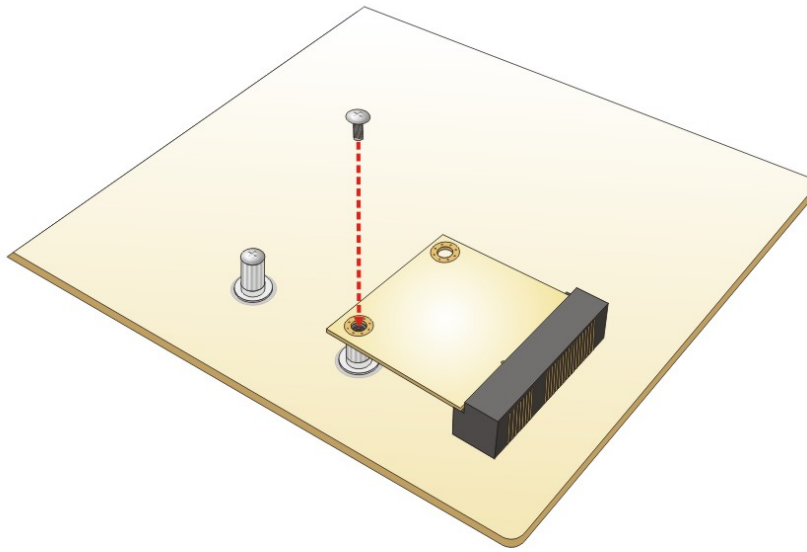

Figure 4-7: Securing the Half-size PCIe Mini Card

4.6 M.2 Module Installation

**NOTE:**

To use the SATA signal of the M.2 slot (**M2_1**), the user has to set the M.2 and SATA2 selection switch to B-C position. Please refer to **Section 4.8.6** for detail information.

To install an M.2 module, please follow the steps below.

Step 1: Locate the M.2 module slot. See **Chapter 3**.

Step 2: Remove the on-board retention screw as shown in **Figure 4-8**.

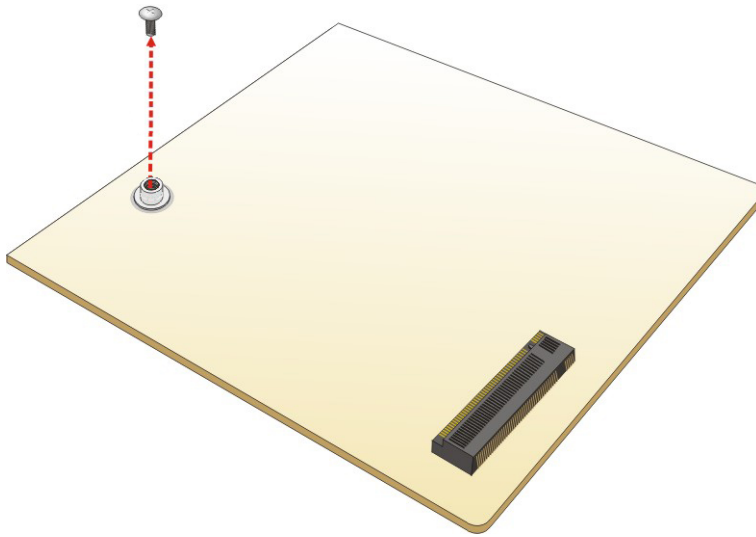

Figure 4-8: Removing the M.2 Module Retention Screw

Step 3: Line up the notch on the card with the notch on the slot. Slide the M.2 module into the socket at an angle of about 20° (**Figure 4-9**).

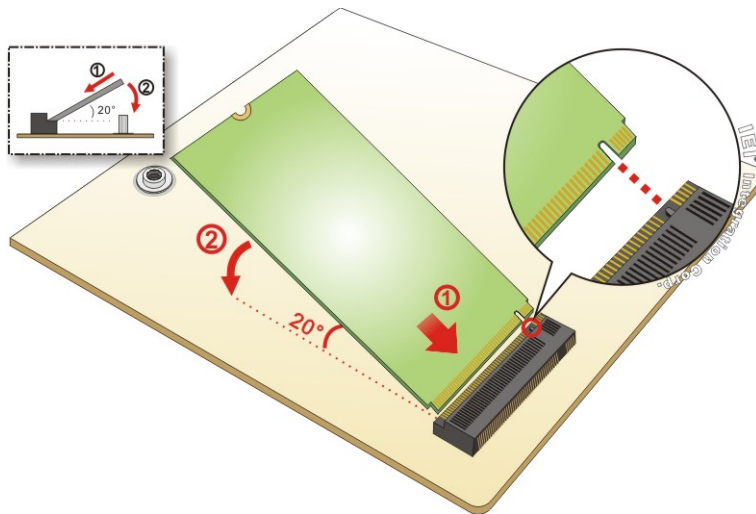

Figure 4-9: Inserting the M.2 Module into the Slot at an Angle

NANO-AL EPIC SBC

Step 4: Push the M.2 module down and secure it with the previously removed retention screw (**Figure 4-10**).

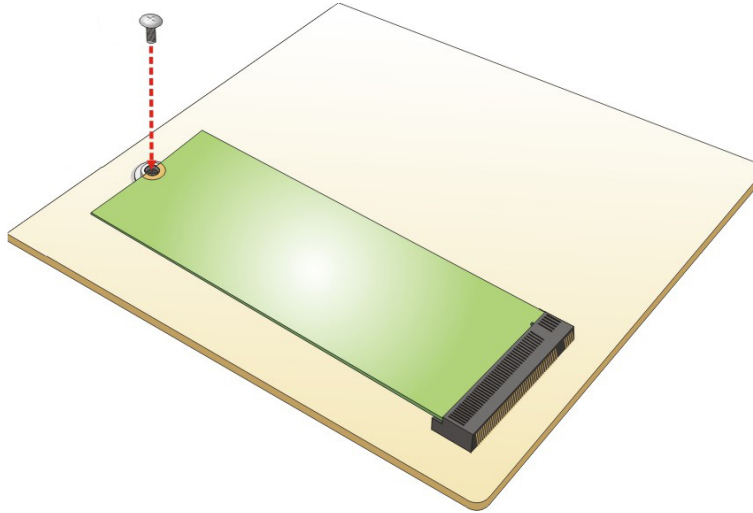

Figure 4-10: Securing the M.2 Module

4.7 SIM Card Installation

To install a SIM card, please follow the steps below.



NOTE:

A WWAN module must be installed in the PCIe Mini slot (MPCIE1) to provide WWAN communication.

Step 1: Locate the SIM card slot. See **Chapter 3**.

Step 2: Unlock the SIM card slot cover by sliding the cover in the direction as shown by the arrow in **Figure 4-11**.



Figure 4-11: Unlock SIM Card Slot Cover

Step 3: Open the slot cover and place a SIM card onto the slot. The cut mark on the corner should be facing away from the slot as shown in **Figure 4-12**.

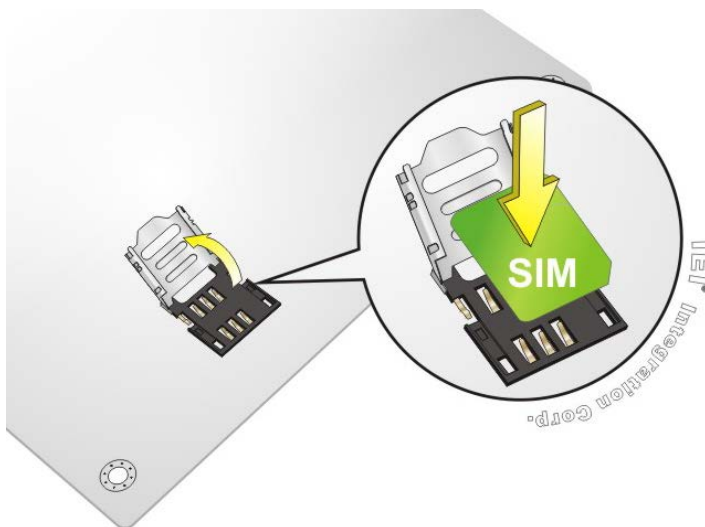

Figure 4-12: SIM Card Installation

Step 4: Close the slot cover and lock it by sliding it in the direction as shown by the arrow in **Figure 4-13**.

NANO-AL EPIC SBC



Figure 4-13: Lock SIM Card Slot Cover

4.8 System Configuration

The system configuration is controlled by buttons/jumpers/switches, and should be performed before installation.

4.8.1 AT/ATX Power Mode Selection

The AT and ATX power mode selection is made through the AT/ATX power mode switch which is shown in **Figure 4-14**.

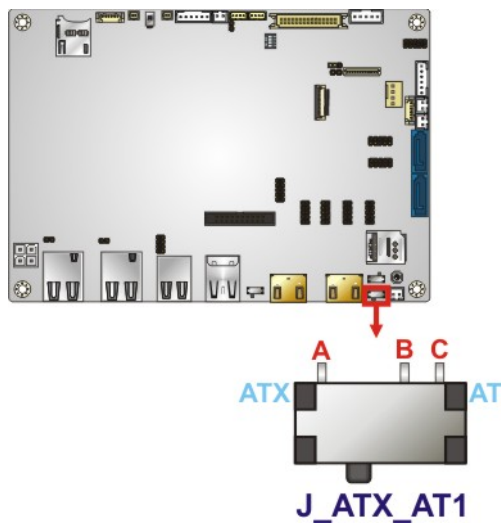

Figure 4-14: AT/ATX Power Mode Switch Location

Setting	Description
A-B	ATX power mode (default)
B-C	AT power mode

Table 4-1: AT/ATX Power Mode Switch Settings

4.8.2 Clear CMOS Button

To reset the BIOS, remove the on-board battery and press the clear CMOS button for three seconds or more. The clear CMOS button location is shown in **Figure 4-15**.

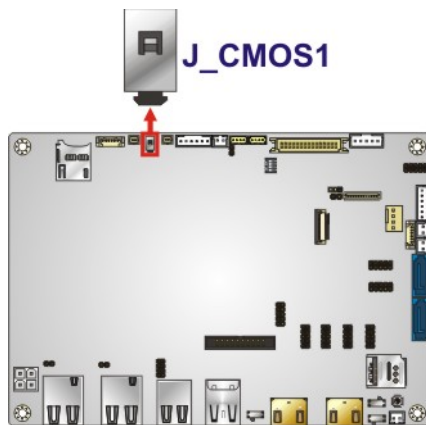

Figure 4-15: Clear CMOS Button Location

4.8.3 HDMI/DP Selection Switch

- CN Label:** J_HDMI_DP1
- CN Type:** Switch
- CN Location:** See **Figure 4-16**
- CN Settings:** See **Table 4-2**

Use the HDMI/DP selection switch to disable or enable the HDMI1 connector since the iDP connector (DP1) is co-lay with the HDMI1 connector. HDMI/DP selection switch settings are shown in **Table 4-2**.

NANO-AL EPIC SBC

Setting	Description
A-B	Enable HDMI1 and disable internal DisplayPort (DP1) (Default)
B-C	Enable internal DisplayPort (DP1) and disable HDMI1

Table 4-2: HDMI/DP Selection Switch Settings

The location of the HDMI/DP selection switch is shown in **Figure 4-16**.

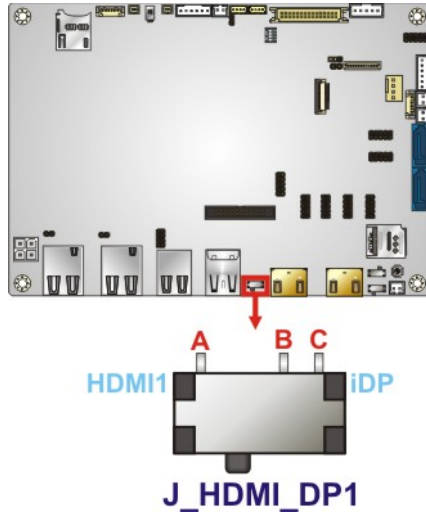

Figure 4-16: HDMI/DP Selection Switch Location

4.8.4 LVDS Panel Type Selection

Jumper Label:	SW1
Jumper Type:	DIP switch
Jumper Settings:	See Table 4-3
Jumper Location:	See Figure 4-17

Use the DIP switch to select the resolution of the LCD panel connected to the LVDS connector.

* ON=0, OFF=1

SW1 (4-3-2-1)	Description
0000	800x600 18-bit (default)
0001	1024x768 18-bit
0010	1024x768 24-bit
0011	1280x768 18-bit
0100	1280x800 18-bit
0101	1280x960 18-bit
0110	1280x1024 48-bit
0111	1366x768 18-bit
1000	1366x768 24-bit
1001	1440x960 48-bit
1010	1400x1050 48-bit
1011	1600x900 48-bit
1100	1680x1050 48-bit
1101	1600x1200 48-bit
1110	1920x1080 48-bit
1111	1920x1200 48-bit

Table 4-3: LVDS Panel Type Selection

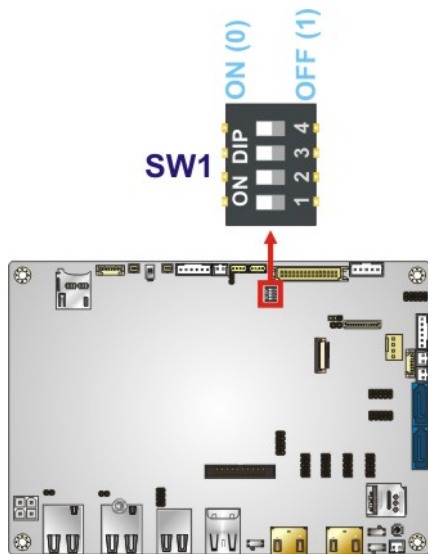

Figure 4-17: LVDS Panel Type Selection Switch Location

NANO-AL EPIC SBC

4.8.5 LVDS Voltage Selection



WARNING:

Permanent damage to the screen and NANO-AL may occur if the wrong voltage is selected with this jumper. Please refer to the user guide that came with the monitor to select the correct voltage.

- Jumper Label:** JP1
- Jumper Type:** 3-pin header
- Jumper Settings:** See Table 4-4
- Jumper Location:** See Figure 4-18

The LVDS voltage selection jumper allows setting the voltage provided to the monitor connected to the LVDS connector.

Setting	Description
Short 1-2	+3.3V LVDS (Default)
Short 2-3	+5V LVDS

Table 4-4: LVDS Voltage Selection Jumper Settings

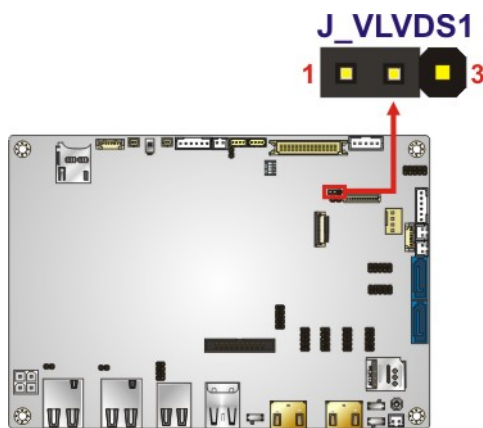

Figure 4-18: LVDS Voltage Selection Jumper Location

4.8.6 M.2 and SATA2 Selection Switch

To use the SATA signal of the M.2 slot (**M2_1**), the user has to set this switch to B-C position. The M.2 and SATA2 selection switch settings are shown in **Table 4-5**.

Setting	Description
A-B	SATA2 is enabled and M.2 SATA signal is disabled (Default)
B-C	M.2 SATA signal is enabled to be used and SATA2 is disabled.

Table 4-5: M.2 and SATA2 Selection Switch Settings

The location of the M.2 and SATA2 selection switch is shown in **Figure 4-19** below.

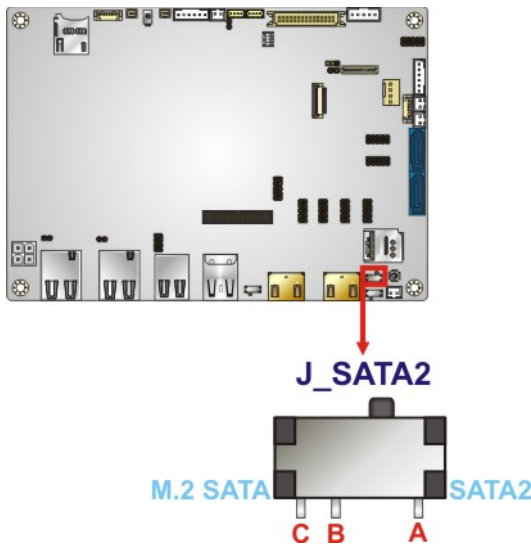

Figure 4-19: M.2 and SATA2 Selection Switch Location

NANO-AL EPIC SBC

4.8.7 Flash Descriptor Security Override Jumper

CN Label:	J_TXE1
CN Type:	2-pin header, p=2 mm
CN Location:	See Figure 4-20
CN Settings:	See Table 4-6

The Flash Descriptor Security Override jumper (ME_FLASH1) allows to enable or disable the ME firmware update. Refer to **Figure 4-19** and **Table 4-5** for the jumper location and settings.

Setting	Description
Open	Disabled (default)
Short	Enabled

Table 4-6: Flash Descriptor Security Override Jumper Settings

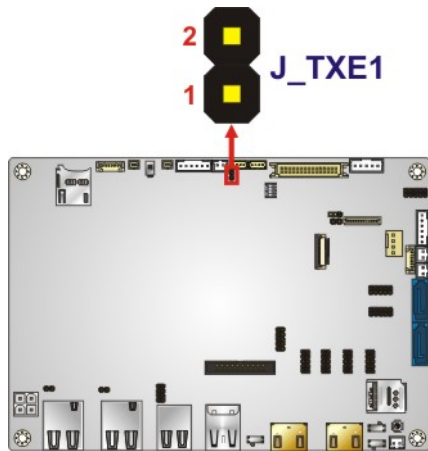

Figure 4-20: Flash Descriptor Security Override Jumper Location

To update the ME firmware, please follow the steps below.

- Step 1:** Before turning on the system power, short the Flash Descriptor Security Override jumper.
- Step 2:** Update the BIOS and ME firmware, and then turn off the system power.

Step 3: Remove the metal clip on the Flash Descriptor Security Override jumper.

Step 4: Restart the system. The system will reboot 2 ~ 3 times to complete the ME firmware update.

4.9 Chassis Installation

4.9.1 Airflow



WARNING:

Airflow is critical for keeping components within recommended operating temperatures. The chassis should have fans and vents as necessary to keep things cool.

The NANO-AL must be installed in a chassis with ventilation holes on the sides allowing airflow to travel through the heat sink surface. In a system with an individual power supply unit, the cooling fan of a power supply can also help generate airflow through the board surface.

4.9.2 Motherboard Installation

To install the NANO-AL motherboard into the chassis please refer to the reference material that came with the chassis.

NANO-AL EPIC SBC

4.10 Internal Peripheral Device Connections

This section outlines the installation of peripheral devices to the onboard connectors.

4.10.1 RS-232 Cable Connection

The single RS-232 cable consists of one serial port connector attached to a serial communications cable that is then attached to a D-sub 9 male connector. To install the single RS-232 cable, please follow the steps below.

Step 1: **Locate the connector.** The location of the RS-232 connector is shown in **Chapter 3**.

Step 2: **Insert the cable connector.** Align the cable connector with the onboard connector. Make sure pin 1 on the board and connector line up. Pin 1 on the cable connector is indicated with a white dot. See **Figure 4-21**.

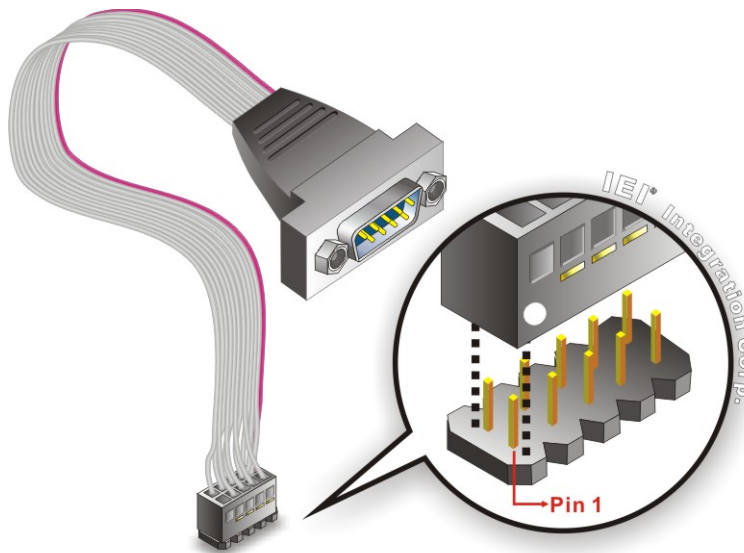

Figure 4-21: Single RS-232 Cable Installation

Step 3: **Secure the bracket.** The single RS-232 connector has two retention screws that must be secured to a chassis or bracket.

Step 4: **Connect the serial device.** Once the single RS-232 connector is connected to a chassis or bracket, a serial communications device can be connected to the system.

4.10.2 SATA Drive Connection

The NANO-AL is shipped with two SATA drive cables. To connect the SATA drive to the connector, please follow the steps below.

Step 1: **Locate the SATA connector and the SATA power connector.** The locations of the connectors are shown in **Chapter 3**.

Step 2: **Insert the cable connector.** Insert the cable connector into the on-board SATA drive connector and the SATA power connector. See **Figure 4-22**.

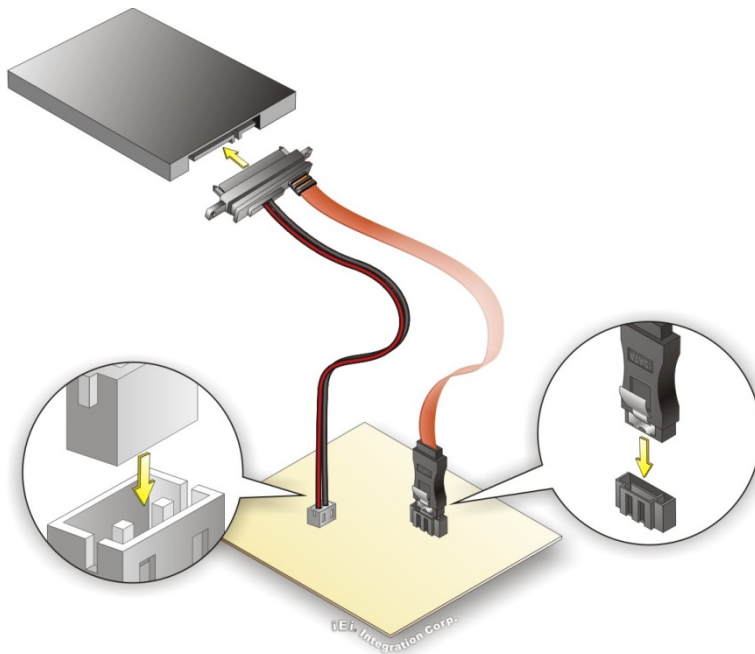

Figure 4-22: SATA Drive Cable Connection

Step 3: **Connect the cable to the SATA disk.** Connect the connector on the other end of the cable to the connector at the back of the SATA drive. See **Figure 4-22**.

Step 4: To remove the SATA cable from the SATA connector, press the clip on the connector at the end of the cable.

NANO-AL EPIC SBC

4.11 Software Installation

All the drivers for the NANO-AL are available on IEI Resource Download Center (<https://download.ieiworld.com>). Type NANO-AL and press Enter to find all the relevant software, utilities, and documentation.

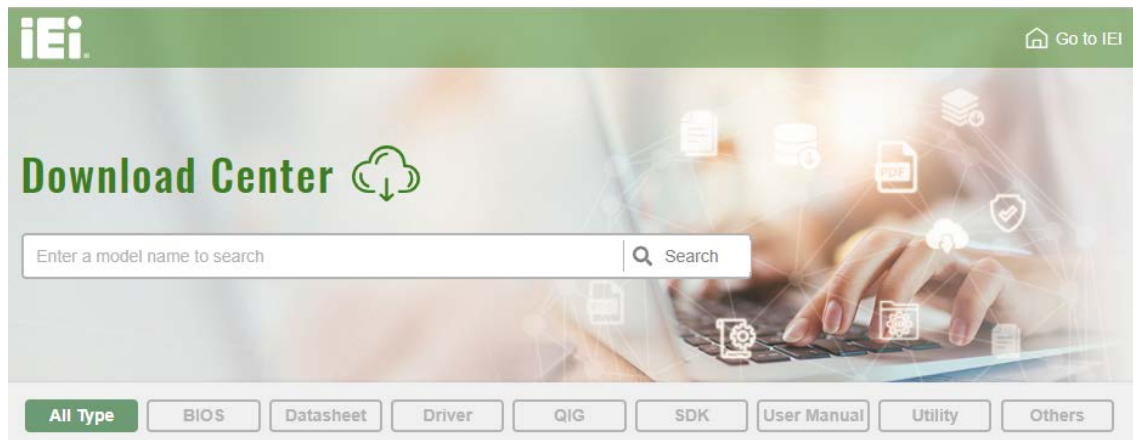
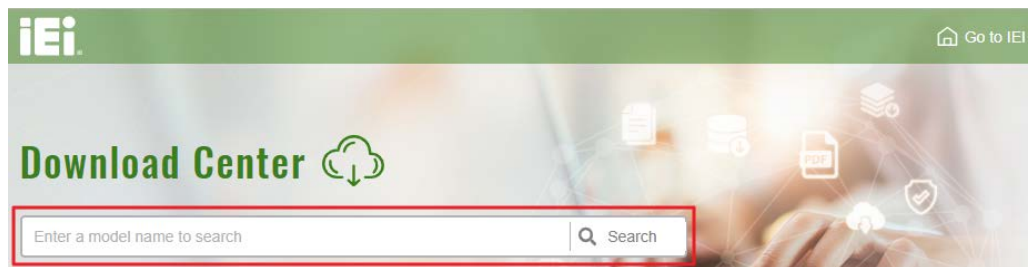

Figure 4-23: IEI Resource Download Center

4.11.1 Driver Download

To download drivers from IEI Resource Download Center, follow the steps below.

Step 1: Go to <https://download.ieiworld.com>. Type NANO-AL and press Enter.



Step 2: All product-related software, utilities, and documentation will be listed. You can choose **Driver** to filter the result.

All Type | BIOS | Datasheet | **Driver** | QIG | SDK | User Manual | Utility | Others

i Keyword: "NANO-AL", Searching Result : 11 Records.

NANO-AL Product Info ▶

Embedded Computer ▶ Single Board Computer ▶ Embedded Board

EPIC SBC supports 14nm Intel® Pentium®/Celeron®/Atom™ on-board SoC

Driver

File Name	Published	Version	File Checksum
NANO-AL_V1.0.iso (1.46 GB)	2018/06/13	1.00	174BC332056152F04AC03C3C5F30D98F

Step 3: Click the driver file name on the page and you will be prompted with the following window. You can download the entire ISO file (❶), or click the small arrow to find an individual driver and click the file name to download (❷).

NANO-AL_V1.0.iso [X]

❶ [Click here to download entire ISO file. \(1.46 GB\)](#)

* Download individual file *

- Docs
 - 1.Chipset
 - ❷ [10.1.1.38.zip \(2.6 MB\)](#)
 - 2.VGA
 - 3.LAN
 - 4.Audio
 - 5.SIO
 - 6.TXE
 - Thumbs.db (19.5 KB)



NOTE:

To install software from the downloaded ISO image file in Windows 8, 8.1 or 10, double-click the ISO file to mount it as a virtual drive to view its content. On Windows 7 system, an additional tool (such as Virtual CD-ROM Control Panel from Microsoft) is needed to mount the file.

Chapter

5

BIOS

5.1 Introduction

The BIOS is programmed onto the BIOS chip. The BIOS setup program allows changes to certain system settings. This chapter outlines the options that can be changed.



NOTE:

Some of the BIOS options may vary throughout the life cycle of the product and are subject to change without prior notice.

5.1.1 Starting Setup

The UEFI BIOS is activated when the computer is turned on. The setup program can be activated by pressing the **DEL** or **F2** key as soon as the system is turned on.

If the system enters the OS environment before the **DEL** or **F2** key is pressed, restart the computer and try again.

5.1.2 Using Setup

Use the arrow keys to highlight items, press **ENTER** to select, use the PageUp and PageDown keys to change entries, press **F1** for help and press **ESC** to quit. Navigation keys are shown in the following table.

Key	Function
Up arrow	Move to previous item
Down arrow	Move to next item
Left arrow	Move to the item on the left hand side
Right arrow	Move to the item on the right hand side
+	Increase the numeric value or make changes
-	Decrease the numeric value or make changes
Esc key	Main Menu – Quit and not save changes into CMOS Status Page Setup Menu and Option Page Setup Menu -- Exit current page and return to Main Menu

NANO-AL EPIC SBC

Key	Function
F1	General help, only for Status Page Setup Menu and Option Page Setup Menu
F2	Load previous values
F3	Load optimized defaults
F4	Save changes and Exit BIOS

Table 5-1: BIOS Navigation Keys

5.1.3 Getting Help

When **F1** is pressed a small help window describing the appropriate keys to use and the possible selections for the highlighted item appears. To exit the Help Window press **Esc** or the **F1** key again.

5.1.4 Unable to Reboot after Configuration Changes

If the computer cannot boot after changes to the system configuration are made, CMOS defaults. Use the clear CMOS button described in **Section 4.8.2**.

5.1.5 BIOS Menu Bar

The **menu bar** on top of the BIOS screen has the following main items:

- Main – Changes the basic system configuration.
- Advanced – Changes the advanced system settings.
- Chipset – Changes the chipset settings.
- Security – Sets User and Supervisor Passwords.
- Boot – Changes the system boot configuration.
- Save & Exit – Selects exit options and loads default settings.

The following sections completely describe the configuration options found in the menu items at the top of the BIOS screen and listed above.

5.2 Main

The **Main** BIOS menu (**BIOS Menu 1**) appears when the **BIOS Setup** program is entered.

The **Main** menu gives an overview of the basic system information.

```

Aptio Setup Utility - Copyright (C) 2017 American Megatrends, Inc.
Main  Advanced  Chipset  Security  Boot  Save & Exit

BIOS Information
BIOS Vendor          American Megatrends
Core Version         5.12
Compliance          UEFI 2.5; PI 1.4
Project Version      E428AR10b.BIN
Build Date and Time  02/16/2017 16:31:47

iWDD Vendor          iEi
iWDD Version         E4280222.bin

Platform firmware Information
BXT SOC              B1
MRC Version          0.56
PUNIT FW             20
PMC FW               03.26
TXE FW               3.0.12.1138
ISH FW               4.1.0.3364
GOP                  0.0.0036

Memory Information
Total Memory         4096 MB
Memory Speed         1600 MHz

Access Level          Administrator

System Date           [Tue 03/21/2017]
System Time           [15:10:27]

Version 2.18.1263. Copyright (C) 2017 American Megatrends, Inc.

Set the Date. Use Tab to
switch between Date
elements.

-----
-><: Select Screen
↑↓: Select Item
Enter: Select
+/-: Change Opt.
F1: General Help
F2: Previous Values
F3: Optimized Defaults
F4: Save & Exit
ESC: Exit
    
```

BIOS Menu 1: Main

The Main menu has two user configurable fields:

➔ **System Date [xx/xx/xx]**

Use the **System Date** option to set the system date. Manually enter the day, month and year.

➔ **System Time [xx:xx:xx]**

Use the **System Time** option to set the system time. Manually enter the hours, minutes and seconds.

NANO-AL EPIC SBC

5.3 Advanced

Use the **Advanced** menu (**BIOS Menu 2**) to configure the CPU and peripheral devices through the following sub-menus:



WARNING:

Setting the wrong values in the sections below may cause the system to malfunction. Make sure that the settings made are compatible with the hardware.

```

Aptio Setup Utility - Copyright (C) 2017 American Megatrends, Inc.
Main   Advanced  Chipset  Security  Boot    Save & Exit
-----
> Trusted Computing                Trusted Computing
> ACPI Settings                    Settings
> F81866 Super IO Configuration
> iWDD H/W Monitor
> USB Configuration
> CPU Configuration
> RTC Wake Settings
> Power Saving Configuration
> Serial Port Console Redirection
> iEi Feature

-----
-><: Select Screen
↑ ↓: Select Item
Enter: Select
+/-: Change Opt.
F1: General Help
F2: Previous Values
F3: Optimized Defaults
F4: Save & Exit
ESC: Exit

Version 2.18.1263. Copyright (C) 2017 American Megatrends, Inc.

```

BIOS Menu 2: Advanced

5.3.1 Trusted Computing

Use the **Trusted Computing** menu (**BIOS Menu 3**) to configure settings related to the Trusted Computing Group (TCG) Trusted Platform Module (TPM).

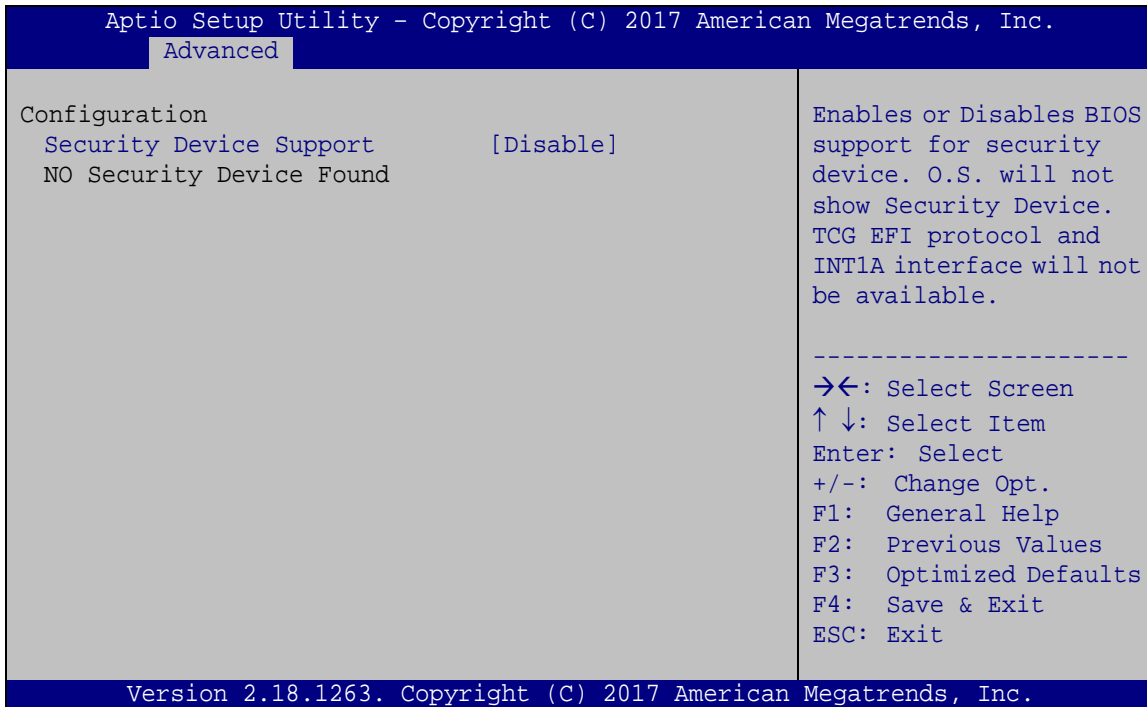

BIOS Menu 3: Trusted Computing

➔ Security Device Support [Disable]

Use the **Security Device Support** option to configure support for the TPM.

- ➔ **Disable** DEFAULT TPM support is disabled.
- ➔ **Enable** TPM support is enabled.

NANO-AL EPIC SBC

5.3.2 ACPI Settings

The **ACPI Settings** menu (**BIOS Menu 4**) configures the Advanced Configuration and Power Interface (ACPI) options.

```

Aptio Setup Utility - Copyright (C) 2017 American Megatrends, Inc.
-----
Advanced
-----
ACPI Settings
ACPI Sleep State          [S3(Suspend to RAM)]

Select the highest ACPI
sleep state the system
will enter when the
SUSPEND button is
pressed.

-----
-><: Select Screen
↑↓: Select Item
Enter: Select
+/-: Change Opt.
F1: General Help
F2: Previous Values
F3: Optimized Defaults
F4: Save & Exit
ESC: Exit

Version 2.18.1263. Copyright (C) 2017 American Megatrends, Inc.

```

BIOS Menu 4: ACPI Settings

➔ ACPI Sleep State [S3 (Suspend to RAM)]

Use the **ACPI Sleep State** option to specify the sleep state the system enters when it is not being used.

- ➔ **S3 (Suspend to DEFAULT RAM)** The caches are flushed and the CPU is powered off. Power to the RAM is maintained. The computer returns slower to a working state, but more power is saved.

5.3.3 F81866 Super IO Configuration

Use the **F81866 Super IO Configuration** menu (**BIOS Menu 5**) to set or change the configurations for the serial ports.

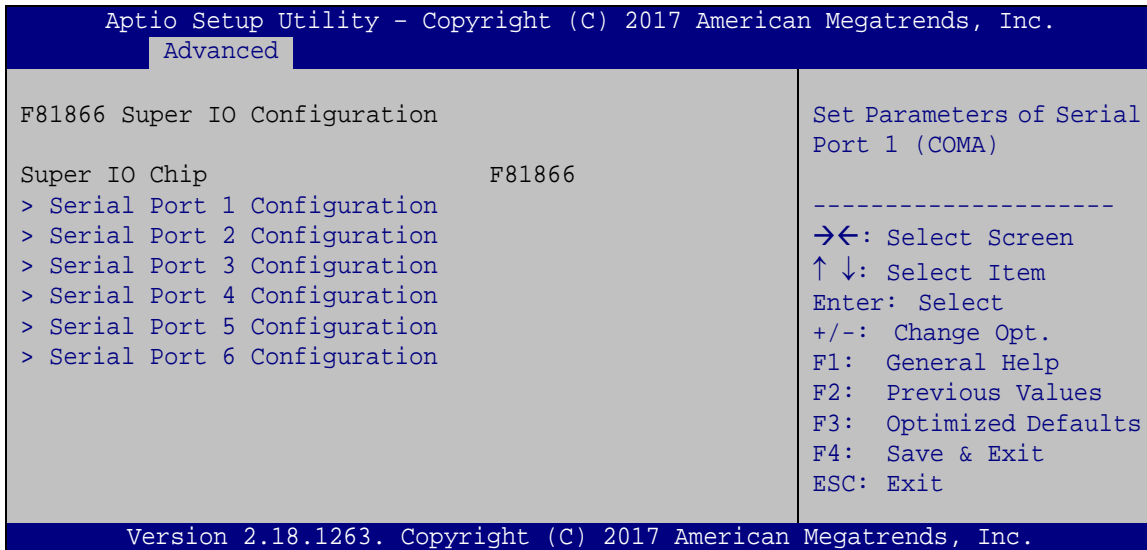

BIOS Menu 5: F81866 Super IO Configuration

5.3.3.1 Serial Port n Configuration

Use the **Serial Port n Configuration** menu (**BIOS Menu 6**) to configure the serial port n.

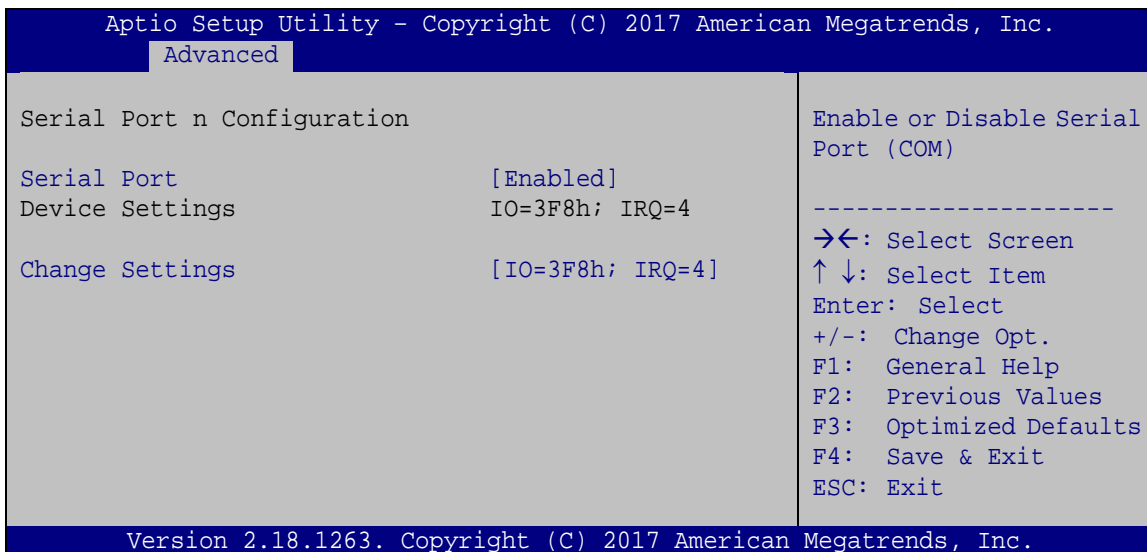

BIOS Menu 6: Serial Port n Configuration Menu

NANO-AL EPIC SBC

5.3.3.1.1 Serial Port 1 Configuration

→ Serial Port [Enabled]

Use the **Serial Port** option to enable or disable the serial port.

- **Disabled** Disable the serial port
- **Enabled** **DEFAULT** Enable the serial port

→ Change Settings [Auto]

Use the **Change Settings** option to change the serial port IO port address and interrupt address.

- **IO=3F8h;**
IRQ=4 Serial Port I/O port address is 3F8h and the interrupt address is IRQ4
- **IO=3F8h;**
IRQ=4 Serial Port I/O port address is 3F8h and the interrupt address is IRQ4
- **IO=2F8h;**
IRQ=4 Serial Port I/O port address is 2F8h and the interrupt address is IRQ4
- **IO=3E8h;**
IRQ=4 Serial Port I/O port address is 3E8h and the interrupt address is IRQ4
- **IO=2E8h;**
IRQ=4 Serial Port I/O port address is 2E8h and the interrupt address is IRQ4

5.3.3.1.2 Serial Port 2 Configuration

→ Serial Port [Enabled]

Use the **Serial Port** option to enable or disable the serial port.

- **Disabled** Disable the serial port
- **Enabled** **DEFAULT** Enable the serial port

➔ **Change Settings [Auto]**

Use the **Change Settings** option to change the serial port IO port address and interrupt address.

- ➔ **IO=2F8h;** Serial Port I/O port address is 2F8h and the interrupt
IRQ=7 address is IRQ7
- ➔ **IO=3F8h;** Serial Port I/O port address is 3F8h and the interrupt
IRQ=7 address is IRQ7
- ➔ **IO=2F8h;** Serial Port I/O port address is 2F8h and the interrupt
IRQ=7 address is IRQ7
- ➔ **IO=3E8h;** Serial Port I/O port address is 3E8h and the interrupt
IRQ=7 address is IRQ7
- ➔ **IO=2E8h;** Serial Port I/O port address is 2E8h and the interrupt
IRQ=7 address is IRQ7

5.3.3.1.3 Serial Port 3 Configuration

➔ **Serial Port [Enabled]**

Use the **Serial Port** option to enable or disable the serial port.

- ➔ **Disabled** Disable the serial port
- ➔ **Enabled DEFAULT** Enable the serial port

➔ **Change Settings [Auto]**

Use the **Change Settings** option to change the serial port IO port address and interrupt address.

- ➔ **IO=3E8h;** Serial Port I/O port address is 3E8h and the interrupt
IRQ=10 address is IRQ10
- ➔ **IO=3E8h;** Serial Port I/O port address is 3E8h and the interrupt
IRQ=10 address is IRQ10

NANO-AL EPIC SBC

- ➔ **IO=2E8h;**
IRQ=10 Serial Port I/O port address is 2E8h and the interrupt address is IRQ10
- ➔ **IO=3E0h;**
IRQ=10 Serial Port I/O port address is 3E0h and the interrupt address is IRQ10
- ➔ **IO=2E0h;**
IRQ=10 Serial Port I/O port address is 2E0h and the interrupt address is IRQ10

5.3.3.1.4 Serial Port 4 Configuration

➔ Serial Port [Enabled]

Use the **Serial Port** option to enable or disable the serial port.

- ➔ **Disabled** Disable the serial port
- ➔ **Enabled** **DEFAULT** Enable the serial port

➔ Change Settings [Auto]

Use the **Change Settings** option to change the serial port IO port address and interrupt address.

- ➔ **IO=2E8h;**
IRQ=10 Serial Port I/O port address is 2E8h and the interrupt address is IRQ10
- ➔ **IO=3E8h;**
IRQ=10 Serial Port I/O port address is 3E8h and the interrupt address is IRQ10
- ➔ **IO=2E8h;**
IRQ=10 Serial Port I/O port address is 2E8h and the interrupt address is IRQ10
- ➔ **IO=3E0h;**
IRQ=10 Serial Port I/O port address is 3E0h and the interrupt address is IRQ10
- ➔ **IO=2E0h;**
IRQ=10 Serial Port I/O port address is 2E0h and the interrupt address is IRQ10

5.3.3.1.5 Serial Port 5 Configuration

➔ Serial Port [Enabled]

Use the **Serial Port** option to enable or disable the serial port.

- ➔ **Disabled** Disable the serial port
- ➔ **Enabled** **DEFAULT** Enable the serial port

➔ Change Settings [Auto]

Use the **Change Settings** option to change the serial port IO port address and interrupt address.

- ➔ **IO=3E0h;**
IRQ=10 Serial Port I/O port address is 3E0h and the interrupt address is IRQ10
- ➔ **IO=3E8h;**
IRQ=10 Serial Port I/O port address is 3E8h and the interrupt address is IRQ10
- ➔ **IO=2E8h;**
IRQ=10 Serial Port I/O port address is 2E8h and the interrupt address is IRQ10
- ➔ **IO=3E0h;**
IRQ=10 Serial Port I/O port address is 3E0h and the interrupt address is IRQ10
- ➔ **IO=2E0h;**
IRQ=10 Serial Port I/O port address is 2E0h and the interrupt address is IRQ10

➔ Transfer Mode [RS232]

The serial port 5 allows setting the data transfer mode to RS-232, RS-422 or RS-485.

NANO-AL EPIC SBC

5.3.3.1.6 Serial Port 6 Configuration

➔ Serial Port [Enabled]

Use the **Serial Port** option to enable or disable the serial port.

- ➔ **Disabled** Disable the serial port
- ➔ **Enabled DEFAULT** Enable the serial port

➔ Change Settings [Auto]

Use the **Change Settings** option to change the serial port IO port address and interrupt address.

- ➔ **IO=2E0h;**
IRQ=10 Serial Port I/O port address is 2E0h and the interrupt address is IRQ10
- ➔ **IO=3E8h;**
IRQ=10 Serial Port I/O port address is 3E8h and the interrupt address is IRQ10
- ➔ **IO=2E8h;**
IRQ=10 Serial Port I/O port address is 2E8h and the interrupt address is IRQ10
- ➔ **IO=3E0h;**
IRQ=10 Serial Port I/O port address is 3E0h and the interrupt address is IRQ10
- ➔ **IO=2E0h;**
IRQ=10 Serial Port I/O port address is 2E0h and the interrupt address is IRQ10

➔ Transfer Mode [RS232]

The serial port 5 allows setting the data transfer mode to RS-232, RS-422 or RS-485.

5.3.4 iWDD H/W Monitor

The **iWDD H/W Monitor** menu (**BIOS Menu 7**) displays the system temperatures and voltages.

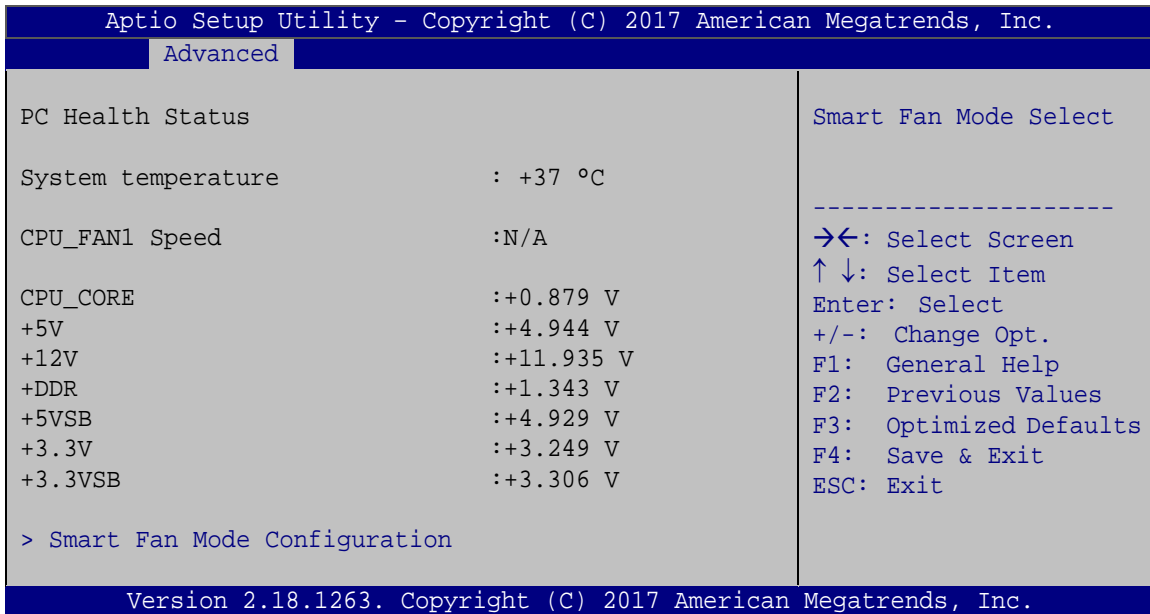

BIOS Menu 7: iWDD H/W Monitor

➔ PC Health Status

The following system parameters and values are shown. The system parameters that are monitored are:

- System temperature
- CPU fan speed
- Voltages:
 - CPU_CORE
 - +5V
 - +12V
 - +DDR
 - +5VSB
 - +3.3V
 - +3.3VSB

NANO-AL EPIC SBC

5.3.4.1 Smart Fan Mode Configuration

Use the **Smart Fan Mode Configuration** submenu (**BIOS Menu 8**) to configure smart fan temperature and speed settings.

```

Aptio Setup Utility - Copyright (C) 2017 American Megatrends, Inc.
-----
Advanced
-----
Smart Fan Mode Configuration
CPU_FAN1 Smart Fan Control      [Manual Mode]
Manual Mode                     70

Smart Fan Mode Select
-----
-><-: Select Screen
↑ ↓: Select Item
Enter>Select
+ - Change Opt.
F1  General Help
F2  Previous Values
F3  Optimized Defaults
F4  Save & Exit
ESC Exit

Version 2.18.1263. Copyright (C) 2017 American Megatrends, Inc.

```

BIOS Menu 8: Smart Fan Mode Configuration

→ CPU_FAN1 Smart Fan Control [Manual Mode]

Use the **CPU_FAN1 Smart Fan Control** option to configure the CPU Smart Fan.

→ **Manual Mode** **DEFAULT** The fan spins at the speed set in Manual Mode settings.

→ Manual Mode [70]

Use the +/- key or enter a decimal number between 1 and 100 to change the expected PWM fan type.

5.3.5 USB Configuration

Use the **USB Configuration** menu (**BIOS Menu 9**) to read USB configuration information and configure the USB settings.

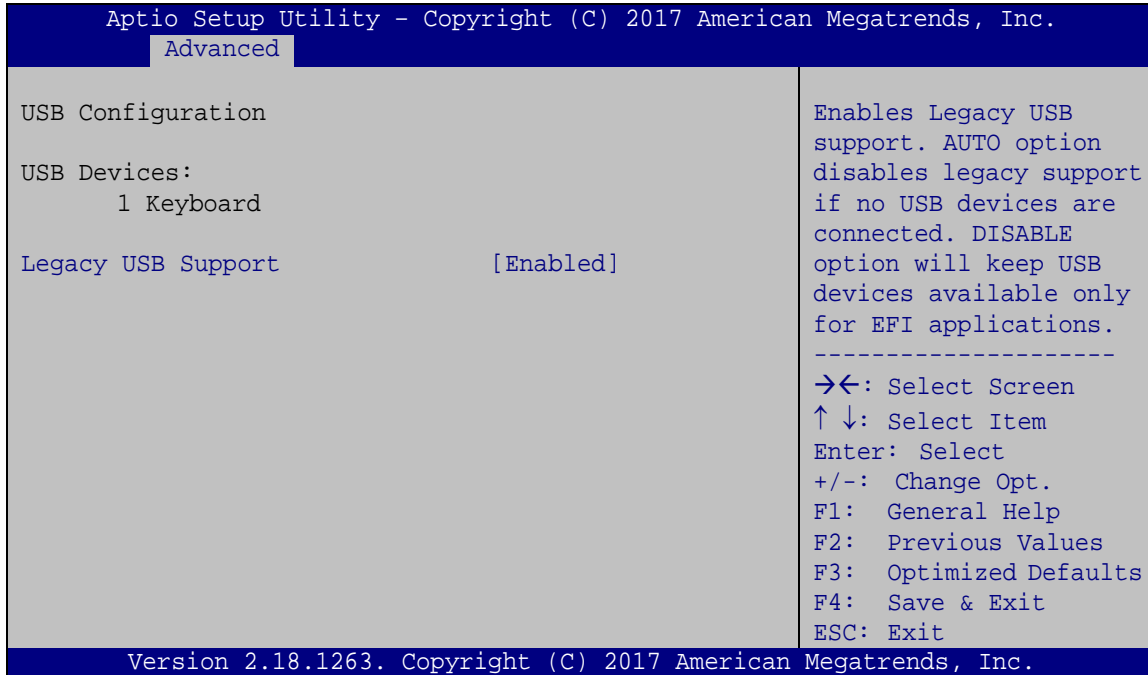

BIOS Menu 9: USB Configuration

➔ USB Devices

The **USB Devices** field lists the USB devices that are enabled on the system

➔ Legacy USB Support [Enabled]

Use the **Legacy USB Support** BIOS option to enable USB mouse and USB keyboard support. Normally if this option is not enabled, any attached USB mouse or USB keyboard does not become available until a USB compatible operating system is fully booted with all USB drivers loaded. When this option is enabled, any attached USB mouse or USB keyboard can control the system even when there is no USB driver loaded onto the system.

- ➔ **Enabled** **DEFAULT** Legacy USB support enabled
- ➔ **Disabled** Legacy USB support disabled
- ➔ **Auto** Legacy USB support disabled if no USB devices are connected

NANO-AL EPIC SBC

5.3.6 CPU Configuration

Use the **CPU Configuration** menu (**BIOS Menu 10**) to view detailed CPU specifications and configure its settings.

```

Aptio Setup Utility - Copyright (C) 2017 American Megatrends, Inc.
  Advanced
CPU Configuration
Intel(R) Atom(TM) Processor E3940 @ 1.60GHz
CPU Signature           506C9
Microcode Patch        20
Max CPU Speed          1600 MHz
Min CPU Speed          800 MHz
Processor Cores        4
Intel HT Technology     Not Supported
Intel VT-x Technology   Supported

L1 Data Cache          24 kB x 4
L1 Code Cache          32 kB x 4
L2 Cache               1024 kB x 2
L3 Cache               Not Present

EIST                   [Enabled]
C-States               [Disabled]
Intel Virtualization Technology [Disabled]
VT-d                   [Disabled]

Enable/Disable Intel SpeedStep

-----
-><: Select Screen
^ v: Select Item
Enter: Select
+/-: Change Opt.
F1: General Help
F2: Previous Values
F3: Optimized Defaults
F4: Save & Exit
ESC: Exit

Version 2.18.1263. Copyright (C) 2017 American Megatrends, Inc.
  
```

BIOS Menu 10: CPU Configuration

The CPU Configuration menu (**BIOS Menu 10**) lists the following CPU details:

- CPU Signature: Lists the CPU signature value.
- Microcode Patch: Lists the microcode patch being used.
- Max CPU Speed: Lists the maximum CPU processing speed.
- Min CPU Speed: Lists the minimum CPU processing speed.
- Processor Cores: Lists the number of the processor core
- Intel HT Technology: Indicates if Intel HT Technology is supported by the CPU.
- Intel VT-x Technology: Indicates if Intel VT-x Technology is supported by the CPU.
- L1 Data Cache: Lists the amount of data storage space on the L1 cache.

- L1 Code Cache: Lists the amount of code storage space on the L1 cache.
- L2 Cache: Lists the amount of storage space on the L2 cache.
- L3 Cache: Lists the amount of storage space on the L3 cache.

➔ **EIST [Enabled]**

Use the **EIST** option to enable or disable Enhanced Intel SpeedStep® Techonology (EIST).

- ➔ **Disabled** Disables Enhanced Intel SpeedStep® Techonology.
- ➔ **Enabled** **DEFAULT** Enables Enhanced Intel SpeedStep® Techonology.

➔ **C-States [Disabled]**

Use the **C-States** option to enable or disable the C-states.

- ➔ **Disabled** **DEFAULT** Disables the C-state
- ➔ **Enabled** Enables the C-state

➔ **Intel Virtualization Technology [Disabled]**

Use the **Intel Virtualization Technology** option to enable or disable virtualization on the system. When combined with third party software, Intel® Virtualization technology allows several OSs to run on the same system at the same time.

- ➔ **Disabled** **DEFAULT** Disables Intel Virtualization Technology.
- ➔ **Enabled** Enables Intel Virtualization Technology.

➔ **VT-d [Disabled]**

Use the **VT-d** option to enable or disable VT-d capability.

- ➔ **Disabled** **DEFAULT** Disables VT-d capability.
- ➔ **Enabled** Enables VT-d capability.

NANO-AL EPIC SBC

5.3.7 RTC Wake Settings

The **RTC Wake Settings** menu (**BIOS Menu 11**) enables the system to wake at the specified time.

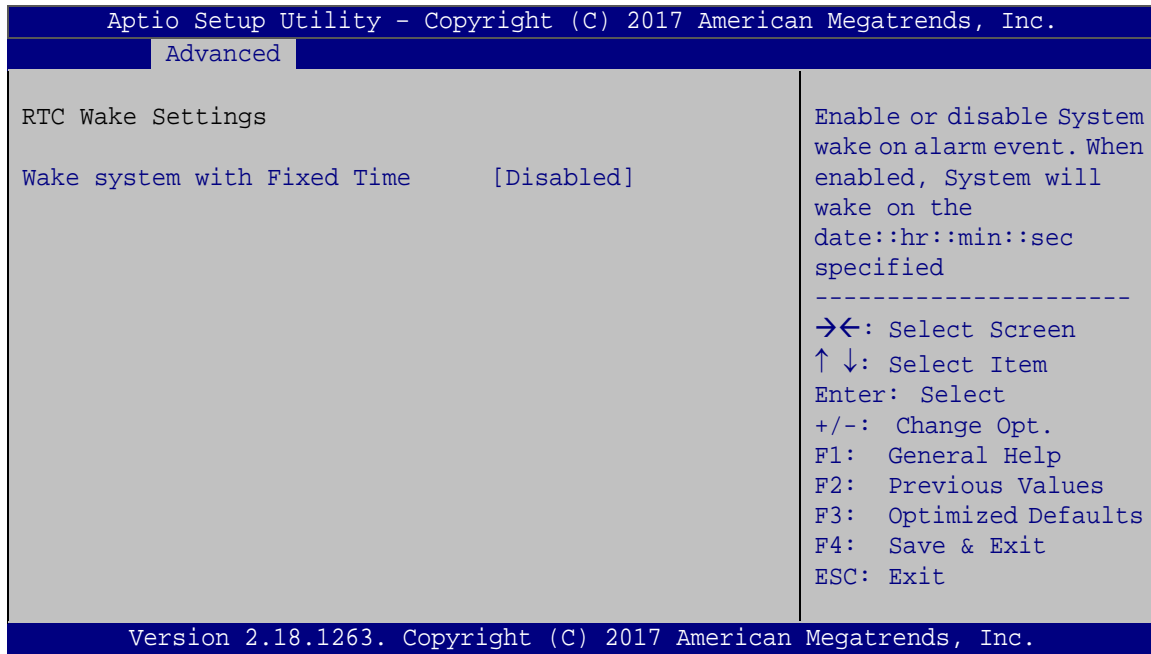

BIOS Menu 11: RTC Wake Settings

→ Wake system with Fixed Time [Disabled]

Use the **Wake system with Fixed Time** option to enable or disable the system wake on alarm event.

- **Disabled** **DEFAULT** The real time clock (RTC) cannot generate a wake event
- **Enabled** If selected, the **Wake up every day** option appears allowing you to enable to disable the system to wake every day at the specified time. Besides, the following options appear with values that can be selected:

Wake up every day

Wake up date

Wake up hour

Wake up minute

Wake up second

After setting the alarm, the computer turns itself on from a suspend state when the alarm goes off.

5.3.8 Power Saving Configuration

The **Power Saving Configuration** menu (**BIOS Menu 12**) allows the system to reduce power consumption when the system is off.

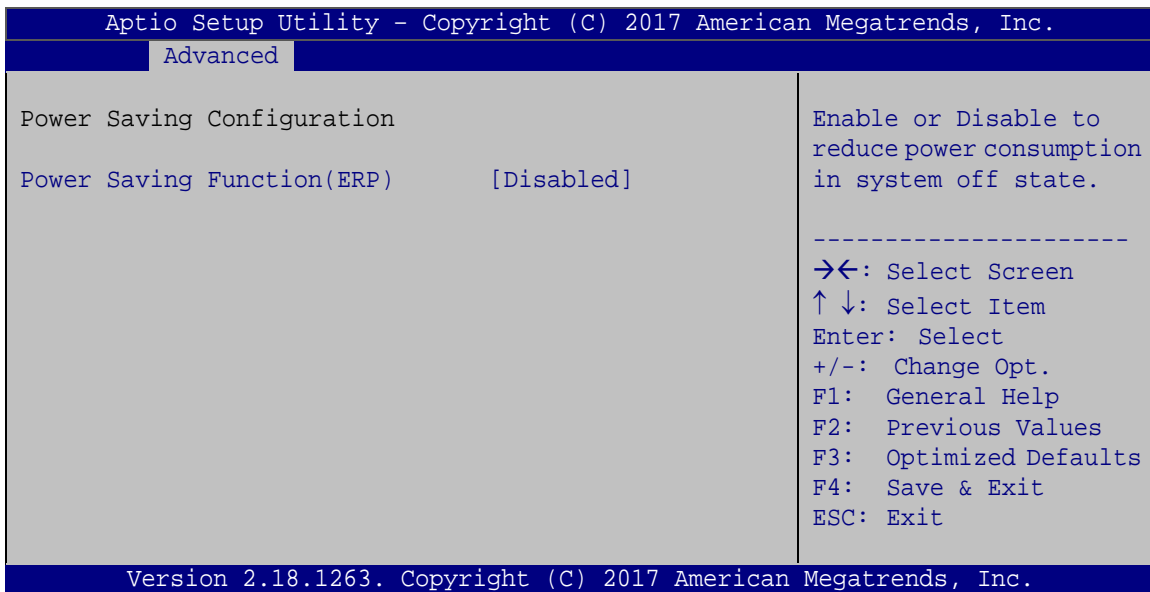

BIOS Menu 12: Power Saving Configuration

➔ Power Saving Function(ERP) [Disabled]

Use the **Power Saving Function(ERP)** option to enable or disable the power saving function.

- ➔ **Disabled** **DEFAULT** Power saving function is disabled.
- ➔ **Enabled** Power saving function is enabled. It will reduce power consumption when the system is off.

NANO-AL EPIC SBC

5.3.9 Serial Port Console Redirection

The **Serial Port Console Redirection** menu (**BIOS Menu 13**) allows the console redirection options to be configured. Console redirection allows users to maintain a system remotely by re-directing keyboard input and text output through the serial port.

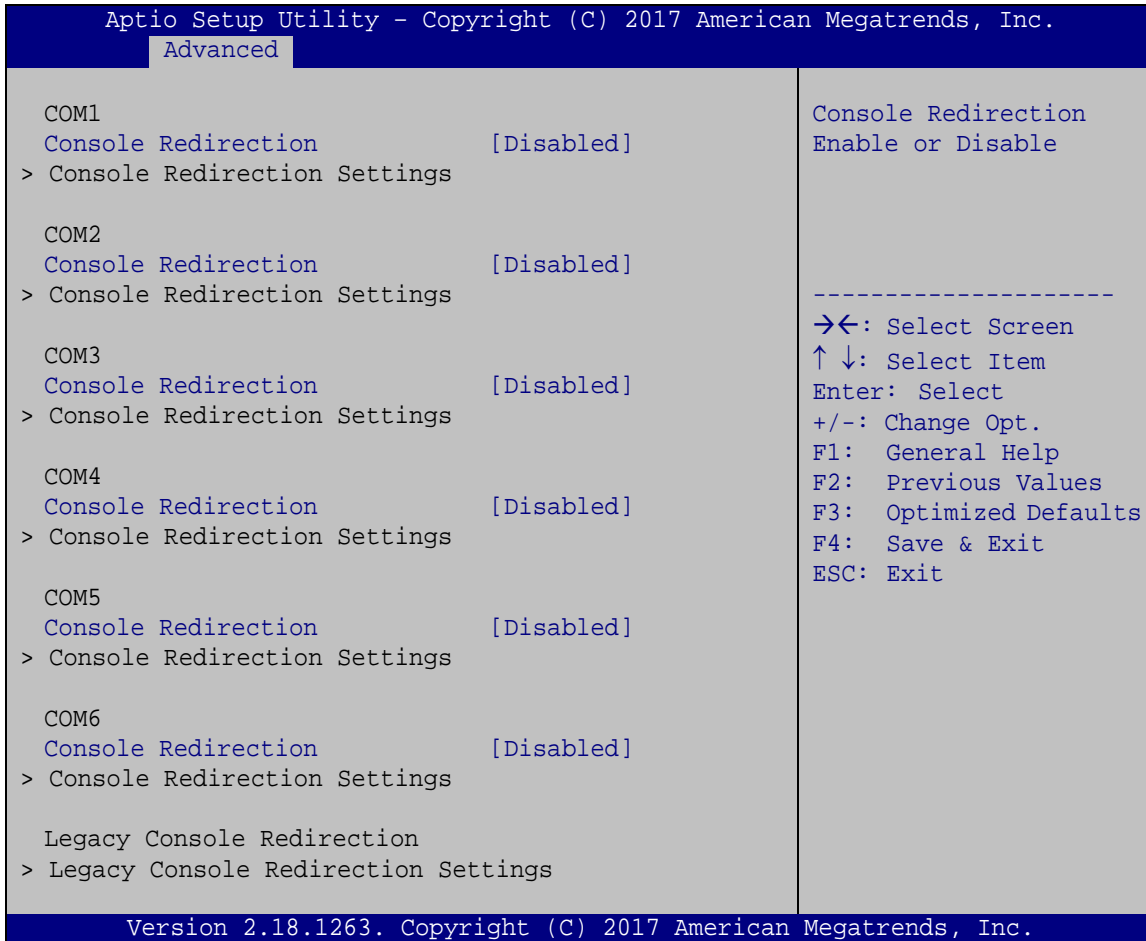

BIOS Menu 13: Serial Port Console Redirection

→ Console Redirection [Disabled]

Use **Console Redirection** option to enable or disable the console redirection function.

- **Disabled** **DEFAULT** Disabled the console redirection function
- **Enabled** Enabled the console redirection function

NANO-AL EPIC SBC

→ Parity [None]

Use the **Parity** option to specify the parity bit that can be sent with the data bits for detecting the transmission errors.

- **None** **DEFAULT** No parity bit is sent with the data bits.
- **Even** The parity bit is 0 if the number of ones in the data bits is even.
- **Odd** The parity bit is 0 if the number of ones in the data bits is odd.
- **Mark** The parity bit is always 1. This option does not provide error detection.
- **Space** The parity bit is always 0. This option does not provide error detection.

→ Stop Bits [1]

Use the **Stop Bits** option to specify the number of stop bits used to indicate the end of a serial data packet. Communication with slow devices may require more than 1 stop bit.

- **1** **DEFAULT** Sets the number of stop bits at 1.
- **2** Sets the number of stop bits at 2.

5.3.9.1 Legacy Console Redirection Settings

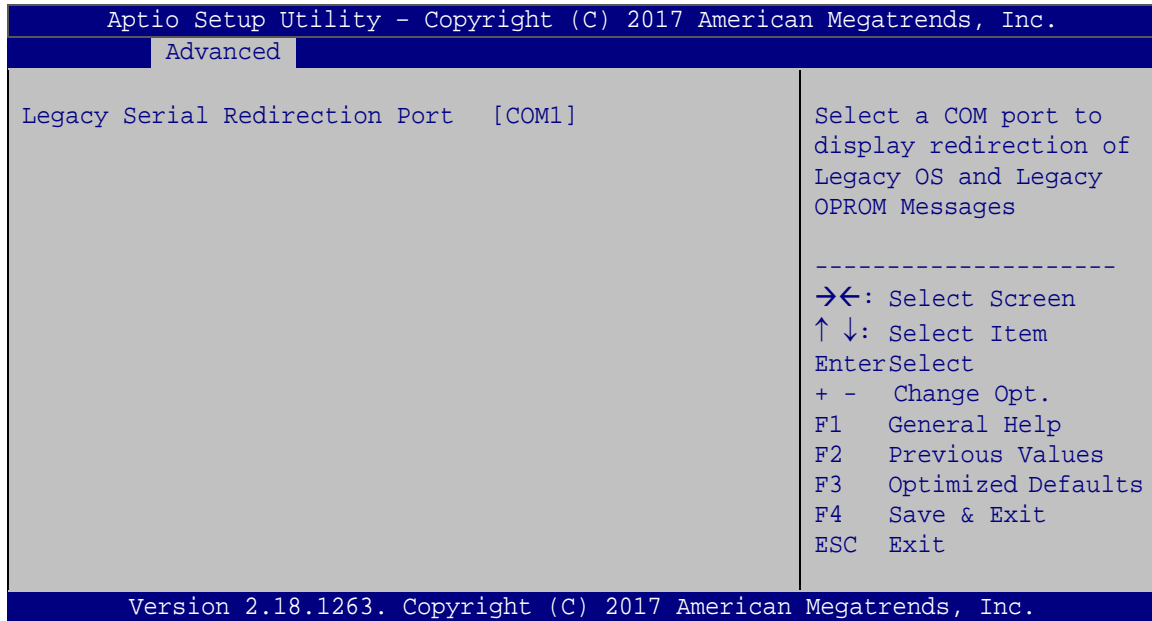

BIOS Menu 14: Legacy Console Redirection Settings

→ Legacy Serial Redirection Port [COM1]

Use the **Legacy Serial Redirection Port** option to select a COM port to display redirection of legacy OS and legacy OPRM messages. Configuration options are listed below.

- COM1 **Default**
- COM2
- COM3
- COM4
- COM5
- COM6

NANO-AL EPIC SBC

5.3.10 IEI Feature

Use the **IEI Feature** menu (**BIOS Menu 15**) to configure One Key Recovery function.

```

Aptio Setup Utility - Copyright (C) 2017 American Megatrends, Inc.
-----
Advanced
-----
iEi Feature
Auto Recovery Function          [Disabled]
                                Auto Recovery Function
                                Reboot and recover
                                system automatically
                                within 10 min, when OS
                                crashes. Please install
                                Auto Recovery API
                                service before enabling
                                this function
                                -----
                                ←→: Select Screen
                                ↑↓: Select Item
                                EnterSelect
                                F1  General Help
                                F2  Previous Values
                                F3  Optimized Defaults
                                F4  Save
                                ESC Exit

Version 2.18.1263. Copyright (C) 2017 American Megatrends, Inc.

```

BIOS Menu 15: IEI Feature

➔ Auto Recovery Function [Disabled]

Use the **Auto Recovery Function** BIOS option to enable or disable the auto recovery function of the IEI One Key Recovery.

- ➔ **Disabled** **DEFAULT** Auto recovery function disabled
- ➔ **Enabled** Auto recovery function enabled

5.4 Chipset

Use the **Chipset** menu (**BIOS Menu 16**) to access the chipset configuration menus.

```

Aptio Setup Utility - Copyright (C) 2017 American Megatrends, Inc.
Main   Advanced  Chipset   Security  Boot   Save & Exit

> North Bridge
> South Bridge

North Bridge Parameters

-----
-><: Select Screen
↑↓: Select Item
Enter: Select
+/-: Change Opt.
F1: General Help
F2: Previous Values
F3: Optimized Defaults
F4: Save & Exit
ESC: Exit

Version 2.18.1263. Copyright (C) 2017 American Megatrends, Inc.
    
```

BIOS Menu 16: Chipset

5.4.1 North Bridge

Use the **North Bridge** menu (**BIOS Menu 17**) to configure the north bridge parameters.

```

Aptio Setup Utility - Copyright (C) 2017 American Megatrends, Inc.
Chipset

> Intel IGD Configuration
> LCD Control

Memory Information

Total Memory          4096 MB (LPDDR3)
Dimml                 4096 MB (LPDDR3)

Configure Intel IGD
Settings.

-----
-><: Select Screen
↑↓: Select Item
EnterSelect
+ - Change Opt.
F1 General Help
F2 Previous Values
F3 Optimized Defaults
F4 Save & Exit
ESC Exit

Version 2.18.1263. Copyright (C) 2017 American Megatrends, Inc.
    
```

BIOS Menu 17: North Bridge

NANO-AL EPIC SBC

5.4.1.1 Intel IGD Configuration

Use the **Intel IGD Configuration** submenu (**BIOS Menu 18**) to configure the graphics settings.

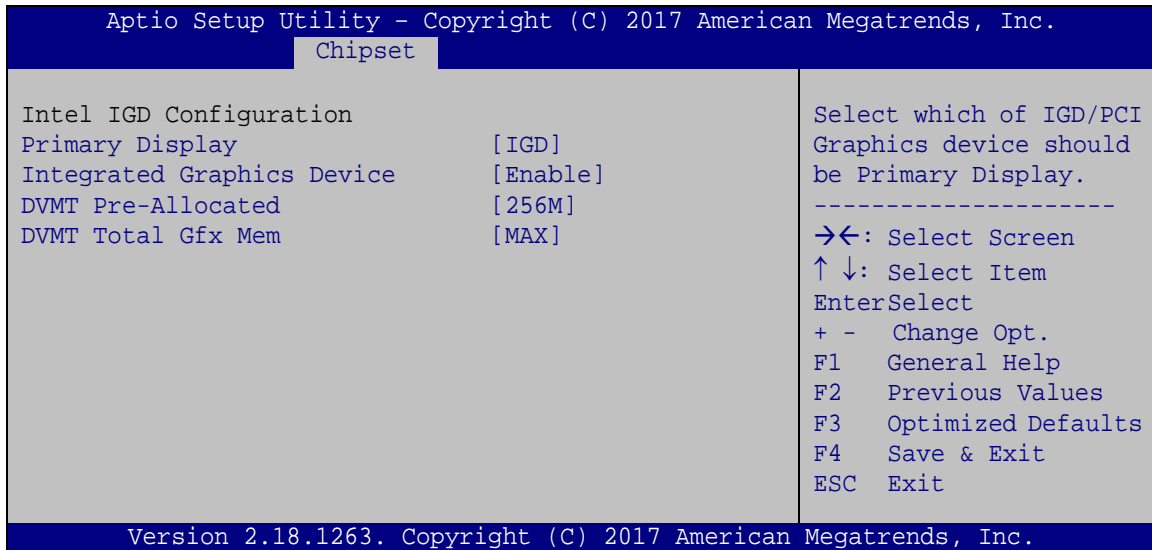

BIOS Menu 18: Intel IGD Configuration

➔ Primary Display [IGD]

Use the **Primary Display** option to select the display device used by the system when it boots. Configuration options are listed below.

- IGD **DEFAULT**
- PCIe

➔ Integrated Graphics Device [Enable]

Use the **Integrated Graphics Device** option to enable or disable the Integrated Graphics Device (IGD).

- ➔ **Disable** Always disables IGD.
- ➔ **Enable** **DEFAULT** Enables the Integrated Graphics Device (IGD) when selected as the primary video adaptor.

➔ **DVMT Pre-Allocated [256M]**

Use the **DVMT Pre-Allocated** option to specify the amount of system memory that can be used by the internal graphics device.

- | | | | |
|---|-------------|----------------|---|
| ➔ | 64M | | 64 MB of memory used by internal graphics device |
| ➔ | 128M | | 128 MB of memory used by internal graphics device |
| ➔ | 256M | DEFAULT | 256 MB of memory used by internal graphics device |
| ➔ | 512M | | 512 MB of memory used by internal graphics device |

➔ **DVMT Total Gfx Mem [MAX]**

Use the **DVMT Total Gfx Mem** option to specify the maximum amount of memory that can be allocated as graphics memory. Configuration options are listed below.

- 128MB
- 256MB
- **MAX** **Default**

NANO-AL EPIC SBC

5.4.1.2 LCD Control

Use the **LCD Control** submenu (**BIOS Menu 18**) to select a display device which will be activated during POST.

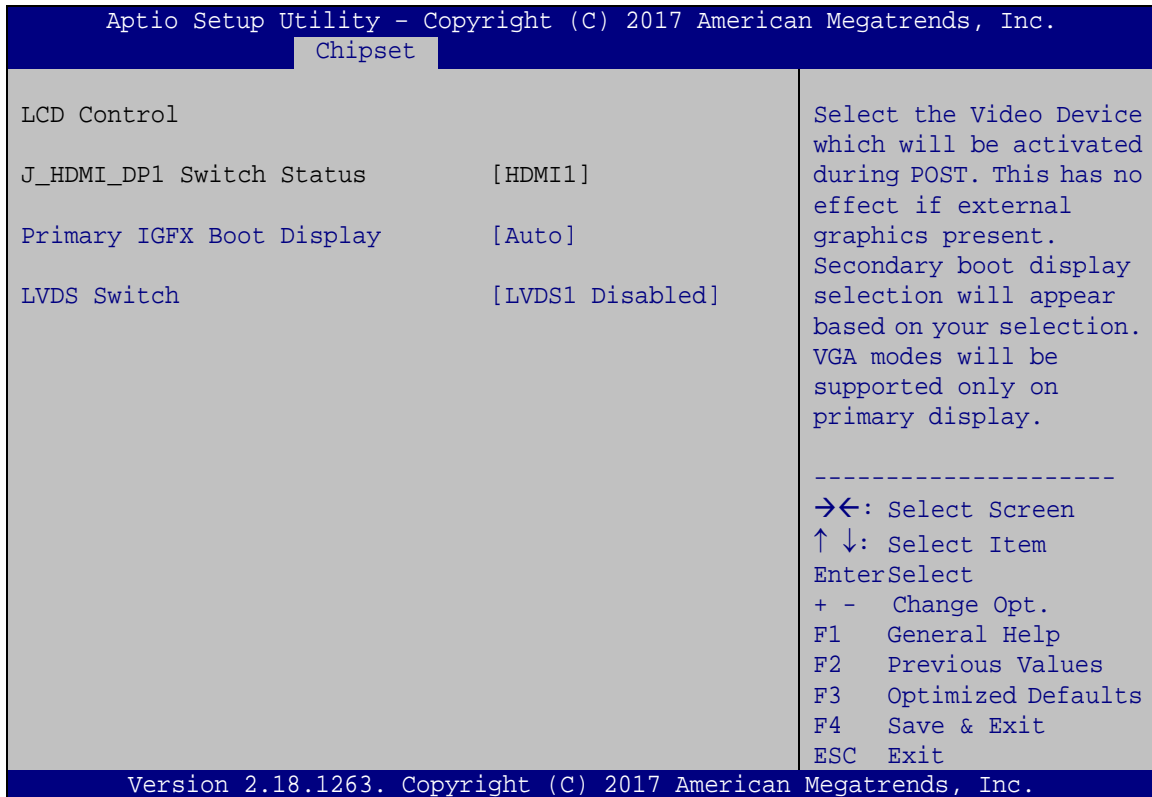

BIOS Menu 19: LCD Control

➔ Primary IGFX Boot Display [Auto]

Use the **Primary IGFX Boot Display** option to select the display device used by the system when it boots. Configuration options are listed below.

- Auto **DEFAULT**
- HDMI1/DP1
- LVDS1
- HDMI2

➔ **LVDS Switch [LVDS1 Disabled]**

Use the **LVDS Switch** option to enable or disable the on-board LVDS connector.

- ➔ **LVDS1 Disabled** **DEFAULT** The on-board LVDS connector is disabled.
- ➔ **LVDS1 Enabled** The on-board LVDS connector is enabled.

5.4.2 Southbridge Configuration

Use the **South Bridge** menu (**BIOS Menu 20**) to configure the Southbridge parameters.

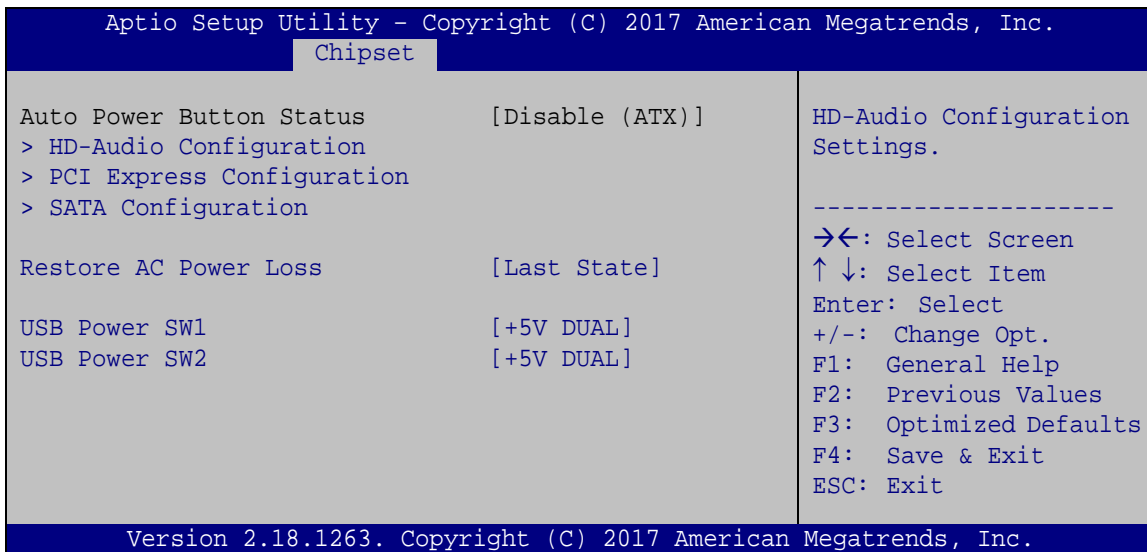

BIOS Menu 20: Southbridge Configuration

➔ **Restore AC Power Loss [Last State]**

Use the **Restore AC Power Loss** BIOS option to specify what state the system returns to if there is a sudden loss of power to the system.

- ➔ **Power Off** The system remains turned off
- ➔ **Power On** The system turns on
- ➔ **Last State** **DEFAULT** The system returns to its previous state. If it was on, it turns itself on. If it was off, it remains off.

NANO-AL EPIC SBC

➔ USB Power SW1 [+5V DUAL]

Use the **USB Power SW1** BIOS option to configure the USB power source for the corresponding USB connectors (**Table 5-2**).

➔ **+5V DUAL** **DEFAULT** Sets the USB power source to +5V dual

➔ **+5V** Sets the USB power source to +5V

➔ USB Power SW2 [+5V DUAL]

Use the **USB Power SW2** BIOS option to configure the USB power source for the corresponding USB connectors (**Table 5-2**).

➔ **+5V DUAL** **DEFAULT** Sets the USB power source to +5V dual

➔ **+5V** Sets the USB power source to +5V

BIOS Options	Configured USB Ports
USB Power SW1	USB3-1 (external USB 3.2 Gen 1 ports)
USB Power SW2	USB2-1 (external USB 2.0 ports) USB2-2 (internal USB 2.0 ports)

Table 5-2: BIOS Options and Configured USB Ports

5.4.2.1 HD Audio Configuration

Use the **HD-Audio Configuration** menu (**BIOS Menu 24**) to configure the PCH Azalia settings.

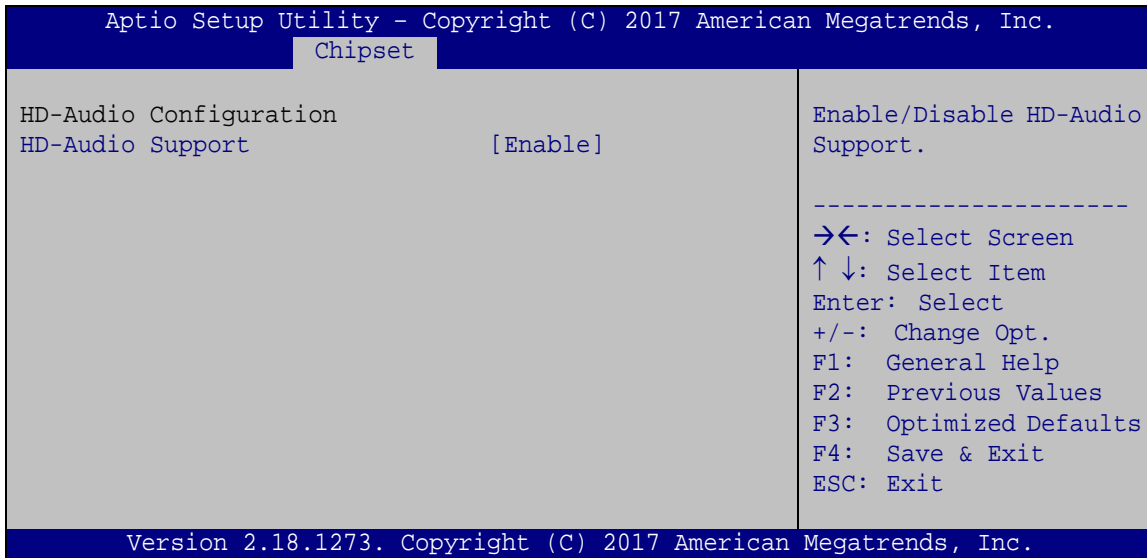

BIOS Menu 21: HD-Audio Configuration

➔ **HD-Audio Support [Enable]**

Use the **HD-Audio Support** BIOS option to enable or disable the High Definition Audio support.

- ➔ **Disable** Disables the High Definition Audio support.
- ➔ **Enable** **DEFAULT** Enables the High Definition Audio support.

NANO-AL EPIC SBC

5.4.2.2 PCI Express Configuration

Use the **PCI Express Configuration** menu (**BIOS Menu 24**) to configure the PCI Express root ports.

```
Aptio Setup Utility - Copyright (C) 2017 American Megatrends, Inc.
Chipset
PCI Express Configuration
> Onboard LAN1
> Onboard LAN2
> MPCIE1

Control the PCI Express Root Port.
AUTO: To disable unused root port automatically for the most optimum power savings.
Enable: Enable PCIe root port
Disable: Disable PCIe root port

-----
-><: Select Screen
↑ ↓: Select Item
Enter: Select
+/-: Change Opt.
F1: General Help
F2: Previous Values
F3: Optimized Defaults
F4: Save & Exit
ESC: Exit

Version 2.18.1263. Copyright (C) 2017 American Megatrends, Inc.
```

BIOS Menu 22: PCI Express Configuration

5.4.2.2.1 Onboard LAN1/Onboard LAN2

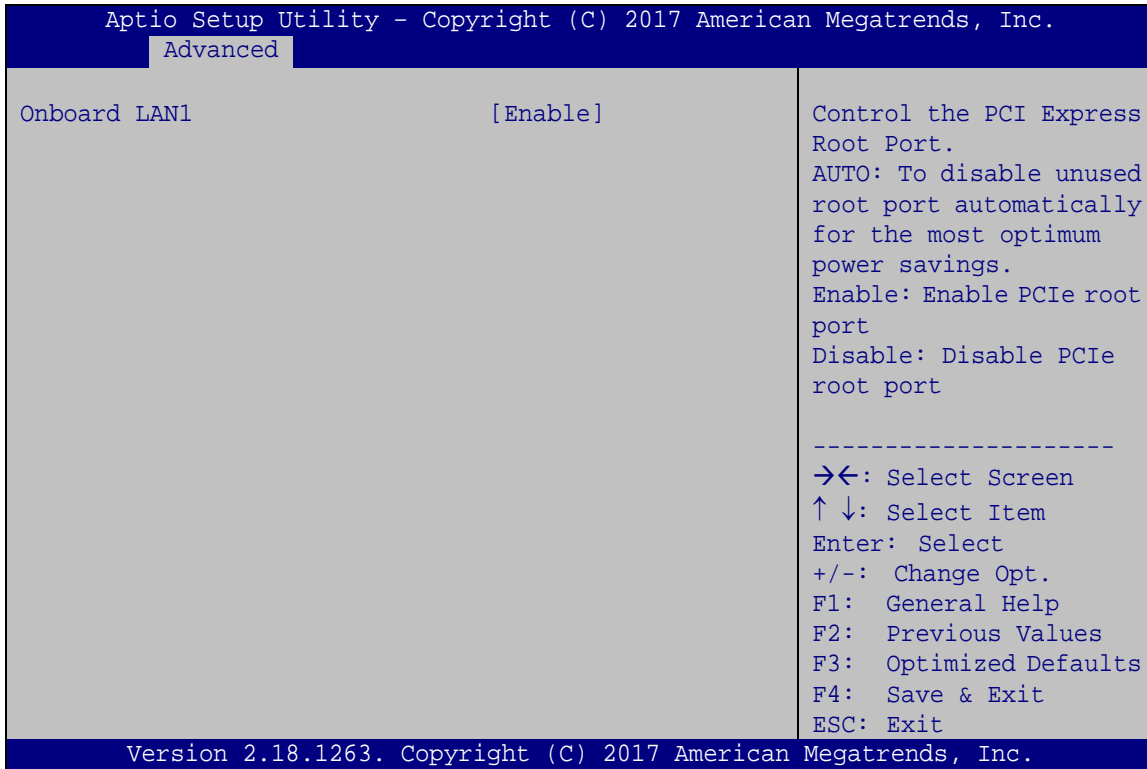

BIOS Menu 23: Onboard LAN1/Onboard LAN2 Configuration

➔ **Onboard LAN1/Onboard LAN2 [Enable]**

Use the **Onboard LAN1/Onboard LAN2** option to configure the LAN1/LAN2 port.

- ➔ **Disable** **DEFAULT** Disables the LAN port.
- ➔ **Enable** Enables the LAN port.
- ➔ **Auto** Automatically disables unused port for the most optimum power savings.

5.4.2.2.2 MPCIE1

Use the **MPCIE1** menu (**BIOS Menu 24**) to configure the PCIe Mini slot.

NANO-AL EPIC SBC

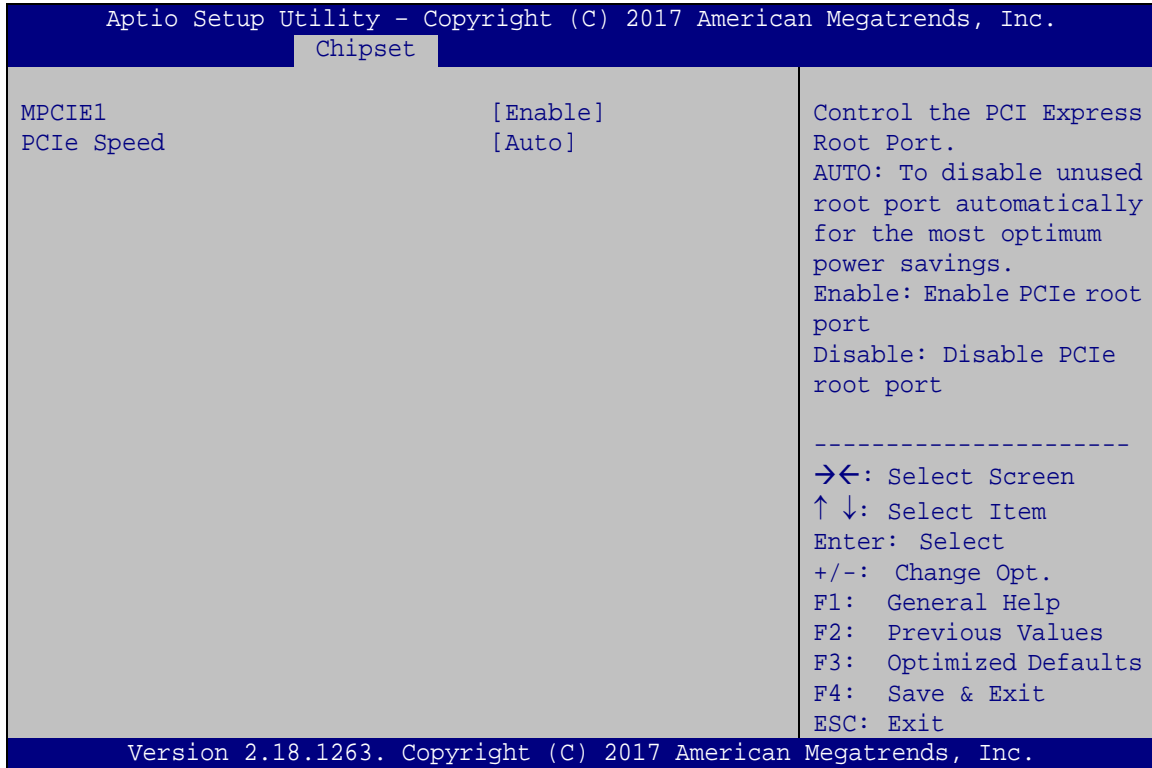

BIOS Menu 24: MPCIE1 Configuration

→ MPCIE1 [Enable]

Use the **MPCIE1** option to configure the PCIe Mini slot.

- **Disable** **DEFAULT** Disables PCIe Mini slot.
- **Enable** Enables PCIe Mini slot.
- **Auto** Automatically disables the unused slot for the most optimum power savings

→ PCIe Speed [Auto]

Use the **PCIe Speed** option to configure the PCIe Mini slot speed.

- Auto **DEFAULT**
- Gen 1
- Gen 2

5.4.2.3 SATA Configuration

Use the **SATA Configuration** menu (**BIOS Menu 25**) to change and/or set the configuration of the SATA devices installed in the system.

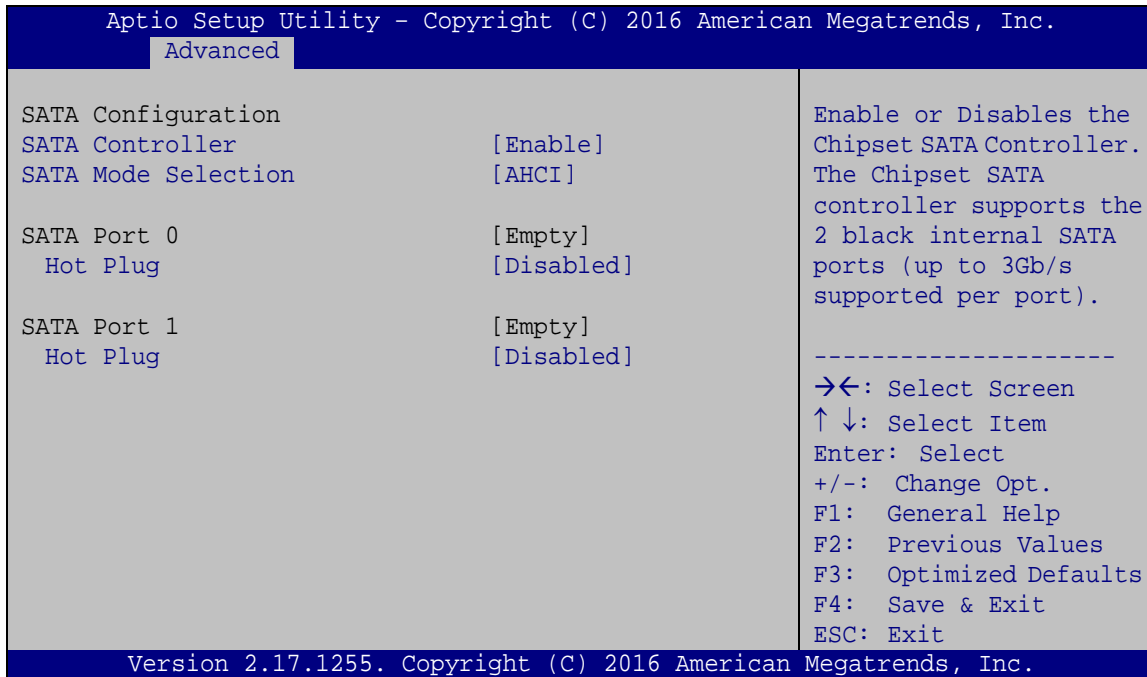

BIOS Menu 25: SATA Configuration

➔ SATA Controller [Enabled]

Use the **SATA Controller** option to configure the SATA controller.

- ➔ **Enabled** **DEFAULT** Enables the on-board SATA controller.
- ➔ **Disabled** Disables the on-board SATA controller.

➔ SATA Mode Selection [AHCI]

Use the **SATA Mode Selection** option to determine how the SATA devices operate.

- ➔ **AHCI** **DEFAULT** Configures SATA devices as AHCI device.

NANO-AL EPIC SBC

→ Hot Plug [Disabled]

Use the **Hot Plug** option to designate the correspondent SATA port as hot-pluggable.

- **Disabled** **DEFAULT** Disables the hot-pluggable function of the SATA port.
- **Enabled** Designates the SATA port as hot-pluggable.

5.5 Security

Use the **Security** menu (**BIOS Menu 26**) to set system and user passwords.

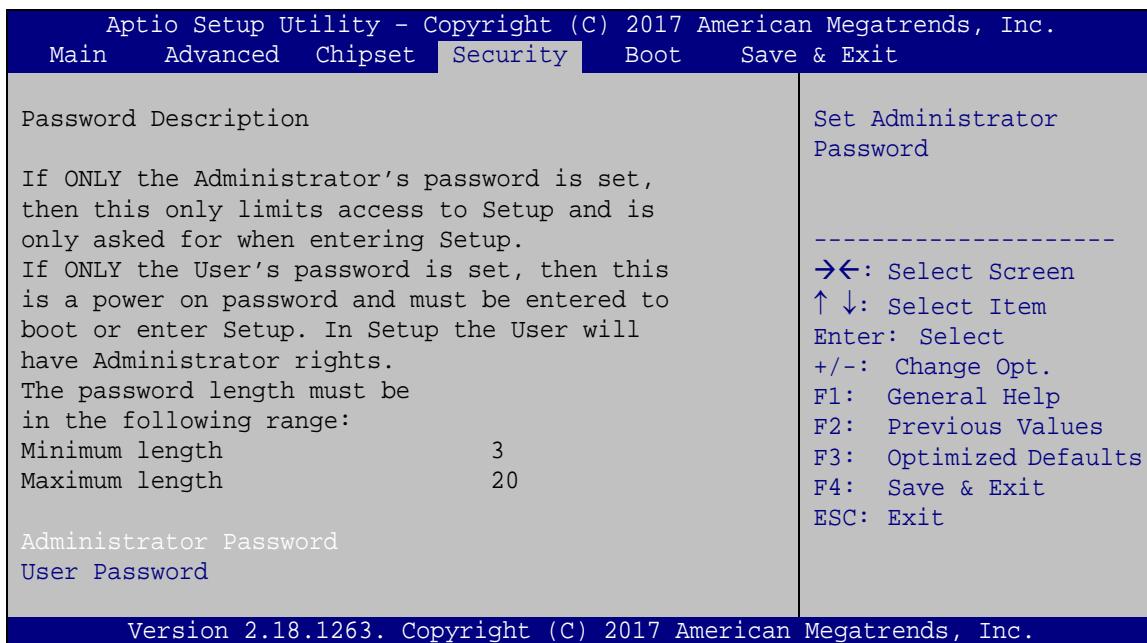

BIOS Menu 26: Security

→ Administrator Password

Use the **Administrator Password** to set or change an administrator password.

→ User Password

Use the **User Password** to set or change a user password.

5.6 Boot

Use the **Boot menu (BIOS Menu 27)** to configure system boot options.

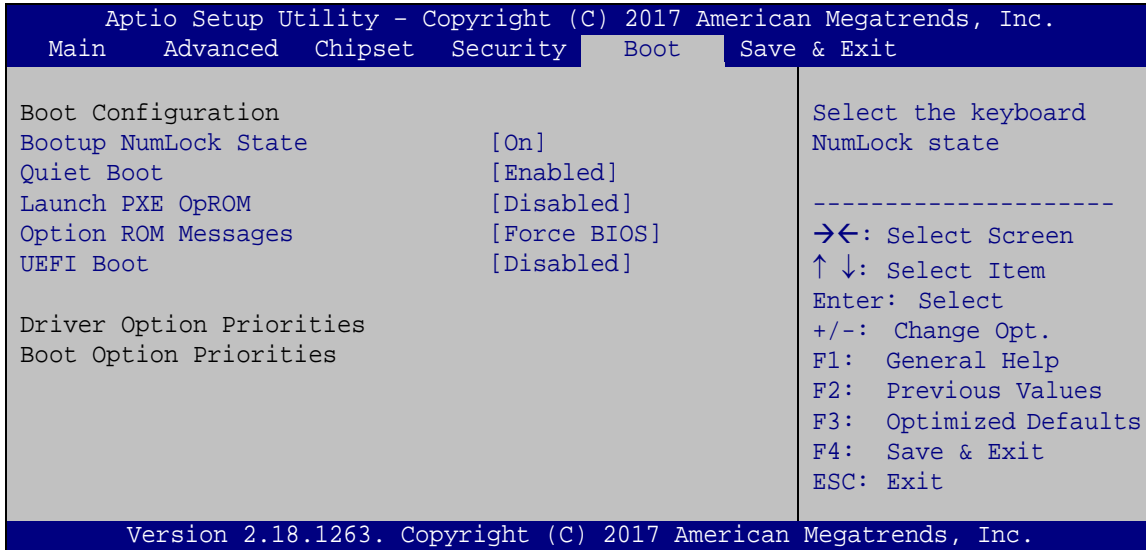

BIOS Menu 27: Boot

→ Bootup NumLock State [On]

Use the **Bootup NumLock State** BIOS option to specify if the number lock setting must be modified during boot up.

- **On** **DEFAULT** Allows the Number Lock on the keyboard to be enabled automatically when the computer system boots up. This allows the immediate use of the 10-key numeric keypad located on the right side of the keyboard. To confirm this, the Number Lock LED light on the keyboard is lit.

- **Off** Does not enable the keyboard Number Lock automatically. To use the 10-keys on the keyboard, press the Number Lock key located on the upper left-hand corner of the 10-key pad. The Number Lock LED on the keyboard lights up when the Number Lock is engaged.

NANO-AL EPIC SBC

→ Quiet Boot [Enabled]

Use the **Quiet Boot** BIOS option to select the screen display when the system boots.

- **Disabled** Normal POST messages displayed
- **Enabled** **DEFAULT** OEM Logo displayed instead of POST messages

→ Launch PXE OpROM [Disabled]

Use the **Launch PXE OpROM** option to enable or disable boot option for legacy network devices.

- **Disabled** **DEFAULT** Ignore all PXE Option ROMs
- **Enabled** Load PXE Option ROMs.

→ Option ROM Messages [Force BIOS]

Use the **Option ROM Messages** option to set the Option ROM display mode.

- **Force BIOS** **DEFAULT** Sets display mode to force BIOS.
- **Keep Current** Sets display mode to current.

→ UEFI Boot [Disabled]

Use the **UEFI Boot** BIOS option to allow the system to boot from the UEFI devices.

- **Disabled** **DEFAULT** Disables to boot from the UEFI devices.
- **Enabled** Enables to boot from the UEFI devices.

5.7 Save & Exit

Use the **Save & Exit** menu (**BIOS Menu 28**) to load default BIOS values, optimal failsafe values and to save configuration changes.

```

Aptio Setup Utility - Copyright (C) 2017 American Megatrends, Inc.
Main   Advanced  Chipset  Security  Boot   Save & Exit
-----
Save Changes and Reset
Discard Changes and Reset

Restore Defaults
Save as User Defaults
Restore User Defaults

Reset the system after
saving the changes.

-----
-><: Select Screen
↑ ↓: Select Item
Enter: Select
+/-: Change Opt.
F1: General Help
F2: Previous Values
F3: Optimized Defaults
F4: Save & Exit
ESC: Exit

Version 2.18.1263. Copyright (C) 2017 American Megatrends, Inc.

```

BIOS Menu 28: Save & Exit

➔ Save Changes and Reset

Use the **Save Changes and Reset** option to save the changes made to the BIOS options and reset the system.

➔ Discard Changes and Reset

Use the **Discard Changes and Reset** option to exit the system without saving the changes made to the BIOS configuration setup program.

➔ Restore Defaults

Use the **Restore Defaults** option to load the optimal default values for each of the parameters on the Setup menus. **F3 key can be used for this operation.**

➔ Save as User Defaults

Use the **Save as User Defaults** option to save the changes done so far as user defaults.

➔ Restore User Defaults

Use the **Restore User Defaults** option to restore the user defaults to all the setup options.

Appendix

A

Regulatory Compliance

DECLARATION OF CONFORMITY

This equipment has been tested and found to comply with specifications for CE marking. If the user modifies and/or installs other devices in the equipment, the CE conformity declaration may no longer apply.

FCC WARNING

This equipment complies with Part 15 of the FCC Rules. Operation is subject to the following two conditions:

- This device may not cause harmful interference, and
- This device must accept any interference received, including interference that may cause undesired operation.

This equipment has been tested and found to comply with the limits for a Class A digital device, pursuant to part 15 of the FCC Rules. These limits are designed to provide reasonable protection against harmful interference when the equipment is operated in a commercial environment. This equipment generates, uses, and can radiate radio frequency energy and, if not installed and used in accordance with the instruction manual, may cause harmful interference to radio communications. Operation of this equipment in a residential area is likely to cause harmful interference in which case the user will be required to correct the interference at his own expense.

Appendix

B

Product Disposal

**CAUTION:**

Risk of explosion if battery is replaced by an incorrect type. Only certified engineers should replace the on-board battery.

Dispose of used batteries according to instructions and local regulations.

- Outside the European Union – If you wish to dispose of used electrical and electronic products outside the European Union, please contact your local authority so as to comply with the correct disposal method.
- Within the European Union – The device that produces less waste and is easier to recycle is classified as electronic device in terms of the European Directive 2012/19/EU (WEEE), and must not be disposed of as domestic garbage.

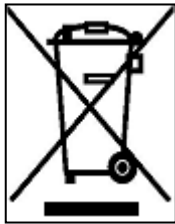

EU-wide legislation, as implemented in each Member State, requires that waste electrical and electronic products carrying the mark (left) must be disposed of separately from normal household waste. This includes monitors and electrical accessories, such as signal cables or power cords. When you need to dispose of your device, please follow the guidance of your local authority, or ask the shop where you purchased the product. The mark on electrical and electronic products only applies to the current European Union Member States.

Please follow the national guidelines for electrical and electronic product disposal.

Appendix

C

BIOS Options

Below is a list of BIOS configuration options in the BIOS chapter.

<input type="checkbox"/>	System Date [xx/xx/xx]	80
<input type="checkbox"/>	System Time [xx:xx:xx]	80
<input type="checkbox"/>	Security Device Support [Disable]	82
<input type="checkbox"/>	ACPI Sleep State [S3 (Suspend to RAM)]	83
<input type="checkbox"/>	Serial Port [Enabled]	85
<input type="checkbox"/>	Change Settings [Auto]	85
<input type="checkbox"/>	Serial Port [Enabled]	85
<input type="checkbox"/>	Change Settings [Auto]	86
<input type="checkbox"/>	Serial Port [Enabled]	86
<input type="checkbox"/>	Change Settings [Auto]	86
<input type="checkbox"/>	Serial Port [Enabled]	87
<input type="checkbox"/>	Change Settings [Auto]	87
<input type="checkbox"/>	Serial Port [Enabled]	88
<input type="checkbox"/>	Change Settings [Auto]	88
<input type="checkbox"/>	Transfer Mode [RS232]	88
<input type="checkbox"/>	Serial Port [Enabled]	89
<input type="checkbox"/>	Change Settings [Auto]	89
<input type="checkbox"/>	Transfer Mode [RS232]	89
<input type="checkbox"/>	PC Health Status	90
<input type="checkbox"/>	CPU_FAN1 Smart Fan Control [Manual Mode]	91
<input type="checkbox"/>	Manual Mode [70]	91
<input type="checkbox"/>	USB Devices	92
<input type="checkbox"/>	Legacy USB Support [Enabled]	92
<input type="checkbox"/>	EIST [Enabled]	94
<input type="checkbox"/>	C-States [Disabled]	94
<input type="checkbox"/>	Intel Virtualization Technology [Disabled]	94
<input type="checkbox"/>	VT-d [Disabled]	94
<input type="checkbox"/>	Wake system with Fixed Time [Disabled]	95
<input type="checkbox"/>	Power Saving Function(ERP) [Disabled]	96
<input type="checkbox"/>	Console Redirection [Disabled]	97
<input type="checkbox"/>	Terminal Type [ANSI]	98
<input type="checkbox"/>	Bits per second [115200]	98
<input type="checkbox"/>	Data Bits [8]	98

NANO-AL EPIC SBC

<input type="checkbox"/>	Parity [None].....	99
<input type="checkbox"/>	Stop Bits [1].....	99
<input type="checkbox"/>	Legacy Serial Redirection Port [COM1].....	100
<input type="checkbox"/>	Auto Recovery Function [Disabled].....	101
<input type="checkbox"/>	Primary Display [IGD].....	103
<input type="checkbox"/>	Integrated Graphics Device [Enable].....	103
<input type="checkbox"/>	DVMT Pre-Allocated [256M].....	104
<input type="checkbox"/>	DVMT Total Gfx Mem [MAX].....	104
<input type="checkbox"/>	Primary IGFX Boot Display [Auto].....	105
<input type="checkbox"/>	LVDS Switch [LVDS1 Disabled].....	106
<input type="checkbox"/>	Restore AC Power Loss [Last State].....	106
<input type="checkbox"/>	USB Power SW1 [+5V DUAL].....	107
<input type="checkbox"/>	USB Power SW2 [+5V DUAL].....	107
<input type="checkbox"/>	HD-Audio Support [Enable].....	108
<input type="checkbox"/>	Onboard LAN1/Onboard LAN2 [Enable].....	110
<input type="checkbox"/>	MPCIE1 [Enable].....	111
<input type="checkbox"/>	PCIe Speed [Auto].....	111
<input type="checkbox"/>	SATA Controller [Enabled].....	112
<input type="checkbox"/>	SATA Mode Selection [AHCI].....	112
<input type="checkbox"/>	Hot Plug [Disabled].....	113
<input type="checkbox"/>	Administrator Password.....	113
<input type="checkbox"/>	User Password.....	113
<input type="checkbox"/>	Bootup NumLock State [On].....	114
<input type="checkbox"/>	Quiet Boot [Enabled].....	115
<input type="checkbox"/>	Launch PXE OpROM [Disabled].....	115
<input type="checkbox"/>	Option ROM Messages [Force BIOS].....	115
<input type="checkbox"/>	UEFI Boot [Disabled].....	115
<input type="checkbox"/>	Save Changes and Reset.....	116
<input type="checkbox"/>	Discard Changes and Reset.....	116
<input type="checkbox"/>	Restore Defaults.....	116
<input type="checkbox"/>	Save as User Defaults.....	116
<input type="checkbox"/>	Restore User Defaults.....	116

Appendix

D

Digital I/O Interface

NANO-AL EPIC SBC

The DIO connector on the NANO-AL is interfaced to GPIO ports on the Super I/O chipset. The digital inputs and digital outputs are generally control signals that control the on/off circuit of external devices or TTL devices. Data can be read or written to the selected address to enable the DIO functions.



NOTE:

For further information, please refer to the datasheet for the Super I/O chipset.

The BIOS interrupt call **INT 15H** controls the digital I/O.

INT 15H:

AH – 6FH	
<u>Sub-function:</u>	
AL – 8	: Set the digital port as INPUT
AL	: Digital I/O input value

Assembly Language Sample 1

```
MOV    AX, 6F08H    ; setting the digital port as input
INT    15H        ;
```

AL low byte = value

AH – 6FH
<u>Sub-function:</u>
AL – 9 : Set the digital port as OUTPUT
BL : Digital I/O output value

Assembly Language Sample 2

MOV AX, 6F09H ; setting the digital port as output

MOV BL, 09H ; digital value is 09H

INT 15H ;

Digital Output is 1001b

Appendix

E

Error Beep Code

E.1 PEI Beep Codes

Number of Beeps	Description
1	Memory not Installed
1	Memory was installed twice (InstallPeiMemory routine in PEI Core called twice)
2	Recovery started
3	DXE IPL was not found
3	DXE Core Firmware Volume was not found
4	Recovery failed
4	S3 Resume failed
7	Reset PPI is not available

E.2 DXE Beep Codes

Number of Beeps	Description
1	Invalid password
4	Some of the Architectural Protocols are not available
5	No Console Output Devices are found
5	No Console Input Devices are found
6	Flash update is failed
7	Reset protocol is not available
8	Platform PCI resource requirements cannot be met



NOTE:

If you have any question, please contact IEI for further assistance.

Appendix

F

Hazardous Materials Disclosure

F.1 RoHS II Directive (2015/863/EU)

The details provided in this appendix are to ensure that the product is compliant with the RoHS II Directive (2015/863/EU). The table below acknowledges the presences of small quantities of certain substances in the product, and is applicable to RoHS II Directive (2015/863/EU).

Please refer to the following table.

Part Name	Toxic or Hazardous Substances and Elements									
	Lead (Pb)	Mercury (Hg)	Cadmium (Cd)	Hexavalent Chromium (CR(VI))	Polybrominated Biphenyls (PBB)	Polybrominated Diphenyl Ethers (PBDE)	Bis(2-ethylhexyl) phthalate (DEHP)	Butyl benzyl phthalate (BBP)	Dibutyl phthalate (DBP)	Diisobutyl phthalate (DIBP)
Housing	O	O	O	O	O	O	O	O	O	O
Display	O	O	O	O	O	O	O	O	O	O
Printed Circuit Board	O	O	O	O	O	O	O	O	O	O
Metal Fasteners	O	O	O	O	O	O	O	O	O	O
Cable Assembly	O	O	O	O	O	O	O	O	O	O
Fan Assembly	O	O	O	O	O	O	O	O	O	O
Power Supply Assemblies	O	O	O	O	O	O	O	O	O	O
Battery	O	O	O	O	O	O	O	O	O	O

O: This toxic or hazardous substance is contained in all of the homogeneous materials for the part is below the limit requirement in Directive (EU) 2015/863.

X: This toxic or hazardous substance is contained in at least one of the homogeneous materials for this part is above the limit requirement in Directive (EU) 2015/863.

NANO-AL EPIC SBC

F.2 China RoHS

此附件旨在确保本产品符合中国 RoHS 标准。以下表格标示此产品中某有毒物质的含量符合中国 RoHS 标准规定的限量要求。

本产品上会附有“环境友好使用期限”的标签，此期限是估算这些物质“不会有泄漏或突变”的年限。本产品可能包含有较短的环境友好使用期限的可替换元件，像是电池或灯管，这些元件将会单独标示出来。

部件名称	有毒有害物质或元素					
	铅 (Pb)	汞 (Hg)	镉 (Cd)	六价铬 (CR(VI))	多溴联苯 (PBB)	多溴二苯醚 (PBDE)
壳体	○	○	○	○	○	○
显示	○	○	○	○	○	○
印刷电路板	○	○	○	○	○	○
金属螺帽	○	○	○	○	○	○
电缆组装	○	○	○	○	○	○
风扇组装	○	○	○	○	○	○
电力供应组装	○	○	○	○	○	○
电池	○	○	○	○	○	○

○: 表示该有毒有害物质在该部件所有物质材料中的含量均在 SJ/T11364-2014 與 GB/T26572-2011 标准规定的限量要求以下。

X: 表示该有毒有害物质至少在该部件的某一均质材料中的含量超出 SJ/T11364-2014 與 GB/T26572-2011 标准规定的限量要求。