

SATADOM-SV

3IE4 Series

Customer: _____
Customer
Part Number: _____
Innodisk
Part Number: _____
Innodisk
Model Name: _____
Date: _____

Innodisk Approver	Customer Approver

**Total Solution For
Industrial Flash Storage**

Table of contents

1. PRODUCT OVERVIEW	7
1.1 INTRODUCTION OF INNODISK SATADOM-SV 3IE4 SERIES	7
1.2 PRODUCT VIEW AND MODELS	7
1.3 SATA INTERFACE	7
2. PRODUCT SPECIFICATIONS	8
2.1 CAPACITY AND DEVICE PARAMETERS	8
2.2 PERFORMANCE	8
2.3 ELECTRICAL SPECIFICATIONS	8
2.3.1 Power Requirement	8
2.4 ENVIRONMENTAL SPECIFICATIONS	9
2.4.1 Temperature Ranges	9
2.4.2 Humidity	9
2.4.3 Shock and Vibration	9
2.4.4 Mean Time between Failures (MTBF)	9
2.5 CE AND FCC COMPATIBILITY	10
2.6 RoHS COMPLIANCE	10
2.8 TRANSFER MODE	10
2.9 PIN ASSIGNMENT	11
2.10 MECHANICAL DIMENSIONS	11
2.11 ASSEMBLY WEIGHT	12
2.12 SEEK TIME	12
2.13 HOT PLUG	12
2.14 NAND FLASH MEMORY	12
3. THEORY OF OPERATION	13
3.1 OVERVIEW	13
3.2 SATA III CONTROLLER	13
3.3 ERROR DETECTION AND CORRECTION	13
3.4 WEAR-LEVELING	14
3.5 BAD BLOCKS MANAGEMENT	14
3.6 iDATA GUARD	14
3.7 GARBAGE COLLECTION	14
3.8 TRIM	14
4. INSTALLATION REQUIREMENTS	15
4.1 SATADOM-SV 3IE4 PIN DIRECTIONS	15
4.2 ELECTRICAL CONNECTIONS FOR SATADOM-SV 3IE4	15
4.3 DEVICE DRIVE	15
4.4 POWER SUPPLY FOR SATADOM	15

4.4.1 Power Cable	15
4.4.2 Pin8 and Pin7 VCC	16
5. PART NUMBER RULE	17
6. APPENDIX	18

REVISION HISTORY

Revision	Description	Date
V1.0	First Released	Mar., 2017
V1.1	Add SATADOM-SV 3IE4 BGA capacity	Dec., 2017
V1.2	Performance/power consumption update	Jan., 2018
V1.3	Update TRIM/RoHS/REACH	Aug., 2019
V1.4	Update Product Photo & Mechanical Drawing	Apr., 2024

List of Tables

TABLE 1: DEVICE PARAMETERS	8
TABLE 2: PERFORMANCE	8
TABLE 3: INNODISK SATADOM-SV 3IE4 POWER REQUIREMENT	8
TABLE 4: POWER CONSUMPTION	9
TABLE 5: TEMPERATURE RANGE FOR SATADOM-SV 3IE4	9
TABLE 6: SHOCK/VIBRATION TESTING FOR SATADOM-SV 3IE4	9
TABLE 7: SATADOM-SV 3IE4 MTBF	10
TABLE 8: SATADOM-SV 3IE4 TBW	10
TABLE 9: INNODISK SATADOM-SV 3IE4 PIN ASSIGNMENT	11

List of Figures

FIGURE 1: INNODISK SATADOM-SV 3IE4	7
FIGURE 2: INNODISK SATADOM-SV 3IE4 MECHANICAL DIAGRAM	11
FIGURE 3: INNODISK SATADOM-SV 3IE4 BLOCK DIAGRAM	13
FIGURE 4: SIGNAL SEGMENT AND POWER SEGMENT	15
FIGURE 5: STANDARD POWER CABLE	15
FIGURE 6: PIN 8 / PIN 7 HOST DESIGN IN REFERENCE CIRCUIT	16

1. Product Overview

1.1 Introduction of Innodisk SATADOM-SV 3IE4 Series

Innodisk SATADOM-SV 3IE4 is characterized by L³ architecture with the latest SATA III (6.0GHz) Marvell NAND controller. Innodisk's exclusive L³ architecture is L² architecture multiplied LDPC (Low Density Parity Check). L² (Long Life) architecture is a 4K mapping algorithm that reduces WAF and features a real-time wear leveling algorithm to provide high performance and prolong lifespan with exceptional reliability. Innodisk SATADOM-SV 3IE4 is designed for industrial field, and supports several standard features, including TRIM, NCQ, and S.M.A.R.T. In addition, Innodisk's exclusive industrial-oriented firmware provides a flexible customization service, making it perfect for a variety of industrial applications.

CAUTION TRIM must be enabled.

TRIM enables SSD's controller to skip invalid data instead of moving. It can free up significant amount of resources, extends the lifespan of SSD by reducing erase, and write cycles on the SSD. Innodisk's handling of garbage collection along with TRIM command improves write performance on SSDs.

1.2 Product View and Models

Innodisk SATADOM-SV 3IE4 is available in follow capacities within MLC flash ICs in iSLC mode.

[SATADOM-SV 3IE4 8GB~64GB](#)



Figure 1: Innodisk SATADOM-SV 3IE4

1.3 SATA Interface

Innodisk SATADOM-SV 3IE4 supports SATA III interface, and compliant with SATA I and SATA II.

2. Product Specifications

2.1 Capacity and Device Parameters

SATADOM-SV 3IE4 device parameters are shown in Table 1.

Table 1: Device Parameters

Capacity	Cylinders	Heads	Sectors	LBA	User Capacity(MB)
8GB	15525	16	63	15649200	7641
16GB	16383	16	63	31277232	15272
32GB	16383	16	63	62533296	30533
64GB	16383	16	63	125045424	61057

2.2 Performance

Burst Transfer Rate: 6.0Gbps

Table 2: Performance

Capacity	8GB	16GB	32GB(1CH)	32GB(2CH)	64GB
Sequential* Read (max.)	250 MB/s	340 MB/s	340 MB/s	530 MB/s	530 MB/s
Sequential* Write (max.)	80 MB/s	160 MB/s	230 MB/s	300 MB/s	350 MB/s
4KB Random** Read (QD32)	12,000 IOPS	17,000 IOPS	22,000 IOPS	31,100 IOPS	31,700 IOPS
4KB Random** Write (QD32)	12,000 IOPS	26,000 IOPS	29,000 IOPS	30,100 IOPS	30,500 IOPS

Note: * Sequential performance is based on CrystalDiskMark 5.1.2 with file size 1000MB

** Random performance is based on IO meter with Queue Depth 32

2.3 Electrical Specifications

2.3.1 Power Requirement

Table 3: Innodisk SATADOM-SV 3IE4 Power Requirement

Item	Symbol	Rating	Unit
Input voltage	V _{IN}	+5 DC +- 5%	V

2.3.2 Power Consumption

Table 4: Power Consumption

Mode	Power Consumption(mA)
Read	202mA (max.)
Write	257mA (max.)
Idle	89mA (max.)
Pin 7/ Pin8 VCC Initial*	1000mA (max.)

Target: SATADOM-SV 3IE4 64GB

***To design in Pin7/8 VCC on motherboard, 5V with 1A power supply is requested.**

2.4 Environmental Specifications

2.4.1 Temperature Ranges

Table 5: Temperature range for SATADOM-SV 3IE4

Temperature	Range
Operating	Standard Grade: 0°C to +70°C
	Industrial Grade: -40°C to +85°C
Storage	-55°C to +95°C

2.4.2 Humidity

Relative Humidity: 10-95%, non-condensing

2.4.3 Shock and Vibration

Table 6: Shock/Vibration Testing for SATADOM-SV 3IE4

Reliability	Test Conditions	Reference Standards
Vibration	7 Hz to 2K Hz, 20G, 3 axes	IEC 60068-2-6
Mechanical Shock	Duration: 0.5ms, 1500 G, 3 axes	IEC 60068-2-27

2.4.4 Mean Time between Failures (MTBF)

Table 7 summarizes the MTBF prediction results for various SATADOM-SV 3IE4 configurations. The analysis was performed using a RAM Commander™ failure rate prediction.

- **Failure Rate:** The total number of failures within an item population, divided by the total number of life units expended by that population, during a particular measurement interval under stated condition.
- **Mean Time between Failures (MTBF):** A basic measure of reliability for repairable items: The mean number of life units during which all parts of the item perform within their specified limits, during a particular measurement interval under stated conditions.

Table 7: SATADOM-SV 3IE4 MTBF

Product	Condition	MTBF (Hours)
Innodisk SATADOM-SV 3IE4	Telcordia SR-332 GB, 25°C	>3,000,000

2.5 CE and FCC Compatibility

SATADOM-SV 3IE4 conforms to CE and FCC requirements.

2.6 RoHS Compliance

SATADOM-SV 3IE4 is fully compliant with RoHS directive.

2.7 Reliability

Table 8: SATADOM-SV 3IE4 TBW

Parameter		Value
Read Cycles		Unlimited Read Cycles
Flash endurance		20,000 P/E cycles
Wear-Leveling Algorithm		Support
Bad Blocks Management		Support
Error Correct Code		Support
TBW* (Total Bytes Written)		
Capacity	Sequential workload	Client workload
08GB	156.3	104.2
16GB	312.5	208.3
32GB	625.0	416.7
64GB	1250.0	833.3
* Note:		
<ol style="list-style-type: none"> 1. Sequential: Mainly sequential write, tested by Vdbench. 2. Client: Follow JESD218 Test method and JESD219A Workload, tested by ULINK. (The capacity lower than 64GB client workload is not specified in JEDEC219A, the values are estimated.) 3. Based on out-of-box performance. 		

2.8 Transfer Mode

SATADOM-SV 3IE4 support following transfer mode:

Serial ATA I 1.5Gbps

Serial ATA II 3.0Gbps

Serial ATA III 6.0Gbps

2.9 Pin Assignment

Innodisk SATADOM-SV 3IE4 uses a standard SATA pin-out. See Table 9 for SATADOM-SV 3IE4 pin assignment.

Table 9: Innodisk SATADOM-SV 3IE4 Pin Assignment

Name	Type	Description
Pin 0	GND	Shielding
Pin 1	GND	Shielding
Pin 2	A+	Differential signal to A
Pin 3	A-	Differential signal to A-
Pin 4	GND	Shielding
Pin 5	B-	Differential signal to B-
Pin 6	B+	Differential signal to B
Pin 7	GND/ Vcc*	Shielding/ +5V Power*
Pin 8	VCC	+5V Power

* SATADOM-SV 3IE4 default power supply through pin 8 or extra power cable.

Pin 7 power supply as an optional function with separated PN end of B.

2.10 Mechanical Dimensions

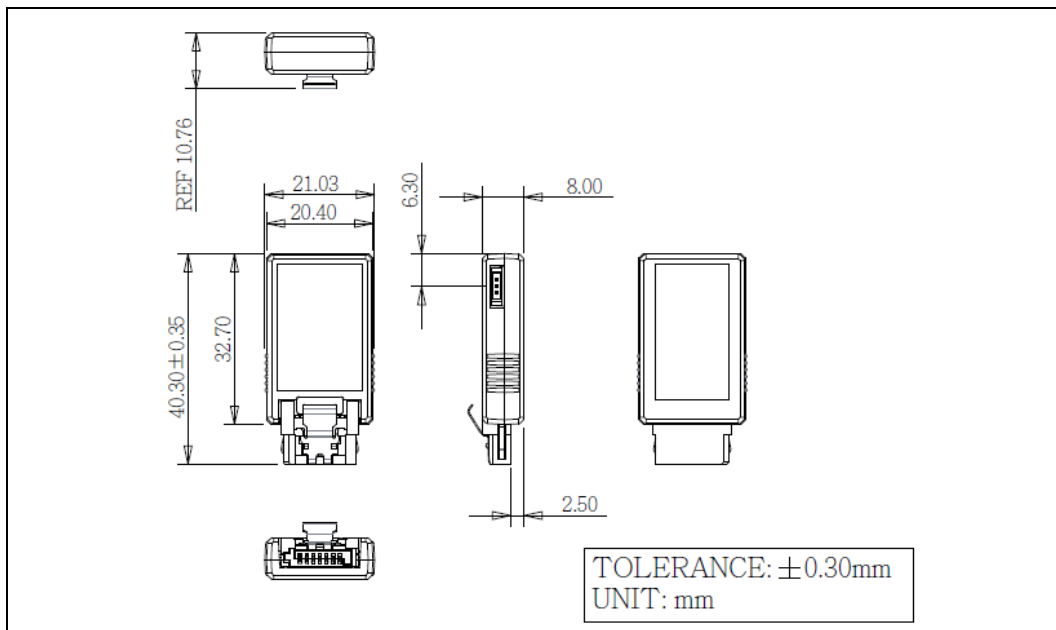

Figure 2: Innodisk SATADOM-SV 3IE4 Mechanical Diagram

2.11 Assembly Weight

An Innodisk SATADOM-SV 3IE4 within flash ICs, 32GB's weight is 7 grams approximately.

2.12 Seek Time

Innodisk SATADOM-SV 3IE4 is not a magnetic rotating design. There is no seek or rotational latency required.

2.13 Hot Plug

The SSD support hot plug function and can be removed or plugged-in during operation. User has to avoid hot plugging the SSD which is configured as boot device and installed operation system.

Surprise hot plug : The insertion of a SATA device into a backplane (combine signal and power) that has power present. The device powers up and initiates an OOB sequence.

Surprise hot removal: The removal of a SATA device from a powered backplane, without first being placed in a quiescent state.

2.14 NAND Flash Memory

Innodisk SATADOM-SV 3IE4 designed by iSLC. Through the use of flash management algorithms, iSLC improves SSD endurance and increasing lifespans up to 7 times longer than MLC-based solutions. In addition, iSLC improves the performance of solid state drives, with similar write performance of SLC-based solutions, and with data quality that is on par with SLC technologies.

3. Theory of Operation

3.1 Overview

Figure 3 shows the operation of Innodisk SATADOM-SV 3IE4 from the system level, including the major hardware blocks.

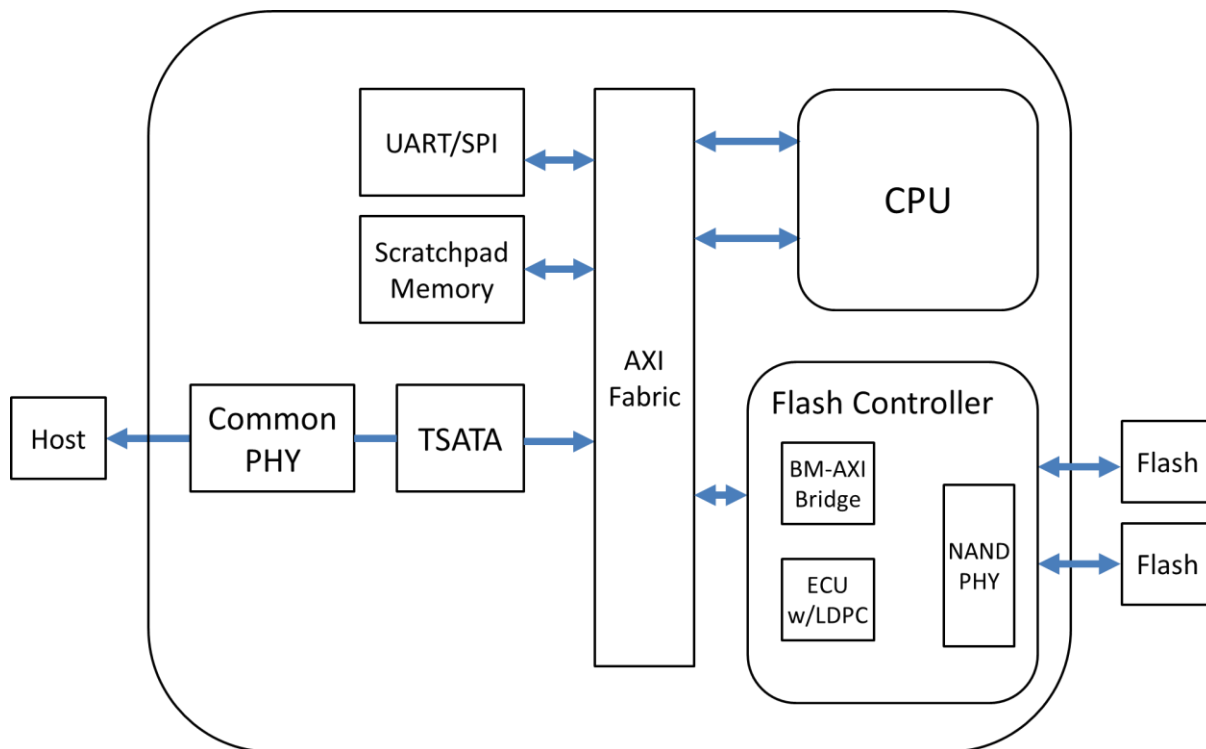

Figure 3: Innodisk SATADOM-SV 3IE4 Block Diagram

Innodisk SATADOM-SV 3IE4 integrates a SATA III controller and NAND flash memories. Communication with the host occurs through the host interface, using the standard ATA protocol. Communication with the flash device(s) occurs through the flash interface.

3.2 SATA III Controller

Innodisk SATADOM-SV 3IE4 is designed with 88NV1120, a SATA III 6.0Gbps (Gen. 3) controller. The Serial ATA physical, link and transport layers are compliant with Serial ATA Gen 1, Gen 2 and Gen 3 specification (Gen 3 supports 1.5Gbps/3.0Gbps/6.0Gbps data rate). The controller has 2 channels for flash interface.

3.3 Error Detection and Correction

Innodisk SATADOM-SV 3IE4 is designed with hardware LDPC ECC engine with hard-decision and soft-decision decoding. Low-density parity-check (LDPC) codes have excellent error correcting performance close to the Shannon limit when decoded with the belief-propagation (BP) algorithm using soft-decision information.

3.4 Wear-Leveling

Flash memory can be erased within a limited number of times. This number is called the **erase cycle limit** or **write endurance limit** and is defined by the flash array vendor. The erase cycle limit applies to each individual erase block in the flash device.

Innodisk SATADOM-ML 3IE4 uses a static wear-leveling algorithm to ensure that consecutive writes of a specific sector are not written physically to the same page/block in the flash. This spreads flash media usage evenly across all pages, thereby extending flash lifetime.

3.5 Bad Blocks Management

Bad Blocks are blocks that contain one or more invalid bits whose reliability are not guaranteed. The Bad Blocks may be presented while the SSD is shipped, or may develop during the life time of the SSD. When the Bad Blocks is detected, it will be flagged, and not be used anymore. The SSD implement Bad Blocks management, Bad Blocks replacement, Error Correct Code to avoid data error occurred. The functions will be enabled automatically to transfer data from Bad Blocks to spare blocks, and correct error bit.

3.6 iData Guard

Innodisk's power cycling management is a comprehensive data protection mechanism that functions before and after a sudden power outage to SSD. Low-power detection terminates data writing before an abnormal power-off, while table-remapping after power-on deletes corrupt data and maintains data integrity. Innodisk's power cycling provides effective power cycling management, preventing data stored in flash from degrading with use.

3.7 Garbage Collection

Garbage collection is used to maintain data consistency and perform continual data cleansing on SSDs. It runs as a background process, freeing up valuable controller resources while sorting good data into available blocks, and deleting bad blocks. It also significantly reduces write operations to the drive, thereby increasing the SSD's speed and lifespan.

3.8 TRIM

The TRIM command is designed to enable the operating system to notify the SSD which pages no longer contain valid data due to erases either by the user or operating system itself. During a delete operation, the OS will mark the sectors as free for new data and send a TRIM command to the SSD to mark them as not containing valid data. After that the SSD knows not to preserve the contents of the block when writing a page, resulting in less write amplification with fewer writes to the flash, higher write speed, and increased drive life.

4. Installation Requirements

4.1 SATADOM-SV 3IE4 Pin Directions

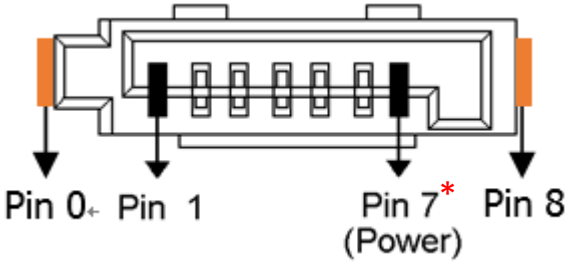

Figure 4: Signal Segment and Power Segment

* SATADOM-SV 3IE4 default power supply through pin 8 or extra power cable.
Pin 7 power supply as an optional function with separate PN end of B.

4.2 Electrical Connections for SATADOM-SV 3IE4

A Serial ATA device may be either directly connected to a host or connected to a host through a cable. For connection via cable, the cable should be no longer than 1 meter. The SATA interface has a separate connector for the power supply. Please refer to the pin description for further details.

4.3 Device Drive

No additional device drives are required. The Innodisk SATADOM-SV 3IE4 can be configured as a boot device.

4.4 Power Supply for SATADOM

4.4.1 Power Cable

A power cable is shipped with each SATADOM product, which has standard 4 pins power connector and special 3 pins power connector for SATADOM. The male and female power connector of SATADOM have foolproof design to avoid misconnection, please check it before power on. Innodisk also can customize the power connector for different host power socket design.

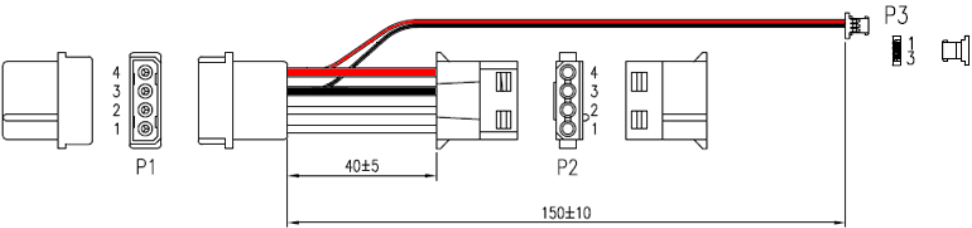

Figure 5: Standard power cable

4.4.2 Pin8 and Pin7 VCC

Innodisk’s SATADOM SSDs provide an elegant, compact option for SSD storage in embedded systems, industrial PCs and server motherboards with their small form factor that connects directly to the SATA connector on the motherboard. This simplified SSD design not only frees up a precious drive bay for other storage options but eliminates messy, obtrusive SATA data cabling. Innodisk’s patented Pin7 and Pin 8 SATA Power technologies take the cable-less concept to the next step by also eliminating the need for power cables for a 100% cable-less, shock resistant, space saving plug-and-play storage solution that optimizes airflow and makes the best use of limited board space in embedded and rackmount server systems.

SATADOM-SV 3IE4 series with Pin8/Pin7 VCC, it is defined Pin8/Pin7 as VCC on the SATA connector. Thus the power would come from SATA connector Pin8/Pin7 VCC. Customers DO NOT have to use the power cable for power supply. Such a cable-less design of SATADOM-SV 3IE4 series with Pin8/Pin7 VCC brings more convenience to customers’ system. The followings are the points customers have to be careful of while designing in SATADOM-SV 3IE4 series with Pin8/Pin7 VCC.

When customers use SATADOM with Pin8/Pin7 VCC and the host SATA socket does not have power on Pin8/Pin7, external power must be provided to the SATADOM from the 3pin connector on the side. To have the advantages of SATADOM-SV 3IE4 series with Pin8/Pin7 VCC, and to avoid any potential damage on customer’s board designed with VCC power supply. Innodisk suggests that customers MUST design their board with a fuse which should be designed before the SATA socket Pin8/Pin7 VCC. In other words, customers are suggested NOT TO layout 5V VCC to SATA socket on board directly. A circuit diagram example to explain this is shown as below.

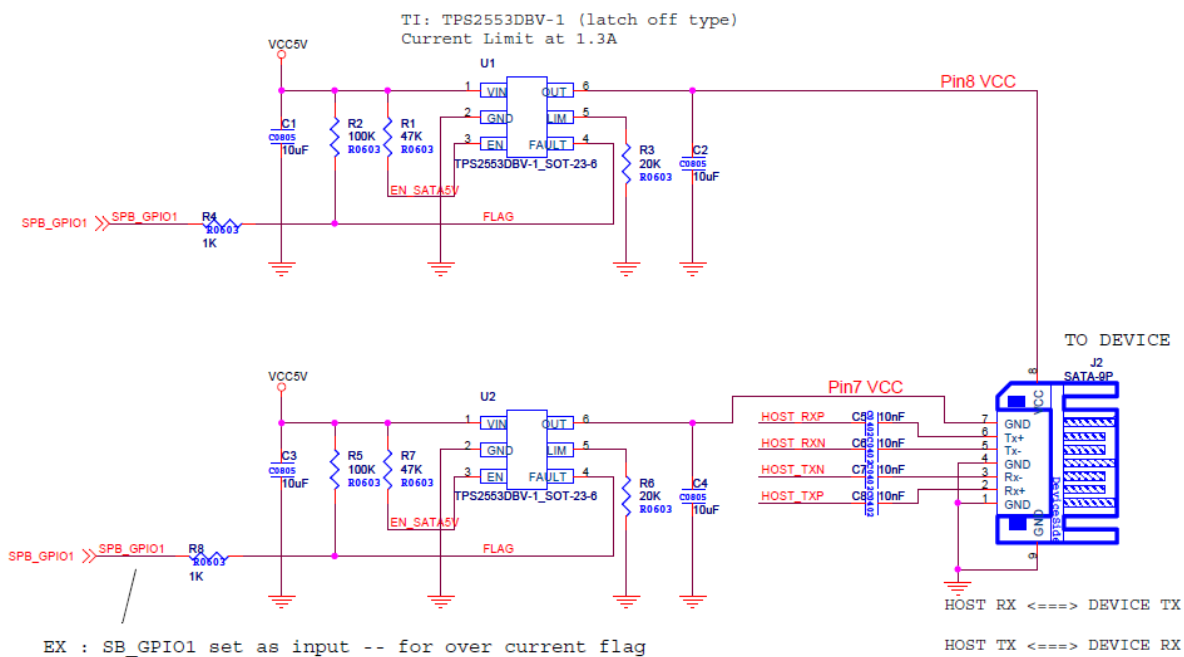

Figure 6: Pin 8 / Pin 7 host design in reference circuit

5. Part Number Rule

CODE	1	2	3	4	5	6	7	8	9	10	11	12	13	14	15	16	17	18	19	20	21	
	D	H	S	S	V	-	3	2	G	M	4	1	B	C	A	D	C	A	X	X	X	
Definition																						
Code 1st (Disk)											Code 14th (Operation Temperature)											
D: Disk											C: Standard Grade (0°C~ +70°C)											
Code 2nd (Feature set)											W: Industrial Grade (-40°C~ +85°C)											
H: iSLC series											Code 15th (Internal control)											
Code 3rd ~5th (Form factor)											1~0: TSOP PCB version											
SSV: SATADOM-SV											A~Z: BGA PCB version											
Code 7th ~9th (Capacity)											S: Single Channel											
08G:8GB			16G:16GB			32G:32GB			64G:64GB			D: Dual Channel										
Code 10th ~12th (Controller)											Code 17th (Flash Type)											
M41: 3IE4 Series											C: Toshiba MLC											
Code 13th (Flash mode)											Code 18th (Power supply config.)											
B: Synchronous flash for Toshiba 15nm											A: Pin8 version / Standard version											
											B: Pin8 & Pin7 version											
Code 19th~21st (Customize code)																						

6. Appendix

CE

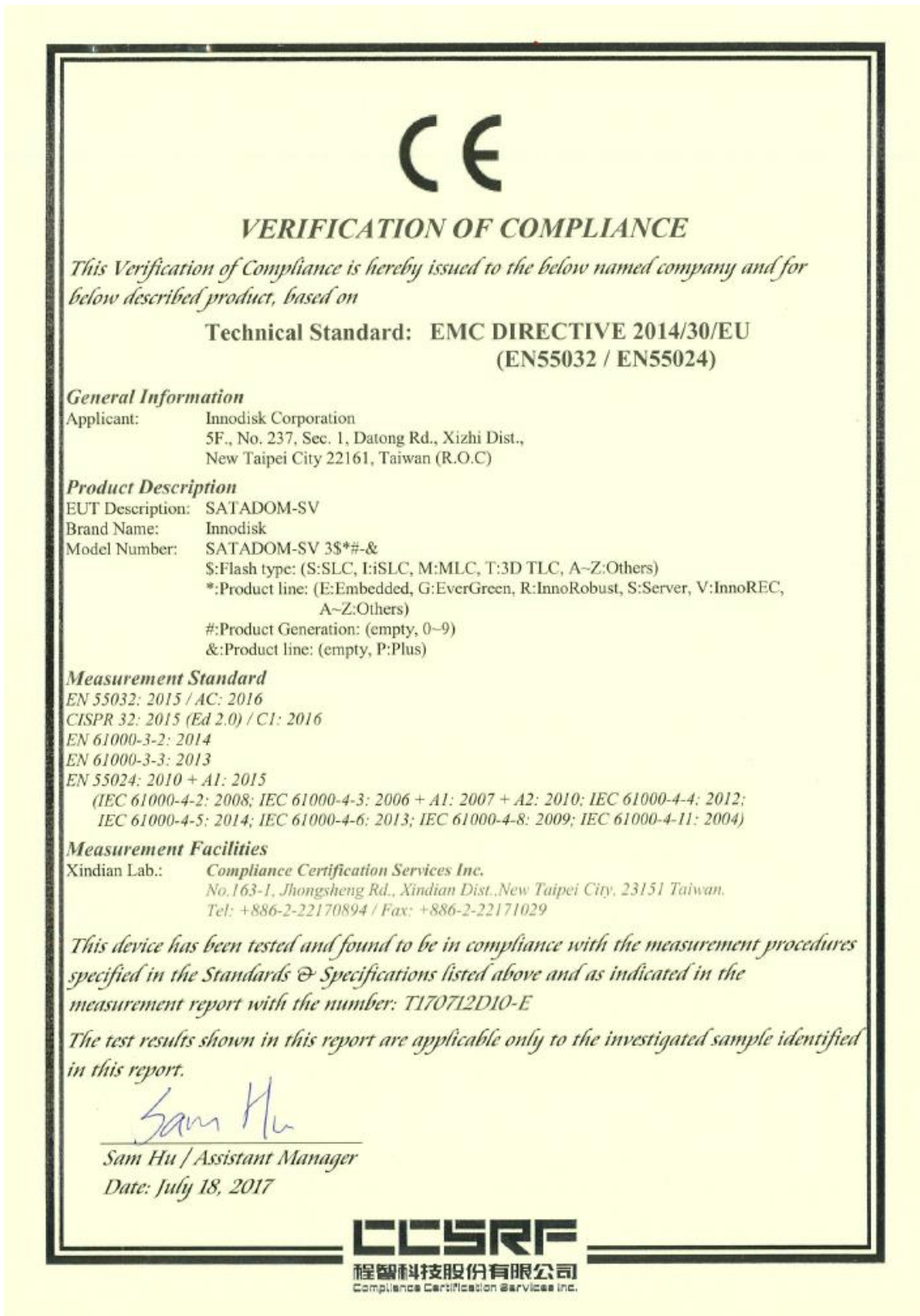

VERIFICATION OF COMPLIANCE

This Verification of Compliance is hereby issued to the below named company and for below described product, based on

**Technical Standard: FCC Part 15 Class B
IC ICES-003**

General Information

Applicant: Innodisk Corporation
5F., No. 237, Sec. 1, Datong Rd., Xizhi Dist.,
New Taipei City 22161, Taiwan (R.O.C)

Product Description

EUT Description: SATADOM-SV
Brand Name: Innodisk
Model Number: SATADOM-SV 3\$*#-&
S:Flash type: (S:SLC, I:iSLC, M:MLC, T:3D TLC, A~Z:Others)
*:Product line: (E:Embedded, G:EverGreen, R:InnoRobust, S:Server,
V:InnoREC, A~Z:Others)
#:Product Generation: (empty, 0~9)
&:Product line: (empty, P:Plus)

Measurement Facilities

Xindian Lab.: Compliance Certification Services Inc.
No.163-1, Jhongsheng Rd., Xindian Dist., New Taipei City, 23151 Taiwan.
Tel: +886-2-22170894 / Fax: +886-2-22171029

This device has been tested and found to be in compliance with the measurement procedures specified in the Standards & Specifications listed above and as indicated in the measurement report with the number: T170712D10-D

The test results shown in this report are applicable only to the investigated sample identified in this report.

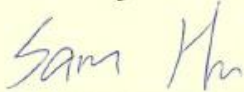

Sam Hu / Assistant Manager

Date: July 18, 2017

REACH

宜鼎國際股份有限公司
Innodisk Corporation
REACH Declaration

Tel:(02)7703-3000 Fax:(02) 7703-3555 Internet: <http://www.innodisk.com/>

We hereby confirm that the product(s) delivered to

Innodisk P/N	Description
All Innodisk EM FLASH Products	

- contain(s) **no** hazardous substances or constituents exceeding the defined threshold 0.1 % by weight in homogenous material if not otherwise specified, as described in the candidate list table currently including 201 substances and shown on the ECHA website (<http://echa.europa.eu/de/candidate-list-table>).
- contain(s) one or more hazardous substances or constituents exceeding 0.1 % by weight in homogenous material if not otherwise specified in candidate list table. Where the threshold value is exceeded, the substances in question are to be declared in accompanying Appendix A.
- Comply with REACH Annex XVII.

Guarantor

Company name 公司名稱：Innodisk Corporation 宜鼎國際股份有限公司

Company Representative 公司代表人：Randy Chien 簡川勝

Company Representative Title 公司代表人職稱：Chairman 董事長

Date 日期：2019 / 07 / 24



宜鼎國際股份有限公司
Innodisk Corporation

Page 1/2

Tel:(02)7703-3000 Fax:(02) 7703-3555 Internet: <http://www.innodisk.com/>

RoHS 自我宣告書 (RoHS Declaration of Conformity)

Manufacturer Product: All Innodisk EM Flash and Dram products

- 一、 宜鼎國際股份有限公司 (以下稱本公司) 特此保證售予貴公司之所有產品，皆符合歐盟 2011/65/EU 及 (EU) 2015/863 關於 RoHS 之規範要求。
Innodisk Corporation declares that all products sold to the company, are complied with European Union RoHS Directive (2011/65/EU) and (EU) 2015/863 requirement.
- 二、 本公司同意因本保證書或與本保證書相關事宜有所爭議時，雙方宜友好協商，達成協議。
Innodisk Corporation agrees that both parties shall settle any dispute arising from or in connection with this Declaration of Conformity by friendly negotiations.
- 三、 本公司聲明我們的產品符合 RoHS 指令的附件中 (7a)、(7c-1) 允許豁免。
We declare, our products permitted by the following exemptions specified in the Annex of the RoHS directive.
 - ※ (7a) Lead in high melting temperature type solders (i. e. lead-based alloys containing 85% by weight or more lead).
 - ※ (7C-1) Electrical and electronic components containing lead in a glass or ceramic other than dielectric ceramic in capacitors, e.g. piezoelectric devices, or in a glass or ceramic matrix compound.

Name of hazardous substance	Limited of RoHS ppm (mg/kg)
鉛 (Pb)	< 1000 ppm
汞 (Hg)	< 1000 ppm
鎘 (Cd)	< 100 ppm
六價鉻 (Cr 6+)	< 1000 ppm
多溴聯苯 (PBBs)	< 1000 ppm
多溴二苯醚 (PBDEs)	< 1000 ppm
鄰苯二甲酸二(2-乙基己基)酯 (DEHP)	< 1000 ppm
鄰苯二甲酸丁酯苯甲酯 (BBP)	< 1000 ppm
鄰苯二甲酸二丁酯 (DBP)	< 1000 ppm
鄰苯二甲酸二異丁酯 (DIBP)	< 1000 ppm

立 保 證 書 人 (Guarantor)

Company name 公司名稱: Innodisk Corporation 宜鼎國際股份有限公司

Company Representative 公司代表人: Randy Chien 簡川勝



宜鼎國際股份有限公司
Innodisk Corporation

Page 2/2

Company Representative Title 公司代表人職稱：Chairman 董事長

Date 日期：2018 / 07 / 01

