

Datasheet

# SATADOM-ML

## 3MS4 series

- SATA III solution for Server Boot-Up Drive
- Exclusive L<sup>3</sup> architecture
- DRAM-less, 100% data integrity
- Excellent random performance
- Designed with hardware LDPC ECC engine
- Cable-less through Pin 7/Pin 8 connectors
- Hardware write protection supported
- High less than 1U



## Introduction

Innodisk SATADOM-ML 3MS4 is characterized by L<sup>3</sup> architecture with the latest SATA III (6.0GHz) Marvell NAND controller. Innodisk's exclusive L<sup>3</sup> architecture is L<sup>2</sup> architecture multiplied LDPC (Low Density Parity Check). L<sup>2</sup> (Long Life) architecture is a 4K mapping algorithm that reduces WAF and features a real-time wear leveling algorithm to provide high performance and prolong lifespan with exceptional reliability.

Innodisk SATADOM-ML 3MS4 is designed for server field. The high of the SATADOM suit for 1U(44.5mm) high server, allowing it to fit seamlessly into any server setup. Besides, the main benefit is going to be the ability to use a SATA boot device without using a drive bay.

The innovative Pin8 uses the SATA connector itself as a power supply to drive the device without external cables. It could be connected directly to the SATA on-board socket on customer's system without additional power cable. Besides, the booting time for operation and the power consumption is less than hard disk drive (HDD), and can work under harsh environment compile with ATA protocol, no additional drives are required, and the SSD can be configured as a boot device or data storage device.

# SATADOM-ML

## 3MS4 series

Contact us for more information about the SATADOM-ML 3MS4.

Innodisk is a service-driven provider of industrial embedded flash storage and Dram products and technologies, with a focus on the cloud computing, industrial/embedded, and aerospace and defense industries.

### Diagram

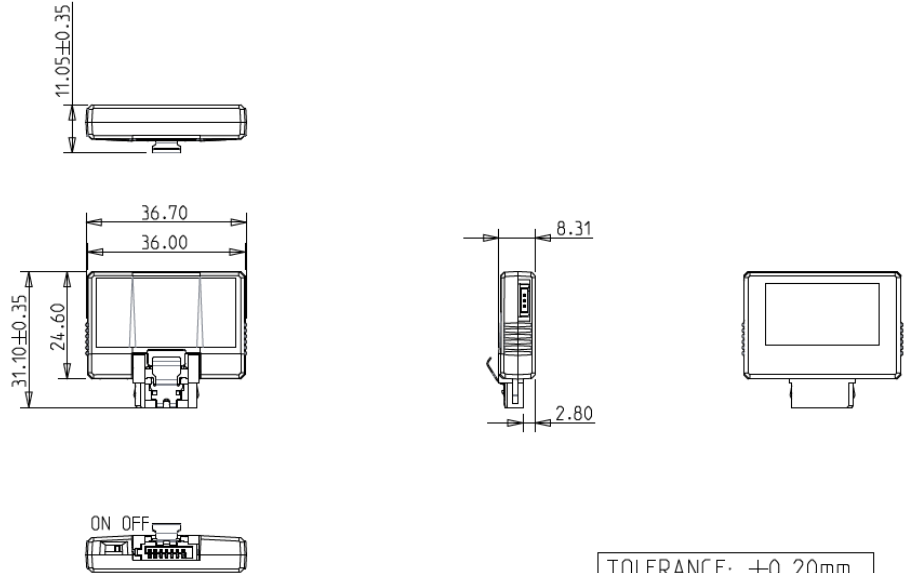

TOLERANCE:  $\pm 0.20\text{mm}$   
UNIT: mm

#### Headquarters (Taiwan)

5F., No. 237, Sec. 1, Datong Rd.,  
Xizhi Dist., New Taipei City,  
Taiwan (R.O.C.)  
Tel: +886-2-7703-3000  
Email: sales@innodisk.com

#### Branch Offices:

USA  
[usasales@innodisk.com](mailto:usasales@innodisk.com)  
+1-510-770-9421  
Europe  
[eusales@innodisk.com](mailto:eusales@innodisk.com)  
+31-40-3045-400  
Japan  
[jpsales@innodisk.com](mailto:jpsales@innodisk.com)  
+81-3-6667-0161  
China  
[sales\\_cn@innodisk.com](mailto:sales_cn@innodisk.com)  
+86-755-21673689  
[www.innodisk.com](http://www.innodisk.com)

© 2017 Innodisk Corporation.  
All right reserved. Specifications  
are subject to change without  
prior notice.

202404

### Specifications

Interface	SATA III
Flash Type	MLC
Capacity	32GB~256GB
Max. Channels	2
Sequential R/W (MB/sec, max.)	530/210
Max. Power Consumption	0.9W
Thermal Sensor	√
Extended DRAM buffer	-
H/W Write Protect	√
ATA Security	√
S.M.A.R.T.	√
Dimension (WxLxH)	36.7 x 31.2 x 10.7 mm
Environment	Vibration: 20G @7~2000Hz Shock: 1500G @ 0.5ms Storage Temperature: -55°C ~ +95°C MTBF: 3 million hours

### Ordering Information

	32GB	64GB	128GB	256GB
Standard Grade (0°C ~ +70°C)	DSSML-32GM41BCADC*	DSSML-64GM41BCADC*	DSSML-A28M41BCADC*	DSSML-B56M41BCADC*
Industrial Grade (-40°C ~ +85°C)	DSSML-32GM41BWADC*	DSSML-64GM41BWADC*	DSSML-A28M41BWADC*	DSSML-B56M41BWADC*

\*. A: Pin8+power cable / B: Pin8+Pin 7

**innodisk**

[www.innodisk.com](http://www.innodisk.com)