

# SATADOM-ML

## 3MS4 Series

**Customer:** \_\_\_\_\_  
**Customer**  
**Part Number:** \_\_\_\_\_  
**Innodisk**  
**Part Number:** \_\_\_\_\_  
**Innodisk**  
**Model Name:** \_\_\_\_\_  
**Date:** \_\_\_\_\_

<b>Innodisk Approver</b>	<b>Customer Approver</b>

**Total Solution For  
Industrial Flash Storage**

## Table of contents

<b>1. PRODUCT OVERVIEW .....</b>	<b>7</b>
<b>1.1 INTRODUCTION OF INNO DISK SATADOM-ML 3MS4 .....</b>	<b>7</b>
<b>1.2 PRODUCT VIEW AND MODELS .....</b>	<b>7</b>
<b>1.3 SATA INTERFACE .....</b>	<b>7</b>
<b>2. PRODUCT SPECIFICATIONS.....</b>	<b>8</b>
<b>2.1 CAPACITY AND DEVICE PARAMETERS.....</b>	<b>8</b>
<b>2.2 PERFORMANCE .....</b>	<b>8</b>
<b>2.3 ELECTRICAL SPECIFICATIONS .....</b>	<b>8</b>
<b>2.3.1 Power Requirement .....</b>	<b>8</b>
<b>2.3.2 Power Consumption.....</b>	<b>9</b>
<b>2.4 ENVIRONMENTAL SPECIFICATIONS .....</b>	<b>9</b>
<b>2.4.1 Temperature Ranges .....</b>	<b>9</b>
<b>2.4.2 Humidity .....</b>	<b>9</b>
<b>2.4.3 Shock and Vibration.....</b>	<b>9</b>
<b>2.4.4 Mean Time between Failures (MTBF).....</b>	<b>9</b>
<b>2.5 CE AND FCC COMPATIBILITY .....</b>	<b>10</b>
<b>2.6 RoHS COMPLIANCE .....</b>	<b>10</b>
<b>2.7 RELIABILITY.....</b>	<b>10</b>
<b>2.8 TRANSFER MODE .....</b>	<b>10</b>
<b>2.9 PIN ASSIGNMENT .....</b>	<b>11</b>
<b>2.10 MECHANICAL DIMENSIONS .....</b>	<b>11</b>
<b>2.11 ASSEMBLY WEIGHT .....</b>	<b>11</b>
<b>2.12 SEEK TIME .....</b>	<b>11</b>
<b>2.13 HOT PLUG.....</b>	<b>12</b>
<b>2.14 NAND FLASH MEMORY .....</b>	<b>12</b>
<b>3. THEORY OF OPERATION .....</b>	<b>13</b>
<b>3.1 OVERVIEW .....</b>	<b>13</b>
<b>3.2 SATA III CONTROLLER .....</b>	<b>13</b>
<b>3.3 ERROR DETECTION AND CORRECTION.....</b>	<b>13</b>
<b>3.4 WEAR-LEVELING .....</b>	<b>14</b>
<b>3.5 BAD BLOCKS MANAGEMENT.....</b>	<b>14</b>
<b>3.6 iDATA GUARD.....</b>	<b>14</b>
<b>3.7 GARBAGE COLLECTION .....</b>	<b>14</b>
<b>3.8 TRIM .....</b>	<b>14</b>
<b>4. INSTALLATION REQUIREMENTS .....</b>	<b>15</b>
<b>4.1 SATADOM-ML 3MS4 PIN DIRECTIONS.....</b>	<b>15</b>
<b>4.2 ELECTRICAL CONNECTIONS FOR SATADOM-ML 3MS4 .....</b>	<b>15</b>

<b>4.3 DEVICE DRIVE .....</b>	<b>15</b>
<b>4.4 POWER SUPPLY FOR SATDOM .....</b>	<b>15</b>
<b>4.4.1 Power cable .....</b>	<b>15</b>
<b>4.4.2 Pin8 and Pin7 VCC .....</b>	<b>16</b>
<b>4.5 WRITE PROTECTION .....</b>	<b>17</b>
<b>5. PART NUMBER RULE .....</b>	<b>18</b>
<b>6. APPENDIX .....</b>	<b>19</b>

## REVISION HISTORY

Revision	Description	Date
V1.0	First Released	Apr., 2017
V1.1	Update Product Photo & Mechanical Drawing	Apr., 2024

## List of Tables

<b>TABLE 1: DEVICE PARAMETERS</b> .....	8
<b>TABLE 2: PERFORMANCE</b> .....	8
<b>TABLE 3: INNODISK SATADOM-ML 3MS4 POWER REQUIREMENT</b> .....	8
<b>TABLE 4: POWER CONSUMPTION</b> .....	9
<b>TABLE 5: TEMPERATURE RANGE FOR SATADOM-ML 3MS4</b> .....	9
<b>TABLE 6: SHOCK/VIBRATION TESTING FOR SATADOM-ML 3MS4</b> .....	9
<b>TABLE 7: SATADOM-ML 3MS4 MTBF</b> .....	10
<b>TABLE 8: SATADOM-ML 3MS4 TBW</b> .....	10
<b>TABLE 9: INNODISK SATADOM-ML 3MS4 PIN ASSIGNMENT</b> .....	11

## List of Figures

<b>FIGURE 1: INNODISK SATADOM-ML 3MS4</b> .....	7
<b>FIGURE 2: INNODISK SATADOM-ML 3MS4 MECHANICAL DIAGRAM</b> .....	11
<b>FIGURE 3: INNODISK SATADOM-ML 3MS4 BLOCK DIAGRAM</b> .....	13
<b>FIGURE 4: SIGNAL SEGMENT AND POWER SEGMENT</b> .....	15
<b>FIGURE 5: STANDARD POWER CABLE</b> .....	15
<b>FIGURE 6: PIN 8 / PIN 7 HOST DESIGN IN REFERENCE CIRCUIT</b> .....	16
<b>FIGURE 7: HARDWARE WRITE PROTECT POSITION</b> .....	17

# 1. Product Overview

## 1.1 Introduction of Innodisk SATADOM-ML 3MS4

Innodisk SATADOM-ML 3MS4 is characterized by L3 architecture with the latest SATA III (6.0GHz) Marvell NAND controller. Innodisk’s exclusive L3 architecture is L2 architecture multiplied LDPC (Low Density Parity Check). L2 (Long Life) architecture is a 4K mapping algorithm that reduces WAF and features a real-time wear leveling algorithm to provide high performance and prolong lifespan with exceptional reliability.

Innodisk SATADOM-ML 3MS4 is designed for server field. The high of the SATADOM suit for 1U(44.5mm) high server, allowing it to fit seamlessly into any server setup. Besides, the main benefit is going to be the ability to use a SATA boot device without using a drive bay.

## 1.2 Product View and Models

Innodisk SATADOM-ML 3MS4 is available in follow capacities within MLC flash ICs.

[SATADOM-ML 3MS4 32GB](#)

[SATADOM-ML 3MS4 64GB](#)

[SATADOM-ML 3MS4 128GB](#)

[SATADOM-ML 3MS4 256GB](#)



**Figure 1: Innodisk SATADOM-ML 3MS4**

## 1.3 SATA Interface

Innodisk SATADOM-ML 3MS4 supports SATA III interface, and compliant with SATA I and SATA II.

## 2. Product Specifications

### 2.1 Capacity and Device Parameters

SATADOM-ML 3MS4 device parameters are shown in Table 1.

**Table 1: Device parameters**

Capacity	Cylinders	Heads	Sectors	LBA	User Capacity(MB)
32GB	16383	16	63	62533296	30533
64GB	16383	16	63	125045424	61057
128GB	16383	16	63	250069680	122104
256GB	16383	16	63	500118192	244198

### 2.2 Performance

Burst Transfer Rate: 6.0Gbps

**Table 2: Performance**

Capacity	32GB	64GB	128GB	256GB
Sequential* Read (max.)	450 MB/s	530 MB/s	530 MB/s	530 MB/s
Sequential* Write (max.)	50 MB/s	100 MB/s	180 MB/s	210 MB/s
4KB Random** Read (QD32)	19,500 IOPS	27,800 IOPS	32,000 IOPS	32,000 IOPS
4KB Random** Write (QD32)	12,800 IOPS	25,100 IOPS	30,700 IOPS	30,700 IOPS

Note: \* Sequential performance is based on CrystalDiskMark 5.1.2 with file size 1000MB

\*\* Random performance is based on IO meter with Queue Depth 32

### 2.3 Electrical Specifications

#### 2.3.1 Power Requirement

**Table 3: Innodisk SATADOM-ML 3MS4 Power Requirement**

Item	Symbol	Rating	Unit
Input voltage	V <sub>IN</sub>	+5 DC +- 5%	V



### 2.3.2 Power Consumption

**Table 4: Power Consumption**

Mode	Power Consumption (mA)
Read	100mA (max.)
Write	171mA (max.)
Idle	82mA (max.)
Pin 7/ Pin8 VCC Initial*	1000(max.)

Target: 128GB SATADOM-ML 3MS4

**\*To design in Pin7/8 VCC on motherboard, 5V with 1A power supply is requested.**

## 2.4 Environmental Specifications

### 2.4.1 Temperature Ranges

**Table 5: Temperature range for SATADOM-ML 3MS4**

Temperature	Range
Operating	Standard Grade: 0°C to +70°C
	Industrial Grade: -40°C to +85°C
Storage	-55°C to +95°C

### 2.4.2 Humidity

Relative Humidity: 10-95%, non-condensing

### 2.4.3 Shock and Vibration

**Table 6: Shock/Vibration Testing for SATADOM-ML 3MS4**

Reliability	Test Conditions	Reference Standards
Vibration	7 Hz to 2K Hz, 20G, 3 axes	IEC 68-2-6
Mechanical Shock	Duration: 0.5ms, 1500 G, 3 axes	IEC 68-2-27

### 2.4.4 Mean Time between Failures (MTBF)

Table 7 summarizes the MTBF prediction results for various SATADOM-ML 3MS4 configurations. The analysis was performed using a RAM Commander™ failure rate prediction.

- **Failure Rate:** The total number of failures within an item population, divided by the total number of life units expended by that population, during a particular measurement interval under stated condition.
- **Mean Time between Failures (MTBF):** A basic measure of reliability for repairable items: The mean number of life units during which all parts of the item perform within their specified limits, during a particular measurement interval under stated conditions.

**Table 7: SATADOM-ML 3MS4 MTBF**

Product	Condition	MTBF (Hours)
Innodisk SATADOM-ML 3MS4	Telcordia SR-332 GB, 25°C	>3,000,000

## 2.5 CE and FCC Compatibility

SATADOM-ML 3MS4 conforms to CE and FCC requirements.

## 2.6 RoHS Compliance

SATADOM-ML 3MS4 is fully compliant with RoHS directive.

## 2.7 Reliability

**Table 8: SATADOM-ML 3MS4 TBW**

Parameter		Value
Read Cycles		Unlimited Read Cycles
Flash endurance		3,000 P/E cycles
Wear-Leveling Algorithm		Support
Bad Blocks Management		Support
Error Correct Code		Support
<b>TBW* (Total Bytes Written) Unit: TB</b>		
Capacity	Sequential workload	Client workload
32GB	93.6	62.4
64GB	187.2	124.8
128GB	374.4	208.3
256GB	748.8	416.6
* Note:		
<ol style="list-style-type: none"> <li>1. Sequential: Mainly sequential write, tested by Vdbench.</li> <li>2. Client: Follow JESD218 Test method and JESD219A Workload, tested by ULINK. (The capacity lower than 64GB client workload is not specified in JEDEC219A, the values are estimated.)</li> <li>3. Based on out-of-box performance.</li> </ol>		

## 2.8 Transfer Mode

SATADOM-ML 3MS4 support following transfer mode:

Serial ATA I 1.5Gbps

Serial ATA II 3.0Gbps

Serial ATA III 6.0Gbps

## 2.9 Pin Assignment

Innodisk SATADOM-ML 3MS4 uses a standard SATA pin-out. See Table 9 for SATADOM-ML 3MS4 pin assignment.

**Table 9: Innodisk SATADOM-ML 3MS4 Pin Assignment**

Name	Type	Description
Pin 0	GND	Shielding
Pin 1	GND	Shielding
Pin 2	A+	Differential signal to A
Pin 3	A-	Differential signal to A-
Pin 4	GND	Shielding
Pin 5	B-	Differential signal to B-
Pin 6	B+	Differential signal to B
Pin 7	GND/ Vcc*	Shielding/ +5V Power*
Pin 8	VCC	+5V Power

\* SATADOM-ML 3MS4 default power supply through pin 8 or extra power cable.

Pin 7 power supply as an optional function with separated PN end of B.

## 2.10 Mechanical Dimensions

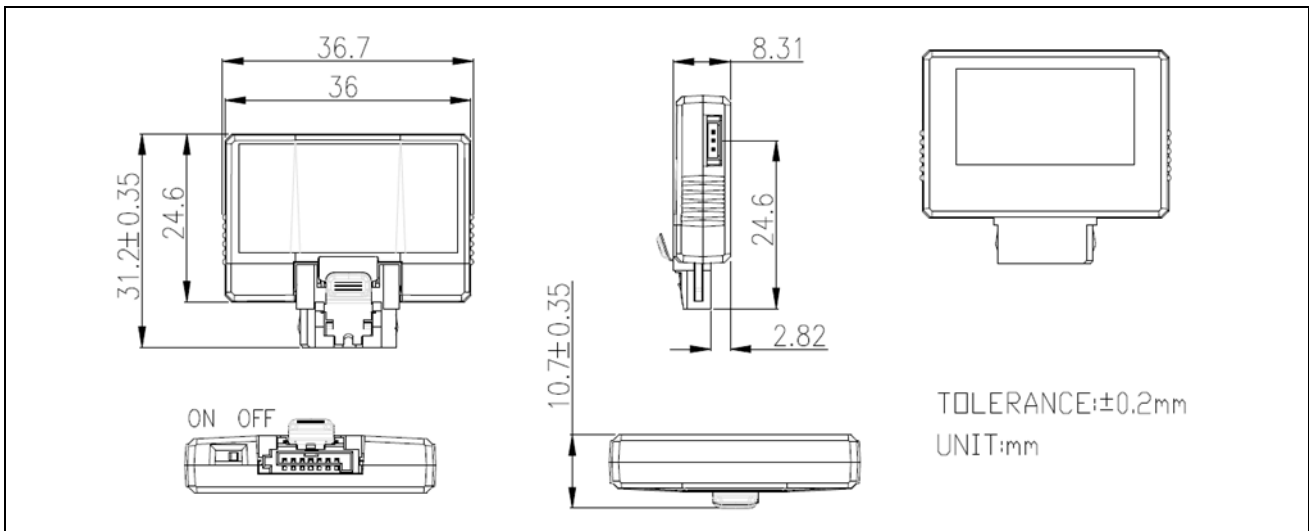

**Figure 2: Innodisk SATADOM-ML 3MS4 mechanical diagram**

## 2.11 Assembly Weight

An Innodisk SATADOM-ML 3MS4 within flash ICs, 32GB's weight is 7 grams approximately.

## 2.12 Seek Time

Innodisk SATADOM-ML 3MS4 is not a magnetic rotating design. There is no seek or rotational latency required.

## 2.13 Hot Plug

The SSD support hot plug function and can be removed or plugged-in during operation. User has to avoid hot plugging the SSD which is configured as boot device and installed operation system.

**Surprise hot plug** : The insertion of a SATA device into a backplane (combine signal and power) that has power present. The device powers up and initiates an OOB sequence.

**Surprise hot removal**: The removal of a SATA device from a powered backplane, without first being placed in a quiescent state.

## 2.14 NAND Flash Memory

Innodisk SATADOM-ML 3MS4 uses Multi Level Cell (MLC) NAND flash memory, which is non-volatility, high reliability and high speed memory storage. Each cell stores 2 bits or holds four states per cell. Read or Write data to flash memory for SSD is control by microprocessor.

# 3. Theory of Operation

## 3.1 Overview

Figure 3 shows the operation of Innodisk SATADOM-ML 3MS4 from the system level, including the major hardware blocks.

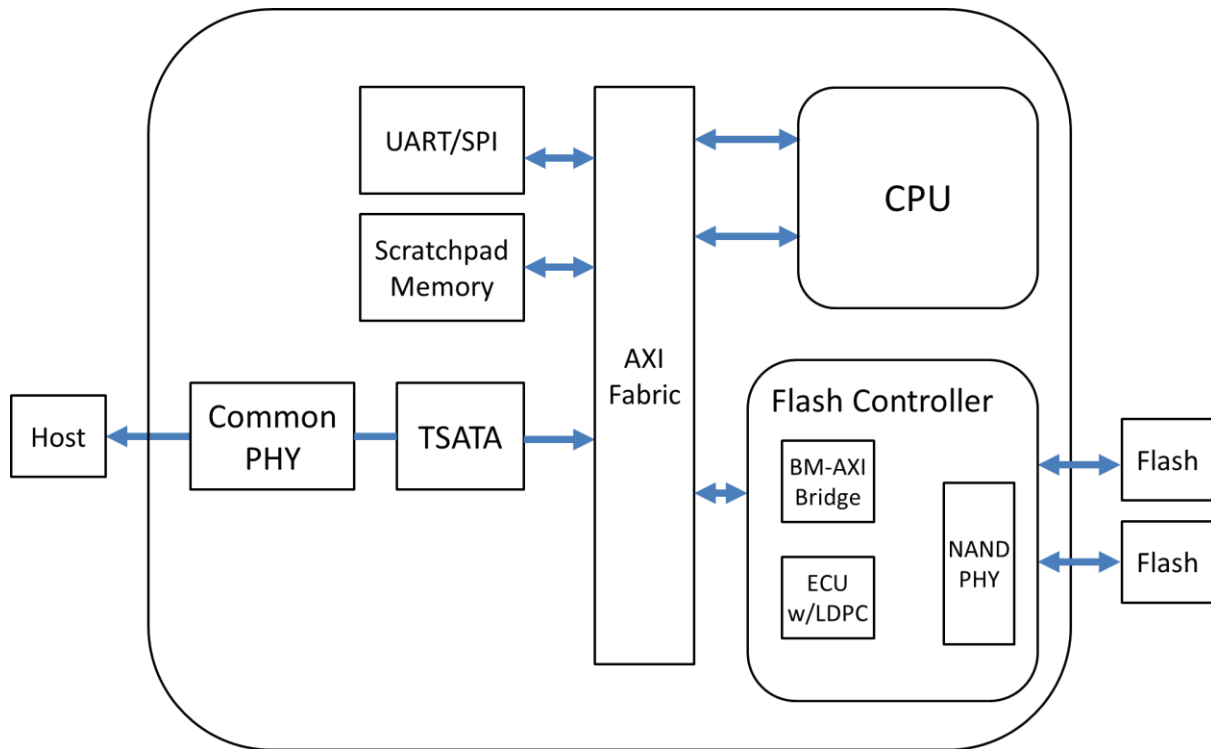

**Figure 3: Innodisk SATADOM-ML 3MS4 Block Diagram**

Innodisk SATADOM-ML 3MS4 integrates a SATA III controller and NAND flash memories. Communication with the host occurs through the host interface, using the standard ATA protocol. Communication with the flash device(s) occurs through the flash interface.

## 3.2 SATA III Controller

Innodisk SATADOM-ML 3MS4 is designed with 88NV1120, a SATA III 6.0Gbps (Gen. 3) controller. The Serial ATA physical, link and transport layers are compliant with Serial ATA Gen 1, Gen 2 and Gen 3 specification (Gen 3 supports 1.5Gbps/3.0Gbps/6.0Gbps data rate). The controller has 2 channels for flash interface.

## 3.3 Error Detection and Correction

Innodisk SATADOM-ML 3MS4 is designed with hardware LDPC ECC engine with hard-decision and soft-decision decoding. Low-density parity-check (LDPC) codes have excellent error correcting performance close to the Shannon limit when decoded with the belief-propagation (BP) algorithm using soft-decision information.

### 3.4 Wear-Leveling

Flash memory can be erased within a limited number of times. This number is called the **erase cycle limit** or **write endurance limit** and is defined by the flash array vendor. The erase cycle limit applies to each individual erase block in the flash device.

Innodisk SATADOM-ML 3MS4 uses a static wear-leveling algorithm to ensure that consecutive writes of a specific sector are not written physically to the same page/block in the flash. This spreads flash media usage evenly across all pages, thereby extending flash lifetime.

### 3.5 Bad Blocks Management

Bad Blocks are blocks that contain one or more invalid bits whose reliability are not guaranteed. The Bad Blocks may be presented while the SSD is shipped, or may develop during the life time of the SSD. When the Bad Blocks is detected, it will be flagged, and not be used anymore. The SSD implement Bad Blocks management, Bad Blocks replacement, Error Correct Code to avoid data error occurred. The functions will be enabled automatically to transfer data from Bad Blocks to spare blocks, and correct error bit.

### 3.6 iData Guard

Innodisk's power cycling management is a comprehensive data protection mechanism that functions before and after a sudden power outage to SSD. Low-power detection terminates data writing before an abnormal power-off, while table-remapping after power-on deletes corrupt data and maintains data integrity. Innodisk's power cycling provides effective power cycling management, preventing data stored in flash from degrading with use.

### 3.7 Garbage Collection

Garbage collection is used to maintain data consistency and perform continual data cleansing on SSDs. It runs as a background process, freeing up valuable controller resources while sorting good data into available blocks, and deleting bad blocks. It also significantly reduces write operations to the drive, thereby increasing the SSD's speed and lifespan.

### 3.8 TRIM

The TRIM command is designed to enable the operating system to notify the SSD which pages no longer contain valid data due to erases either by the user or operating system itself. During a delete operation, the OS will mark the sectors as free for new data and send a TRIM command to the SSD to mark them as not containing valid data. After that the SSD knows not to preserve the contents of the block when writing a page, resulting in less write amplification with fewer writes to the flash, higher write speed, and increased drive life.

# 4. Installation Requirements

## 4.1 SATADOM-ML 3MS4 Pin Directions

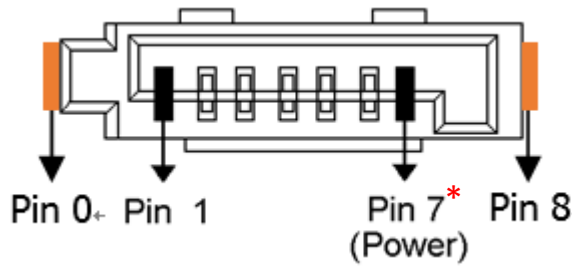

Figure 4: Signal Segment and Power Segment

\* SATADOM-ML 3MS4 default power supply through pin 8 or extra power cable.

Pin 7 power supply as an optional function with separate PN end of B.

## 4.2 Electrical Connections for SATADOM-ML 3MS4

A Serial ATA device may be either directly connected to a host or connected to a host through a cable. For connection via cable, the cable should be no longer than 1 meter. The SATA interface has a separate connector for the power supply. Please refer to the pin description for further details.

## 4.3 Device Drive

No additional device drives are required. The Innodisk SATADOM-ML 3MS4 can be configured as a boot device.

## 4.4 Power supply for SATDOM

### 4.4.1 Power cable

A power cable is shipped with each SATADOM product, which has standard 4 pins power connector and special 3 pins power connector for SATADOM. The male and female power connector of SATADOM have foolproof design to avoid misconnection, please check it before power on. Innodisk also can customize the power connector for different host power socket design.

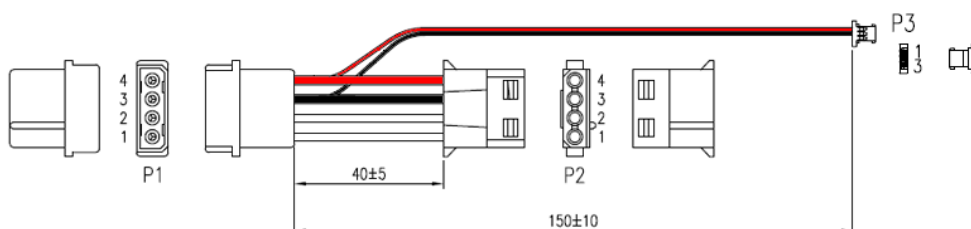

Figure 5: Standard power cable

### 4.4.2 Pin8 and Pin7 VCC

Innodisk’s SATADOM SSDs provide an elegant, compact option for SSD storage in embedded systems, industrial PCs and server motherboards with their small form factor that connects directly to the SATA connector on the motherboard. This simplified SSD design not only frees up a precious drive bay for other storage options but eliminates messy, obtrusive SATA data cabling. Innodisk’s patented Pin7 and Pin 8 SATA Power technologies take the cable-less concept to the next step by also eliminating the need for power cables for a 100% cable-less, shock resistant, space saving plug-and-play storage solution that optimizes airflow and makes the best use of limited board space in embedded and rackmount server systems.

SATADOM-ML 3MS4 series with Pin8/Pin7 VCC, it is defined Pin8/Pin7 as VCC on the SATA connector. Thus the power would come from SATA connector Pin8/Pin7 VCC. Customers DO NOT have to use the power cable for power supply. Such a cable-less design of SATADOM-ML 3MS4 series with Pin8/Pin7 VCC brings more convenience to customers’ system. The followings are the points customers have to be careful of while designing in SATADOM-ML 3MS4 series with Pin8/Pin7 VCC.

When customers use SATADOM with Pin8/Pin7 VCC and the host SATA socket does not have power on Pin8/Pin7, external power must be provided to the SATADOM from the 3pin connector on the side. To have the advantages of SATADOM-ML 3MS4 series with Pin8/Pin7 VCC, and to avoid any potential damage on customer’s board designed with VCC power supply. Innodisk suggests that customers MUST design their board with a fuse which should be designed before the SATA socket Pin8/Pin7 VCC. In other words, customers are suggested NOT TO layout 5V VCC to SATA socket on board directly. A circuit diagram example to explain this is shown as below.

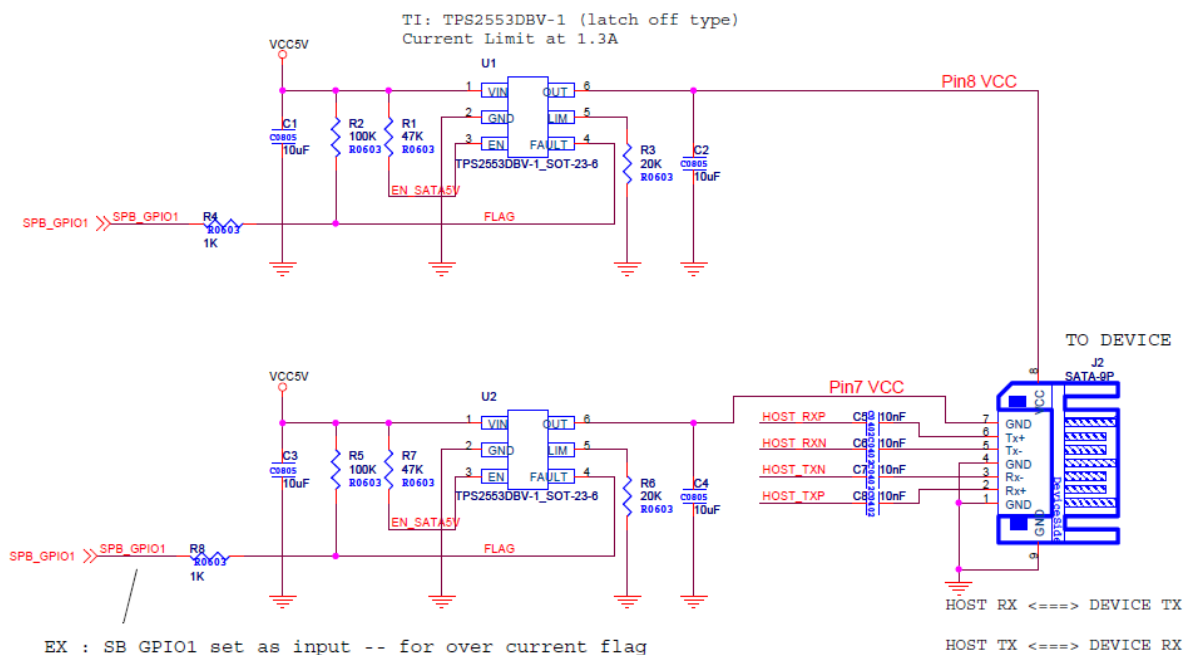
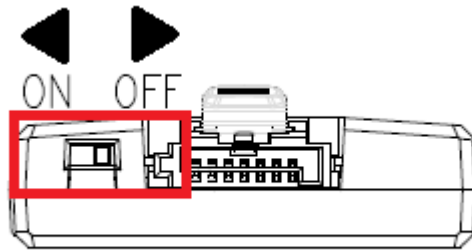

**Figure 6: Pin 8 / Pin 7 host design in reference circuit**



### 4.5 Write Protection

SATADOM-ML 3MS4 within the hardware write-protect function could prevent the device from modification and deletion. Write-protected data could only be read, that is, users could not write to it, edit it, append data to it, or delete it. When users would like to make sure that neither themselves nor others could modify or destroy the file, users could switch on write-protection. Thus, SATADOM-ML 3MS4 could process write-protect mechanism and disable flash memory to be written-in any data. Only while the system power-off, users could switch on write-protection. Write-protection could not be switched-on, after OS booting.



**Figure 7: Hardware write protect position**

## 5. Part Number Rule

CODE	1	2	3	4	5	6	7	8	9	10	11	12	13	14	15	16	17	18	19	20	21	
	<b>D</b>	<b>S</b>	<b>S</b>	<b>M</b>	<b>L</b>	<b>-</b>	<b>3</b>	<b>2</b>	<b>G</b>	<b>M</b>	<b>4</b>	<b>1</b>	<b>B</b>	<b>C</b>	<b>A</b>	<b>D</b>	<b>C</b>	<b>A</b>	<b>X</b>	<b>X</b>	<b>X</b>	
<b>Definition</b>																						
<b>Code 1<sup>st</sup> (Disk)</b>											<b>Code 14<sup>th</sup> (Operation Temperature)</b>											
D: Disk											C: Standard Grade (0°C ~ +70°C)											
<b>Code 2<sup>nd</sup> (Feature set)</b>											W: Industrial Grade (-40°C ~ +85°C)											
S: Server series											<b>Code 15<sup>th</sup> (Internal control)</b>											
<b>Code 3<sup>rd</sup> ~5<sup>th</sup> (Form factor)</b>											A~Z: BGA PCB version											
SML: SATADOM-ML											<b>Code 16<sup>th</sup> (Channel of data transfer)</b>											
<b>Code 7<sup>th</sup> ~9<sup>th</sup> (Capacity)</b>											D: Dual Channel											
32G:32GB			64G:64GB			A28:128GB			B56:256GB													
<b>Code 10<sup>th</sup> ~12<sup>th</sup> (Controller)</b>											<b>Code 17<sup>th</sup> (Flash Type)</b>											
M41: 3MS4 Series											C: Toshiba MLC											
											<b>Code 18<sup>th</sup> (Power supply config.)</b>											
<b>Code 13<sup>th</sup> (Flash mode)</b>											A: Pin8 version / Standard version											
B: Synchronous flash for Toshiba 15nm											B: Pin8 & Pin7 version											
											<b>Code 19<sup>th</sup>~21<sup>st</sup> (Customize code)</b>											

## 6. Appendix

CE

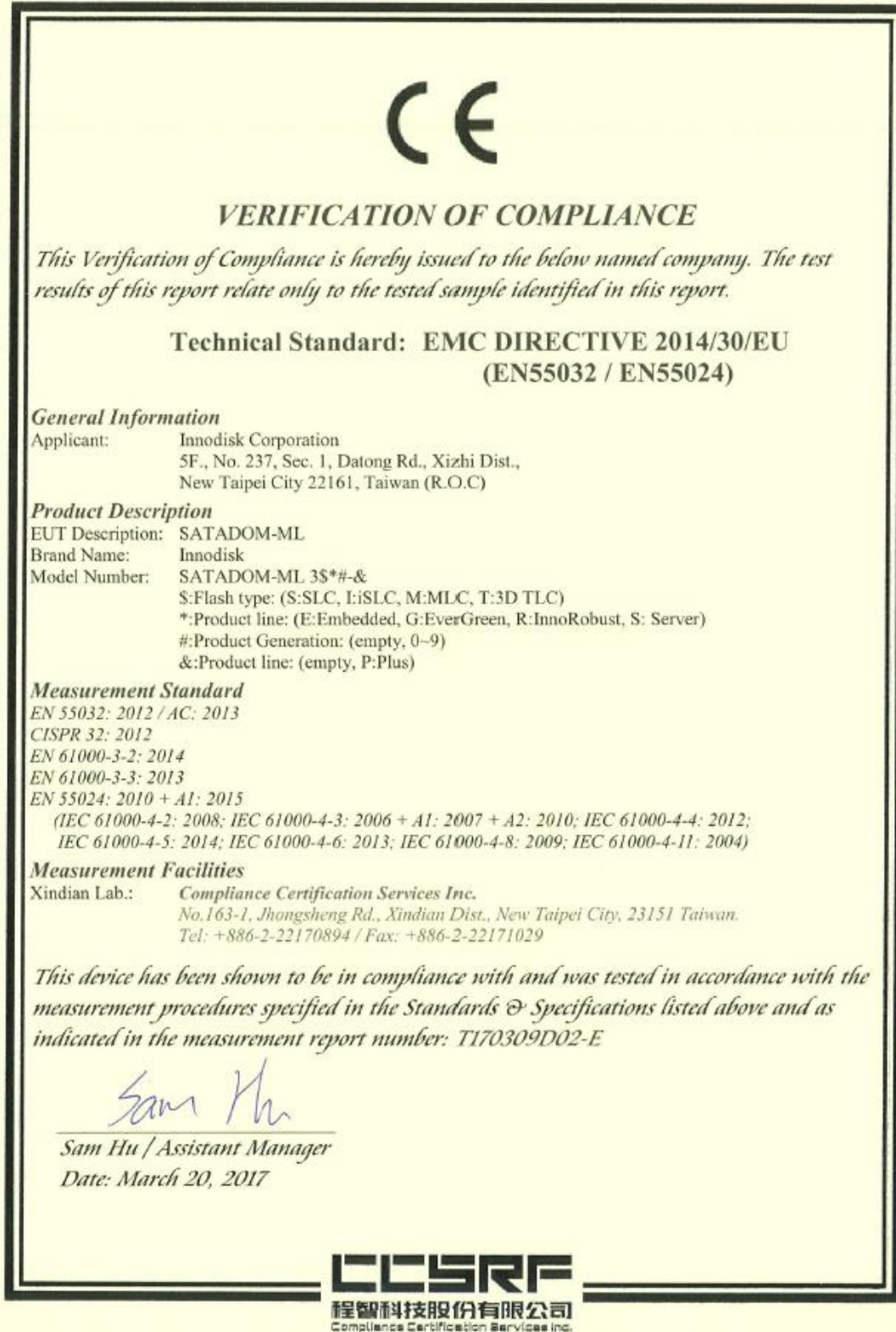

FCC



### VERIFICATION OF COMPLIANCE

*This Verification of Compliance is hereby issued to the below named company. The test results of this report relate only to the tested sample identified in this report.*

**Technical Standard: FCC Part 15 Class B  
IC ICES-003**

#### General Information

Applicant: Innodisk Corporation  
5F., No. 237, Sec. 1, Datong Rd., Xizhi Dist.,  
New Taipei City 22161, Taiwan (R.O.C)

#### Product Description

EUT Description: SATADOM-ML  
Brand Name: Innodisk  
Model Number: SATADOM-ML 3\$\*#-&  
\$:Flash type: (S:SLC, I:iSLC, M:MLC, T:3D TLC)  
\*:Product line: (E:Embedded, G:EverGreen, R:InnoRobust, S: Server)  
#:Product Generation: (empty, 0~9)  
&:Product line: (empty, P:Plus)

#### Measurement Facilities

Xindian Lab.: Compliance Certification Services Inc.  
No.163-1, Jhongsheng Rd., Xindian Dist., New Taipei City, 23151 Taiwan.  
Tel: +886-2-22170894 / Fax: +886-2-22171029

*This device has been shown to be in compliance with and was tested in accordance with the measurement procedures specified in the Standards & Specifications listed above and as indicated in the measurement report number: T170309D02-D*

Sam Hu / Assistant Manager

Date: March 20, 2017

**CCSRF**  
程智科技股份有限公司  
Compliance Certification Services Inc.



# WHQL Compliance Test Compliance

TM

## Program

# Test Report

Company Name: Innodisk Corporation

Model Name: SATADOM-ML 3MS4

WHQL Category: Storage

Test Start Date: 2017/3/13

Report Date: 2017/3/16

Overall Test Result: Pass

Family Model: SATADOM-xx 3MS4  
SATADOM-xx 3ME4  
xx : Family type include (SV, SH, SL, MV, MH, ML)

Project ID : SSD-IC-WHQL-001-1(\*)

## REACH

innodisk

宜鼎國際股份有限公司  
Innodisk Corporation

Tel: (02) 7703-3000 Fax: (02) 7703-3555 Internet: <http://www.innodisk.com/>

## REACH Declaration of Conformity

### Manufacturer Product: All Innodisk EM Flash and Dram products

1. 宜鼎國際股份有限公司（以下稱本公司）特此保證此售予貴公司之產品，皆符合歐盟化學品法案(Registration, Evaluation and Authorization of Chemicals; REACH)之規定 (<http://www.echa.europa.eu/de/candidate-list-table> last updated: 20/06/2016)。所提供之產品包含：(1) 產品或產品所使用到的所有原物料；(2) 包裝材料；(3) 設計、生產及重工過程中所使用到的所有原物料。

We Innodisk Corporation hereby declare that our products are in compliance with the requirements according to the REACH Regulation

(<http://www.echa.europa.eu/de/candidate-list-table> last updated: 20/06/2016).

Products include: 1) Product and raw material used by the product; 2) Packaging material; 3) Raw material used in the process of design, production and rework

2. 本公司同意因本保證書或與本保證書相關事宜有所爭議時，雙方宜友好協商，達成協議。

InnoDisk Corporation agrees that both parties shall settle any dispute arising from or in connection with this Declaration of Conformity by friendly negotiations.

### 立 保 證 書 人 (Guarantor)

Company name 公司名稱：InnoDisk Corporation 宜鼎國際股份有限公司

Company Representative 公司代表人：Randy Chien 簡川勝

Company Representative Title 公司代表人職稱：Chairman 董事長

Date 日期：2016 / 06 / 23





**宜鼎國際股份有限公司  
Innodisk Corporation**

Tel:(02)7703-3000 Fax:(02) 7703-3555 Internet: <http://www.innodisk.com/>

**RoHS 自我宣告書 (RoHS Declaration of Conformity)**

**Manufacturer Product: All Innodisk EM Flash and Dram products**

一、 宜鼎國際股份有限公司 (以下稱本公司) 特此保證售予新漢股份有限公司之所有產品, 皆符合歐盟 2011/65/EU 關於 RoHS 之規範要求。

Innodisk Corporation declares that all products sold to Nexcom, are complied with European Union RoHS Directive (2011/65/EU) requirement.

二、 本公司同意因本保證書或與本保證書相關事宜有所爭議時, 雙方宜友好協商, 達成協議。

Innodisk Corporation agrees that both parties shall settle any dispute arising from or in connection with this Declaration of Conformity by friendly negotiations.

Name of hazardous substance	Limited of RoHS ppm (mg/kg)
鉛 (Pb)	< 1000 ppm
汞 (Hg)	< 1000 ppm
鎘 (Cd)	< 100 ppm
六價鉻 (Cr 6+)	< 1000 ppm
多溴聯苯 (PBBs)	< 1000 ppm
多溴二苯醚 (PBDEs)	< 1000 ppm

**立保證書人 (Guarantor)**

Company name 公司名稱: Innodisk Corporation 宜鼎國際股份有限公司

Company Representative 公司代表人: Randy Chien 簡川勝

Company Representative Title 公司代表人職稱: Chairman 董事長

Date 日期: 2016 / 08 / 04

