

Datasheet

SATADOM-ML

3SE3 series

- Best boot drive solution for server and embedded system
- SATA III interface
- High IOPS to reduce boot up timing
- Built-in Pin 8 power supply
- Intelligent error recovery system
- Zero mechanical interference
- Anti-vibration mechanical design
- iSMART disk health monitoring



Introduction

Innodisk Serial ATA Disk on Module (SATADOM) supports SATA III standard (6.0Gb/s) interface with excellent performance, and SATADOM-ML 3SE3 is designed as the smallest form factor size that could enhance compatibility with various design applications.

Innodisk's patented Pin7 and Pin 8 SATA power supply technologies use the SATA connector itself as a power supply to drive the device without external power cables. It is a 100% cable-less, shock resistant, space saving and plug-and-play storage solution that optimizes airflow and makes the best use of limited board space in embedded and rackmount server systems.

Innodisk SATADOM-ML 3SE3 effectively reduces the booting time of operation system and the power consumption is less than hard disk drive (HDD), and complies with ATA protocol, no additional drives are required, and can be configured as a boot device or data storage device.

SATADOM-ML

3SE3 series

Contact us for more information about the SATADOM-ML 3SE3.

Innodisk is a service-driven provider of industrial embedded flash storage and Dram products and technologies, with a focus on the cloud computing, industrial/embedded, and aerospace and defense industries.

Diagram

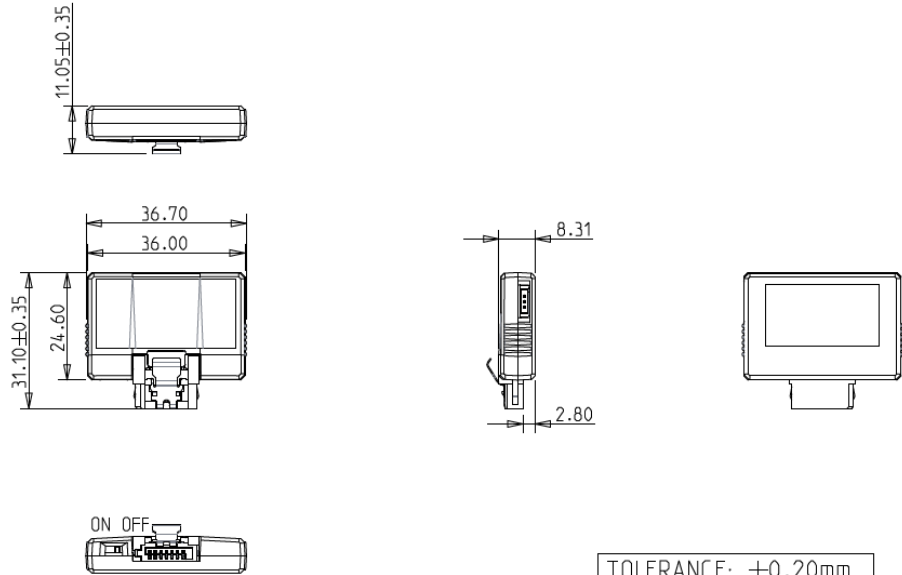

TOLERANCE: $\pm 0.20\text{mm}$
UNIT: mm

Headquarters (Taiwan)

5F., No. 237, Sec. 1, Datong Rd.,
Xizhi Dist., New Taipei City,
Taiwan (R.O.C.)
Tel: +886-2-7703-3000
Email: sales@innodisk.com

Branch Offices:

USA
usasales@innodisk.com
+1-510-770-9421
Europe
esusales@innodisk.com
+31-40-3045-400
Japan
jpsales@innodisk.com
+81-3-6667-0161
China
sales_cn@innodisk.com
+86-755-21673689
www.innodisk.com

© 2017 Innodisk Corporation.
All right reserved. Specifications
are subject to change without
prior notice.

202404

Specifications

Interface	SATA III
Flash Type	SLC
Capacity	4GB~64GB
Max. Channels	4
Sequential R/W (MB/sec, max.)	400/200
Max. Power Consumption	1.1W
Thermal Sensor	ST- Optional/ WT- Default
Extended DRAM buffer	-
H/W Write Protect	✓
ATA Security	✓
S.M.A.R.T.	✓
Dimension (WxLxH)	36.7 X 31.2 X 10.7 mm
Environment	Vibration: 20G @7~2000Hz Shock: 1500G @ 0.5ms Storage Temperature: -55°C ~ +95°C MTBF: 3 million hours

Ordering Information

Operation Temp.	4GB	8GB	16GB	32GB	64GB
Standard Grade (0°C ~ +70°C)	DESML-04GD08SCADB*	DESML-08GD08SCAQB*	DESML-16GD08SCAQB*	DESML-32GD08SCAQB*	DESML-64GD08SCAQB*
Industrial Grade (-40°C ~ +85°C)	DESML-04GD08SWADB*	DESML-08GD08SWAQB*	DESML-16GD08SWAQB*	DESML-32GD08SWAQB*	DESML-64GD08SWAQB*

*. A: Pin8+power cable / B: Pin8+Pin 7

innodisk

www.innodisk.com