

# USB EDC Horizontal 2ME2

**Customer:**

---

**Customer**

**Part Number:**

---

**Innodisk**

**Model Name:**

---

**Date:**

---

<b>Innodisk Approver</b>	<b>Customer Approver</b>

## Table of contents

<b>TABLE OF CONTENTS</b> .....	<b>2</b>
<b>LIST OF FIGURES</b> .....	<b>4</b>
<b>LIST OF TABLES</b> .....	<b>5</b>
<b>1. PRODUCT OVERVIEW</b> .....	<b>6</b>
<b>1.1 INTRODUCTION OF USB EDC</b> .....	<b>6</b>
<b>1.2 PRODUCT VIEW</b> .....	<b>6</b>
<b>1.3 PRODUCT MODELS</b> .....	<b>6</b>
<b>1.4 CAPACITY</b> .....	<b>6</b>
<b>1.5 VID/PID</b> .....	<b>6</b>
<b>2. THEORY OF OPERATION</b> .....	<b>7</b>
<b>2.1 OVERVIEW</b> .....	<b>7</b>
<b>2.2 ERROR DETECTION AND CORRECTION</b> .....	<b>7</b>
<b>2.3 WEAR-LEVELING</b> .....	<b>8</b>
<b>2.4 BAD BLOCKS MANAGEMENT</b> .....	<b>8</b>
<b>3. SPECIFICATIONS</b> .....	<b>9</b>
<b>3.1 CE AND FCC COMPATIBILITY</b> .....	<b>9</b>
<b>3.2 RoHS COMPLIANCE</b> .....	<b>9</b>
<b>3.3 ENVIRONMENTAL SPECIFICATIONS</b> .....	<b>9</b>
<b>3.4 PIN ASSIGNMENT</b> .....	<b>10</b>
<b>3.5 MECHANICAL DIMENSIONS</b> .....	<b>11</b>
<b>3.6 WEIGHT</b> .....	<b>11</b>
<b>3.7 PERFORMANCE</b> .....	<b>12</b>
<b>3.8 NAND FLASH MEMORY</b> .....	<b>12</b>
<b>4. ELECTRICAL SPECIFICATIONS</b> .....	<b>13</b>
<b>4.1 OPERATING CONDITIONS</b> .....	<b>13</b>
<b>4.2 POWER CONSUMPTION</b> .....	<b>13</b>
<b>4.3 DEVICE PARAMETERS</b> .....	<b>13</b>
<b>5. SMART FEATURE SET</b> .....	<b>14</b>
<b>5.1 SMART ATTRIBUTES</b> .....	<b>14</b>
<b>5.2 INNODISK SMART TOOL</b> .....	<b>14</b>
<b>6. PART NUMBER RULE</b> .....	<b>15</b>

## REVISION HISTORY

<b>Revision</b>	<b>Description</b>	<b>Date</b>
V1.0	First release	Dec., 2021
V1.1	Update PID info.	May, 2022
V1.2	Revise Mechanical Dimensions	Apr., 2024

## List of Figures

<b>FIGURE 1: USB EDC HORIZONTAL 2ME2</b> .....	6
<b>FIGURE 2: USB EDC HORIZONTAL 2ME2 BLOCK DIAGRAM</b> .....	7
<b>FIGURE 3: USB EDC HORIZONTAL 2ME2 MECHANICAL DIMENSIONS (PIN PITCH: 2.00MM)</b> .....	11
<b>FIGURE 4: USB EDC HORIZONTAL 2ME2 MECHANICAL DIMENSIONS (PIN PITCH: 2.54MM)</b> .....	11

## List of Tables

<b>TABLE 1: SHOCK/VIBRATION TESTING FOR USB EDC HORIZONTAL 2ME2</b> .....	9
<b>TABLE 2: USB EDC HORIZONTAL 2ME2 MTBF</b> .....	10
<b>TABLE 3: USB EDC HORIZONTAL 2ME2 TBW</b> .....	10
<b>TABLE 4: USB EDC HORIZONTAL 2ME2 PIN ASSIGNMENT</b> .....	10
<b>TABLE 5: PERFORMANCE</b> .....	12
<b>TABLE 6: USB EDC OPERATING CONDITIONS</b> .....	13
<b>TABLE 7: POWER CONSUMPTION</b> .....	13
<b>TABLE 8: DEVICE PARAMETERS</b> .....	13
<b>TABLE 9: SMART COMMAND</b> .....	14
<b>TABLE 10: SMART ATTRIBUTES</b> .....	14
<b>TABLE 11: SSD INFORMATION THROUGH INNODISK SMART TOOL</b> .....	14

# 1. Product Overview

## 1.1 Introduction of USB EDC

The Innodisk USB EDC (Embedded Disk Card) products provide high capacity USB flash memory storage that electrically complies with USB 2.0. The device features attractive small form factor and the connectivity over USB2.0 and the NAND flash architecture provide a faster data transmission.

## 1.2 Product View



Figure 1: USB EDC Horizontal 2ME2

## 1.3 Product Models

USB EDC Horizontal 2ME2 is available in follow capacities:

[USB EDC Horizontal 2ME2 8GB](#)

[USB EDC Horizontal 2ME2 16GB](#)

[USB EDC Horizontal 2ME2 32GB](#)

[USB EDC Horizontal 2ME2 64GB](#)

[USB EDC Horizontal 2ME2 128GB](#)

## 1.4 Capacity

USB EDC Horizontal 2ME2 provides within MLC Flash IC.

## 1.5 VID/PID

Default is 196D/B232.

## 2. Theory of operation

### 2.1 Overview

Figure 2 shows the operation of USB EDC Horizontal 2ME2 from the system level, including the major hardware blocks.

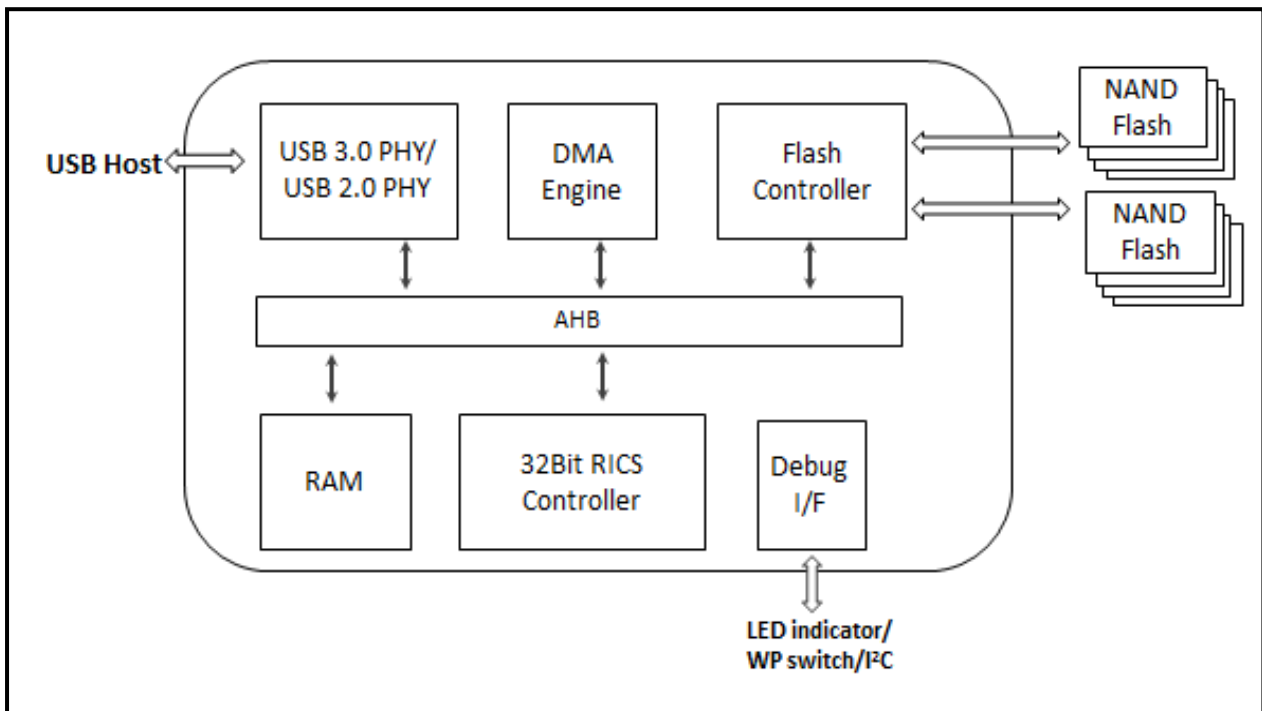

**Figure 2: USB EDC Horizontal 2ME2 Block Diagram**

USB EDC Horizontal 2ME2 integrates a USB2.0 controller and NAND flash memories. Communication with the host occurs through the host interface. Communication with the flash device(s) occurs through the flash interface.

### 2.2 Error Detection and Correction

Highly sophisticated Error Correction Code algorithms are implemented. The ECC unit consists of the Parity Unit (parity-byte generation) and the Syndrome Unit (syndrome-byte computation). This unit implements an algorithm that can correct 96 bits per 1024 bytes in an ECC block. Code-byte generation during write operations, as well as error detection during read operation, is implemented on the fly without any speed penalties.

## **2.3 Wear-Leveling**

Flash memory can be erased within a limited number of times. This number is called the *erase cycle limit* or *write endurance limit* and is defined by the flash array vendor. The erase cycle limit applies to each individual erase block in the flash device.

USB EDC Horizontal 2ME2 uses a static wear-leveling algorithm to ensure that consecutive writes of a specific sector are not written physically to the same page/block in the flash. This spreads flash media usage evenly across all pages, thereby extending flash lifetime.

## **2.4 Bad Blocks Management**

Bad Blocks are blocks that contain one or more invalid bits whose reliability are not guaranteed. The Bad Blocks may be presented while the SSD is shipped, or may generate during the life time of the SSD. When the Bad Blocks is detected, it will be flagged, and not be used anymore. The SSD implement Bad Blocks management and replacement, Error Correct Code to avoid data error occurred. The functions will be enabled automatically to transfer data from Bad Blocks to spare blocks, and correct error bit.



# 3. Specifications

## 3.1 CE and FCC Compatibility

USB EDC Horizontal 2ME2 conforms to CE and FCC requirements.

## 3.2 RoHS Compliance

USB EDC Horizontal 2ME2 is fully compliant with RoHS directive.

## 3.3 Environmental Specifications

### 3.3.1 Temperature Ranges

Operating Temperature Range:

- Standard Grade: 0°C ~ +70°C
- Industrial Grade: -40°C to +85°C

Storage Temperature Range:

- Standard Grade: -40°C to +85°C

### 3.3.2 Humidity

Relative Humidity: 10-95%, non-condensing

### 3.3.3 Shock and Vibration

Reliability	Test Conditions	Reference Standards
Vibration	7 Hz to 2K Hz, 20G, 3 axes	IEC 68-2-6
Mechanical Shock	Duration: 0.5ms, 1500G, 3 axes	IEC 68-2-27

**Table 1: Shock/Vibration Testing for USB EDC Horizontal 2ME2**

### 3.3.4 Mean Time between Failures (MTBF)

Table 2 summarizes the MTBF prediction results for various USB EDC Horizontal 2ME2 configurations. The analysis was performed using a RAM Commander™ failure rate prediction.

- Failure Rate: The total number of failures within an item population, divided by the total number of life units expended by that population, during a particular measurement interval under stated condition.

- Mean Time between Failures (MTBF): A basic measure of reliability for repairable items: The mean number of life units during which all parts of the item perform within their specified limits, during a particular measurement interval under stated conditions.

Product	Condition	MTBF (Hours)
USB EDC Horizontal 2ME2	Telcordia SR-332 GB, 25°C	>3,000,000

**Table 2: USB EDC Horizontal 2ME2 MTBF**

### 3.3.5 Terabyte Written (TBW)

Parameter	Value
<b>Flash endurance</b>	3,000 P/E cycles
<b>TBW* (Total Bytes Written) Unit:TB</b>	
<b>Capacity</b>	<b>(Sequential Write)</b>
8GB	21.6
16GB	43.2
32GB	86.4
64GB	172.8
128GB	345.6

**Table 3: USB EDC Horizontal 2ME2 TBW**

### 3.4 Pin Assignment

USB EDC Horizontal 2ME2 is designed within USB2.0 Interface. Particularly, its built-in power pin enables the device more compactable. Table 4 demonstrates USB EDC Horizontal 2ME2 pin assignments.

<b>Horizontal Type</b>			
<b>Pin No.</b>	<b>Signal</b>	<b>Pin No.</b>	<b>Signal</b>
<b>1</b>	+5V DC	<b>2</b>	NC (None connect)
<b>3</b>	USB Data(-)	<b>4</b>	NC (None connect)
<b>5</b>	USB Data(+)	<b>6</b>	NC (None connect)
<b>7</b>	GND	<b>8</b>	NC (None connect)
<b>9</b>	NC (None connect)	<b>10</b>	NC (None connect)

**Table 4: USB EDC Horizontal 2ME2 Pin Assignment**

### 3.5 Mechanical Dimensions

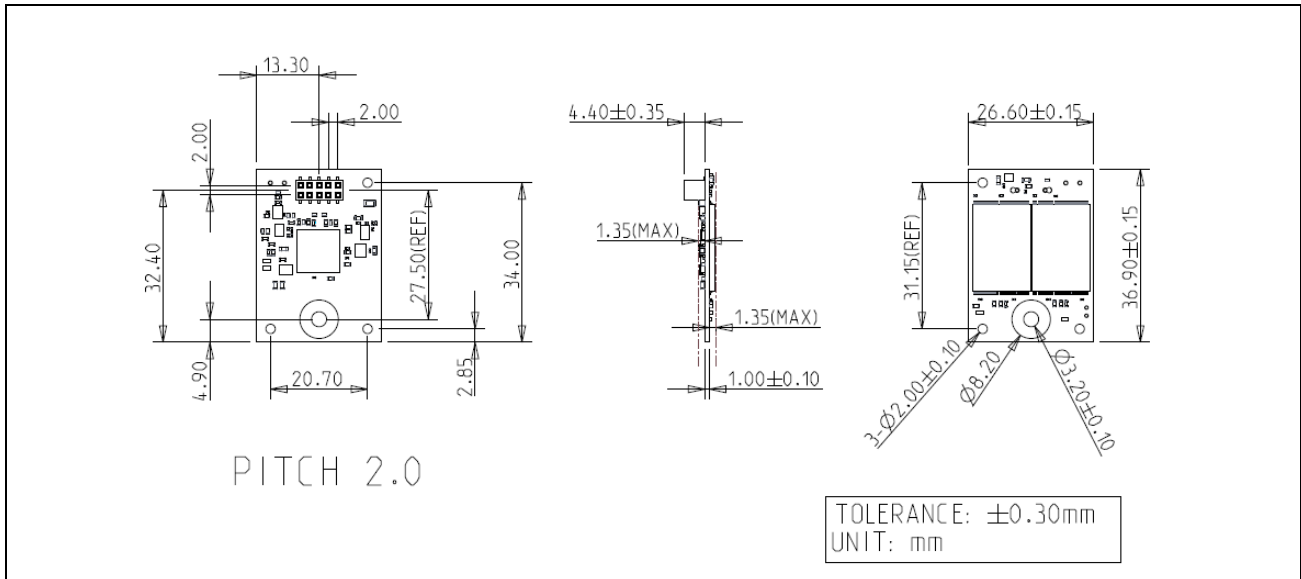

Figure 3: USB EDC Horizontal 2ME2 mechanical dimensions (Pin Pitch: 2.00mm)

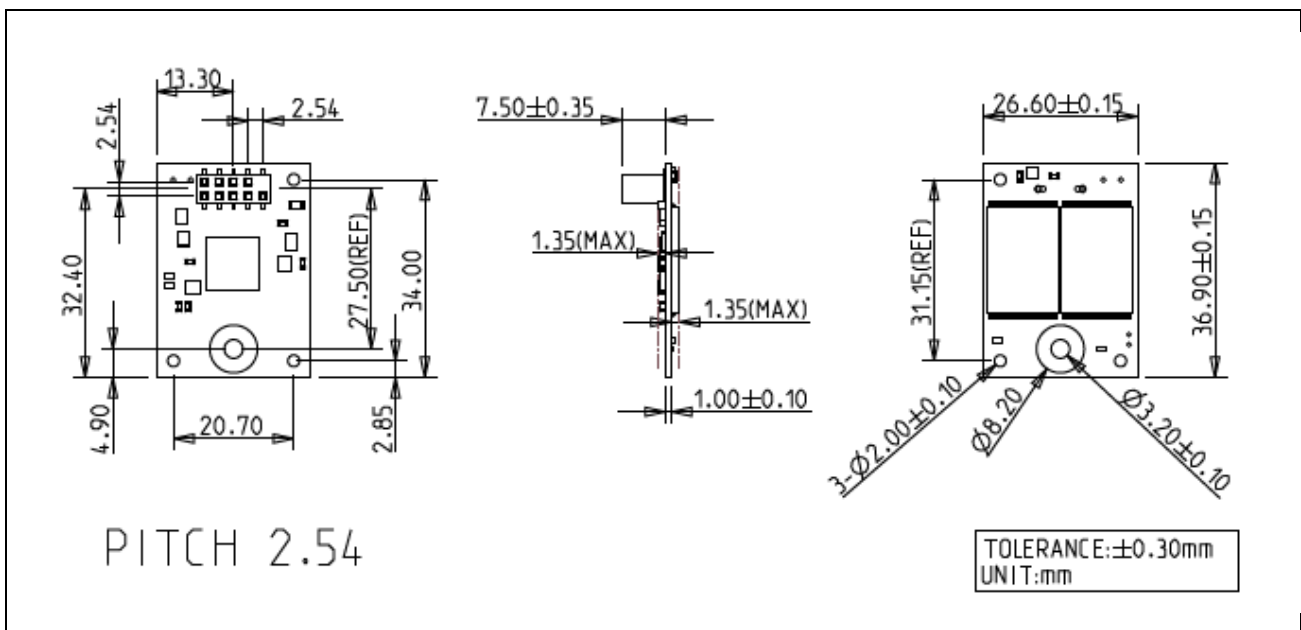

Figure 4: USB EDC Horizontal 2ME2 mechanical dimensions (Pin Pitch: 2.54mm)

### 3.6 Weight

5g $\pm$ 2

### 3.7 Performance

**Table 5: Performance**

Capacity	Unit	8GB	16GB	32GB	64GB	128GB
Sequential Read (Q32T1)	MB/s	35	35	40	40	40
Sequential Write(Q32T1)		20	20	25	25	25

Note: \* Performance results are measured in Room Temperature with Out-of-Box devices and may vary depending on overall system setup.

Note: \*\* Performance results are based on CrystalDiskMark 6.0.2 with typical tolerances for range from 1% to 10%.

### 3.8 NAND Flash Memory

USB EDC Horizontal 2ME2 uses Multi-Level Cell (MLC) NAND flash memory, which is non-volatility, high reliability.

## 4. Electrical Specifications

### 4.1 Operating Conditions

Item	Symbol	Rating	Unit
USB supply voltage	USBVin	+5 DC+-5%	V

**Table 6: USB EDC Operating Conditions**

Note. For 3.3V power supply please contact sales for customization

### 4.2 Power Consumption

Mode	Power Consumption (W)
Read	0.39
Write	0.45
Idle	0.22

**Table 7: Power Consumption**

Target: 128GB USB EDC H 2ME2

Note: Current results may vary depending on system components and power circuit design. Please refer to the test report for other capacities.

### 4.3 Device Parameters

USB EDC device parameters listed in Table 8.

Capacity	LBA	User Capacity(MB)
8GB	15649200	7,641
16GB	31277232	15,272
32GB	62533296	30,534
64GB	125045424	61,057
128GB	250069680	122,104

**Table 8: Device parameters**

# 5. SMART Feature Set

Innodisk USB EDC H 2ME2 series support the SMART command set and defines some vendor-specific data to report SMART attributes of SSD.

**Table 9: SMART command**

Value	Command
D0h	Read Data
D1h	Read Attribute Threshold
D8h	Enable SMART Operations
D9h	Disable SMART Operations
DAh	Return Status

## 5.1 SMART Attributes

Innodisk USB EDC H 2ME2 series SMART data attributes are listed in following table.

Attribute ID (hex)	Value	Raw Attribute Value						Rsv	Attribute Name
0C	x	LSB			MSB				Number of power on
C2	x	LSB							Current temperature
D5	x				LSB		MSB		Number of current spare block
E5	x	LSB					MSB		Est. total number of block erase
F1	x	LSB					MSB		Total number LBAs written
F2	x	LSB					MSB		Total number LBA read

**Table 10: SMART Attributes**

## 5.2 Innodisk SMART tool

Innodisk USB EDC H 2ME2 series support Innodisk USB SMART tool which can further display SSD information listing in following table.

**Table 11: SSD information through Innodisk SMART tool**

Uncorrectable ECC Error	Uncorrectable error count
Average Erase Count	The average erases count of all blocks.
Early Bad Block Count	Number of initial invalid block
Later Bad Block Count	Bad blocks occurred during operation.
Health	(PE cycle – Average Erase Count)/PE Cycle

# 6. Part Number Rule

	1	2	3	4	5	6	7	8	9	10	11	12	13	14	15	16	17	18	19	20	21	22
	<b>D</b>	<b>E</b>	<b>U</b>	<b>H</b>	<b>1</b>	<b>-</b>	<b>1</b>	<b>6</b>	<b>G</b>	<b>D</b>	<b>Q</b>	<b>1</b>	<b>B</b>	<b>W</b>	<b>1</b>	<b>S</b>	<b>C</b>	<b>-</b>	<b>X</b>	<b>X</b>	<b>X</b>	<b>X</b>
Description	Disk	Form Factor			-	Capacity			Category			Flash mode	Operation Temp.	PCB Version	Channel	Flash	Customized Code					
<b>Definition</b>																						
<b>Code 1<sup>st</sup> (Disk)</b>												<b>Code 14<sup>th</sup> (Operation Temperature)</b>										
D: Disk												C: Standard Grade (0°C~ +70°C)										
												W: Industrial Grade (-40°C~ +85°C)										
<b>Code 2<sup>nd</sup> ~ 4<sup>th</sup> (Form Factor)</b>												<b>Code 15<sup>th</sup> (Internal control)</b>										
EUH: USB EDC Horizontal												1~9: TSOP PCB version										
<b>Code 5<sup>th</sup> (Pin pitch)</b>												<b>Code 16<sup>th</sup> (Channel)</b>										
1: 2.54mm												S: Single channel										
2: 2.00mm																						
<b>Code 7<sup>th</sup> ~9<sup>th</sup> (Capacity)</b>												<b>Code 17<sup>th</sup> (Flash)</b>										
08G: 8GB												C: Kioxia MLC										
16G: 16GB																						
32G: 32GB												<b>Code 19<sup>th</sup> ~ 21<sup>st</sup> (Customize code)</b>										
64G: 64GB																						
A28: 128GB																						
<b>Code 10<sup>th</sup> ~12<sup>th</sup> (Category)</b>																						
DQ1: USB EDC H 2ME2 series																						
<b>Code 13<sup>th</sup> (Flash mode)</b>																						
B: Kioxia 15nm MLC																						