

R15IE3S-65EX

15" Intel® Atom® x6413E ATEX Panel PC



KEY FEATURES

- Intel Atom® x6413E Processor 1.5M Cache, up to 3.00 GHz
- High Quality 15" Panel, 1024 x 768 resolution, 1000 nits
- P-cap multi touch screen Optical Bonding with Panel to increase the clarity and transparency
- Compliance with ATEX / IECEx / CID2 Design
- Fanless design with streamlined enclosure for highly efficient heat dissipation
- Dust/ Water proof design with VESA mount Full IP65 Panel PC
- Wide Range 9 to 36V DC Input with isolation
- -20 to 60°C wide operating temperature



SPECIFICATIONS

System Specification

Processor	Intel Atom® x6413E (up to 3.0GHz)	Memory	1 x SO-DIMM, DDR4 3200 MHz, 4GB 8GB (Optional) 16GB (Optional)
Storage	1 x M.2 2242 B-key SSD 128GB 256GB (Optional) 512GB (Optional)	Ethernet controller	1 x Intel® Ethernet Controller
Operating System	Windows 11 IoT Enterprise (64 bit) (Optional) Windows 11 Pro 64 bit (Optional) Windows 10 IoT Enterprise (64 bit) (Optional) Linux Ubuntu 22.04 (Optional)		

Display

Touch / Glass	Projected Capacitive Multi Touch Screen Bonding With Panel	Resolution	1024x768
Size	15.0 inches	Contrast Ratio	2000:1
Panel Brightness	550 nits 1000 nits(Optional)	View Angles	88,88,88,88
Active Area	304.1x228.1 mm		

Mechanical

Dimension	396 x 310 x 49 mm (Without Box Cover) 396 x 346.4 x 101.7 mm (With Box Cover)	Weight	5.7 kg (Without Box Cover) 10.2 Kg (With Box Cover)
Mounting	VESA Mount	Enclosure	Stainless Housing
Cooling System	Fanless design		

Environment

Operating Humidity	10% to 95% RH, Non-Condensing	Operating Temperature	-20°C to 60°C
Storage Temperature	-30°C to 70°C	Shock	MIL-STD-810G Method 516.6 Procedure I (Optional)
Vibration	MIL-STD-810G Method 514.6 Procedure I	IP rating	IP65
Drop	MIL-STD-810G Method 516.6 Procedure IV		

Certification

Certification	CE, FCC, IC Compliance with ATEX / IECEx / CID2 Design
----------------------	---

IO Ports			
Power Input	1 x 9~36V DC, M12 Type connector	USB Port	1x M12 type connector for 2 x USB2.0
Serial Port	1 x M12 connector for RS232/422/485 (Default RS232)	Expansion Port	1 x M.2 2242 B-key Slot (for SATA III SSD) 1 x M.2 2230 E-Key Slot (for Wi-Fi module)
LAN	1 x M12 type connector for Giga LAN	Indicator	1 x LED Indicator for power 1 x LED Indicator for storage
Control			

Button	1 x Power Button 1 x Reset Button
---------------	--------------------------------------

Accessory	
Accessory	100~240V AC to DC Power Adapter with M12 Connector Power Cord M12 Type Power Cable M12 Type RS232 Male Cable M12 Type USB Female Cable M12 Type LAN Cable RJ45 female-female converter USB Adapter (USB type A to type B) VESA screws

DIMENSIONS UNIT:MM

w/o Box Cover

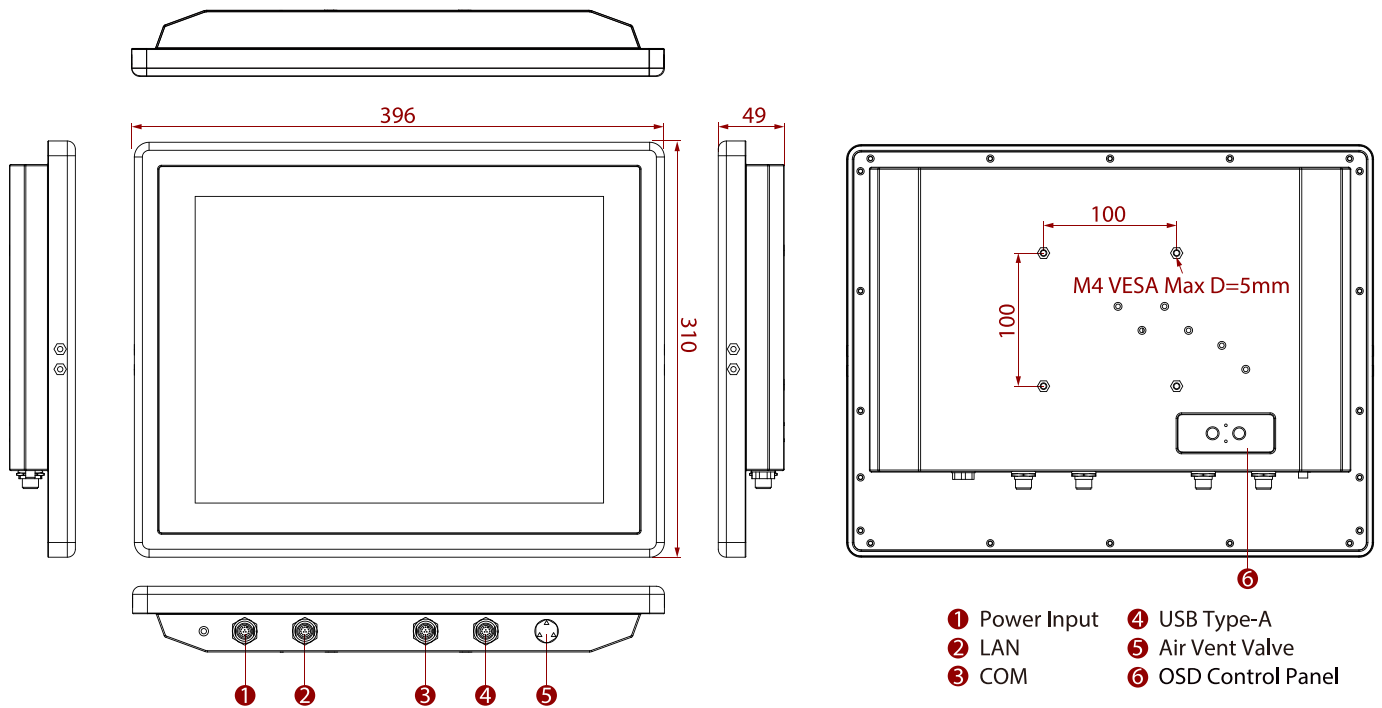

With Box Cover

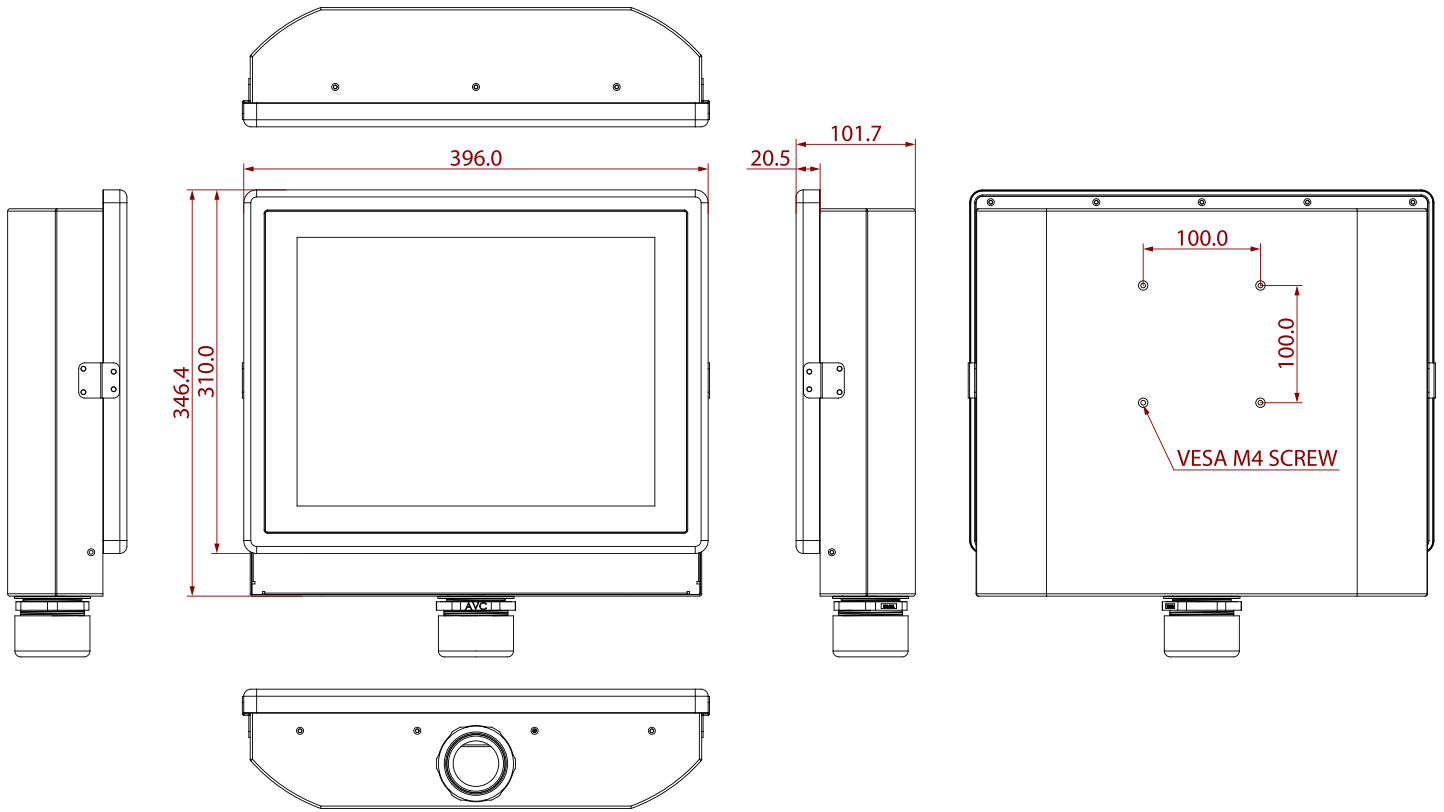

NOTE

1. This is a simplified drawing and some components are not marked in detail.
2. Please contact our sales representative if you need further product information.
3. All specifications are subject to change without prior notice.
4. The product shown in this datasheet is a standard model. For diagrams that contain customized or optional I/O, please contact the Winmate Sales Team for more information.