

ESPL-G401

PCIe to Four

GbE LAN Module

Customer:

Customer

Part Number:

Innodisk

Part Number:

Innodisk

Model Name:

Date:

Innodisk	Customer
Approver	Approver

Table of Contents

- TABLE OF CONTENTS I**
- REVISION HISTORYII**
- LIST OF TABLES 1**
- LIST OF FIGURES 2**
- 1. PRODUCT INTRODUCTION 3**
 - 1.1. OVERVIEW 3
 - 1.2. FEATURES 3
- 2. PRODUCT SPECIFICATIONS 4**
 - 2.1. DEVICE PARAMETERS 4
 - 2.2. ELECTRICAL SPECIFICATIONS 4
 - 2.2.1.POWER REQUIREMENT 4
 - 2.2.2.POWER CONSUMPTION 4
 - 2.3. ENVIRONMENTAL SPECIFICATIONS 4
 - 2.3.1.TEMPERATURE RANGES 4
 - 2.3.2.HUMIDITY 5
 - 2.3.3.SHOCK AND VIBRATION 5
 - 2.3.4.MEAN TIME BETWEEN FAILURE (MTBF) 5
 - 2.4. CE AND FCC COMPATIBILITY 5
 - 2.5. ROHS COMPLIANCE 5
 - 2.6. HARDWARE..... 5
 - 2.6.1.LAYOUT 5
 - 2.6.2.PIN DEFINE 6
 - 2.6.3.ESPL-G401 MECHANICAL DRAWING 7
 - 2.6.4.PACKING LIST 8
 - 2.7. SOFTWARE SUPPORT..... 8
- 3. INSTALLATION GUIDE 8**
- 4. APPEDIX 9**
- CONTACT US..... 11**

REVISION HISTORY

Revision	Description	Date
1.0	First Released	Nov, 2022
1.1	Correct 2.2.1 Power Requirement information	May, 2024

List of Tables

TABLE 1: DEVICE PARAMETERS 4

TABLE 2: POWER REQUIREMENT..... 4

TABLE 3: POWER CONSUMPTION 4

TABLE 4: TEMPERATURE RANGES..... 4

TABLE 5: SHOCK AND VIBRATION 5

TABLE 6: MEAN TIME BETWEEN FAILURE (MTBF)..... 5

TABLE 7: PCIe X 4 GOLDEN FINGER PIN DEFINE 6

List of Figures

FIGURE 1: BLOCK DIAGRAM 3
FIGURE 2: PCIe BOARD PICTURE 3
FIGURE 3: ESPL-G401 PCIe BOARD DRAWING 8

1. Product Introduction

1.1. Overview

Innodisk ESPL-G401 is designed with Standard PCIe form factor, ESPL-G401 supports PCIe Gen 2.1 with a single lane to four GbE LAN ports, optimized for higher performance and lower power, which brings you a flexible expansion solution for embedded systems.

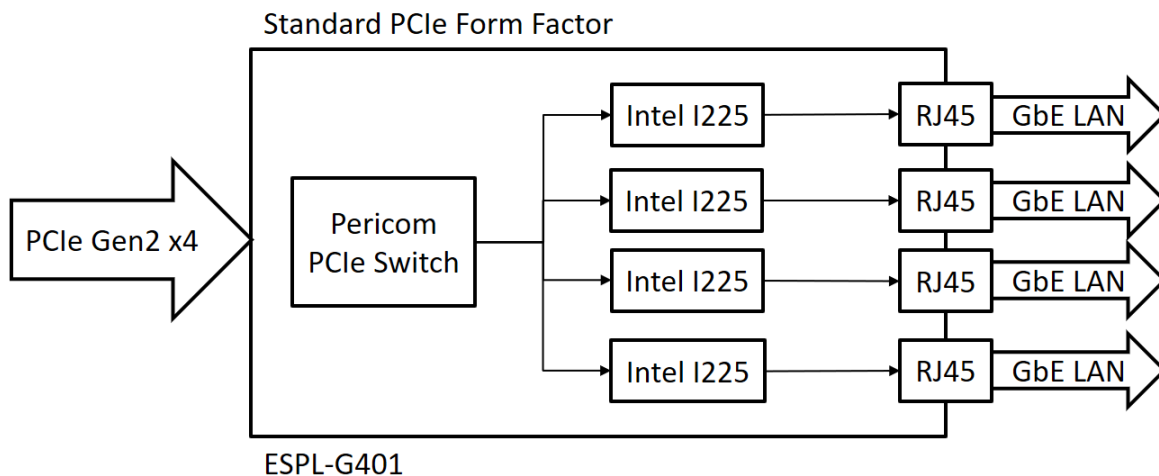

Figure 1: Block Diagram

1.2. Features

- Supports four GbE LAN ports
- Complies with EN61000-4-5 2kV Surge protection
- Optional Industrial Temperature (-40°C to +85°C) support
- 30μ" golden finger, 3-year warranty
- Industrial design, manufactured in innodisk Taiwan



Figure 2: PCIe Board Picture

2. Product Specifications

2.1. Device Parameters

Table 1: Device Parameters

Form Factor	Standard PCIe
Input I/F	PCI Express 2.1 x 4
Output I/F	GbE LAN x 4
Output Connector	RJ45 x 4
Dimension (WxLxH)	169.55 x 111.15 x 17.52 mm

2.2. Electrical Specifications

2.2.1. Power Requirement

Table 2: Power Requirement

Item	Connector	Rating
Input voltage	PCIex4 Golden Finger	+3.3/12V DC +-5%

2.2.2. Power Consumption

Table 3: Power Consumption

Max (W)	Voltage(V)	Max (mA)
7.42	3.3	636
	12	443

2.3. Environmental Specifications

2.3.1. Temperature Ranges

Table 4: Temperature Ranges

Temperature	Range
Operating	Standard Grade: 0°C to +70°C Industrial Grade: -40°C to +85°
Storage	-55°C to +95°

2.3.2. Humidity

Relative Humidity: 10-95%, non-condensing

2.3.3. Shock and Vibration

Table 5: Shock and Vibration

Reliability	Test Conditions	Reference Standards
Vibration	7 Hz to 2K Hz, 20G, 3 axes	IEC 68-2-6
Mechanical Shock	Duration: 0.5ms, 1500 G, 3 axes	IEC 68-2-27

2.3.4. Mean Time between Failure (MTBF)

Reliability prediction methodology provides the basis for reliability evaluation and analysis. The purpose of the prediction is to predict the life time of the product in units of failure rate and MTBF.

Table 6: Mean Time between Failure (MTBF)

Product	Condition	MTBF (Hours)
ESPL-G401-C1/W1	The analysis is at 25°C ambient temperature by Telcordia SR-332, Issues 4, Method I, Case 3 under Ground Benign, Controlled environment, 50% operation stress	3,689,288

2.4. CE and FCC Compatibility

ESPL-G401 conforms to CE and FCC requirements.

2.5. RoHS Compliance

ESPL-G401 is fully compliant with RoHS directive.

2.6. Hardware

2.6.1. Layout

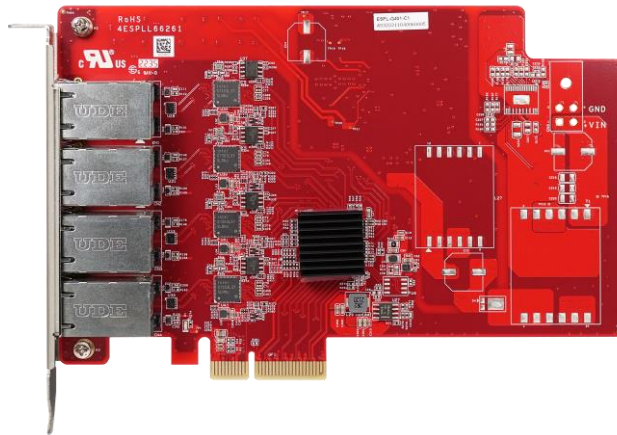

2.6.2. Pin Define

Table 7: PCIe x 4 Golden Finger Pin Define

Signal Name	Pin #	Pin #	Signal Name
+12V	B1	A1	PRSNT
+12V	B2	A2	+12V
+12V	B3	A3	+12V
GND	B4	A4	GND
SMCLK	B5	A5	NC
SMDAT	B6	A6	NC
GND	B7	A7	NC
+3.3V	B8	A8	NC
NC	B9	A9	+3.3V
NC	B10	A10	+3.3V
WAKE	B11	A11	PERST
Mechanical Key			
NC	B12	A12	GND
GND	B13	A13	REFCLK+
RX0+	B14	A14	REFCLK-
RX0-	B15	A15	GND
GND	B16	A16	TX0+

PRSNT	B17	A17	TX0-
GND	B18	A18	GND
RX1+	B19	A19	NC
RX1-	B20	A20	GND
GND	B21	A21	TX1+
GND	B22	A22	TX1-
RX2+	B23	A23	GND
RX2-	B24	A24	GND
GND	B25	A25	TX2+
GND	B26	A26	TX2-
RX3+	B27	A27	GND
RX3-	B28	A28	GND
GND	B29	A29	TX3+
NC	B30	A30	TX3-
PRSNT	B31	A31	GND
GND	B32	A32	NC

2.6.3. ESPL-G401 Mechanical Drawing

4. Appedix

innodisk

宜鼎國際股份有限公司 Innodisk Corporation REACH Declaration

Tel:(02)7703-3000 Fax:(02) 7703-3555 Internet: <https://www.innodisk.com/>

Innodisk Corporation pursues its social responsibility for global environmental preservation by committing to be compliant with REACH regulation (REGULATION (EC) No 1907/2006). We hereby confirm that the product(s),

Scope: Flash Memory, DRAM Module and Embedded Peripherals Products.

- The standard products of **not listed in the Appendix2** meet the requirements of REACH SVHC regulations(SVHCs < 0.1% in Article), as described in the candidate list table currently including 240 substances (release date: 23-JAN-2024) and shown on the ECHA website. <https://echa.europa.eu/candidate-list-table>
- The standard products listed in the **Appendix2** contain(s) one or more hazardous substances or constituents exceeding 0.1 % by weight in article if not otherwise specified in candidate list table.
Where the threshold value is exceeded, the substances in question are to be declared in accompanying. (SVHCs > 0.1% in Article).
- Comply with REACH Annex XVII.



Guarantor

Company name 公司名稱：Innodisk Corporation 宜鼎國際股份有限公司

Company Representative 公司代表人： Yichuan Chen 陳怡全

Company Representative Title 公司代表人職稱：Quality Assurance Div. SR. Manager 品保處經理

Date 日期：2024 / 02 / 19

RoHS 自我宣告書(RoHS Declaration of Conformity)

Manufacturer Products: All Innodisk EM FLASH, DRAM and EP products

- 一、宜鼎國際股份有限公司（以下稱本公司）特此保證售予貴公司之所有產品，皆符合歐盟 2011/65/EU 及(EU) 2015/863 關於 RoHS 之規範要求。
Innodisk Corporation declares that all products sold to the company, are complied with European Union RoHS Directive (2011/65/EU) and (EU) 2015/863 requirement.
- 二、本公司同意因本保證書或與本保證書相關事宜有所爭議時，雙方宜友好協商，達成協議。
Innodisk Corporation agrees that both parties shall settle any dispute arising from or in connection with this Declaration of Conformity by friendly negotiations.
- 三、本公司聲明我們的產品符合 RoHS 指令的附件中 7(a)、7(c)-I、6(c)允許豁免。
We declare, our products permitted by the following exemptions specified in the Annex of the RoHS directive.
- ※ 7(a) Lead in high melting temperature type solders(i.e. lead-based alloys containing 85% by weight or more lead).
 - ※ 7(c)-I Electrical and electronic components containing lead in a glass or ceramic other than dielectric ceramic in capacitors, e.g. piezoelectric devices, or in a glass or ceramic matrix compound.
 - ※ 6(c) Copper alloy containing up to 4% lead by weight. (This exemption applies to products that use antennas)

Name of hazardous substance	Limited of RoHS ppm (mg/kg)
鉛 (Pb)	< 1000 ppm
汞 (Hg)	< 1000 ppm
鎘 (Cd)	< 100 ppm
六價鉻 (Cr 6+)	< 1000 ppm
多溴聯苯 (PBBs)	< 1000 ppm
多溴二苯醚 (PBDEs)	< 1000 ppm
鄰苯二甲酸二(2-乙基己基)酯 (DEHP)	< 1000 ppm
鄰苯二甲酸丁酯苯甲酯 (BBP)	< 1000 ppm
鄰苯二甲酸二丁酯 (DBP)	< 1000 ppm
鄰苯二甲酸二異丁酯 (DIBP)	< 1000 ppm

立保證書人 (Guarantor)

Company name 公司名稱: Innodisk Corporation 宜鼎國際股份有限公司

Company Representative 公司代表人: 簡川勝

Company Representative Title 公司代表人職稱: Chairman 董事長

Date 日期: 2023 / 06 / 14

Contact us

Headquarters (Taiwan)

5F., No. 237, Sec. 1, Datong Rd., Xizhi Dist., New Taipei City 221, Taiwan

Tel: +886-2-77033000

Email: sales@innodisk.com

Branch Offices:

USA

usasales@innodisk.com

+1-510-770-9421

Europe

eusales@innodisk.com

+31-40-3045-400

Japan

jpsales@innodisk.com

+81-3-6667-0161

China

sales_cn@innodisk.com

+86-755-2167-3689

www.innodisk.com

© 2018 Innodisk Corporation.

All right reserved. Specifications are subject to change without prior notice.

May 16, 2024