

SD100-Q170

Desktop

Q170

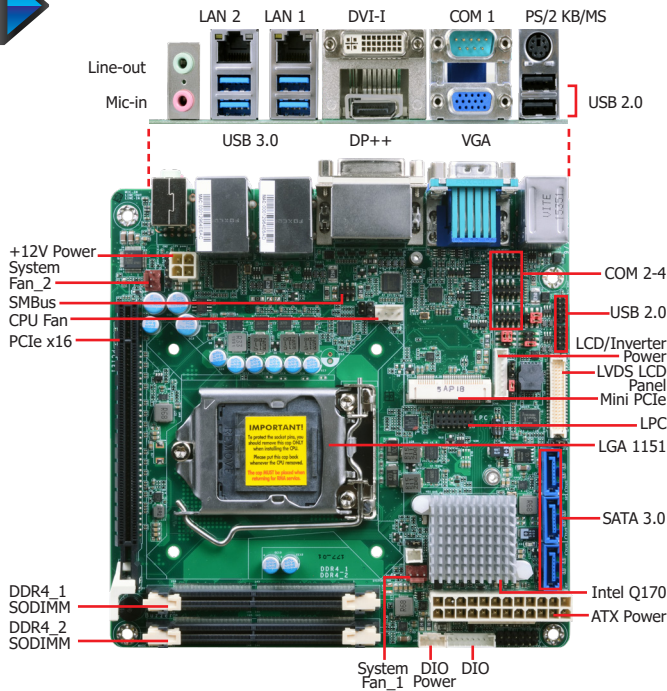

Features

- 2 DDR4 SODIMM up to 32GB
- Four display ports support three independent displays: VGA + LVDS + DVI-I + DP++
- DP++ resolution up to 4096x2304 @ 60Hz
Dual Channel LVDS resolution up to 1920x1200 @ 60Hz
- Multiple expansion: 1 PCIe x16, 1 Mini PCIe
- Rich I/O: 2 Intel GbE, 4 COM, 4 USB 3.0, 6 USB 2.0
- LPC EXT-RS232/485 module extends additional 4 COM ports



2 Extension Modules for Additional 4 COM Ports (via the LPC connector)

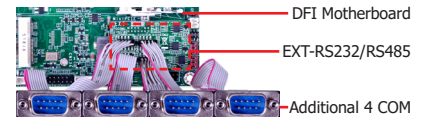

Ordering Information

Model Name	P/N	Memory	GbE	RS-232/422/485	RS-232	USB 3.0	USB 2.0	Power	Thermal	Temp.
SD100-Q170NRM	770-SD1005-000G	2 SODIMM	2	1	3	4	6	24-pin ATX	Active	0 to 60°C

Mechanical Drawing

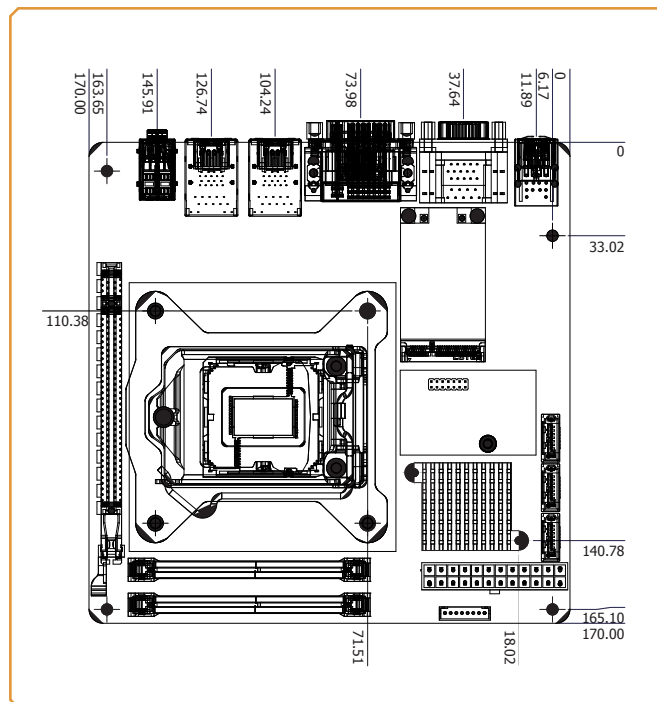

Block Diagram

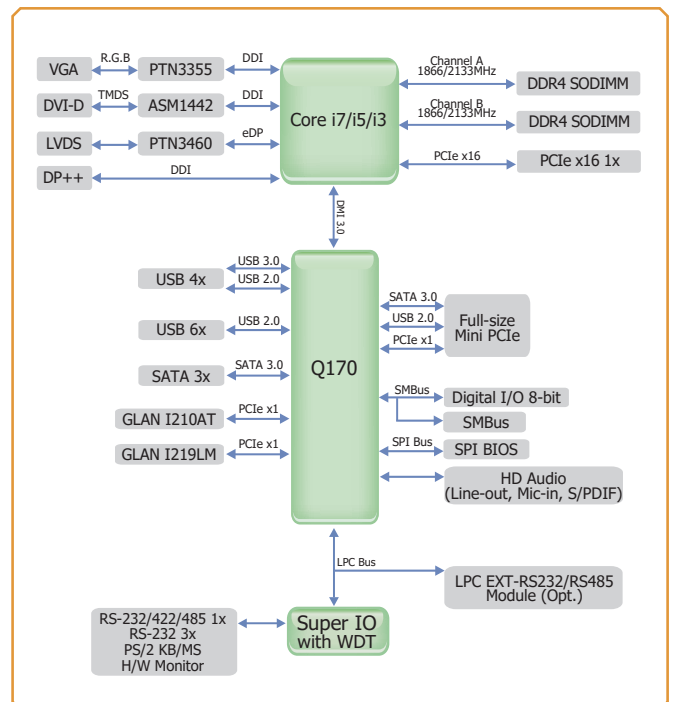

Specifications

SYSTEM	Processor	7th Generation Intel® Core™ Processors, LGA 1151 Socket Intel® Core™ i7-7700 Processor, Quad Core, 8M Cache, 3.6GHz (4.2GHz), 65W Intel® Core™ i5-7500 Processor, Quad Core, 6M Cache, 3.4GHz (3.8GHz), 65W Intel® Core™ i3-7101E Processor, Dual Core, 3M Cache, 3.9GHz, 65W 6th Generation Intel® Core™ Processors, LGA 1151 Socket Intel® Core™ i7-6700, Quad Core, 8M Cache, 3.4GHz (4.0GHz), 65W Intel® Core™ i7-6700TE, Quad Core, 8M Cache, 2.4GHz (3.4GHz), 35W Intel® Core™ i5-6500, Quad Core, 6M Cache, 3.2GHz (3.6GHz), 65W Intel® Core™ i5-6500TE, Quad Core, 6M Cache, 2.3GHz (3.3GHz), 35W Intel® Core™ i3-6100, Dual Core, 3M Cache, 3.7GHz, 47W Intel® Core™ i3-6100TE, Dual Core, 4M Cache, 2.7GHz, 35W Intel® Pentium® G4400, Dual Core, 3M Cache, 3.3GHz, 47W Intel® Pentium® G4400TE, Dual Core, 3M Cache, 2.4GHz, 35W Intel® Celeron® Processor G3900, Dual Core, 2M Cache, 2.8GHz, 65W Intel® Celeron® Processor G3900TE, Dual Core, 2M Cache, 2.6GHz, 35W	
	Chipset	Intel® Q170	
	Memory	Two 260-pin SODIMM up to 32GB	Dual Channel DDR4 1866/2133MHz
	BIOS	Insyde SPI 128Mbit	
	GRAPHICS	Controller	Intel® HD Gen 9 Graphics
	Feature	OpenGL 5.0, DirectX 12, OpenCL 2.1 HW Decode: AVC/H.264, MPEG2, VC1/WMV9, JPEG/MJPEG, HEVC/H265, VP8, VP9 HW Encode: MPEG2, AVC/H264, JPEG, HEVC/H265, VP8, VP9	
	Display	1 x VGA 1 x LVDS 1 x DVI-I (DVI-D signal) 1 x DP++	VGA: resolution up to 1920x1200 @ 60Hz LVDS: dual channel, resolution up to 1920x1200 @ 60Hz DVI-I: resolution up to 1920x1200 @ 60Hz DP: resolution up to 4096x2304 @ 60Hz
	Triple Displays	VGA + DVI-I (DVI-D signal) + DP++ LVDS + DVI-I (DVI-D signal) + DP++	VGA + LVDS + DP++ VGA + LVDS + DVI-I (DVI-D signal)
EXPANSION	Interface	1 x PCIe x16 (Gen 3)	1 x Full-size Mini PCIe (mSATA/PCIe, PCIe by default)
AUDIO	Audio Codec	Realtek ALC888S-VD2-GR	
ETHERNET	Controller	1 x Intel® I210AT PCIe (10/100/1000Mbps) 1 x Intel® I219LM PCIe with iAMT11.0 (10/100/1000Mbps) (only Core i7/i5 supports iAMT)	
REAR I/O	Ethernet	2 x GbE (RJ-45)	
	Serial	1 x RS-232 (DB-9)	
	USB	4 x USB 3.0	2 x USB 2.0
	PS/2	1 x PS/2 (mini-DIN-6)	
	Display	1 x VGA 1 x DVI-I (DVI-D signal)	1 x DP++
	Audio	1 x Line-in (available upon request) 1 x Line-out 1 x Mic-in	
	INTERNAL I/O	Serial	1 x RS-232/422/485 (RS-232 w/ power) (2.00mm pitch) 2 x RS-232 (2.00mm pitch)
	USB	4 x USB 2.0 (2.00mm pitch)	
	Display	1 x LVDS LCD Panel Connector	1 x LCD/Inverter Power
	Audio	1 x S/PDIF	
	SATA	3 x SATA 3.0 (up to 6Gb/s)	RAID 0/1
	DIO	1 x 8-bit DIO	
	LPC	1 x LPC (supports LPC EXT-RS232/RS485 module)	
	SMBus	1 x SMBus	
WATCHDOG TIMER	Output & Interval	System Reset, Programmable via Software from 1 to 255 Seconds	
POWER	Type	ATX	
	Connector	4-pin ATX 12V power	24-pin ATX power
	Consumption	Typical: i7 65W: 12V @ 2.15A (25.86Watt) Max.: i7 65W: 12V @ 5.84A (70.12Watt)	
	RTC Battery	CR2032 Coin Cell	
OS SUPPORT	Microsoft/Linux	Windows 7 (/WES7) 32/64-bit Windows 8.1 (64-bit) Windows 10 IoT Enterprise 64-bit Note: 7th Gen Intel Core processors only support Win 10.	Debian 8 (with VESA graphic driver) CentOS 7 (with VESA graphic driver) Linux
ENVIRONMENT	Temperature	Operating: 0 to 60°C	Storage: -40 to 85°C
	Humidity	Operating: 5 to 90% RH	Storage: 5 to 90% RH
	MTBF	434,530 hrs @ 25°C; 254,049 hrs @ 45°C; 162,406 hrs @ 60°C Calculation model: Telcordia Issue 2, Method 1 Case 3 Environment: GB, GC – Ground Benign, Controlled	
MECHANICAL	Dimensions	Mini-ITX Form Factor	170mm (6.7") x 170mm (6.7")
	Height	PCB: 1.6mm	Top Side: 20mm, Bottom Side: 3mm
CERTIFICATIONS	CE, FCC Class B, RoHS, UL		

Packing List

• 1 SD100-Q170 motherboard	
• 1 COM port cable (Length: 250mm, 1 x COM ports)	A81-015011-001G
• 1 Serial ATA data cable (Length: 500mm)	332-553001-005G
• I/O shield	A49-SD3300-001G

Optional Items

• USB port cable (Length: 200mm)	A81-001032-016G
• COM port cable (Length: 250mm, 1 x COM ports)	A81-015011-001G
• Serial ATA data cable (Length: 500mm)	332-553001-005G
• Thermal solution (For 35W, Height: 37.3mm)	A71-103004-000G
• Thermal solution (For 65W, Height: 74.47mm)	A71-101158-000G
• LPC EXT-RS232 module (4 x RS232 ports)	770-EXTRS1-000G
• LPC EXT-RS485 module (4 x RS485 ports)	770-EXTRS1-100G
• DT122 Chassis	761-DT1220-200G