

# ES220F-CS

## Compact Fanless Embedded System



### Package Contents

- |  |
|--|
| • 1 ES220F-CS system unit with wallmount |
| • Adapter 12V 60W (optional)             |
| • Power Cord 1830mm (optional)           |
| • VESA mounting kit (optional)           |

# Product Overview

## Front View - 1 storage

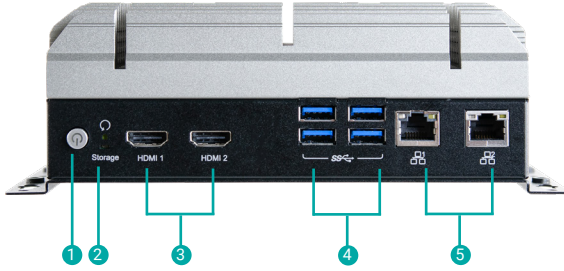

## Front View - 3 storage

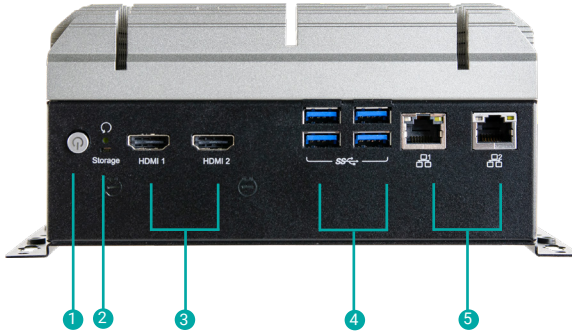

- 1** Power Button
- 2** Status LED, Reset Button
- 3** HDMI 2.0
- 4** USB 3.1
- 5** LAN 1 & LAN 2

## Rear View - 1 storage

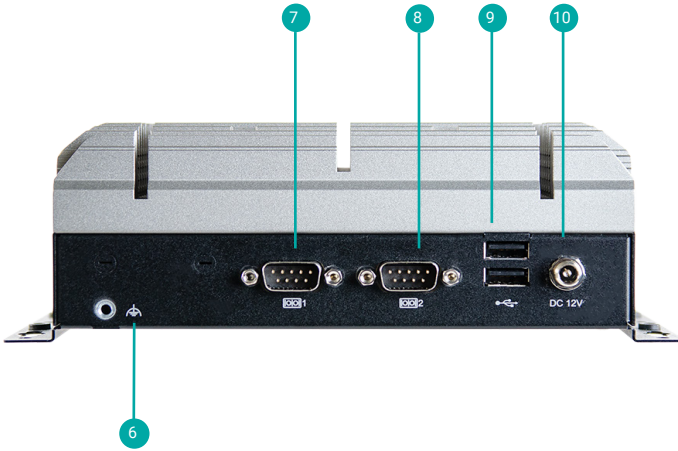

## Rear View - 3 storage

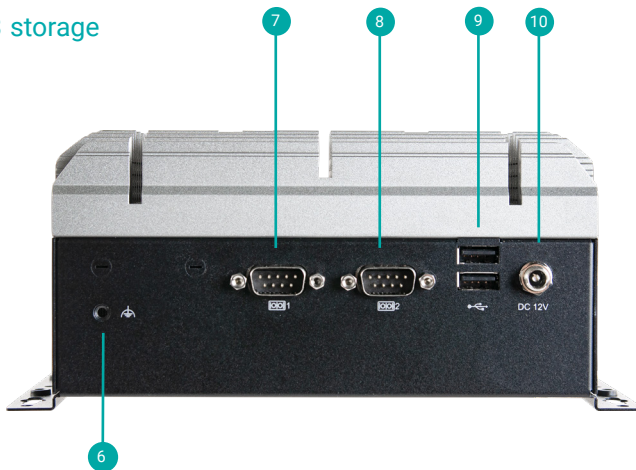

- 6 Grounding Hole
- 7 COM 1
- 8 COM 2
- 9 USB 2.0
- 10 DC-in

## Removing the Chassis Cover

Please observe the following guidelines and follow the instructions to open the system.

1. Make sure the system and all other peripheral devices connected to it have been powered off.
2. Disconnect all power cords and cables.

### Step 1:

**To remove the top cover** - The 8 screws on the top of the system are used to secure the cover to the chassis. Remove the screws and put them in a safe place for later use. And then lift up the cover to remove it.

**To remove the bottom cover** - The 2 screws on the bottom of the system are used to secure the cover to the chassis. Remove the screws and put them in a safe place for later use. And then tilt up the cover to remove it.

Top View



Bottom View



### Step 2:

Lift the cover to open the system.

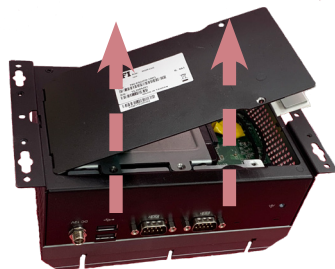
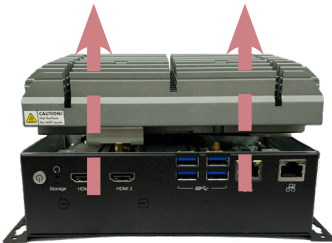

Step 3:

The board can be easily accessed after the chassis cover is removed.

Top View



Bottom View

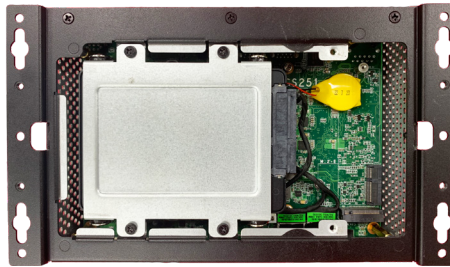

## Installing an M.2 Card

Please observe the following guidelines and follow the instructions to open the system.

1. Make sure the system and all other peripheral devices connected to it have been powered off.
2. Disconnect all power cords and cables.

### Step 1:

The 2 screws on the bottom of the system are used to secure the cover to the chassis. Remove the screws and put them in a safe place for later use.

Lift the cover to open the system. M.2 card slots can be easily accessed after the chassis cover is removed.

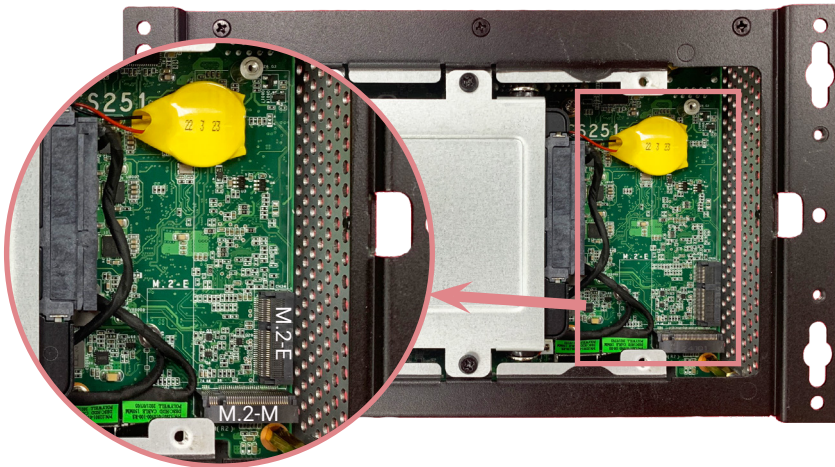

### Step 2:

Please follow the steps below to install the card into the socket.  
Insert the card into the socket at an angle while making sure the notch and key are perfectly aligned.

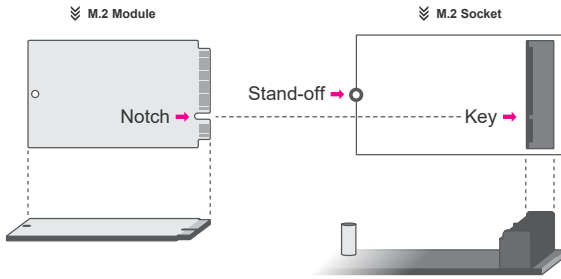

### Step 3:

Press the end of the card far from the socket down until against the stand-off.

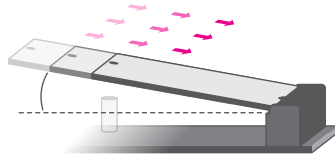

### Step 4:

Screw tight the card onto the stand-off with a screw driver and a stand-off screw until the gap between the card and the stand-off closes up. The card should be lying parallel to the board when it's correctly mounted.

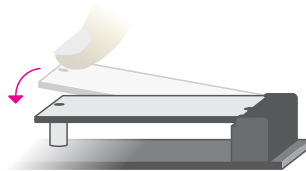

## Installing an Antenna

Before installing the antenna, please make sure that the following safety cautions are wellattended.

1. Make sure the PC and all other peripheral devices connected to it have been powered down.
2. Disconnect all power cords and cables.

### Step 1:

There are antenna holes reserved on the front and back side of the system and covered by 4 knockout tabs. Please remove the knockout tabs prior to installing an antenna.





### Step 2:

Use a flathead screwdriver and apply a little extra force to detach a knockout tab until it breaks off from the system.

Once the knockout tab is mostly detached, it will pretty quickly snap off, leaving you a nice hole for installing an antenna.

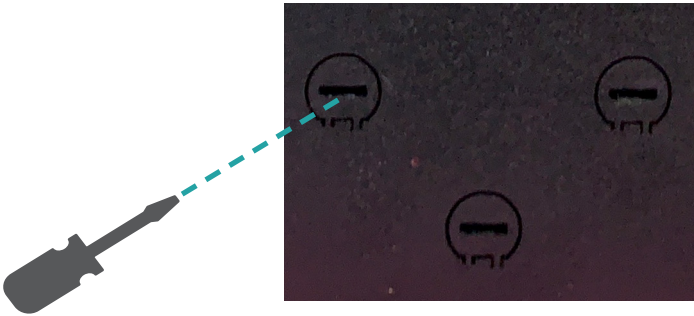

### Step 3:

Connect the internal cable to the board's antenna connector, screw the antenna connector through the antenna hole with washers and nuts, and screw on the antenna as illustrated below.

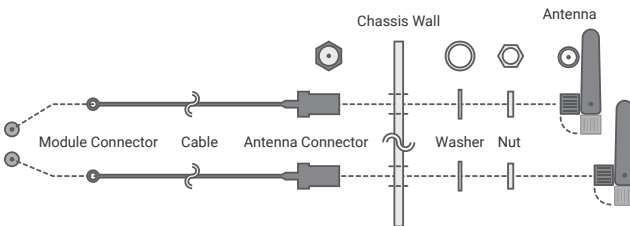

## Wall Mount

The wall mount kit containing two mounting brackets – purchased as optional items – can be attached to the bottom of the system for mounting onto desired locations, such as walls, stands, or shelves. Locate the mounting holes on the bottom of the system as shown in the photo. Screw on the two brackets onto the system with four screws as illustrated below.

ES220F-CS 1 storage as an example:

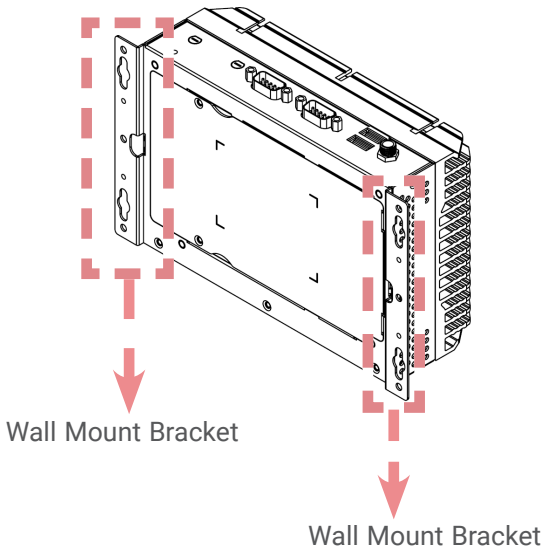

## VESA Mount

The VESA mount bracket has two sets of pre-drilled mounting holes – 75mm x 75mm, 100mm x 100mm – to adapt to mounting variants.

Mount the bracket onto the tapped holes on the back of a monitor, a stand or a wall rack.

If equipment installed on monitor by VESA mount, the weight for monitor should under 6.1kg

ES220F-CS 1 storage as an example:

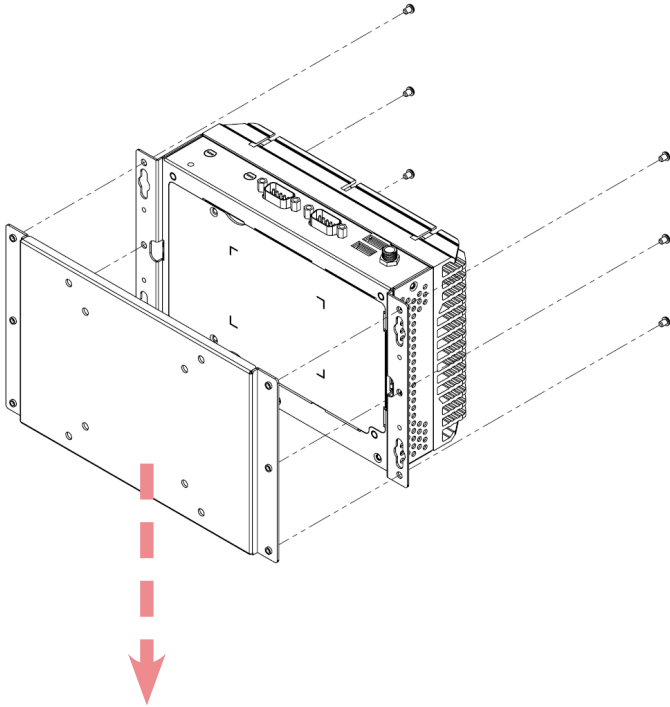

VESA Mount Bracket



DFI reserves the right to change the specifications at any time prior to the product's release. This QR may be based on the product's revision. For more documentation and drivers, please visit the download page at [www.dfi.com/downloadcenter](http://www.dfi.com/downloadcenter), or via the QR codes to the right.

