

W10MG3S-GSH2

10.1" ARM A78 + A55 G-WIN GS-Series Full IP65 PCAP Panel PC



KEY FEATURES

- 10.1" 1280 x 800 with PCAP touchscreen
- ARM 2 x A78 2.0GHz + 4 x A55 2.0GHz
- Fanless cooling system and Ultralow power consumption
- Full IP65
- Onboard 32GB eMMC
- Onboard LPDDR4 4GB
- 1 x LAN, 1 x RS232, 1 x USB, 1 x USB Type-C, 1 x Micro SD



SPECIFICATIONS

Display	
Resolution	1280x800
Contrast Ratio	800:1
View Angles	85,85,85,85
Touch / Glass	Projected Capacitive Multi Touch Screen Protection Glass (Optional)
Size	10.1 inches
Panel Brightness	350.0 nits
Active Area	216.96x135.6 mm
System Specification	
Processor	ARM 2 x A78 2.0GHz + 4 x A55 2.0GHz
Storage	Onboard 32 GB
Memory	4GB LPDDR4
Operating System	Android 13 Linux Yocto 5.10.104 with QT 5.15 (Optional) Linux Ubuntu 22.04 (Optional)
Environment	
Operating Humidity	10% to 95% RH, Non-Condensing
Storage Temperature	-30°C to 60°C
Vibration	MIL-STD-810H Method 514.8 Procedure I
Operating Temperature	-15°C to 55°C
Shock	MIL-STD-810H Method 516.8 Procedure I
IP rating	IP65
Certification	
Certification	CE, FCC
IO Ports	
USB Port	1 X USB 2.0 (M12 type) 1 X USB Type-C
SD Card Slot	1 x Micro SD card slot
LAN	1 x LAN 10/100/1000 Mbps (M12 type)
Serial Port	1 x RS232 (M12 type)(Optional 422/485)
Audio	1 x Speaker
Mechanical	
Dimension	263.28 x 172 x 40.2 mm
Enclosure	Aluminum
Mounting	Panel Mount VESA Mount
Cooling System	Fanless Design
Power	
Power Rating	12V DC (M12 type)
Accessory	
Accessory	Quick Start Guide (Hardcopy)

M12 Power Cable
M12 Serial Interface Cable
M12 USB/ LAN Cable
I/O Protective Cap x 3

DIMENSIONS UNIT:MM

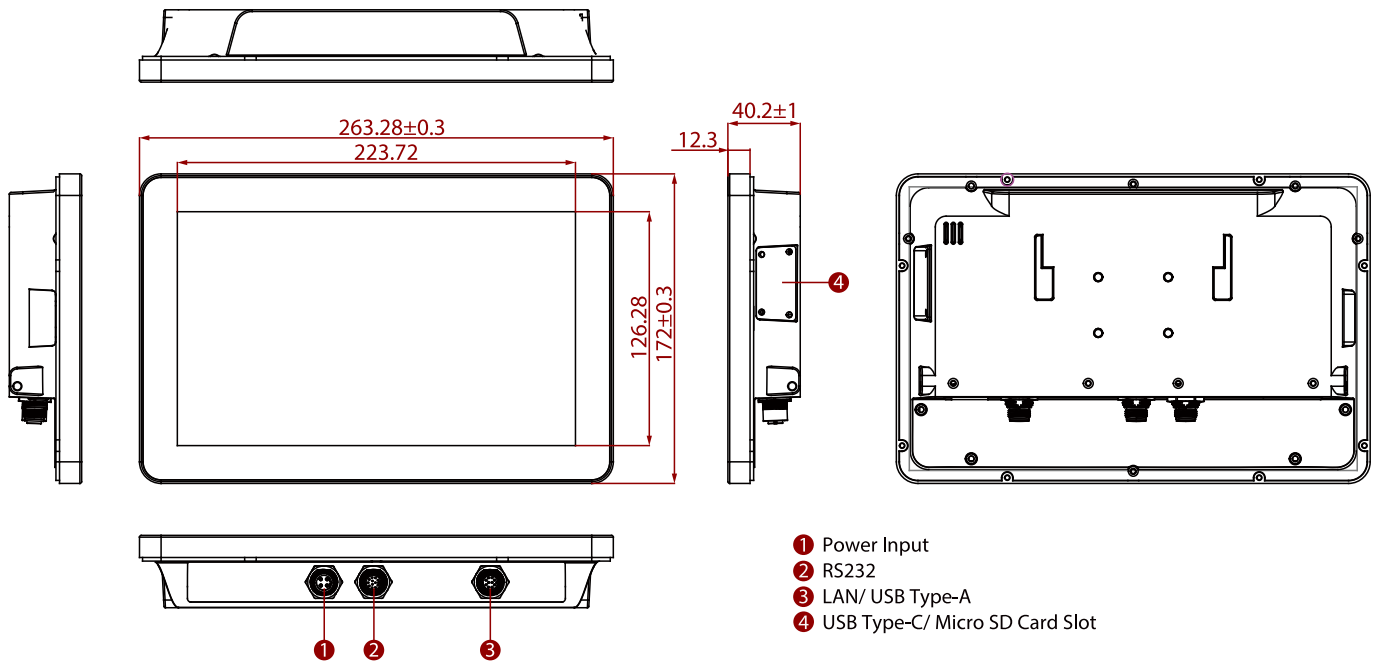

NOTE

- 1.This is a simplified drawing and some components are not marked in detail.
- 2.Please contact our sales representative if you need further product information.
- 3.All specifications are subject to change without prior notice.
- 4.The product shown in this datasheet is a standard model.For diagrams that contain customized or optional I/ O, please contact the Winmate Sales Team for more information.