

EL-Series HMI

Freescale® Cortex® A9 i.MX6 Dual Core, 1 GHz
Android 6.0



Model No. W04FA3S-ELT1
W05FA3S-ELT1
W07FA3S-ELT1
W10FA3S-ELH2
W15FA3S-ELA4

User Manual

Contents

Preface	3
About This User Manual	7
Chapter 1: Introduction	8
1.1 Introduction	9
1.2 Product Features.....	9
1.3 Package Contents.....	9
1.4 Description of Parts.....	10
Chapter 2: Getting Started	15
2.1 Powering On	16
2.2 Connector Description and Pin Assignments.....	17
Chapter 3: Mounting	19
3.1 Cable Mounting Considerations	20
3.2 Safety Precautions	20
3.3 Mounting Guide.....	20
Chapter 4: Operating the Device	25
4.1 Operating System	26
4.2 Multi-Touch	26
4.3 System Settings	27
4.4 Ethernet	29
4.5 Winmate® Home Manager (WHM).....	32
Chapter 5: Software Installation	37
5.1 Android Debug Bridge (ADB) Driver Installation	38
5.2 Installing Android Debug Bridge (ADB)	46
5.3 Downloading Image Tool.....	47
5.4 OTA Update Guide.....	47
5.5 OS Image Update Guide	51
Chapter 6: Technical Support	52
6.1 Introduction	53
6.2 Problem Report Form.....	- 53 -
Appendix A: Product Specifications	54

Preface

Copyright Notice

No part of this document may be reproduced, copied, translated, or transmitted in any form or by any means, electronic or mechanical, for any purpose, without the prior written permission of the original manufacturer.

Trademark Acknowledgement

Brand and product names are trademarks or registered trademarks of their respective owners.

Disclaimer

We reserve the right to make changes, without notice, to any product, including circuits and/or software described or contained in this manual in order to improve design and/or performance. We assume no responsibility or liability for the use of the described product(s) conveys no license or title under any patent, copyright, or masks work rights to these products, and make no representations or warranties that these products are free from patent, copyright, or mask work right infringement, unless otherwise specified. Applications that are described in this manual are for illustration purposes only. We make no representation or guarantee that such application will be suitable for the specified use without further testing or modification.

Warranty

Our warranty guarantees that each of its products will be free from material and workmanship defects for a period of one year from the invoice date. If the customer discovers a defect, we will, at his/her option, repair or replace the defective product at no charge to the customer, provide it is returned during the warranty period of one year, with transportation charges prepaid. The returned product must be properly packaged in its original packaging to obtain warranty service. If the serial number and the product shipping data differ by over 30 days, the in-warranty service will be made according to the shipping date. In the serial numbers the third and fourth two digits give the year of manufacture, and the fifth digit means the month (e. g., with A for October, B for November and C for December).

For example, the serial number 1W18Axxxxxxx means October of year 2018.

Customer Service

We provide a service guide for any problem by the following steps: First, visit the website of our distributor to find the update information about the product. Second, contact with your distributor, sales representative, or our customer service center for technical support if you need additional assistance.

You may need the following information ready before you call:

- Product serial number
- Software (OS, version, application software, etc.)
- Description of complete problem
- The exact wording of any error messages

In addition, free technical support is available from our engineers every business day. We are always ready to give advice on application requirements or specific information on the installation and operation of any of our products.

Advisory Conventions

Four types of advisories are used throughout the user manual to provide helpful information or to alert you to the potential for hardware damage or personal injury. These are Notes, Important, Cautions, and Warnings. The following is an example of each type of advisory.



Note:

A note is used to emphasize helpful information



Important:

An important note indicates information that is important for you to know.



Caution/ Attention

A Caution alert indicates potential damage to hardware and explains how to avoid the potential problem.

Une alerte d'attention indique un dommage possible à l'équipement et explique comment éviter le problème potentiel.



Warning!/ Avertissement!

An Electrical Shock Warning indicates the potential harm from electrical hazards and how to avoid the potential problem.

Un Avertissement de Choc Électrique indique le potentiel de chocs sur des emplacements électriques et comment éviter ces problèmes.



Alternating Current Mise à le terre !

The Protective Conductor Terminal (Earth Ground) symbol indicates the potential risk of serious electrical shock due to improper grounding.

Le symbole de Mise à Terre indique le risqué potentiel de choc électrique grave à la terre incorrecte.

Safety Information



Warning!/ Avertissement!

Always completely disconnect the power cord from your chassis whenever you work with the hardware. Do not make connections while the power is on. Sensitive electronic components can be damaged by sudden power surges. Only experienced electronics personnel should open the PC chassis.

Toujours débrancher le cordon d'alimentation du chassis lorsque vous travaillez sur celui-ci. Ne pas brancher de connexions lorsque l'alimentation est présente. Des composants électroniques sensibles peuvent être endommagés par des sauts d'alimentation. Seulement du personnel expérimenté devrait ouvrir ces chassis.



Caution/ Attention

Always ground yourself to remove any static charge before touching the CPU card. Modern electronic devices are very sensitive to static electric charges. As a safety precaution, use a grounding wrist strap at all times. Place all electronic components in a static-dissipative surface or static-shielded bag when they are not in the chassis. Toujours vérifier votre mise à la terre afin d'éliminer toute charge statique avant de toucher la carte CPU. Les équipements électroniques modernes sont très sensibles aux décharges d'électricité statique. Toujours utiliser un bracelet de mise à la terre comme précaution. Placer toutes les composantes électroniques sur une surface conçue pour dissiper les charge, ou dans un sac anti-statique lorsqu'elles ne sont pas dans le chassis.

For your safety carefully read all the safety instructions before using the device. Keep this user manual for future reference.

- Always disconnect this equipment from any AC outlet before cleaning. Do not use liquid or spray detergents for cleaning. Use a damp cloth.
- For pluggable equipment, the power outlet must be installed near the equipment and must be easily accessible.
- Keep this equipment away from humidity.
- Put this equipment on a reliable surface during installation. Dropping it or letting it fall could cause damage.
- The openings on the enclosure are for air convection and to protect the equipment from overheating.
- Do not cover the openings.
- Before connecting the equipment to the power outlet make sure the voltage of the power source is correct.
- Position the power cord so that people cannot step on it. Do not place anything over the power cord.
- If the equipment is not used for a long time, disconnect it from the power source to avoid damage by transient over-voltage.
- Never pour any liquid into an opening. This could cause fire or electrical shock.
- Never open the equipment. For safety reasons, only qualified service personnel should open the equipment.
- All cautions and warnings on the equipment should be noted.

***Let service personnel to check the equipment in case any of the following problems appear:**

- The power cord or plug is damaged.
- Liquid has penetrated into the equipment.
- The equipment has been exposed to moisture.
- The equipment does not work well or you cannot get it to work according to the user manual.
- The equipment has been dropped and damaged.
- The equipment has obvious signs of breakage.
- Do not leave this equipment in an uncontrolled environment where the storage temperature is below -20°C (-4°F) or above 60°C (140°F). It may damage the equipment.



Caution/Attention

Use the recommended mounting apparatus to avoid risk of injury.
Utiliser l'appareil de fixation recommandé pour éliminer le risque de blessure.



Warning!/ Avertissement!

Only use the connection cords that come with the product. When in doubt, please contact the manufacturer.

Utiliser seulement les cordons d'alimentation fournis avec le produit. Si vous doutez de leur provenance, contactez le fabricant.



Warning!/ Avertissement!

Always ground yourself against electrostatic damage to the device.

Toujours vérifier votre mise à la terre afin que l'équipement ne se décharge pas sur vous.

- Cover workstations with approved anti-static material. Use a wrist strap connected to a work surface and properly grounded tools and equipment.
- Use anti-static mats, heel straps, or air ionizer for added protection.

- Avoid contact with pins, leads, or circuitry.
- Turn off power and input signals before inserting and removing connectors or test equipment.
- Keep the work area free of non-conductive materials, such as ordinary plastic assembly aids and Styrofoam.
- Use filed service tools, such as cutters, screwdrivers, and vacuum cleaners that are conductive.
- Always put drivers and PCB's component side on anti-static foam.

Important Information

Federal Communications Commission Radio Frequency Interface Statement



This device complies with part 15 FCC rules.

Operation is subject to the following two conditions:

- This device may not cause harmful interference.
- This device must accept any interference received including interference that may cause undesired operation.

This equipment has been tested and found to comply with the limits for a class "B" digital device, pursuant to part 15 of the FCC rules. These limits are designed to provide reasonable protection against harmful interference when the equipment is operated in a commercial environment. This equipment generates, uses, and can radiate radio frequency energy and, if not installed and used in accordance with the instruction manual, may cause harmful interference to radio communications. Operation of this equipment in a residential area is likely to cause harmful interference in which case the user will be required to correct the interference at his own expense.

EC Declaration of Conformity



This equipment is in conformity with the requirement of the following EU legislations and harmonized standards. Product also complies with the Council directions.

Electromagnetic Compatibility Directive (2014/30/EU)

- EN55024: 2010 EN 55022: 2010 Class B
 - IEC61000-4-2: 2009
 - IEC61000-4-3: 2006+A1: 2007+A2: 2010
 - IEC61000-4-4: 2012
 - IEC61000-4-5: 2014
 - IEC61000-4-6: 2013
 - IEC61000-4-8: 2010
 - IEC61000-4-11: 2004
- EN55022: 2010/AC:2011
- EN61000-3-2:2014
- EN61000-3-3:2013

Low Voltage Directive (2014/35/EU)

- EN 60950-1:2006/A11:2009/A1:2010/A12:2011/ A2:2013

About This User Manual

This User Manual provides information about using the Winmate® EL-Series HMI. This User Manual applies to the EL-Series HMI – W04FA3S-ELT1, W07FA3S-ELT1, W10FA3S-ELH2, and W15FA3S-ELA2.

The documentation set for the EL-Series HMI with Freescale® Cortex® A9 i.MX6 Dual Core provides information for specific user needs, and includes:

- **EL-Series HMI User Manual** – contains detailed description on how to use the HMI device, its components and features.
- **EL-Series HMI Quick Start Guide** - describes how to get the HMI up and running.



Note:

Some pictures in this guide are samples and can differ from actual product.

Document Revision History

Version	Date	Note
1.0	25-Jul-2018	Initial document release
1.1	20-Feb-2019	Add 5.6" HMI device.
1.2	20-Mar-2019	Revise specifications
1.3	10-Sep-2019	Revise cutout dimensions

Chapter 1: Introduction

This chapter gives you product overview, describes features and hardware specification. You will find all accessories that come with the HMI in the packing list. Mechanical dimensions and drawings included in this chapter.

1.1 Introduction

Congratulations on purchasing Winmate® EL-Series HMI. Winmate continues developing new generation of Human Machine Interfaces for Industry 4.0 and Internet of Things (IoT). Our EL-Series HMI runs on Android 6.0 operating system that allows installing the latest applications (APPs). There is one USB 2.0 onboard to connect mouse or keyboard, Micro USB OTG for system updates. System memory LPDDR3 of 1 GB ensures stable operation of applications.

With mounting clips for panel mounting there is no need to drill holes in a fixture. This saves you the time for mounting and guarantee aesthetic look of the wall after the unit gets removed.

1.2 Product Features

Winmate® EL-Series HMI features:

- 4.3/ 5.6/ 7/ 10.1/ 15.6-inch widescreen panel
- Freescale® Cortex® A9 i.MX6 Dual Core, 1 GHz
- Android 6.0 operating system
- Projected Capacitive (P-CAP) Multi-Touch
- Fanless cooling system and ultra-low power consumption
- Front IP65 water and dust proof, rear IP22
- Mounting clips for quick Installation
- Light design for machine automation, smart factory and IoT applications

1.3 Package Contents

Carefully remove the box and unpack your device. Package content may vary based on your order. Please check if all the items listed below are inside your package. If any of these items are missing or damaged contact us immediately.

Standard factory shipment list:

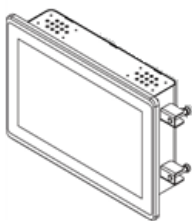

- **HMI Device**
Varies by product specifications



- **Quick Start Guide (Hardcopy)**
Part No.91521111135



- **Driver CD & User Manual (Digital Copy)**
Varies by product specifications

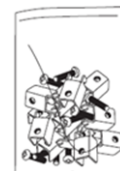

- **Mounting Clip & Screw**
4.3" HMI - 4 pcs, 5.6" HMI - 6 pcs,
7" - 7 pcs, 10.1" HMI - 8 pcs, 15.6"
HMI - 10 pcs
Part No. 82111E240400

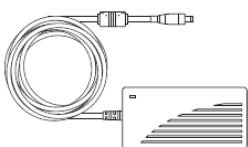

- **AC Adapter (12V/ 50W)**
Part No. 922D050W12VA

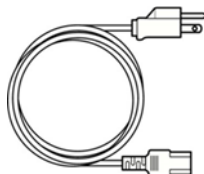

- **Power Cord**
Varies by country



- **3 pin Terminal Block**
Part No. 94J602G020K0

1.4 Description of Parts

This section describes appearance, connectors' layout and mechanical dimensions of EL-Series HMI. Notice that this is a simplified drawing and some components are not marked in detail. Please contact our sales representative if you need further product information.

EL-Series HMI 4.3"

Unit: mm

Dimensions : 121.5 x 82.05 x 42.2

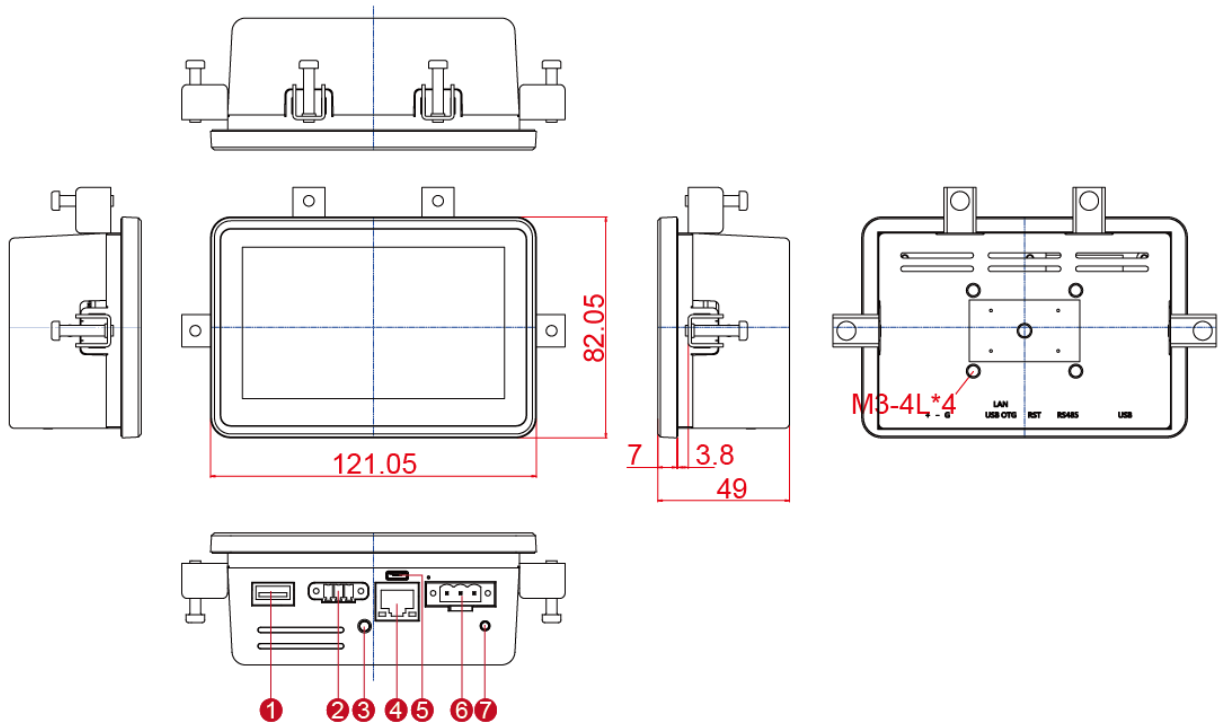

No	Description	No	Description
1	USB 2.0	5	USB OTG
2	RS485	6	Power Terminal Block
3	Reset Button	7	LED Indicator
4	RJ45/ LAN		

EL-Series HMI 5.6"

Unit: mm

Dimensions : 158.7 x 116.3 x 51

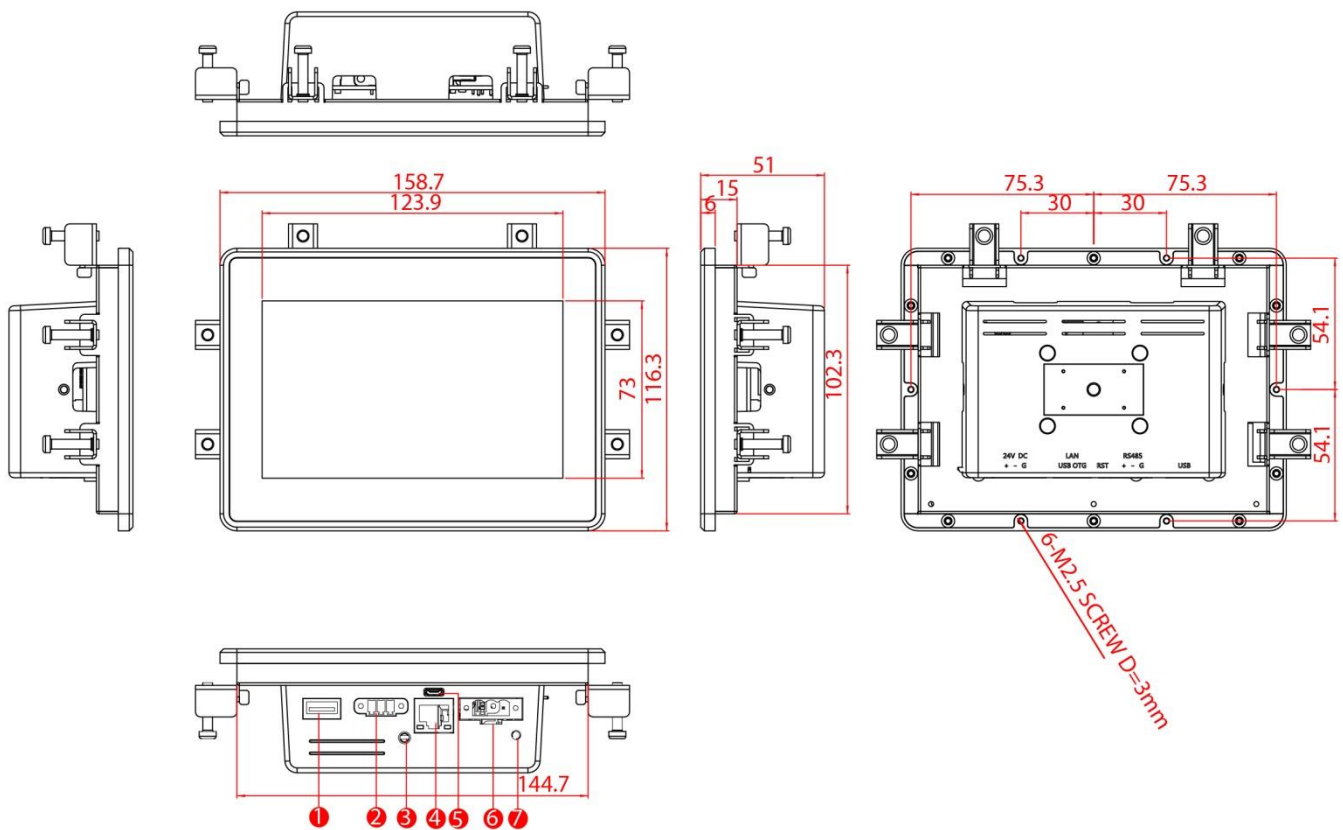

No	Description	No	Description
①	USB 2.0	⑤	USB OTG
②	RS485	⑥	Power Terminal Block
③	Reset Button	⑦	LED Indicator
④	RJ45/ LAN		

EL-Series HMI 7"

Unit: mm
 Dimensions : 184.94 x 127.7 x 44.9

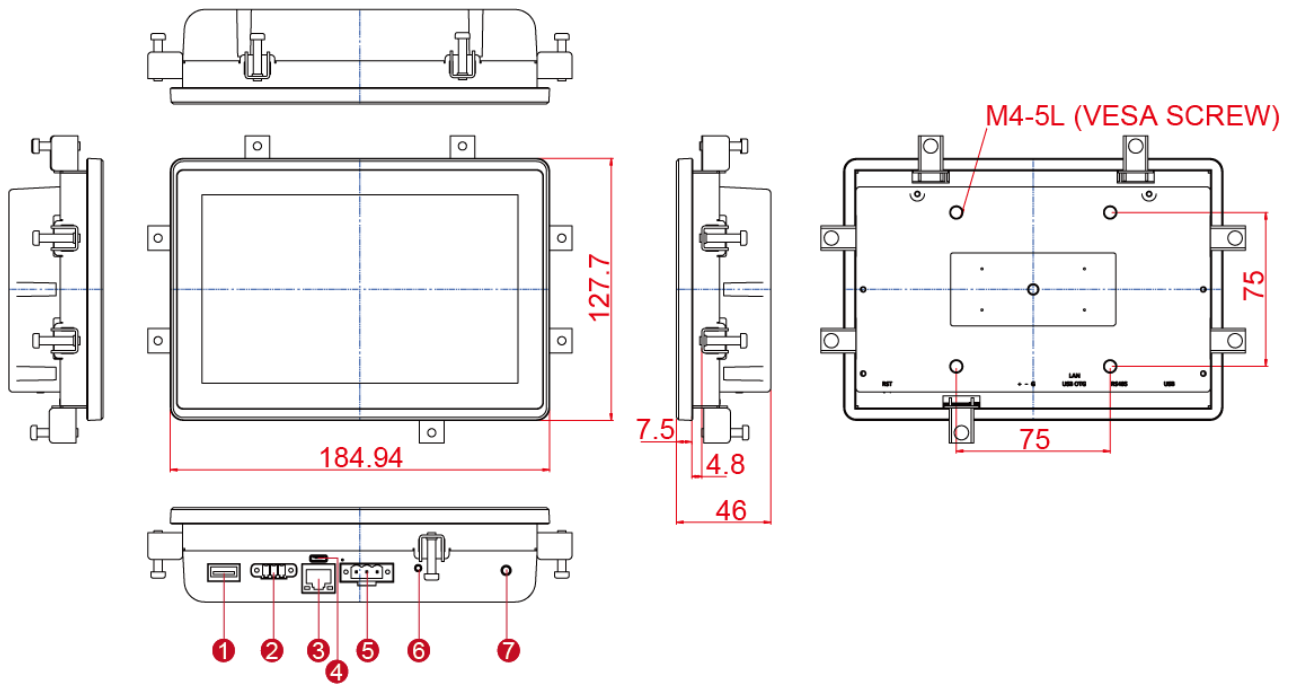

No	Description	No	Description
①	USB 2.0	⑤	Power Terminal Block
②	RS485	⑥	LED Indicator
③	RJ45/ LAN	⑦	Reset Button
④	USB OTG		

EL-Series HMI 10.1"

Unit: mm

Dimensions : 267.42 x 182.14 x 57.6

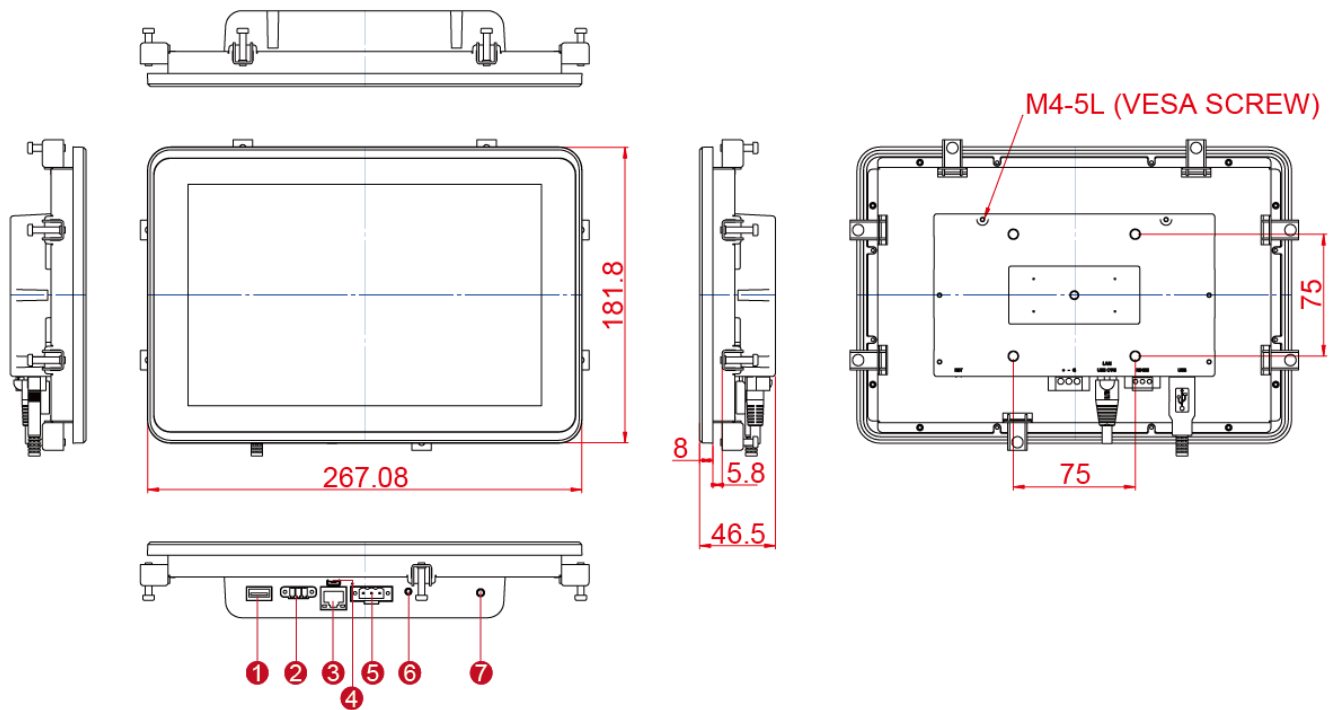

No	Description	No	Description
①	USB 2.0	⑤	Power Terminal Block
②	RS485	⑥	LED Indicator
③	RJ45/ LAN	⑦	Reset Button
④	USB OTG		

EL-Series HMI 15.6”

Unit: mm
 Dimensions : 387.6 x 257.7 x 52.5

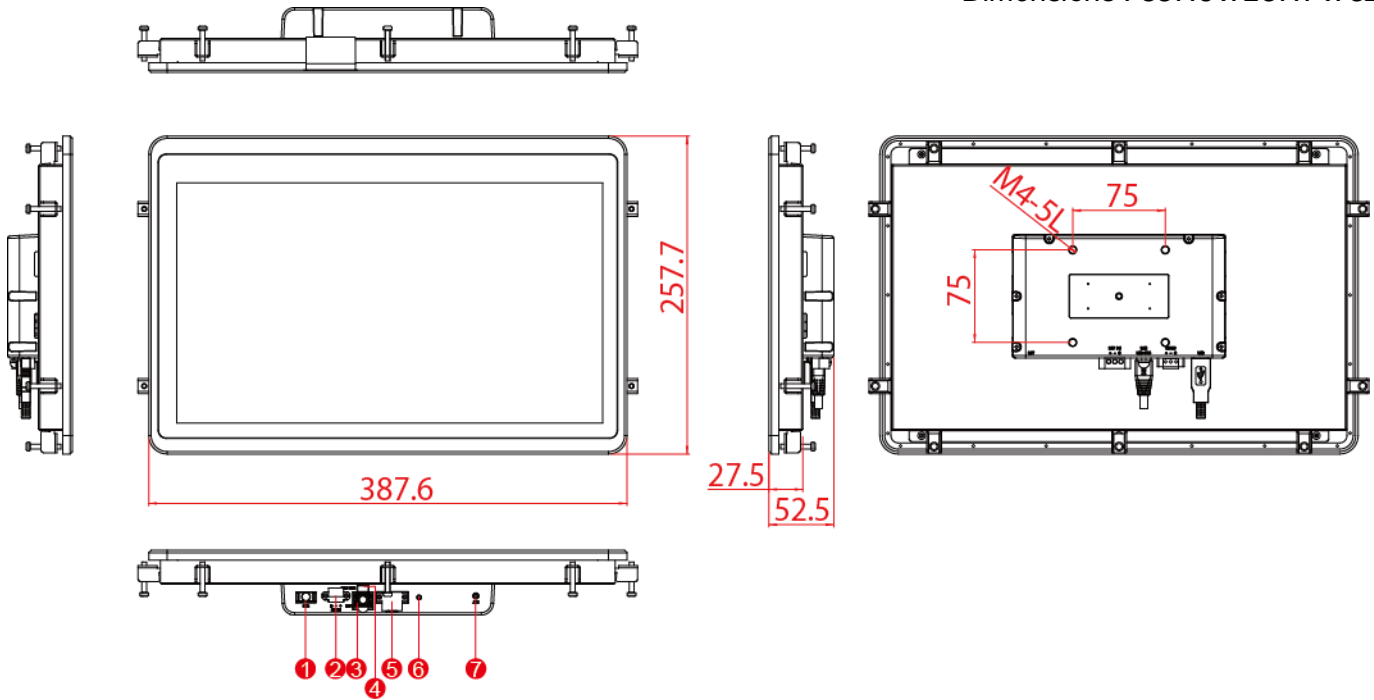

No	Description	No	Description
①	USB 2.0	⑤	Power Terminal Block
②	RS485	⑥	LED Indicator
③	RJ45/ LAN	⑦	Reset Button
④	USB OTG		

Chapter 2: Getting Started

This chapter tells you important information on power supply, adapter and precautions tips. Pay attention to power considerations.



2.1 Powering On

2.1.1 AC Adapter Components

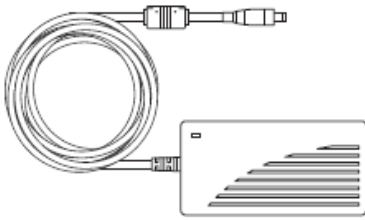

- AC Adapter



- Power Cord

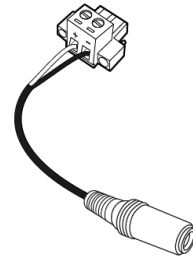

- 2 Pin Terminal Block to DC Jack

Safety Precautions:

- Do not use the adapter in a high moisture environment
- Never touch the adapter with wet hands or foot
- Allow adequate ventilation around adapter while using
- Do not cover the adapter with paper or other objects that will reduce cooling
- Do not use the adapter while it is inside a carrying case
- Do not use the adapter if the cord is damaged
- There are NO serviceable parts inside
- Replace the unit if it is damaged or exposed to excess moisture

While using the AC Adapter always:

- Plug-in the power cord to easy accessible AC outlet
- Plug-in the AC adapter to a grounded outlet



Alternating Current/ Mise à la terre !

This product must be grounded. Use only a grounded AC outlet. Install the additional PE ground wire if the local installation regulations require it.

**If you do not use a grounded outlet while using the device, you may notice an electrical tingling sensation when the palms of your hands touch the device.*

[FR]Ce produit doit être mis à la terre. Utiliser seulement un cordon d'alimentation avec mise à la terre. Si les règlements locaux le requiert, installer des câbles de mise à la terre supplémentaires.

**Si vous n'utilisez pas une prise d'alimentation avec mise à la terre, vous pourriez remarquer une sensation de picotement électrique quand la paume de vos mains touche à l'appareil.*

2.1.2 Power Considerations

The HMI device operates on external DC power. Use the AC adapter included in the package.



Caution/ Attention

Use only the AC adapter included in your package

(Rating: Output 12 V/ 6.6A). Using other AC adapters may damage the device.

Utiliser seulement le convertisseur AC inclu avec votre appareil (Puissance: Sortie 12 V/ 6.6A). Utiliser d'autres convertisseurs pourraient endommager l'appareil.

2.1.3 Connecting the Power

Installation Instruction:

1. Connect a 3-pin terminal block to the HMI connector.
2. Connect the other side of the terminal block to the AC adapter.
3. Connect the AC adapter to the power cord.
4. Plug in the power cord to a working AC wall outlet. The device will boot automatically.

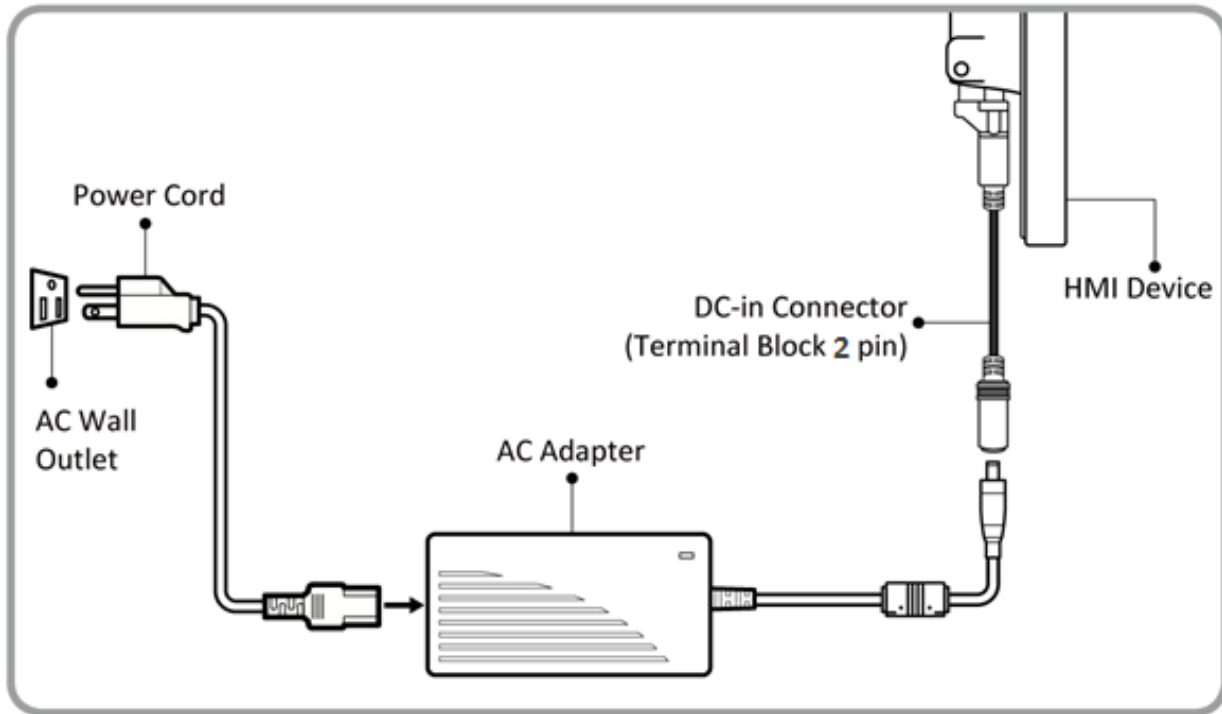

Note:

Based on the model, terminal block connector may be located either on the bottom or on the rear side of the HMI device.



Note:

Power cords vary in appearance by region and country.

2.2 Connector Description and Pin Assignments

2.2.1 Power Input Connector

The DC power source input of the panel PC is a 2 pin terminal block connector that supports 12-24V DC power input, maximum current 3.3A.

Pin assignment and connector description of terminal block connector

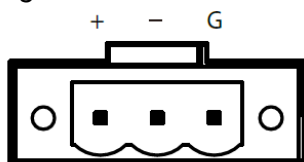

Minimum Voltage 9V
Maximum Voltage 24V
Maximum Current 3.3A

2.2.2 Serial Port Connector

The HMI device has one RS-485 serial port connector to connect your device to external devices.

Pin assignment and connector description of serial port connector

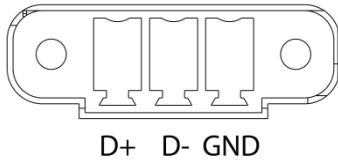

Pin No	Signal Name
1	D+
2	D-
3	GND

2.2.3 Ethernet Connector

The HMI device supports one RJ45 10/100/1000 Mbps Ethernet interface for connecting to the internet.

Pin assignment and connector description of RJ45 connector

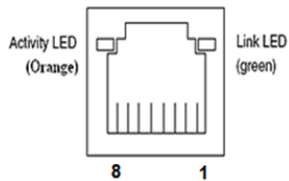

Pin No	Signal Name	Pin No	Signal Name
1	TX1+	2	TX1-
3	TX2+	4	TX2-
5	TX3+	6	TX3-
7	TX4+	8	TX4-

2.2.4 USB 2.0 Connector

Use USB A Type (USB 2.0) connector to connect your device to other USB 2.0 compatible devices.

Pin assignment and connector description of USB 2.0 connector

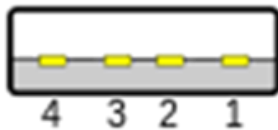

Pin No	Signal Name	Pin No	Signal Name
1	+5V	2	USB_D-
3	USB_D+	4	GND

2.2.5 USB OTG Connector

Use USB OTG connector to connect the panel PC to other USB On-The-Go compliant devices such as flash drives, digital cameras, mice or keyboards. Use USB OTG cable to install software on the panel PC.

Pin assignment and connector description of USB OTG connector

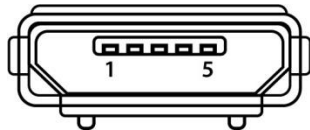

Pin No	Signal Name	Pin No	Signal Name
1	+5V	2	USB_OTG_D-
3	USB_OTG_D+	4	USB_OTG_ID
5	GND		

Refer to [Ch.5](#) of this user manual for more details on how to install software

Chapter 3: Mounting

This chapter provides mounting guide for all available mounting options. Pay attention to cautions and warning to avoid any damages.

3.1 Cable Mounting Considerations

For a nice look and safe installation, make sure cables are neatly hidden behind the HMI device. Refer to [Chapter 2, section 2.1](#) for the cable installation instruction.



Caution/ Attention

Observe all local installation requirements for connection cable type and protection level. Suivre tous les règlements locaux d'installations, de câblage et niveaux de protection.



Caution/ Attention

Turn off the device and disconnect other peripherals before installation. Éteindre l'appareil et débrancher tous les périphériques avant l'installation.



Alternating Current / Mise à la terre !

To prevent electrical shock, the Safety Ground location on the rear must be bonded to the local earth ground through a minimum 12 AWG wire as short as possible. Pour éviter les chocs électriques, l'emplacement de la prise terre à l'arrière doit être lié à terre locale, à travers un 12 AWG minimum et aussi court que possible.

3.2 Safety Precautions

Observe the following common safety precautions before installing any electronic device:

- Use separate, non-intersecting paths to route power and networking wires. If power wiring and device wiring paths must be crossed make sure the wires are perpendicular at the intersection point.
- Keep the wires separated according to the interface. Wires that share similar electrical characteristics must be bundled together.
- Do not bundle input wiring with output wiring. Keep them separate.

When necessary, it is strongly advised that you label wiring to all devices in the system.

3.3 Mounting Guide

EL-series HMI devices come with different mounting options suitable for most of the industrial and commercial applications. The main mounting approach is rear mount - very user-friendly in terms of installation. Refer to sub-sections below for more details.



Caution/ Attention

Follow mounting instructions and use recommended mounting hardware to avoid the risk of injury.

Suivez les instructions de montage et d'utilisation recommandé le matériel de montage pour éviter le risque de blessure.

3.3.1 Panel Mount

Panel mount solution is suitable for many applications where HMI should be embedded in the machine. With this mounting solution flat surface leave no bezel in the front. In addition to elegant design, rear mount solution is making the HMI unit easy to clean and maintain. The HMI device is secured to the fixture from the rear by using the mounting brackets included in the package.

Size	4.3"	5.6"	7"	10.1"	15.6"
Cutout dimension (W x D in mm)	109.6 x 71.2	145.7 x 103.3	174.08 x 116.9	244 x 159	371.6 x 223.5
Mounting Clips and Screws	4 pcs	6 pcs	7 pcs	7 pcs	10 pcs

Mounting Instruction

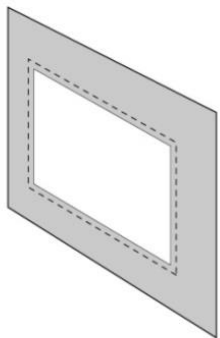
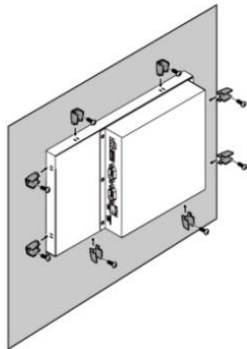
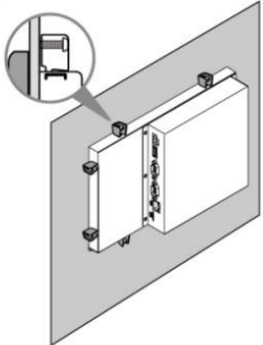
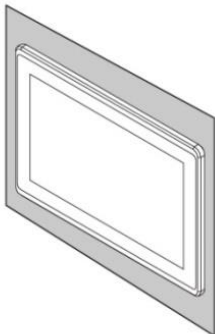
<p>1</p> 	<p>Prepare a cutout on a fixture according to the cutout dimensions.</p>
<p>2</p> 	<p>Select the mounting holes according to the wall thickness of the fixture and secure the mounting clips onto four sides of the HMI device.</p>
<p>3</p> 	<p>Secure the HMI to the fixture by screws.</p>
<p>4</p> 	<p>Connect power and other peripherals to the HMI unit.</p>

3.3.2 VESA Mount

VESA mount is a widely used mounting solution suitable for all kinds of industrial applications. Notice that only 7", 10.1", 15.6" HMI devices support VESA mounting.

Size	VESA Dimensions	Screw Hole Diameter
7", 10.1", 15.6"	75 x 75 mm	VESA M4 x 3 mm

Mounting Instruction

Use Philips M4x5 screws to fix the desk stand to VESA holes on the back cover of the device.

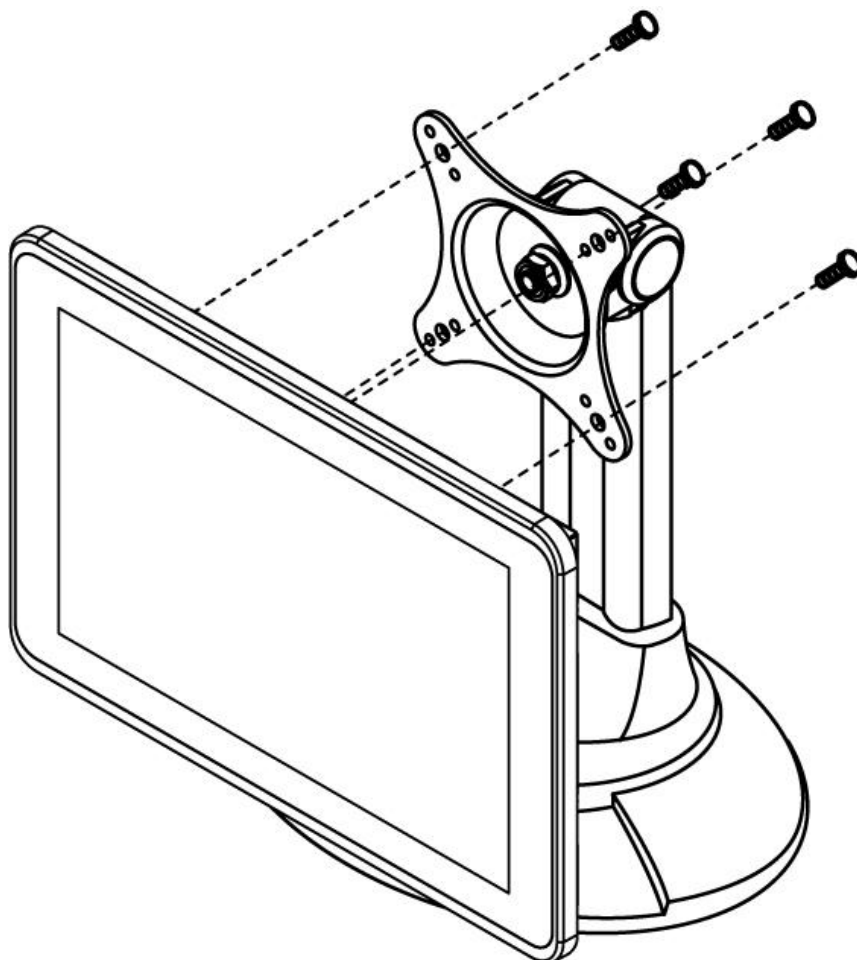

**The picture is for demonstration purposes only. VESA Mounting accessories are not supplied with the HMI device*

3.3.3 RAM Mount

RAM mount is a mounting solution suitable for in-vehicle device installation. Notice that only 4.3" and 5.6" HMI devices support RAM mounting. The pictures in this section are for demonstration purposes only. RAM mount accessories are not supplied with the HMI device.

RAM Base Dimensions: 38.1 x 30 mm
Screw: 4 x M5-0.8x10 mm Phillips screws

RAM Mount parts may be ordered individually through RAM Mount (www.rammount.com)

No Drill Solution

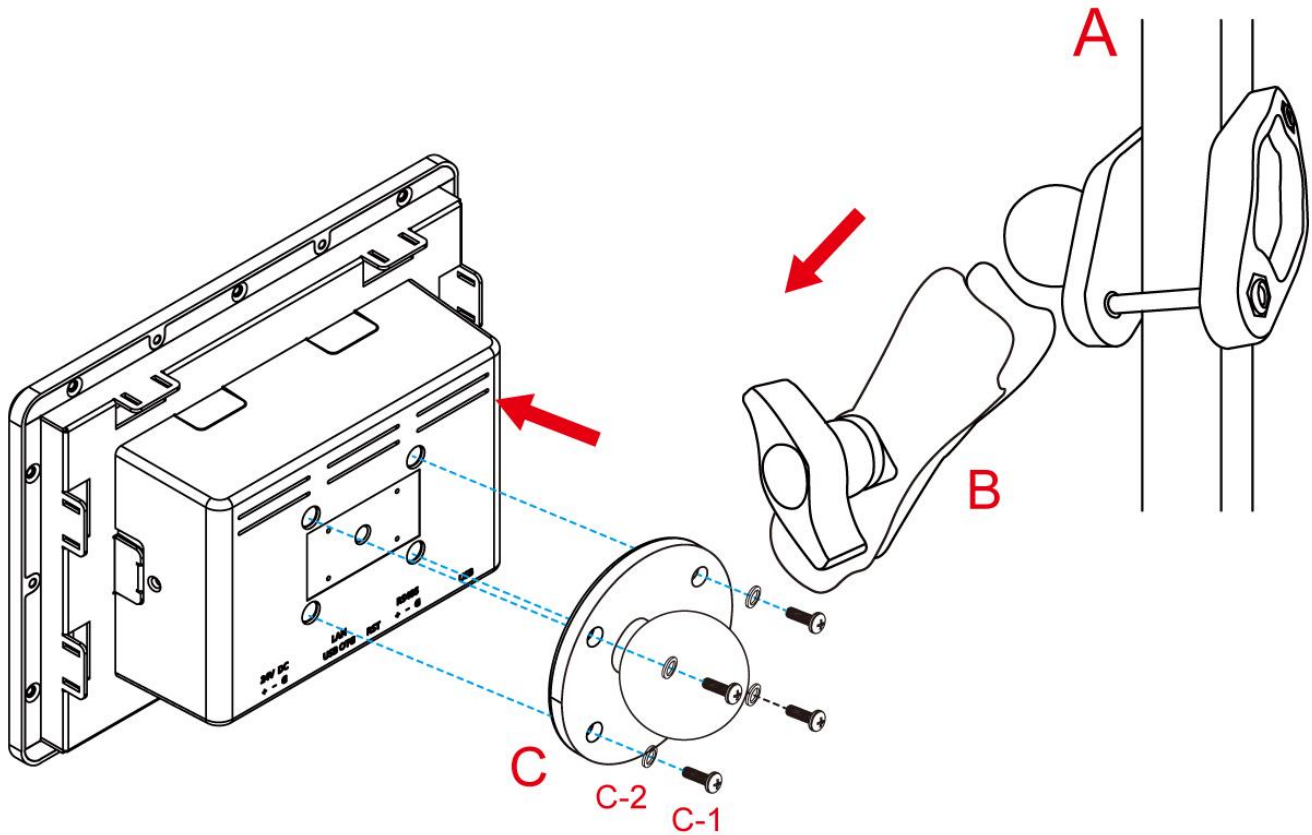

Drill Solution

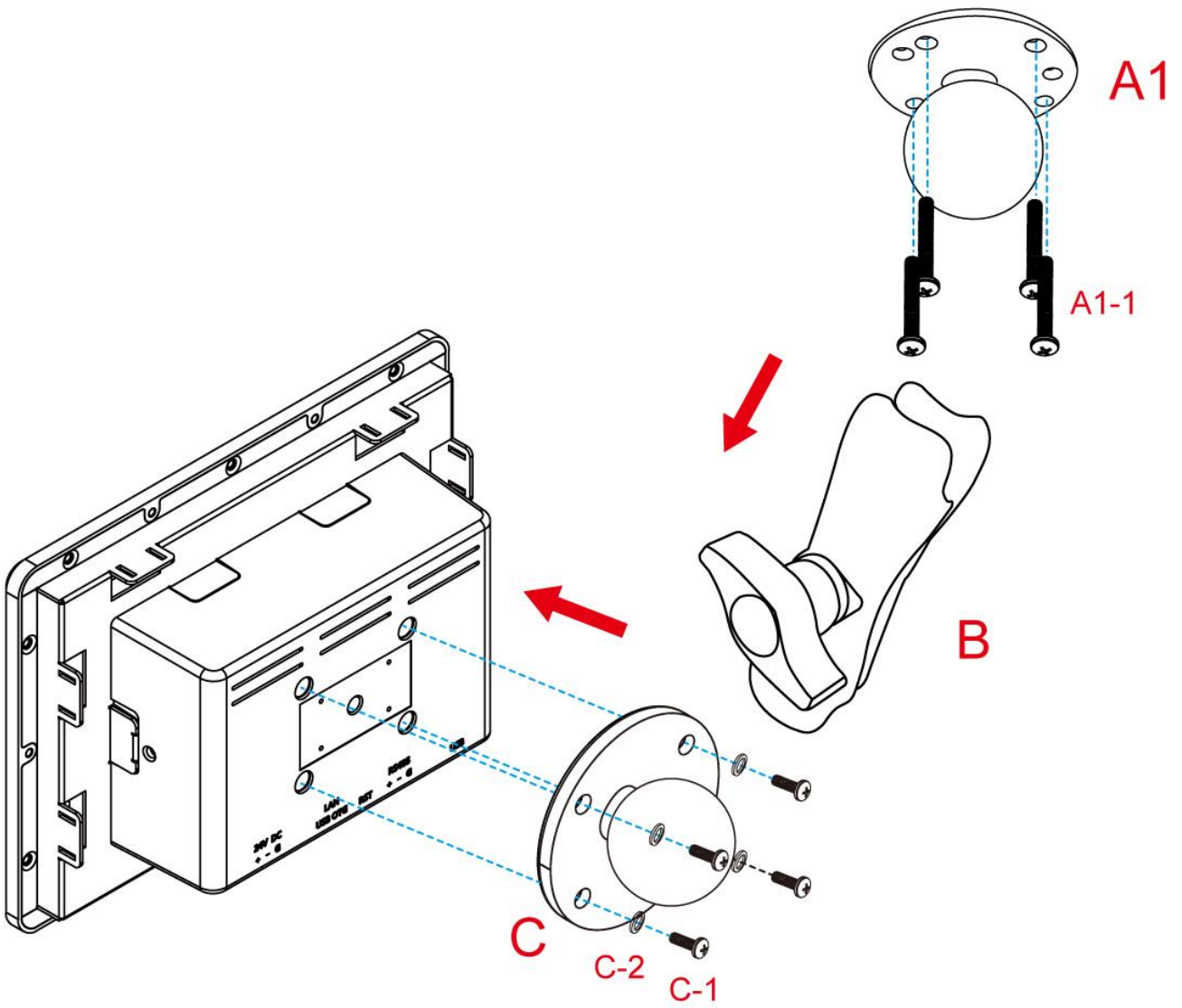

Chapter 4: Operating the Device

In this chapter you will find instructions on how to operate the HMI device.



4.1 Operating System

EL-series HMI supports Android 6.0.









Important:

The watchdog timer is set by default. The system will automatically reboot if it hangs after 30 seconds. If the app hangs, watchdog function will not be activated.

4.2 Multi-Touch

The touchpad supports the core gestures for Android.

Gesture	Action	Description
Touch		To select or activate something
Touch & Hold		Touch and hold an item on the screen by touching it and not lifting your finger until it respond
Touch, Hold & Drag		Touch and hold an item for a moment and then without lifting your finger, move your finger on the screen until you reach the target position. i.e. moving the apps around the home screen
Swipe or slide		Quickly move the finger across the surface of the screen. i.e. slide a lock screen to open the lock
Double-tap		Tap quickly twice on a webpage, screen, or App to zoom
Scale		Place two finger on the screen and pinching them together
Type		Touch where you want to type. A keyboard pops up that lets you type into the field.

*Reference from Android®

4.3 System Settings

This section explains how to adjust main system settings in Android 6.0.

4.3.1 Set up the Device



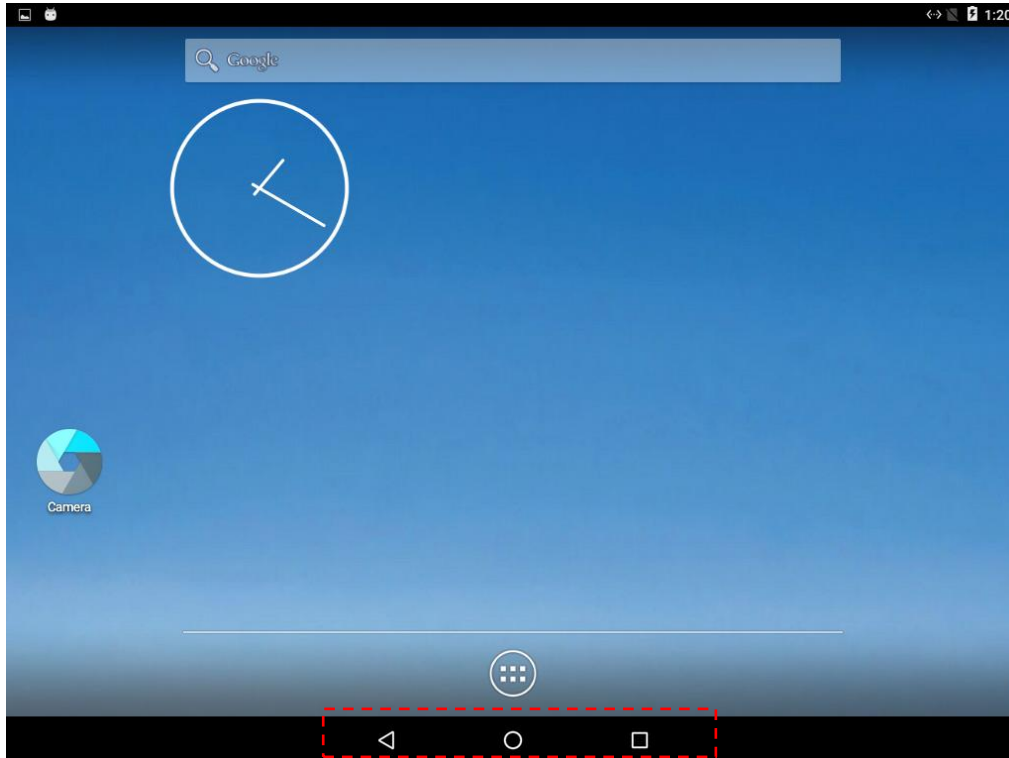

When you first turn on your HMI device, you'll see a **Welcome screen**. Choose the language you want and touch **Start** or the Start icon. When prompted, you can sign in with your Google Account or create one at that time. You can also choose to skip this step and create one later.

4.3.2 Home Screen

Your device runs on Android 6.0 Operation System (Default).



Navigation Buttons

	<p>Back</p> <p>Opens the previous screen you were working in, even if it was in a different app. Once you back up to the Home screen, you can't go back any further.</p>
	<p>Home</p> <p>Returns to the Home screen. To get suggestions based on the screen you're currently viewing, touch & hold this button.</p>
	<p>Overview</p> <p>Opens a list of thumbnail images of screens you've worked with recently. To open one, touch it. To remove a screen from the list, swipe it left or right or touch the X.</p>
	<p>Your apps</p> <p>To see all your apps, touch  in the Favorites tray on any Home screen. This is where you can see all your apps, including those that come with your phone or tablet and those you downloaded on Google Play. You can move app icons to any of your Home screens. The apps you've used most recently appear in the first row.</p>

Some apps hide these buttons temporarily, or fade them to small dots in the same position. To bring them back, touch the dots, touch the screen in the middle, or swipe up from the bottom.

Many screens in apps and Settings include a **menu**  icon at the top right of the screen. Touch it to explore additional options, including Help & feedback.

To add an app to a Home screen:

1. Go to the Home screen where you want to place the app.
2. Touch **All Apps** .
3. Swipe from left to right to find the app you want.
4. Touch & hold the app until the Home screen appears, slide it into place, and lift your finger.





To remove an app icon from the Home screen without removing it permanently from your device, touch & hold it, slide your finger toward the top of the screen, and drop the app over Remove in the top left.

4.3.3 Quick Settings

You can open your device's Settings app from the All Apps screen or from Quick Settings.

For example, to change notification sounds, and volume go to Settings  > Device > Sound to change the volume.

Use Quick Settings to easily change frequently used settings, like turning on Wi-Fi. To open Quick Settings, swipe down from the top of the screen with two fingers. To change a setting, just touch the icon:

- **Display brightness:** Slide  to lower or increase the brightness of your screen.
- **Wi-Fi network:** Turn Wi-Fi  on or off or open the Wi-Fi settings menu.
- **Bluetooth settings:** Turn Bluetooth  on or off or open the Bluetooth settings menu.
- **Auto-rotate:** Lock your device's orientation  in portrait or landscape mode.

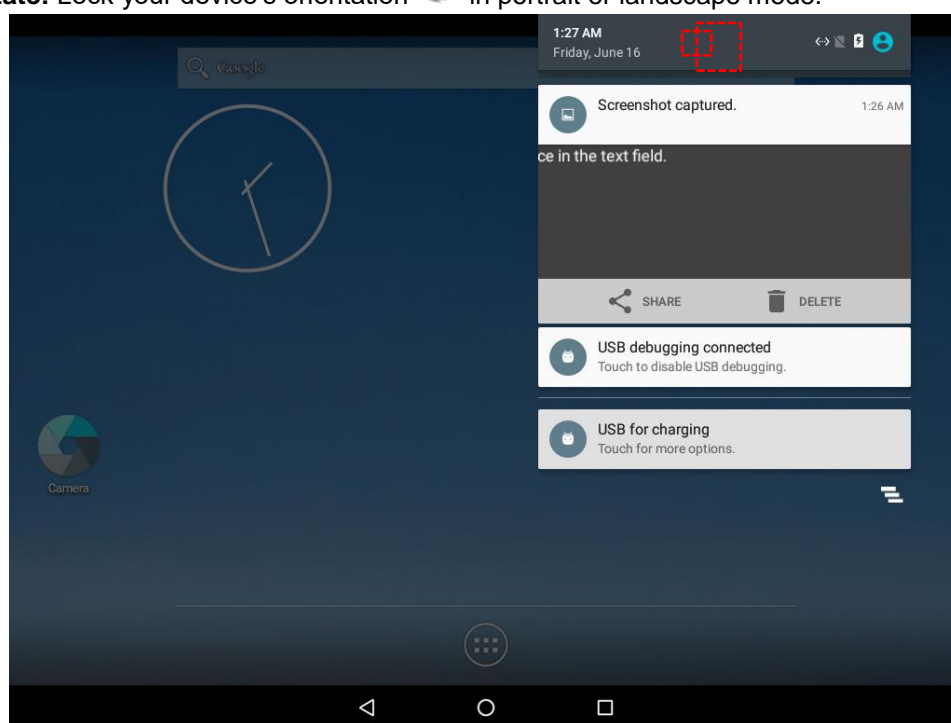

Open the main Settings menu by touching **Settings**  at the top right.

4.4 Ethernet

1. Connect Ethernet Cable to the HMI.
2. Touch **All APPS** icon, and the open **Ethernet** application.

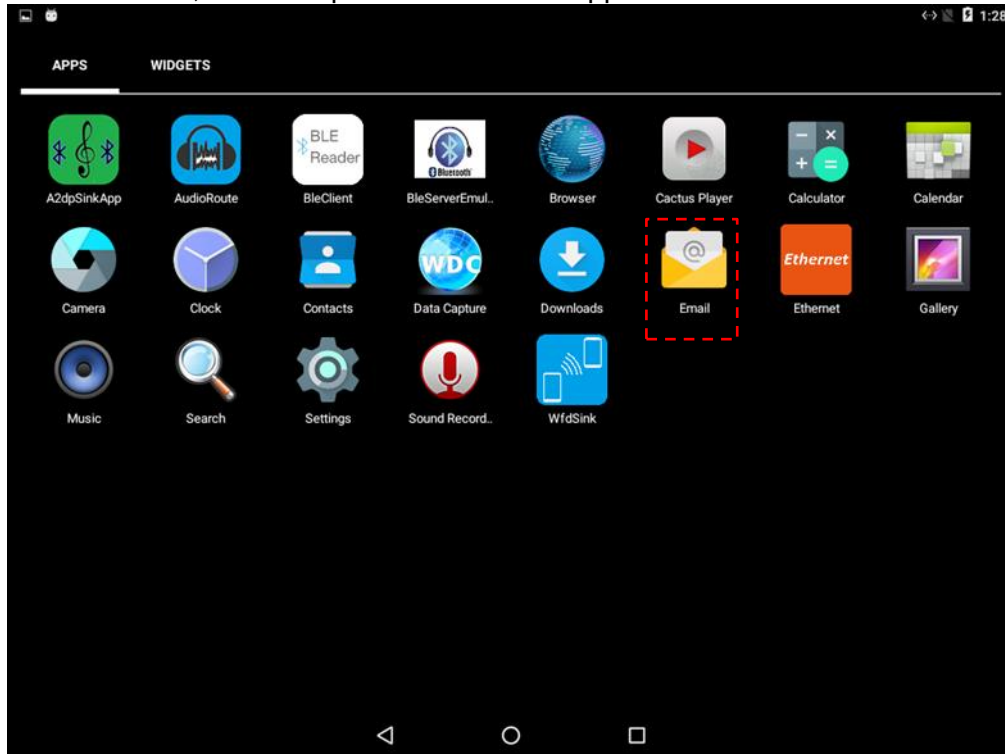

3. Ethernet APP main menu appears

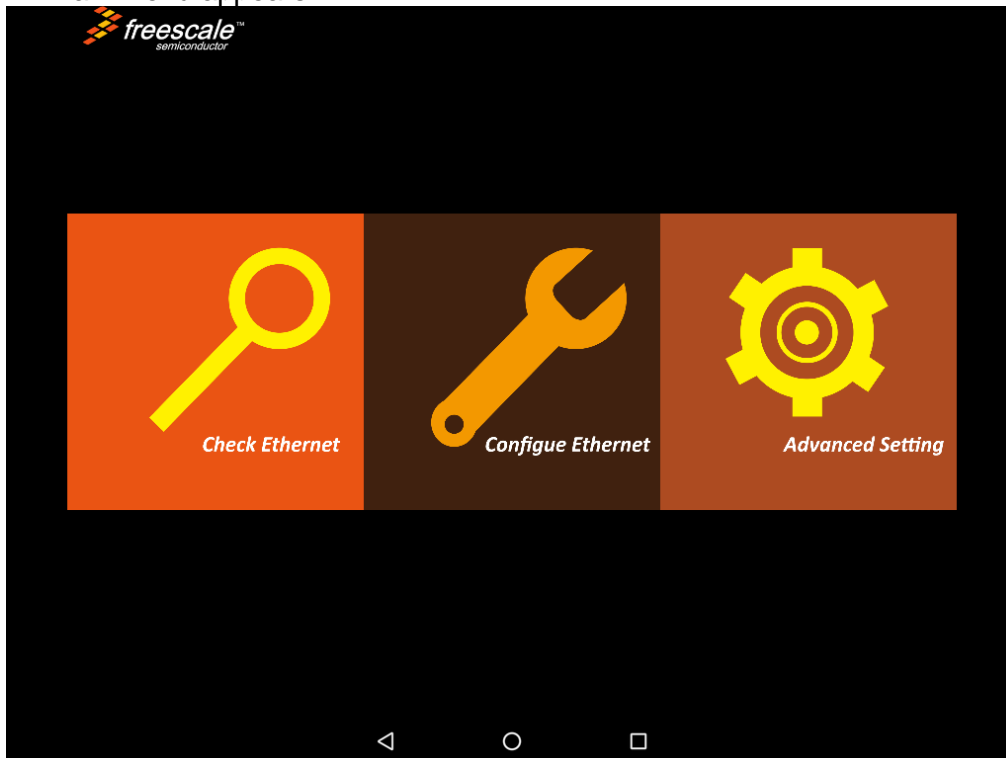

4.4.1 Configuring Ethernet

Go to **All Apps** > **Ethernet** > **Configure Ethernet**

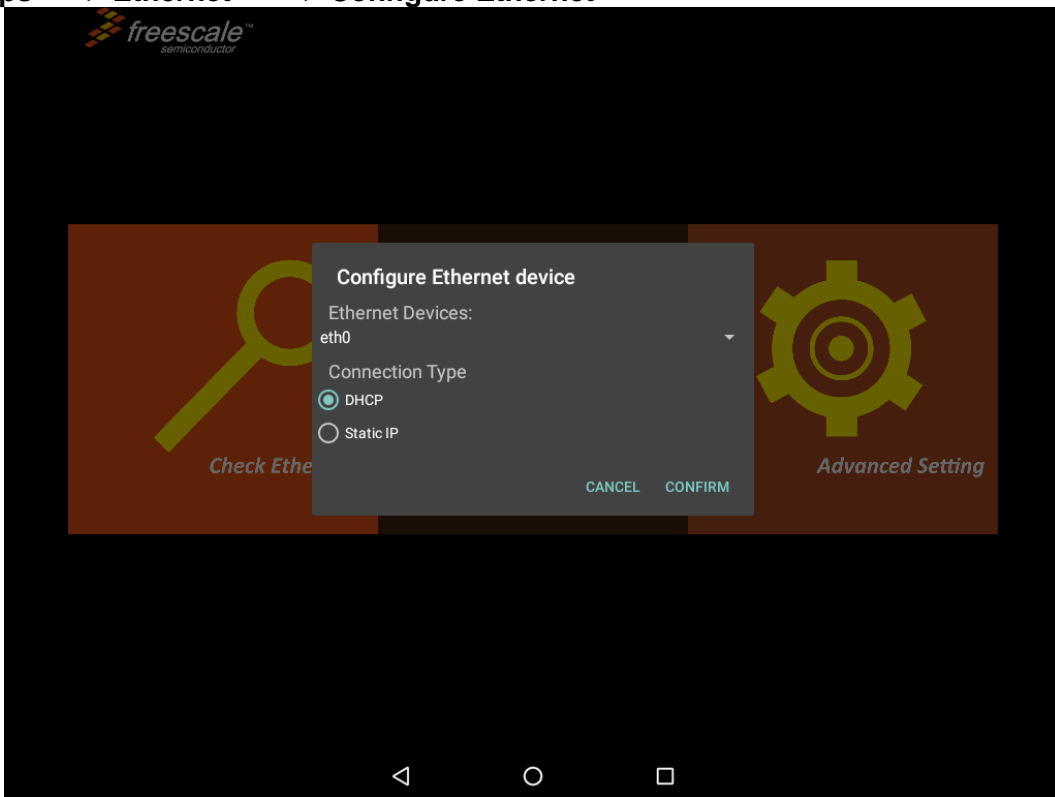

*Ethernet OFF is set by default. Swipe **Ethernet ON** to activate Ethernet connection.

Connection Type

Setting	Description
DHCP	The device automatically capture IP-address from the router
Static IP	Allows to manually set up IP-address, DNS, Network and Gateway

4.4.2 Checking Ethernet Settings

To check Ethernet settings:

Go to **All Apps** > **Ethernet** > **Check Ethernet**

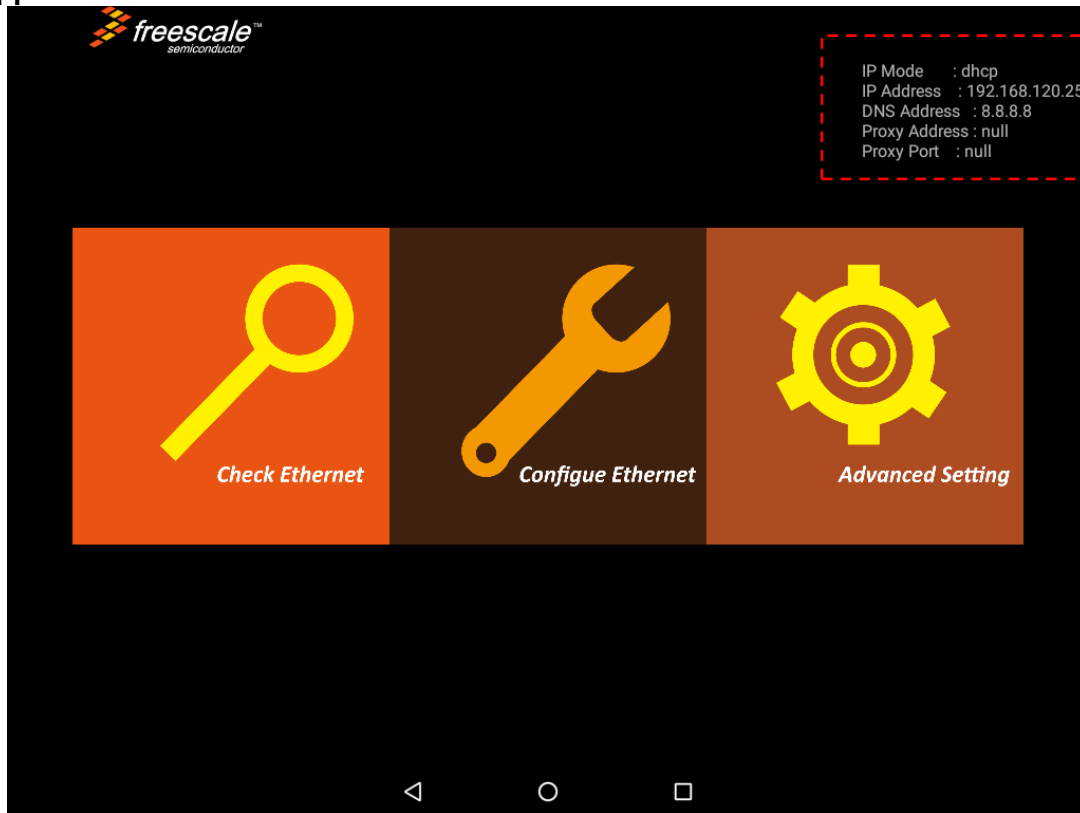

Ethernet settings menu appears on the top right side of the desktop.

4.5 Winmate® Home Manager (WHM)

Winmate® EL-Series HMI comes with preinstalled APP called Winmate® Home Manager (WHM) which let the device manager to lock the launcher then the user can only use one application assigned by the device manager.

4.5.1 How to Lock Applications

To lock applications:

1. In the main APPS window, select the **Home Manager APP**  and tap it to open.

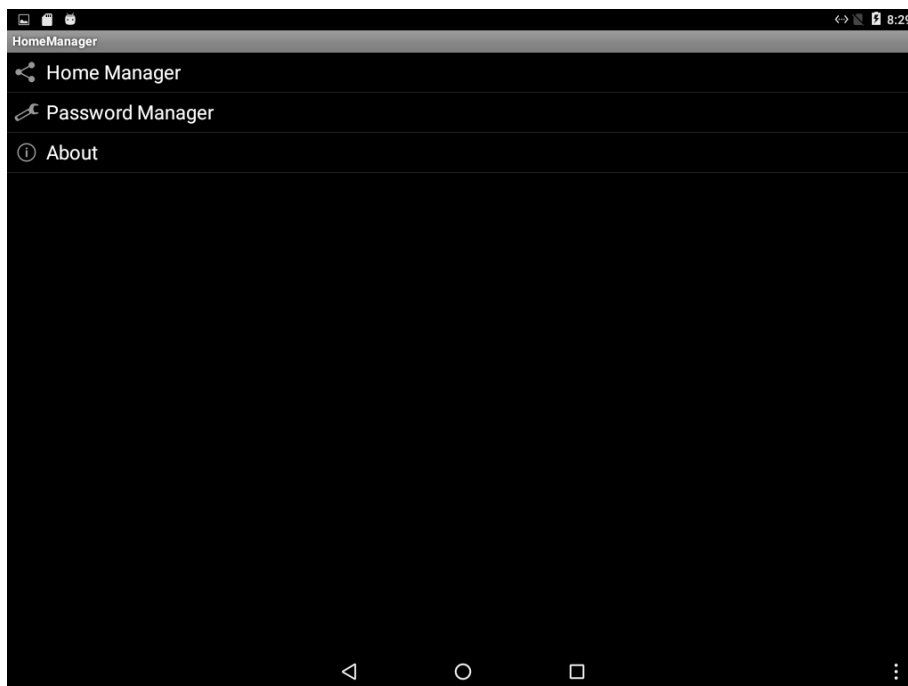
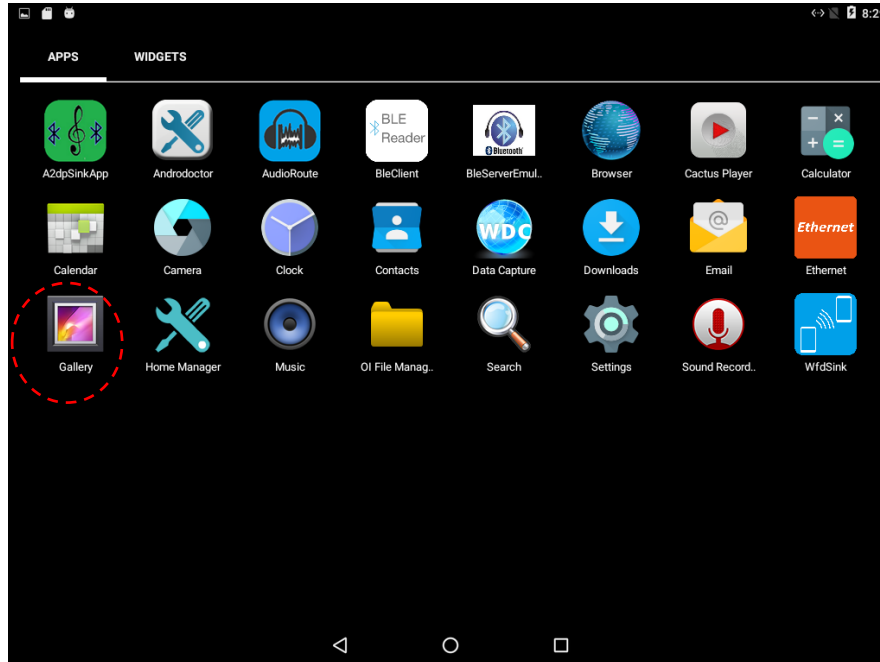

Menu	Description
Home Manager	Set which app you want to run up automatically after booting
Password Manager	Set the WHM password (Default password is “0000”).
About	Displays information about Home Manager

2. Go to **“Application Selector”**, and choose the app which you want to run up automatically after booting.

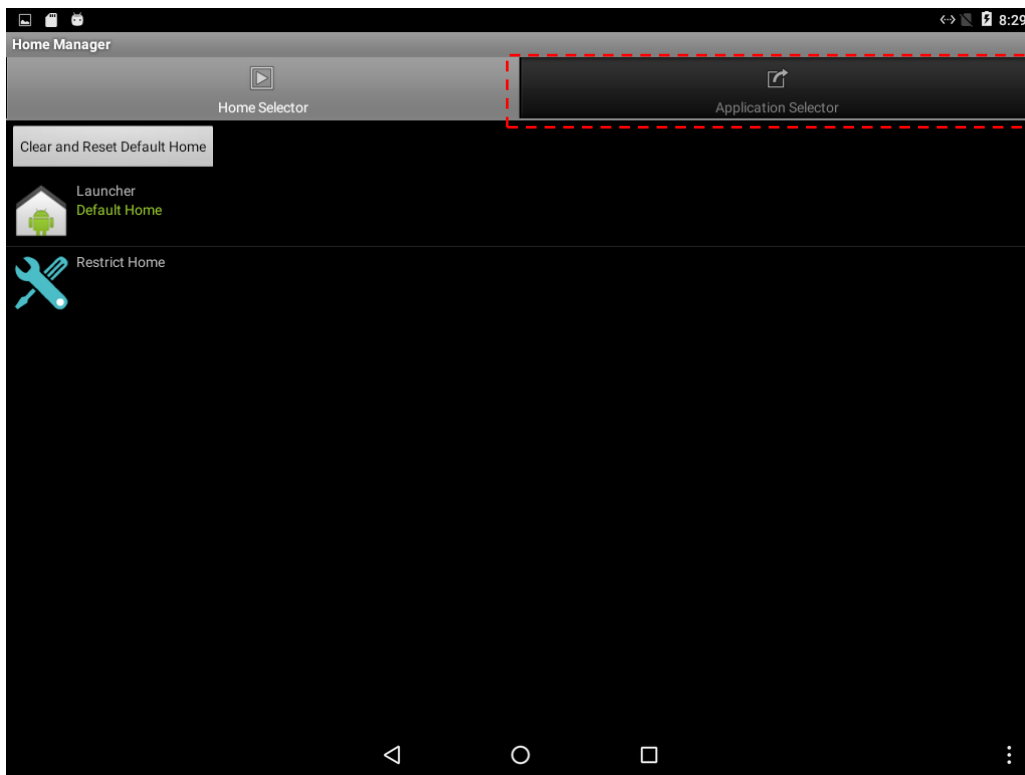

3. Go back to “**Home Selector**” and press “**Clear and Reset Default Home**”.

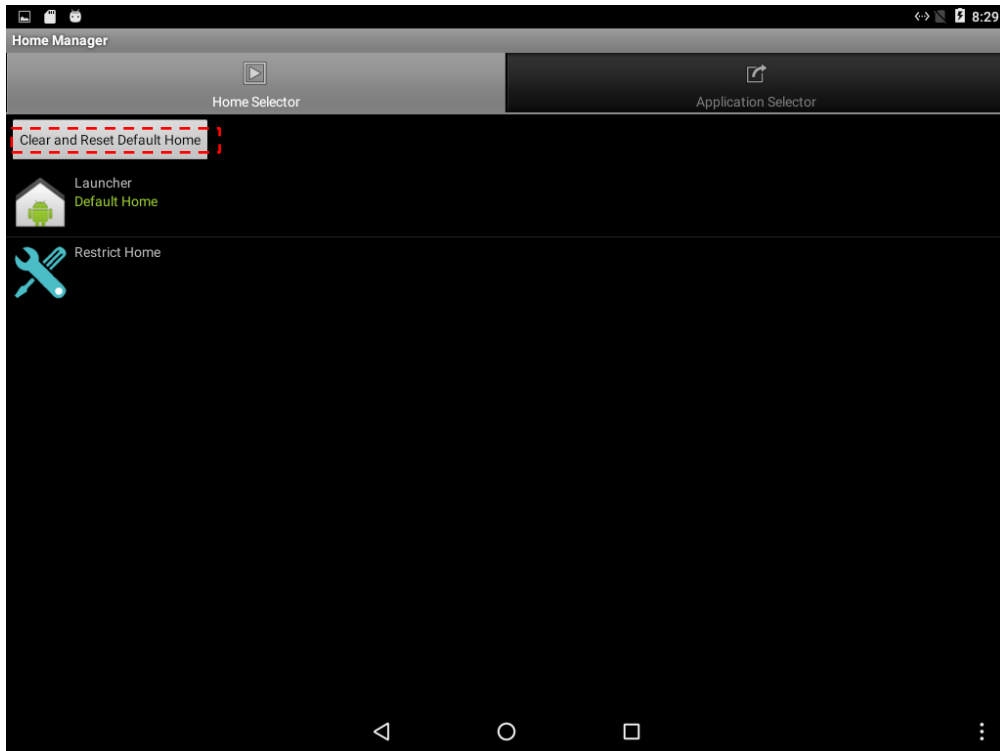

4. Select “**Restrict Home**” and “**Always**”, and then restart the computer to enable these settings.

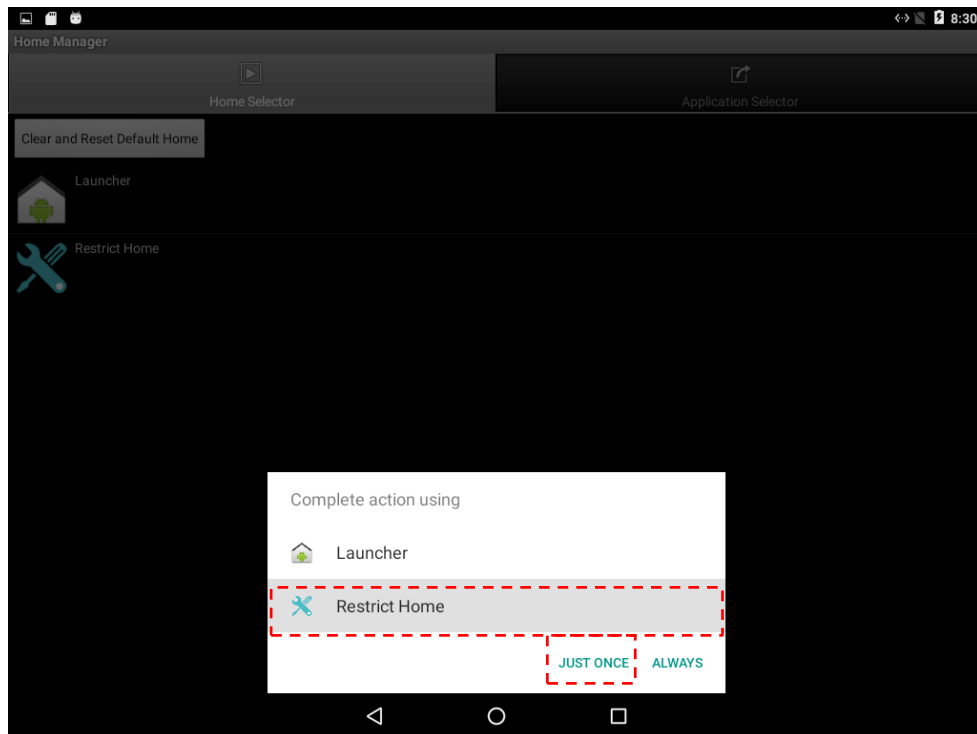

The system will automatically start the application which you selected and lock it. Any time user presses home key or back key; the system will go back to the same application which you have selected.

4.5.2 How to Unlock Applications

Follow the instruction below to reset Home Manager.

1. If you want to reset the home manager, pull down the left side to open the status bar and open **HomeManager**.

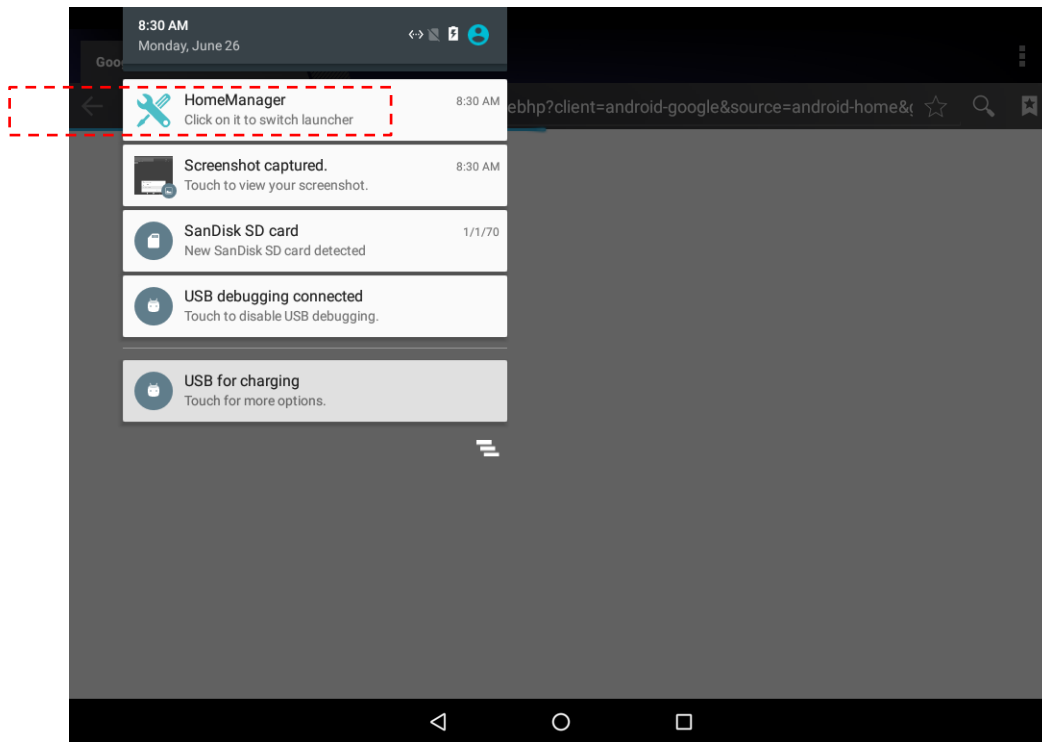

2. System will request the password to login. Touch **OK**.

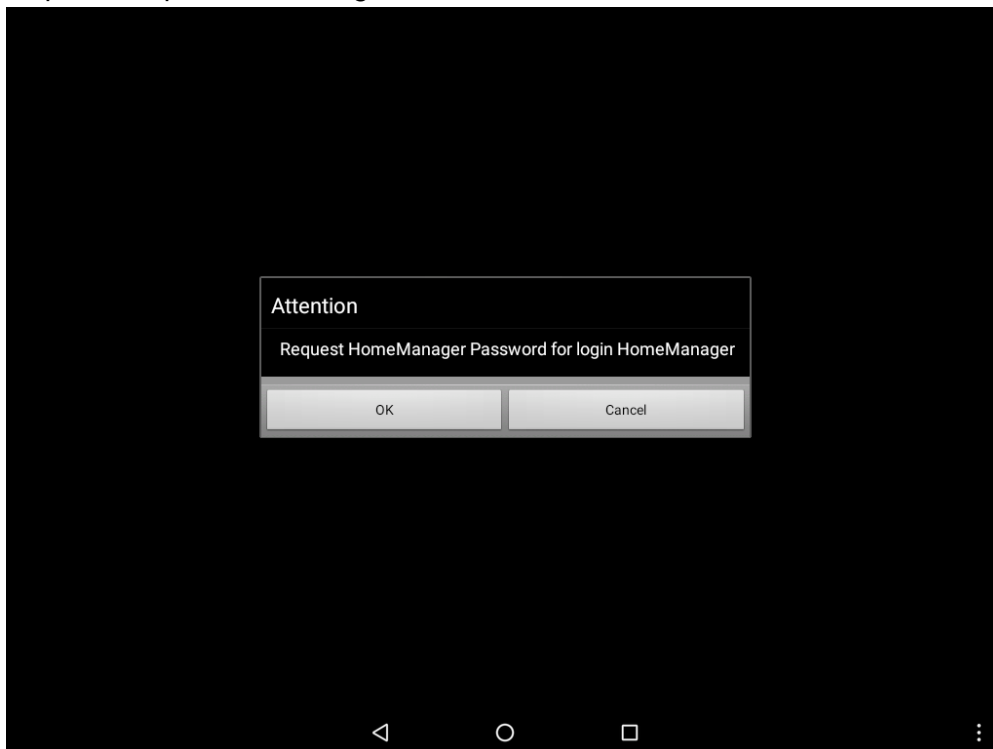

Default password is “0000”.

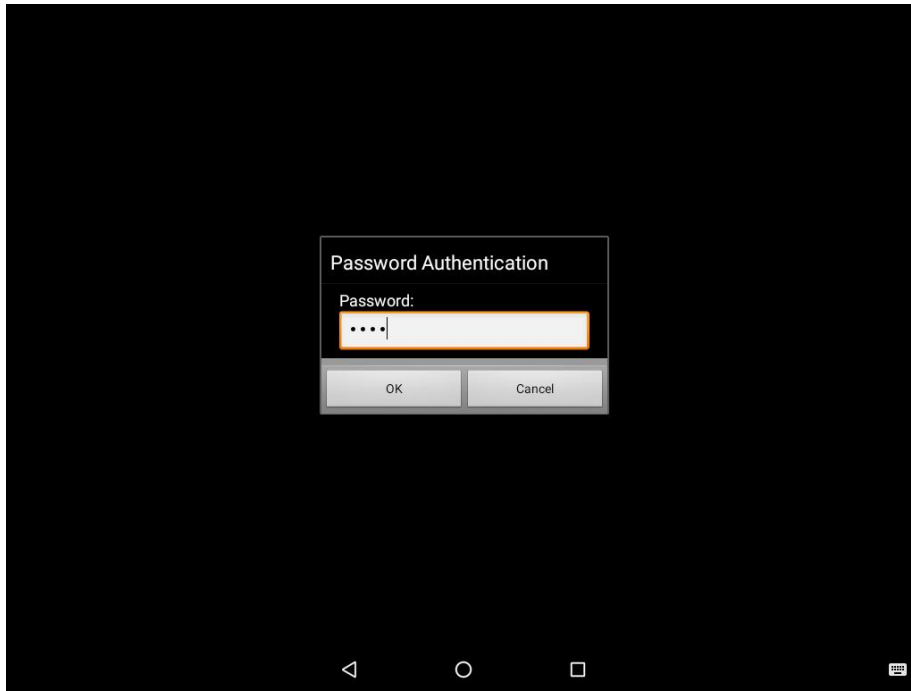

3. Restart the system and you will go back to the normal Launcher.

4.5.3 How to Change Password

To change the password:

1. Go to **Password Manager** and set your own password for this APP.
2. The **default password is "0000"**. Enter a new password in **New Password** field, and then tap **Change Password**.

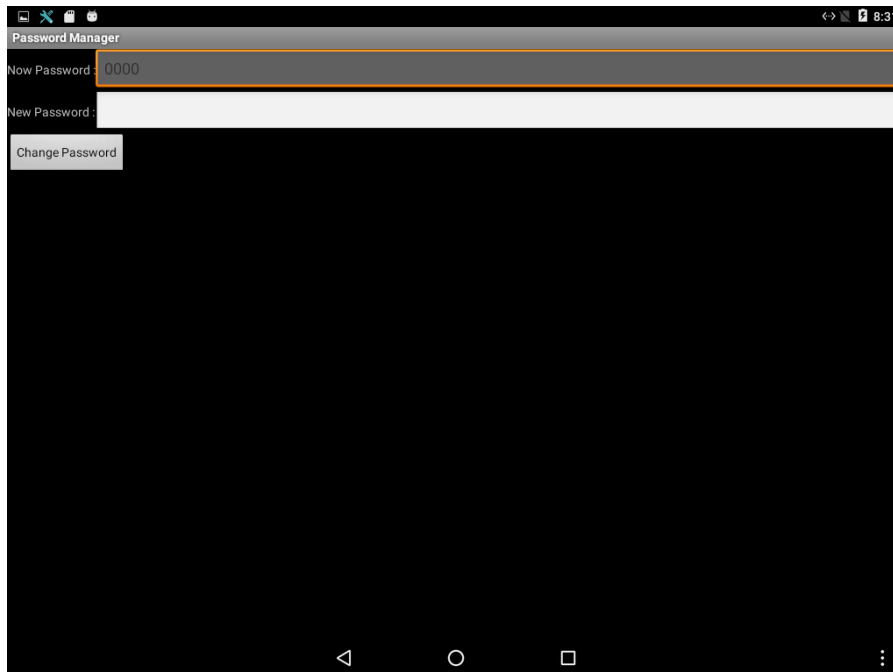

Chapter 5: Software Installation

This chapter contains software installation and updates guide. All the programming guides can be found in the driver CD included in the package.

5.1 Android Debug Bridge (ADB) Driver Installation



Important:

- If your computer is running on Windows Embedded 8 Standard or Windows 8.1 Industry Pro OS system, you need to disable driver signature.
- For Win XP / Win 7 skip disabling driver signature section, and directly proceed to ADB driver installation.

You can find USB OTG driver in the Driver CD that comes in your package. You need to connect HMI device to the computer with the USB OTG cable. When using a USB cable (not supplied with your HMI device), verify that the cable or cable packaging bears the “Certified USB™” mark (see below) to guarantee USB OTG compliance.

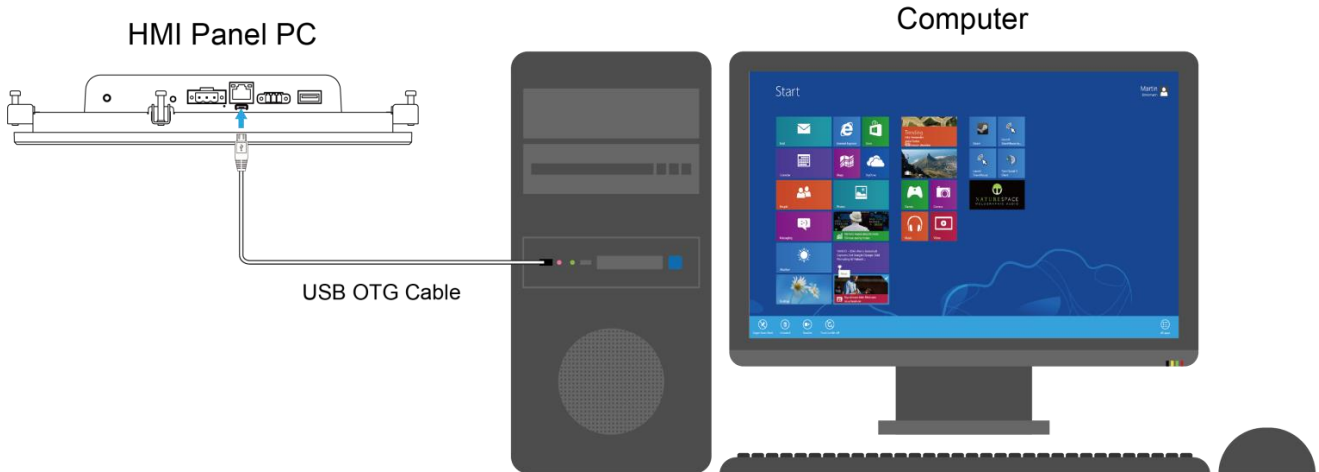

**I/O layout of the HMI device on the picture is for demonstration purposes only. Your I/O layout may vary from the picture above.*

5.1.1 Disabling Driver Signature on Windows 8

1. Hold down the Windows key on your keyboard and press the letter C to open the Charm menu, and then click the gear icon (**Settings**).



2. Click **Change PC Settings**.

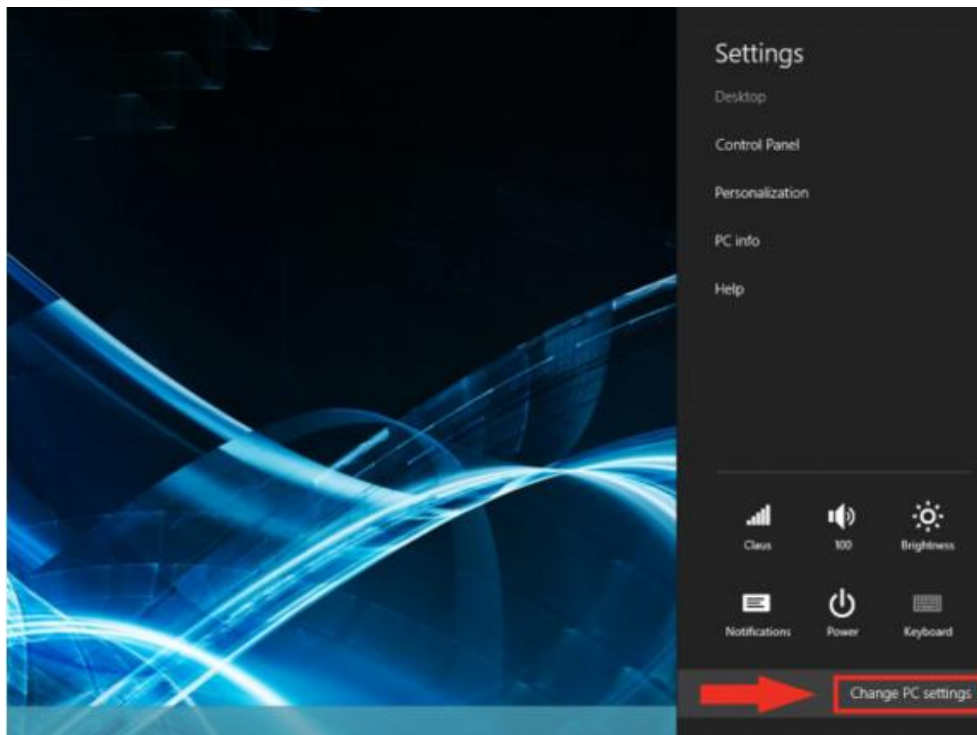

3. Click **General**.
4. Under **Advanced Startup**, click **Restart Now**.

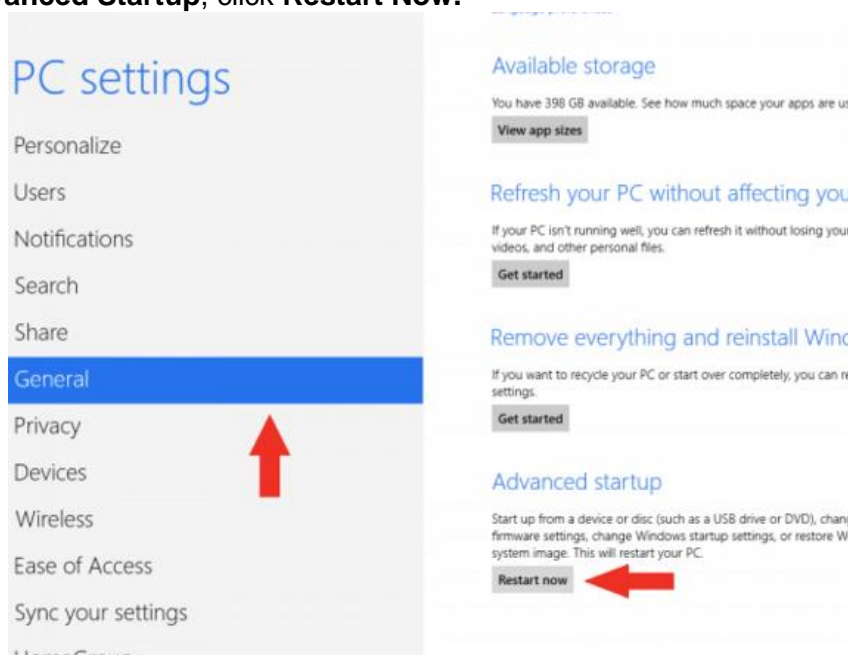

Note: In Windows 8.1, the 'Restart Now' button has moved to 'PC Setting -> Update & Recovery -> Recovery.'

5. After restarting, click **Troubleshoot**.

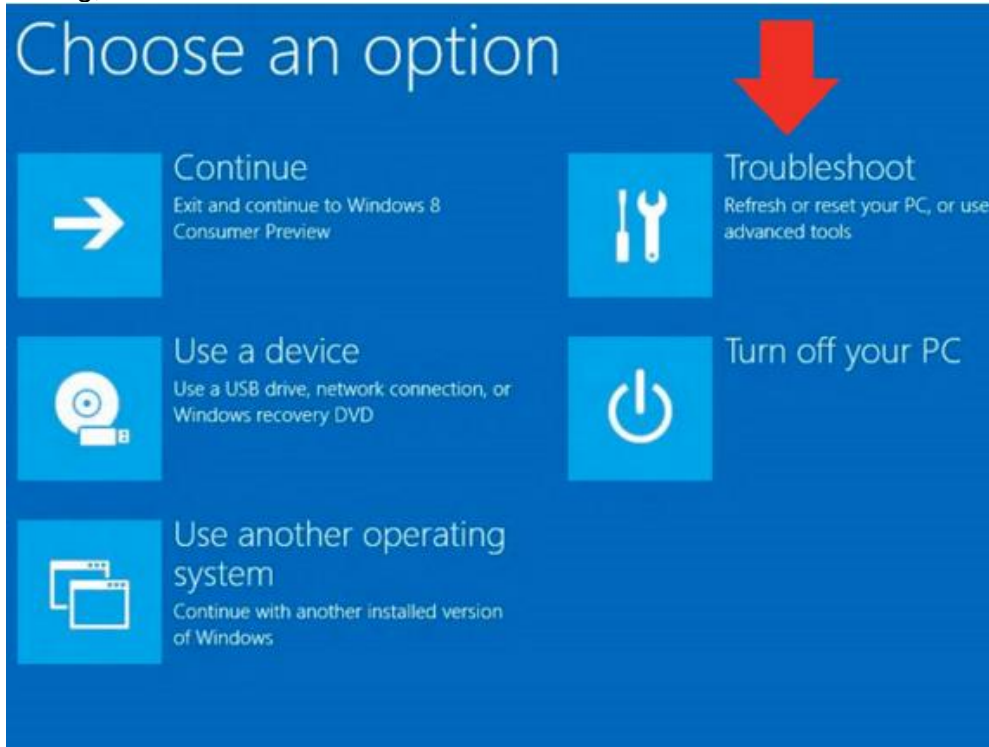

6. Click **Advanced Options**.

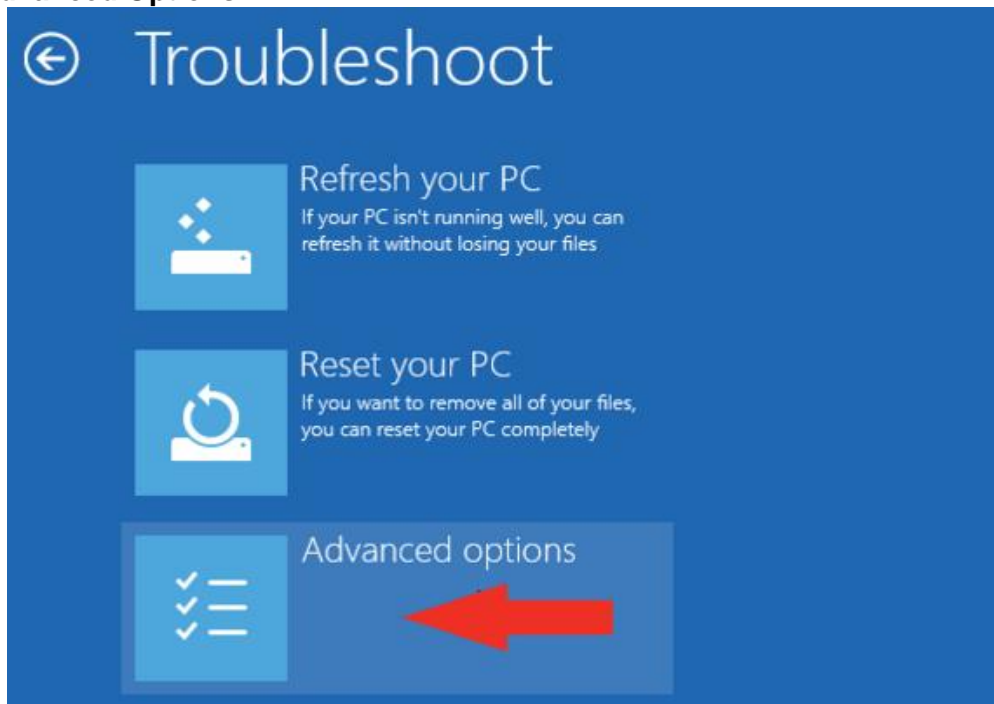

7. Click **Windows Startup Settings**.

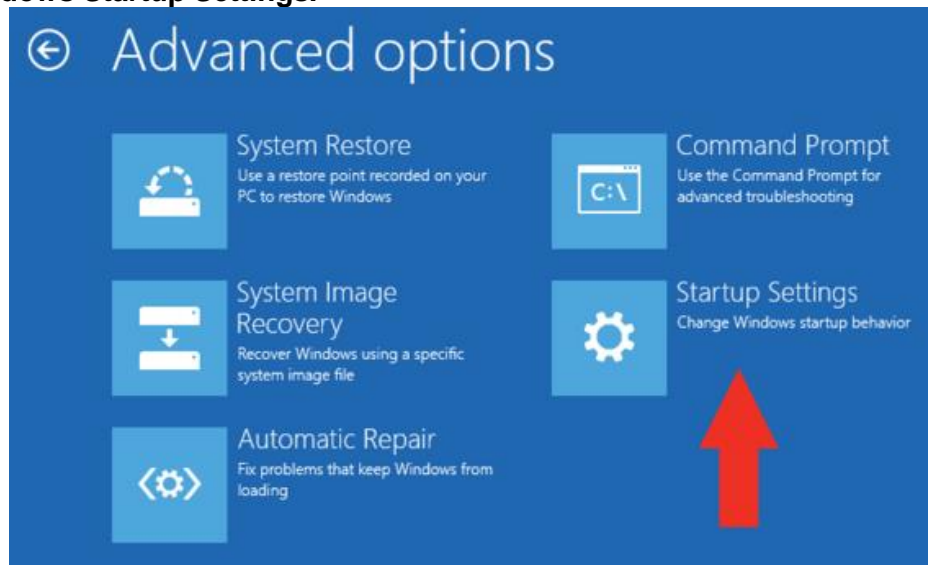

8. Click **Restart**.

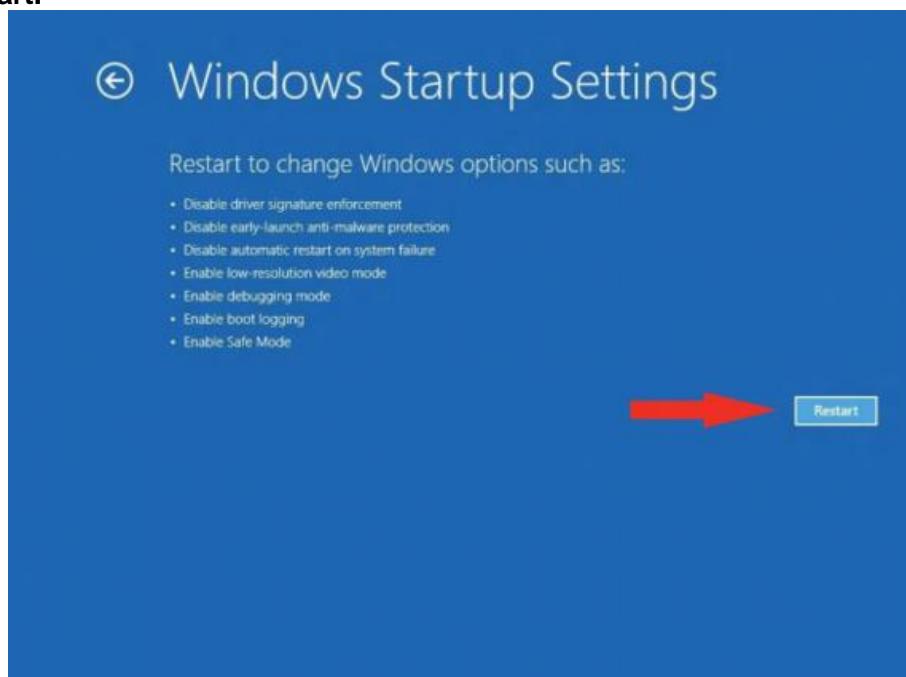

9. After restarting your computer a second time, choose **Disable driver signature enforcement** from the list by typing the number 7 on your keyboard.

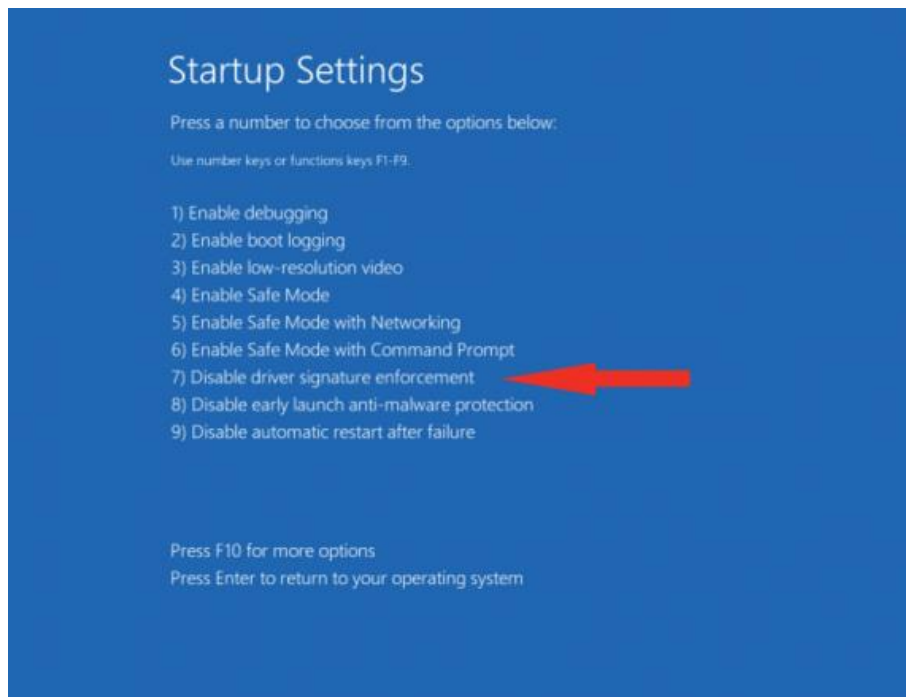

Your computer will restart automatically.

10. After restarting, you will be able to install the ADB drivers normally; however, Windows will display a warning message. When the warning appears, click Install this driver software anyway. If you are unfamiliar with installing drivers, check out our Installing ADB driver tutorial for a step by step guide.

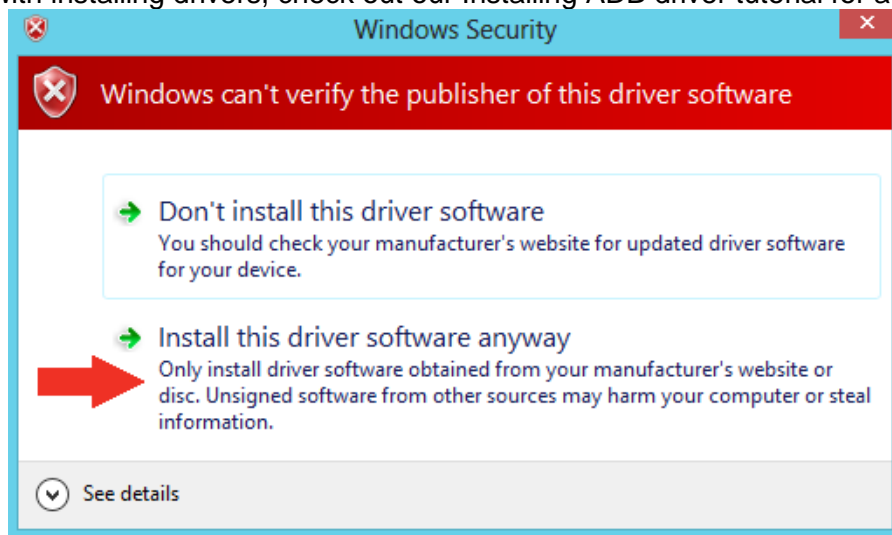

Note:

The next time you restart your computer, driver signature enforcement will be in effect again. You will have to repeat this process for any new boards. If you have multiple boards to use with the same computer, we recommend installing the drivers for each one before you shut down or restart your computer.

5.1.2 ADB Driver Installation

1. Confirm whether the USB device was found by the system.

Device Manager > 120A > Other devices > FA34 > Update Driver Software

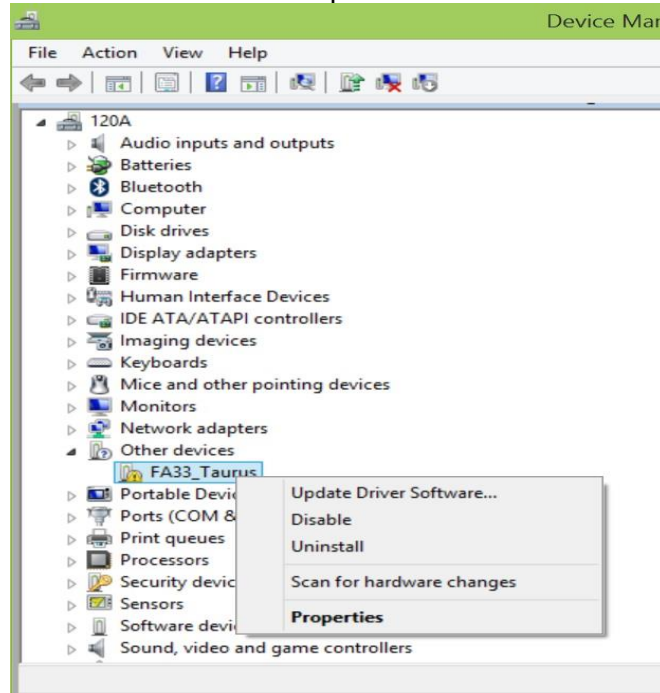

2. In the Update Driver Software window choose **Browse my computer for driver software**.

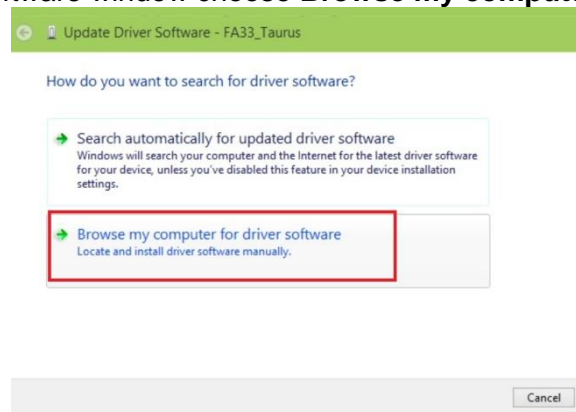

3. Select **Let me pick from a list of device drivers on my computer**. Click **Next**.

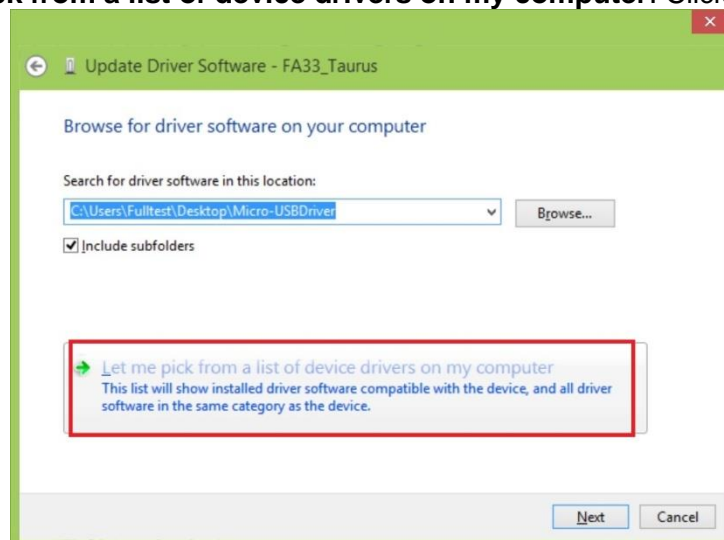

4. Select from your computer
5. In the Update driver software window, click show All Devices and then click **Next**.

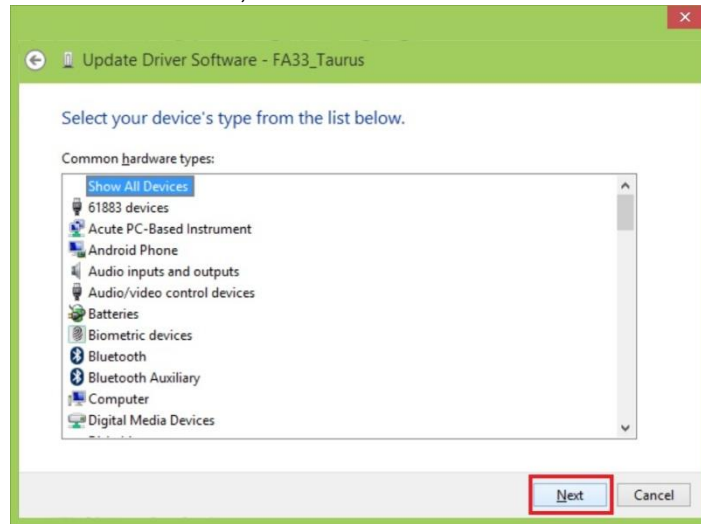

6. The system is looking for the driver folder. Click **Browse**.

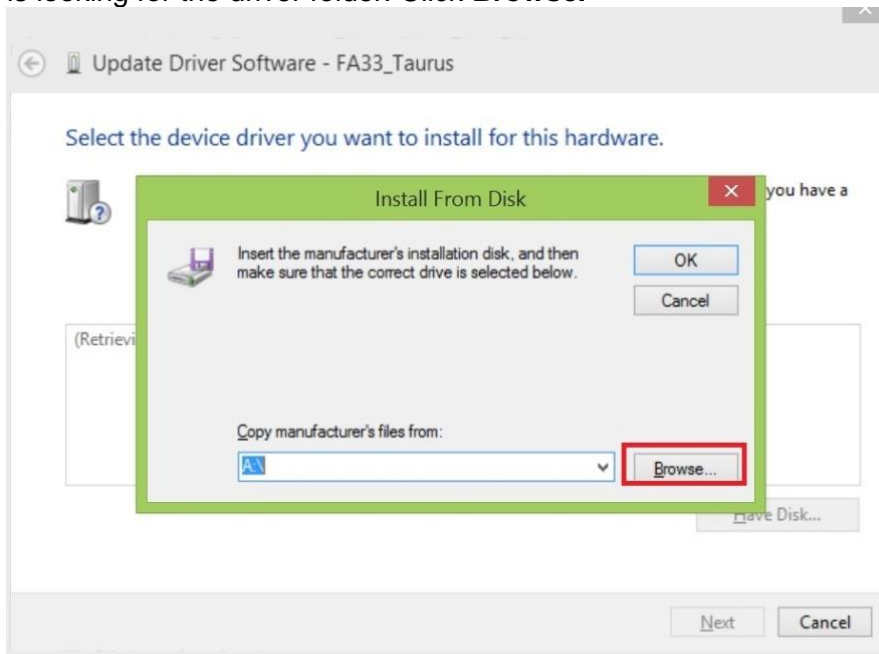

7. Select the driver for your OS system. Click **Open**.

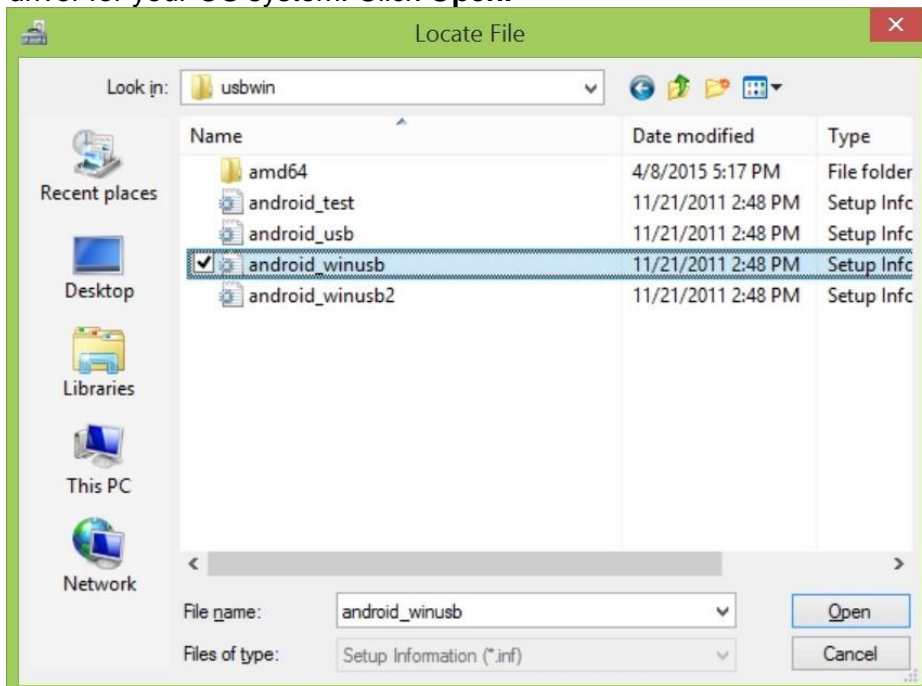

8. Windows Security window will pop up. This message is used to confirm whether the user wants to install the driver. Select **Install this driver software anyway** to continue.



9. When the installation is successfully completed you will see **Android ADB Interface** driver in the Update Driver Software window. Now **adb debug** can be carried out.

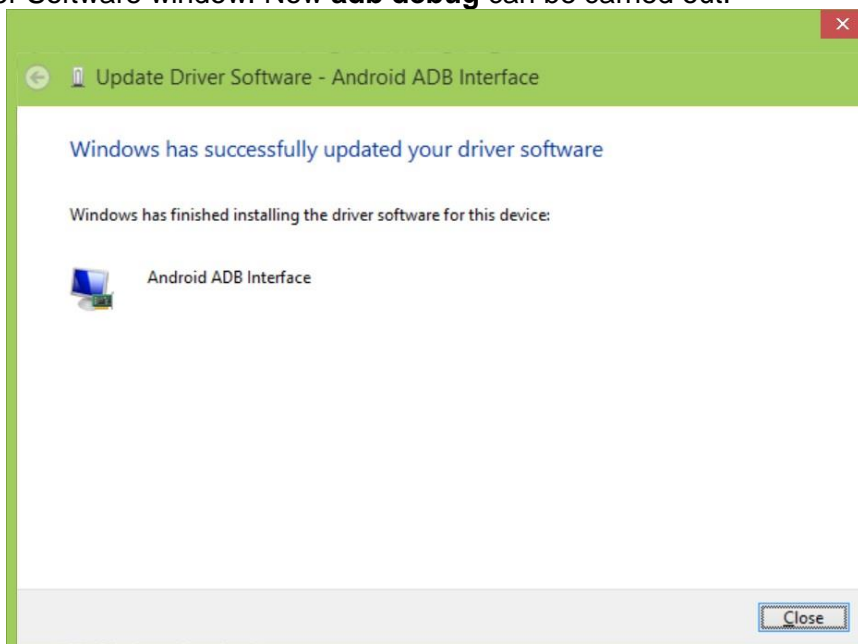

5.2 Installing Android Debug Bridge (ADB)

For detailed Android Debug Bridge (ADB) information refer to Android Developers Platform: <http://developer.android.com/tools/help/adb.html> .

5.2.1 Installing Android Debug Bridge (ADB)

1. Decompress adb.zip. Open ADB terminal and move into the adb archive.

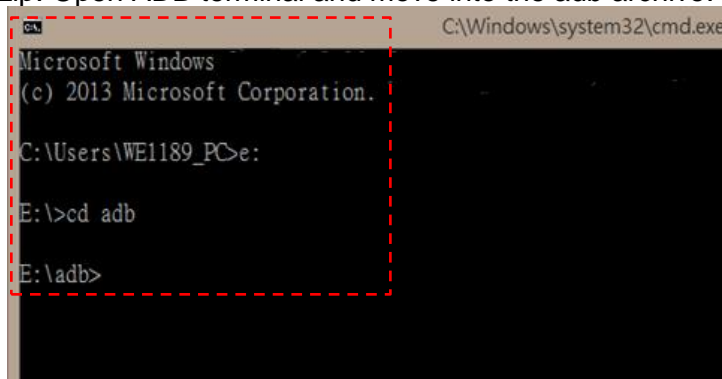

```

C:\Windows\system32\cmd.exe
Microsoft Windows
(c) 2013 Microsoft Corporation.

C:\Users\WE1189_PC>e:
E:\>cd adb
E:\adb>
  
```

ADB Terminal window

2. Connect FA34 motherboard to the computer via USB. FA34 will ask you to confirm USB debugging. Tap **OK**.

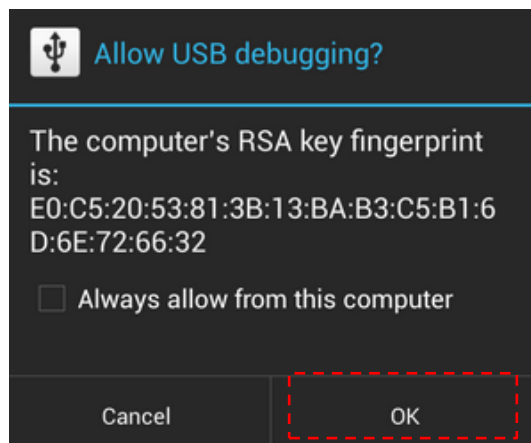

After ADB connection established, install APP or check system log via adb.

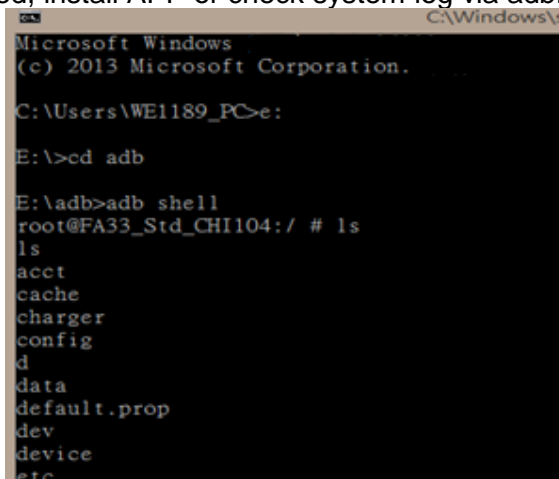

```

C:\Windows\system32\cmd.exe
Microsoft Windows
(c) 2013 Microsoft Corporation.

C:\Users\WE1189_PC>e:
E:\>cd adb
E:\adb>adb shell
root@FA33_Std_CHI104:/ # ls
ls
acct
cache
charger
config
d
data
default.prop
dev
device
etc
  
```

5.2.2 Using Android Debug Bridge (ADB)

1. Open the Command Prompt.
2. Connect SD cord to the HMI device.
3. Go to the Adb directory located in **E:\adb> adb shell**, and connect to the FSL machine.

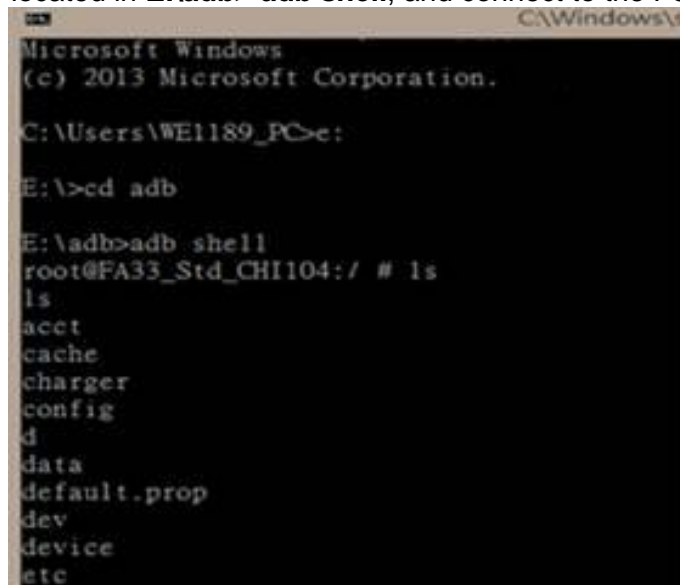

```

Microsoft Windows
(c) 2013 Microsoft Corporation.

C:\Users\WE1189_PC>e:
E:\>cd adb

E:\adb>adb shell
root@FA33_Std_CHI104:/ # ls
ls
acct
cache
charger
config
d
data
default.prop
dev
device
etc
  
```

4. Get dmesg
dmesg 2>&1 | tee /storage/sdcard1/dmesg .log
5. Get logcat command
 - a. **logcat 2>&1 | tee storage/sdcard1/logcat.log**
 - b. When the get action stops, press "Ctrl + C" to leave logcat.

5.3 Downloading Image Tool

Download OS Image Tool update guide:

Winmate Download Center

<http://www.winmate.com/> > Support > Download Center > Multi-touch PPC > EL-Series HMI > OS Image

5.4 OTA Update Guide

OTA is a tool which can help you to update OS image. To receive Android OS image file contact our sales representatives. Once you get the image file follow the guideline below.

1. Copy image files **ota_FA3X_X_X_X_X.zip** and **FA3X_X_X_X_X.md5** and to micro SD card.
 2. Insert micro SD card to the slot in the computer.
- In the **APPS** menu tap **OTA Image Upd**.

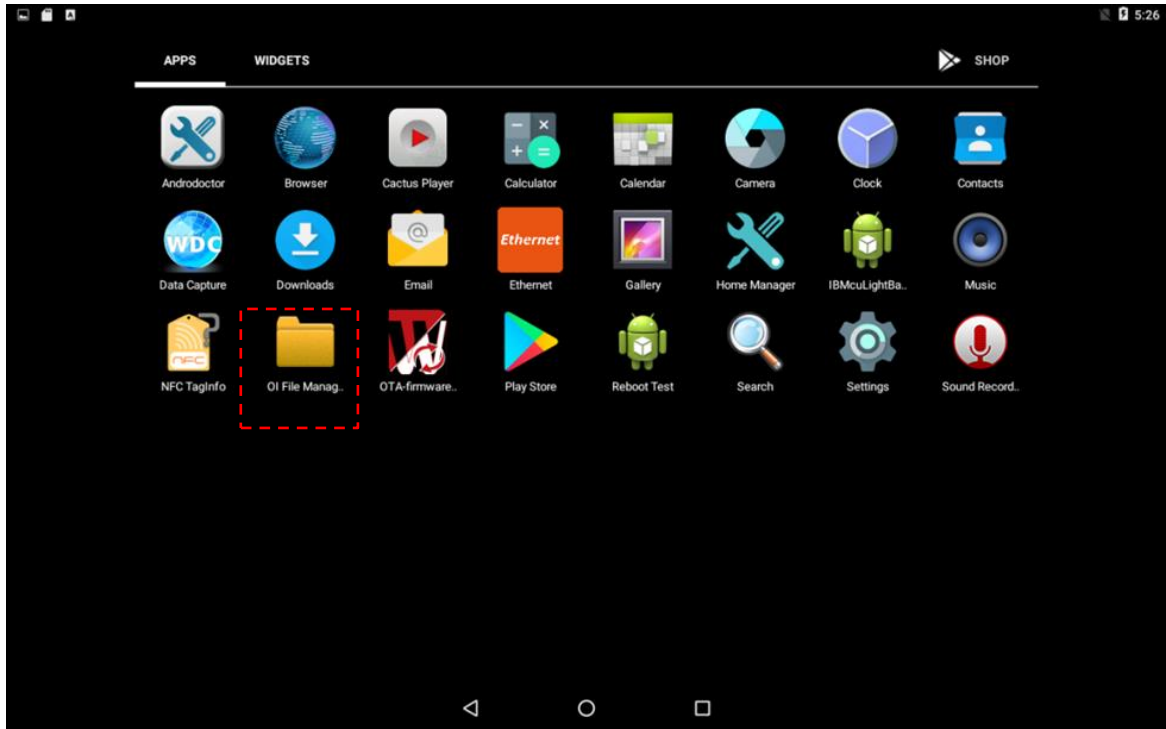

System shows OTA firmware related information.

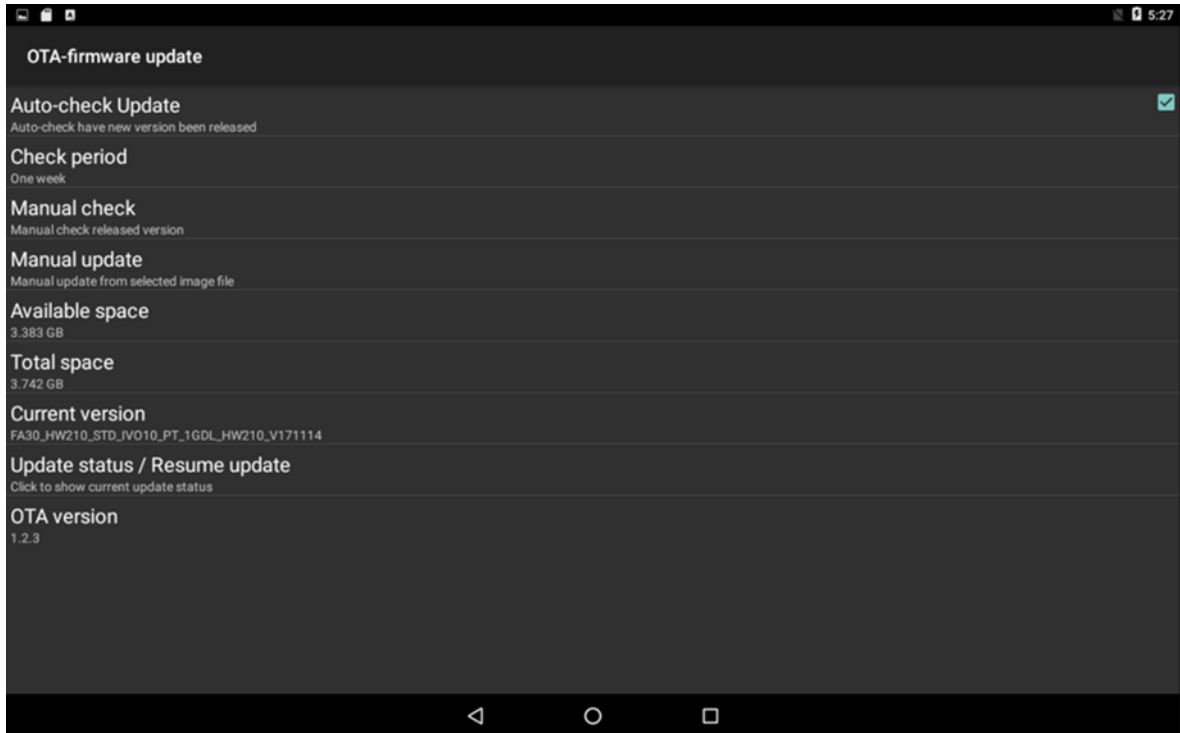

3. Click Auto-check Update. The system is checking OTA File. It may take some time.

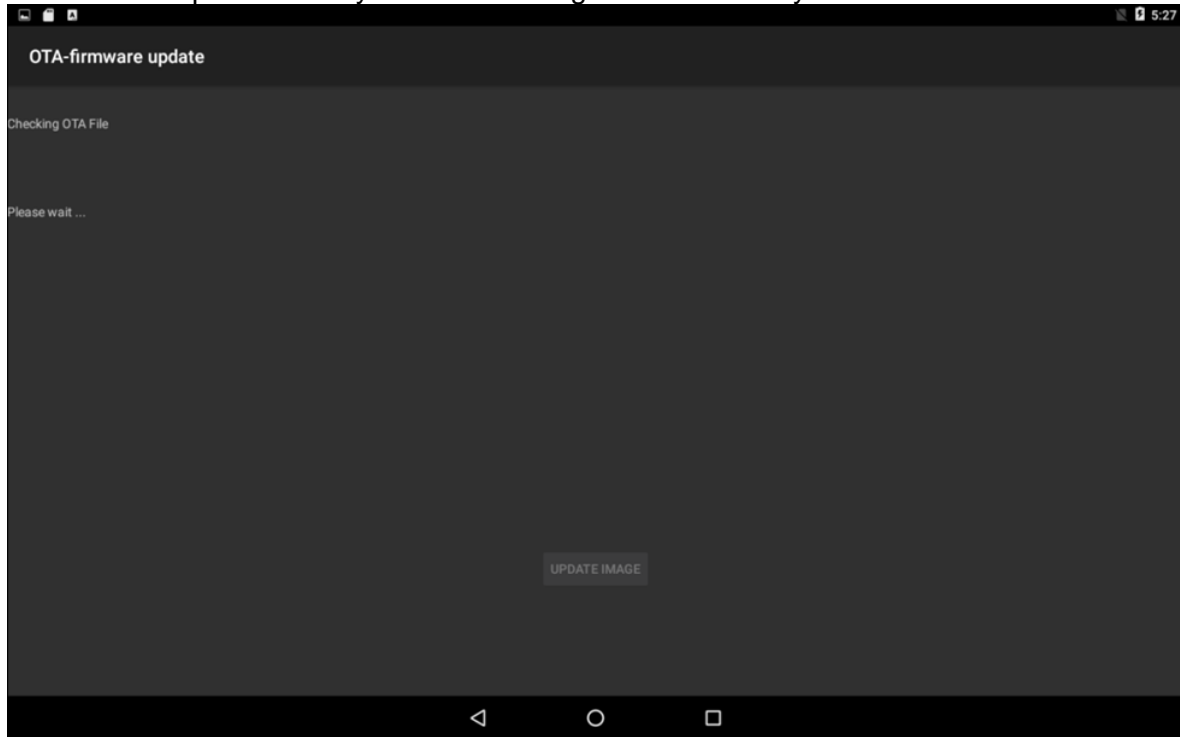

4. Tap **Update Image**

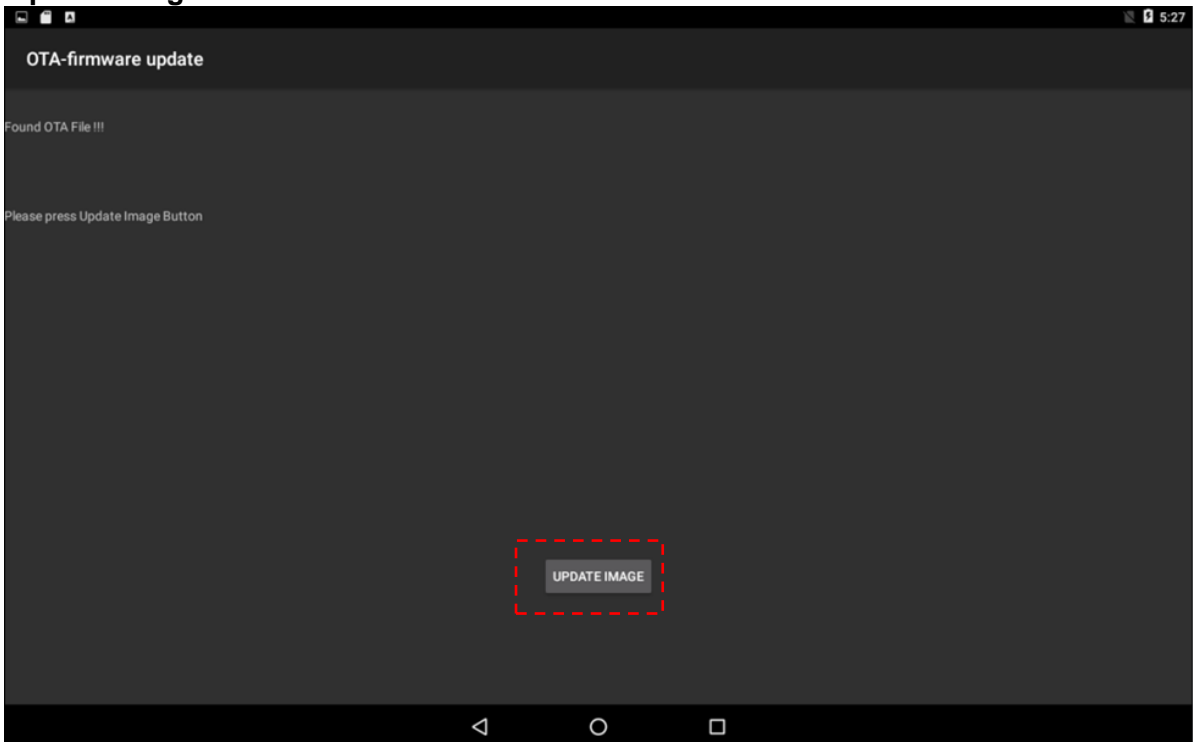

- 5. Make sure the file founded by the system is image update file. Tap **OK**.

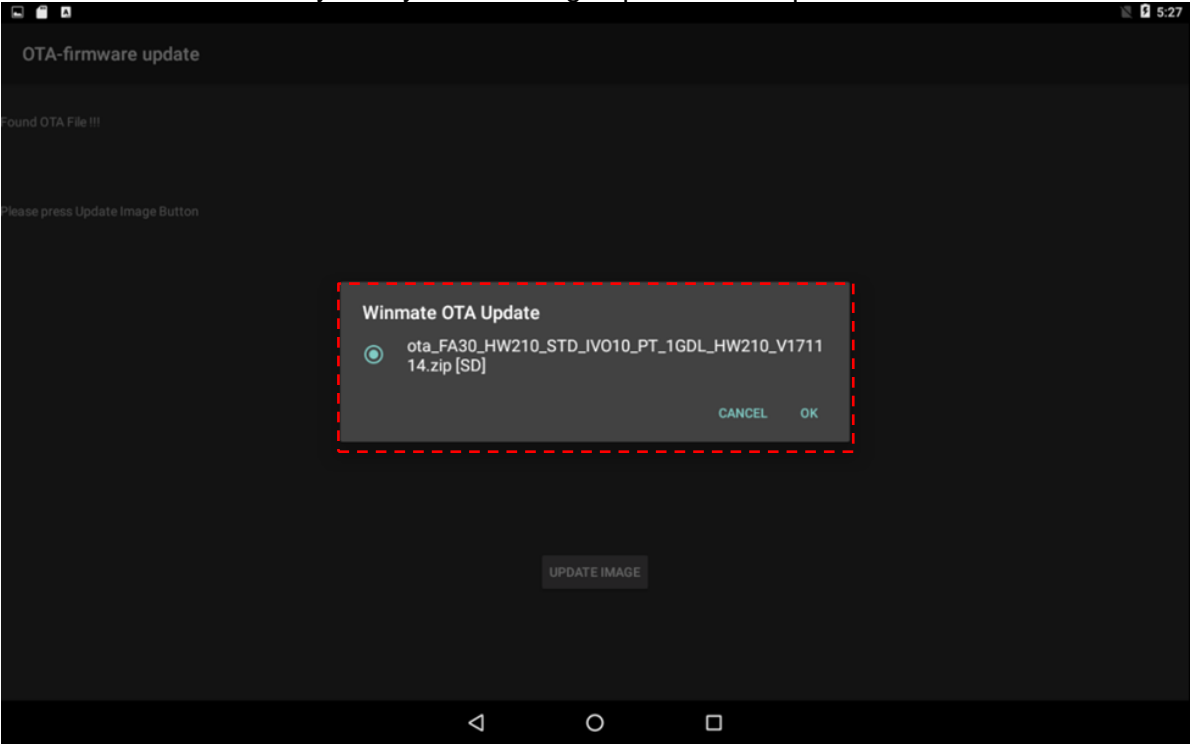

- 6. Make sure the battery level is at least 50%. Tap **OK**.

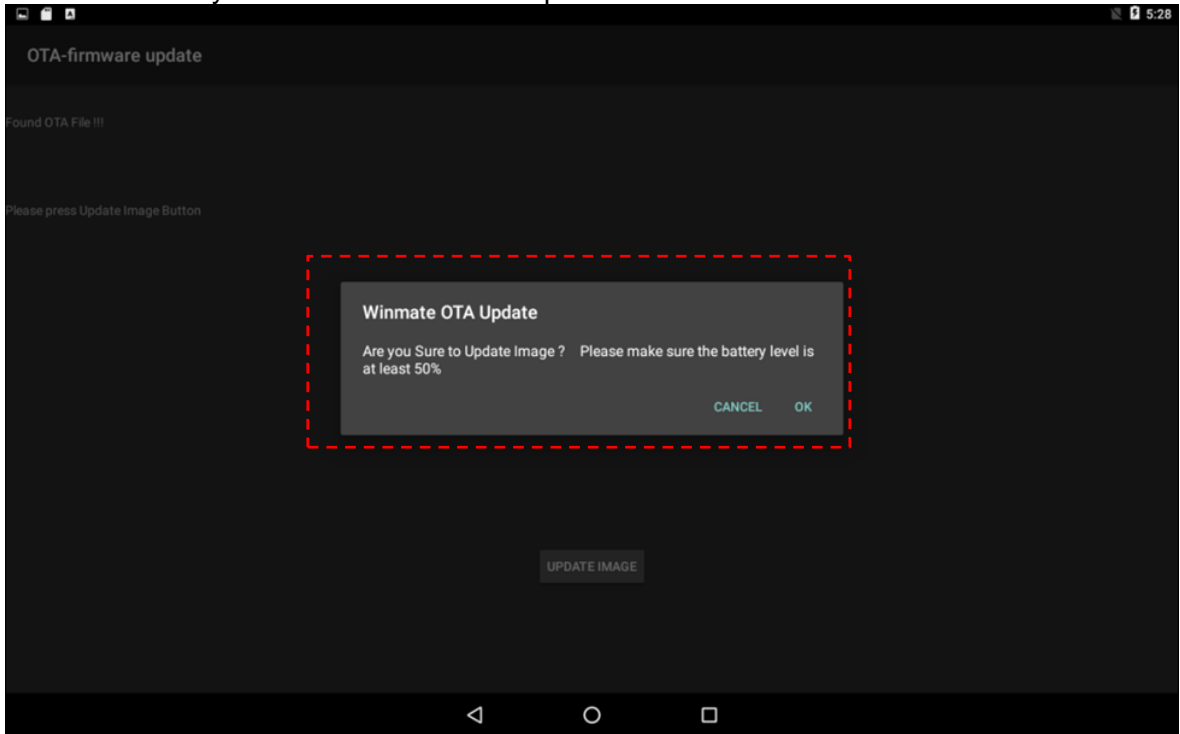

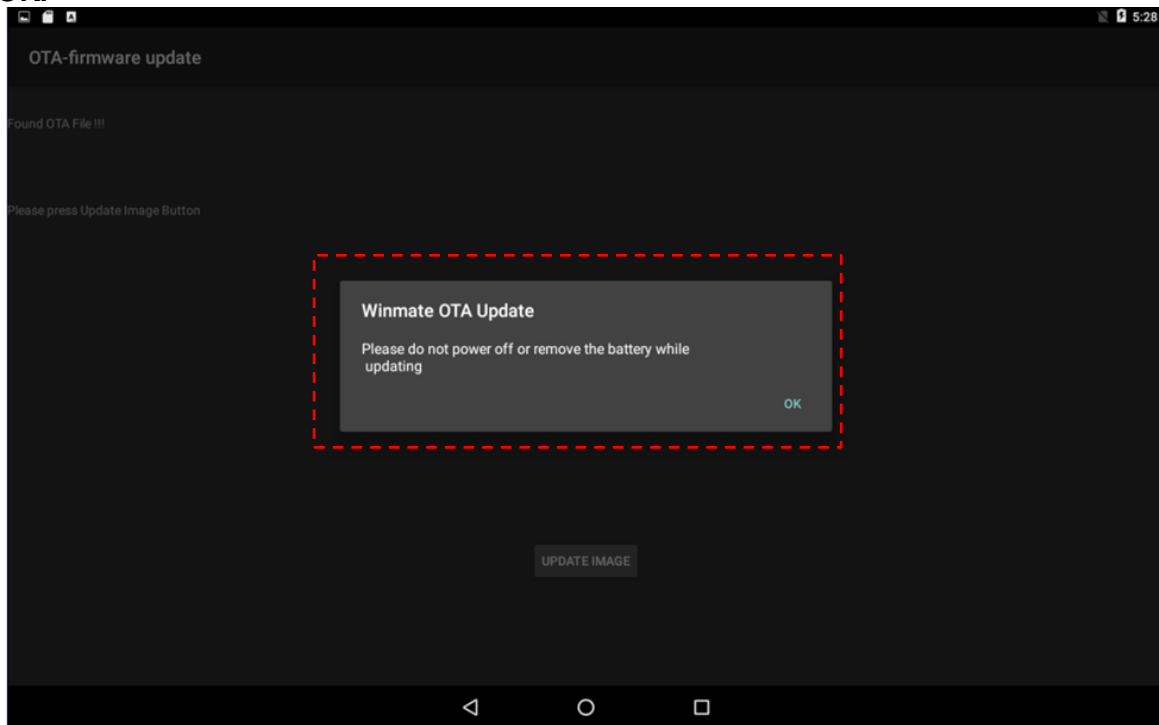
7. Tap **OK**.**Important:**

Do not disconnect the power source!
Do not remove the battery!

8. After update the system will automatically restart.

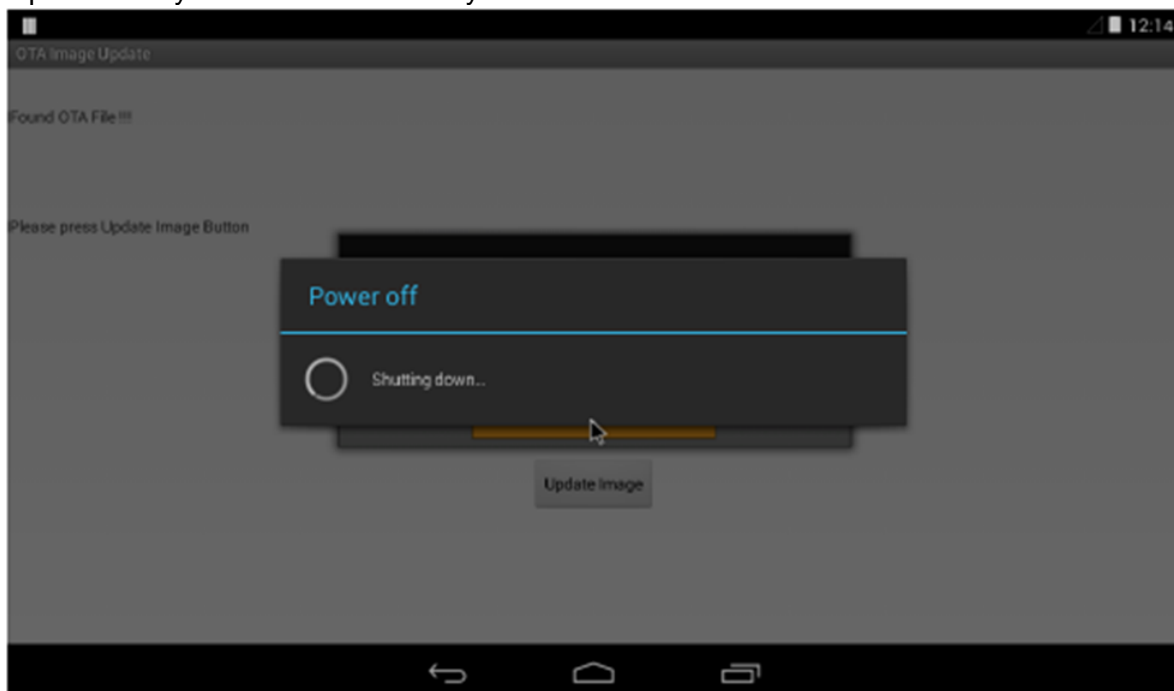

5.5 OS Image Update Guide

Download OS Image update guide from Winmate Download Center or Winmate File Share.

Winmate Download Center:

<http://www.winmate.com/DownCenter/DownLoadCenter.asp?DownType=3018>

Chapter 6: Technical Support

This chapter includes the directory for technical support. Free technical support is available from our engineers every business day. We are always ready to give advice on application requirements or specific information on the installation and operation of any of our products.

Appendix A: Product Specifications

Hardware Specifications

	Model Name				
	W04FA3S-ELT1	W05FA3S-ELT1	W07FA3S-ELT1	W10FA3S-ELH2	W15FA3S-ELA4
Display					
Size/ Type	4.3" TFT	5.6" TFT	7" TFT	10.1" TFT	15.6" TFT
Resolution	480 x 272	1024 x 600	1024 x 600	1280 x 800	1920 x 1080
Brightness	400 nits	300 nits	320 nits	350 nits	300 nits
Contrast Ratio	1000:1 (typ.)	400 : 1 (typ.)	500 : 1 (typ.)	800:1 (typ.)	800:1 (typ.)
Viewing Angle	-75~50 (H); -75~75 (V)	-40~40 (H); -20~30 (V)	-70~70 (H); -50~60 (V)	-85~85 (H); 85~85 (V)	-85~85 (H); 85~85 (V)
Max Colors	16.7M (8 bit)	256k (6bit)	16.7M (8 bit)	16.7M (8 bit)	262K (8 bit)
Touch	Projected capacitive	Projected capacitive	Projected capacitive	Projected capacitive	Projected capacitive
Mechanical Specifications					
Dimensions, mm	121.05 x 82.05 x 49	158.7 x 116.3 x 51	184.94 x 127.7 x 44.9	267.42 x 182.14 x 57.6	387.6 x 257.7 x 52.5
Cutout, mm	109.6 x 71.2	145.7 x 103.3	174.08 x 116.9	244 x 159	371.6 x 223.5
Mounting	Panel Mount, RAM Mount	Panel Mount, RAM Mount	Panel Mount, VESA 75x75	Panel Mount, VESA 75x75	Panel Mount, VESA 75x75
Cooling	Fanless	Fanless	Fanless	Fanless	Fanless
Input / Output Connectors					
Power	Terminal block 3-pin	Terminal block 3-pin	Terminal block 3-pin	Terminal block 3-pin	Terminal block 3-pin
Ethernet	1 x RJ45, 10/100/1000 LAN	1 x RJ45, 10/100/1000 LAN	1 x RJ45, 10/100/1000 LAN	1 x RJ45, 10/100/1000 LAN	1 x RJ45, 10/100/1000 LAN
USB Ports	1 x USB 2.0	1 x USB 2.0	1 x USB 2.0	1 x USB 2.0	1 x USB 2.0
USB OTG	1 x USB OTG	1 x USB OTG	1 x USB OTG	1 x USB OTG	1 x USB OTG
COM Port	1 x RS-485	1 x RS-485	1 x RS-485	1 x RS-485	1 x RS-485
System Specifications					
Processor	Freescall Cortex® A9 i.MX6 Dual Core,1GHz (Optional Quad Core)	Freescall Cortex® A9 i.MX6 Dual Core,1GHz (Optional Quad Core)	Freescall Cortex® A9 i.MX6 Dual Core,1GHz (Optional Quad Core)	Freescall Cortex® A9 i.MX6 Dual Core,1GHz (Optional Quad Core)	Freescall Cortex® A9 i.MX6 Dual Core,1GHz (Optional Quad Core)
Memory	1GB LPDDR3	1GB LPDDR3	1GB LPDDR3	1GB LPDDR3	1GB LPDDR3
Storage	8 GB eMMC	8 GB eMMC	8 GB eMMC	8 GB eMMC	8 GB eMMC
OS	Android 6.0, Ubuntu 16.04	Android 6.0, Ubuntu 16.04	Android 6.0, Ubuntu 16.04	Android 6.0, Ubuntu 16.04	Android 6.0, Ubuntu 16.04
Power Specifications					
Power Input	12-24V DC with isolation	12-24V DC with isolation	12-24V DC with isolation	12-24V DC with isolation	12-24V DC with isolation
Power Consumption	7 W	7W	7.5 W	10 W	12 W
Environment Considerations					
Operating Temp.	-20°C to +50°C	-20°C to +50°C	-20°C to +50°C	-20°C to +50°C	-20°C to +50°C
Operating Humidity	10 ~ 90% (non-condensing)	10 ~ 90% (non-condensing)	10 ~ 90% (non-condensing)	10 ~ 90% (non-condensing)	10 ~ 90% (non-condensing)
Certification					
Safety	CE, FCC	CE, FCC	CE, FCC	CE, FCC	CE, FCC
Vibration	EN60068-2-6	EN60068-2-6	EN60068-2-6	EN60068-2-6	EN60068-2-6

Winmate Inc.
9F, No.111-6, Shing-De Rd., San-Chung District,
New Taipei City 24158, Taiwan, R.O.C
www.winmate.com

