

M116AD

11.6" Windows Rugged Tablet PC with Intel® Core™ i5-1235U



KEY FEATURES

- 11.6" 1920 x 1080, 850 nits IPS LED Panel with direct optical bonding
- Intel® Core™ i5-1235U Alder Lake processor
- IP65 waterproof and dustproof, MIL-STD-810H shock, vibration and drop resistance
- Sunlight readable with antiglare solution
- Hotswappable battery design
- USB TypeC port support power delivery 20V In



SPECIFICATIONS

Display			
Bonding	Optical Bonding for Sunlight Viewability	Resolution	1920x1080
Size	11.6 inches	Contrast Ratio	1000:1
Panel Brightness	850.0 nits	View Angles	85,85,85,85
Type	Projected Capacitive Multi Touch	Viewability	Anti-Glare touch treatment
Touch Mode	Support Hand/Rain, Stylus, Glove Mode		
System Specification			
Processor	Intel Core i5-1235U (up to 4.4GHz)	Memory	8GB DDR5 SDRAM 16GB DDR5 SDRAM (Optional) 32GB DDR5 SDRAM (Optional)
Storage	256GB M.2 NVMe SSD Additional storage available with micro SDXC card slot (Optional) 512GB M.2 NVMe SSD (Optional) 1TB M.2 NVMe SSD (Optional) 2TB M.2 NVMe SSD (Optional)	Security	Trusted Platform Module (TPM) 2.0 Kensington Lock
Operating System	Windows 10 IoT Enterprise LTSC (64 bit) Windows 11 IoT Enterprise SAC (64 bit) (Optional)	WLAN	Support
BT	Support	WWAN	4G LTE (Optional) 5G (Optional)
GNSS	GPS, GLONASS	RFID	HF RFID reader 13.56 MHz (Optional)
Sensors	Light sensor/ G-sensor / Gyro		
Camera			
Front Camera	2MP Front Camera	Rear Camera	8MP Rear Camera with auto-focus and LED light
Mechanical			
Dimension	300.67 x 201.97 x 22.5 mm	Weight	1.4 kg (3.1 lbs) with standard battery
Cooling System	Fan design		
IO Ports			
USB Port	1 x USB 3.0 (Type A), 1 x USB 3.0 (Type-C support Power Delivery 20V In)	SD Card Slot	1 x Micro SDXC slot
SIM Card Slot	1 x Micro SIM card slot	Video	1 x Micro HDMI (Optional)
Audio	1 x Audio combo 3.5mm audio combo jack Dual Digital Mic With Noise Cancellation	LAN	1 x RJ45-10/100/1000 GigaLAN port (Optional)
Indicator	4x LED Indicator for Power, Battery, HDD, RF status	Docking Connector	1 x 19-pin docking connector

Environment			
Operating Humidity	10% to 90% RH, non-condensing	Operating Temperature	-20°C to 60°C
Storage Temperature	-30°C to 70°C (-22°F to 158°F)	Shock	MIL-STD-810H Method 516.8 Procedure I
Vibration	MIL-STD-810H Method 514.8 Procedure I	IP rating	IP65
Drop	MIL-STD-810H Method 516.8, 4 ft	EMC	MIL-STD-461G CE101, CE102, RE101, RE102, CS118 (Default) MIL-STD-461G CS101, CS114, CS115, CS116, RS101, RS103 (Optional)

Certification	
Certification	CE, FCC

Security Function			
SOTI MobiControl	SOTI MobiControl Compliance	Kensington Lock	Kensington Lock Support

Control	
Button	1 x Power, 3 x function keys

Power			
Battery	Hot-swappable 11.55V, typ. 4558 mAh Li-Polymer Battery (3S2P) Optional 15.4V, typ. 5900 mAh Li-Polymer Battery (4S1P)	Battery Operating Time	Standard. Battery: 8 hours
Power Rating	19V DC	Adapter	100-240V, 50-60Hz / 19V DC

Accessory			
Accessory	Adapter and Power Cord Capacitive Stylus Standard Battery	Optional Accessory	Desk Dock (Optional) Vehicle Dock (Optional) Vehicle Cradle (Optional) Vehicle Charger (Optional) High Capacity Battery (Optional) Hand Strap (Optional) Shoulder Strap (Optional) Carry Bag (Optional)

Barcode Scanner	
Barcode Scanner	1D/2D barcode reader (Optional)

DIMENSIONS UNIT:MM

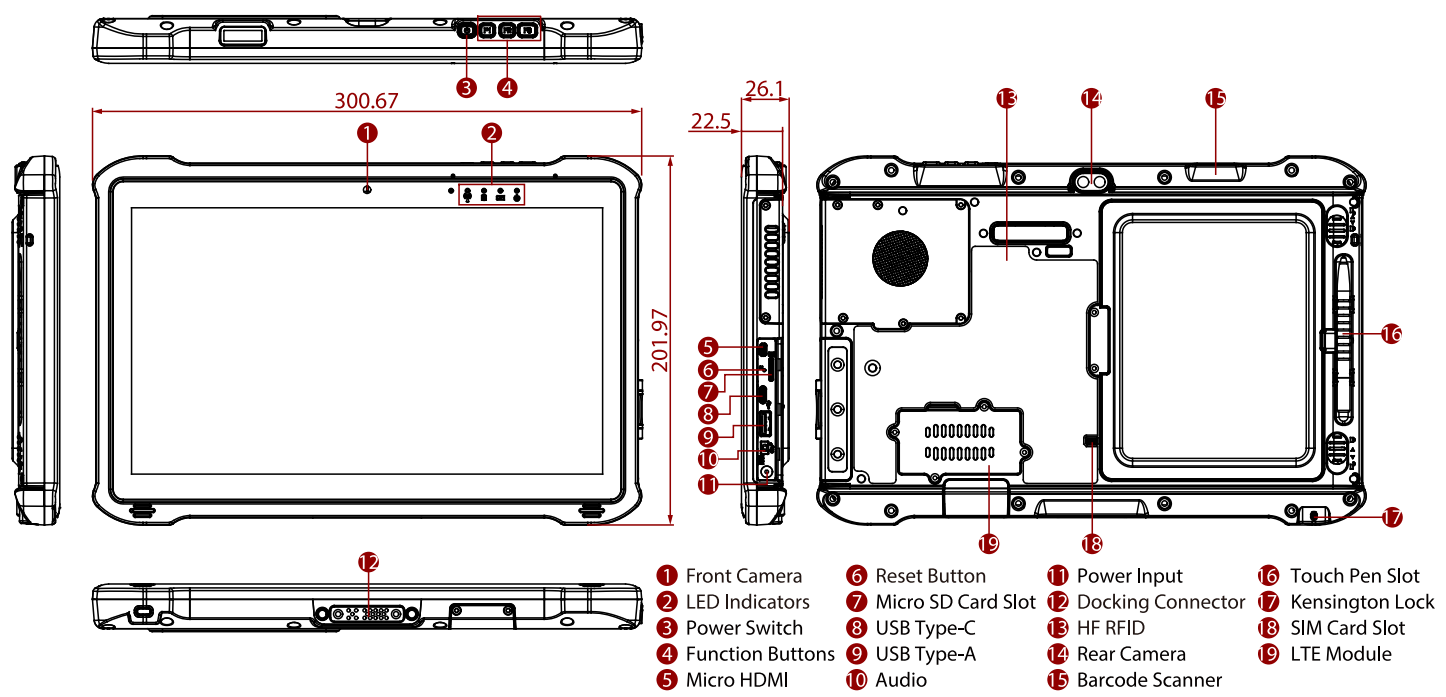

NOTE

- 1.This is a simplified drawing and some components are not marked in detail.
- 2.Please contact our sales representative if you need further product information.
- 3.All specifications are subject to change without prior notice.
- 4.The product shown in this datasheet is a standard model.For diagrams that contain customized or optional I/ O, please contact the Winmate Sales Team for more information.