

Q3

1U Active Air Cooler

PRODUCT SPECIFICATIONS

Model Number: Q3

- Recommend for Intel® CPU as following
 - Support Intel Core 12th -15th Gen, Socket LGA1700/1851
- Active Cooler for 1U Server & Up

Overall Specification

Dimension	92.0 x 90.0 x 28 mm
Weight	444 ± 5 g
Material	Copper Heat Sink with Skiving Fins
Orientations	Switchable without On-board Component Interference
Back Strip Set	Included
Thermal Grease	SHIN-ETSU 7762 or Equivalent
TDP	Up to 125 Watts at 30° ambient temperature

Cooling Fan Specification

Model Number	DB128015BU-PWMG
Dimension	Ø80 x 15 mm
Bearing	Double Ball
Rated Voltage	12V
Rated Speed	At Duty Cycle 0~20%: 1000±200 RPM At Duty Cycle 50%: 3500±10% RPM At Duty Cycle 100%: 7000 RPM
Rated Input Power	At Duty Cycle 0~20%: 0.60 W At Duty Cycle 50%: 3.84 W At Duty Cycle 100%: 19.2 W
Rated Airflow	At Duty Cycle 0~20%: 6.5 CFM At Duty Cycle 50%: 11.2 CFM At Duty Cycle 100%: 22.28 CFM
Rated Static Pressure	At Duty Cycle 0~20%: 2.27 mm-H2O At Duty Cycle 50%: 18.56 mm-H2O At Duty Cycle 100%: 74.18 mm-H2O
Acoustical Noise	At Duty Cycle 0~20%: 21.5 dBA At Duty Cycle 50%: 43.0 dBA At Duty Cycle 100%: 59.14 dBA
Lead Wire Pin Out	Pin#1- Black(-) Pin#2- Yellow(+) Pin#3- Green(Tachometer/ Signal Output) Pin#4- Blue (PWM)

Q3 | Socket LGA 1700

Lead Wire Pin Out Diagram :

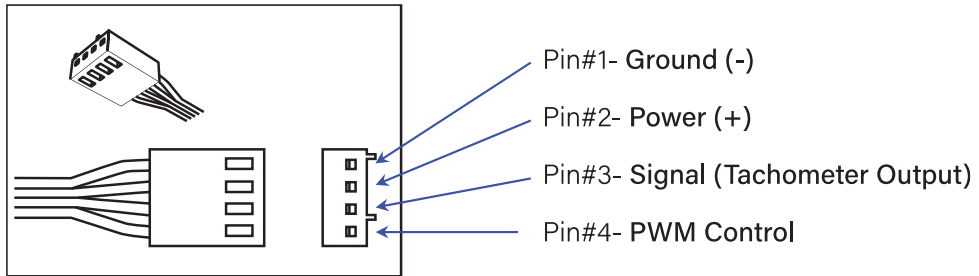

**Performance Chart: Active Cooler Q3 Thermal Resistance
 Thermal Resistance vs. Fan Speed (Duty Cycle and RPM)**

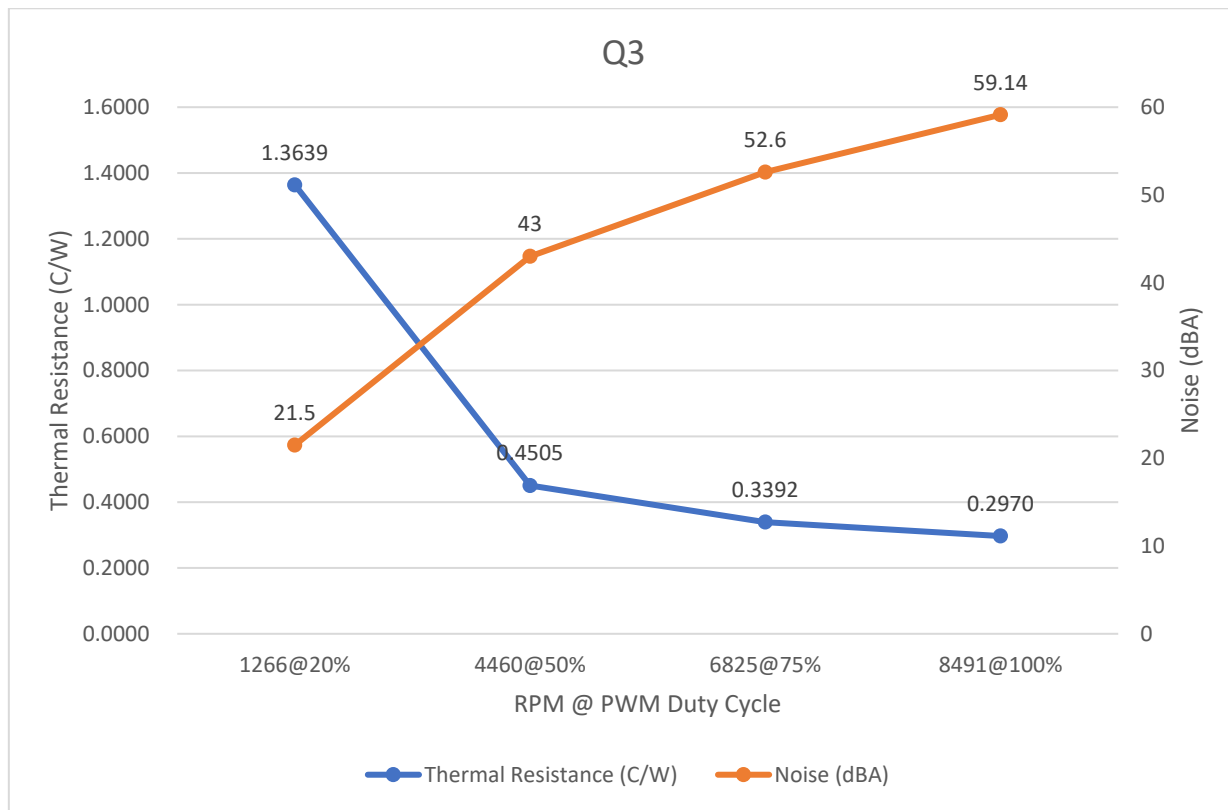

CONFIDENTIAL DOCUMENT

THIS DRAWING CONTAINS INFORMATION PROPRIETARY TO DYNATRON CORPORATION AND DYNAMIN INDUSTRIAL CO., LTD. ANY REPRODUCTION, DISCLOSURE, OR USE OF THIS DRAWING IS EXPRESSLY PROHIBITED EXCEPT AS DYNATRON CORPORATION AND DYNAMIN INDUSTRIAL CO., LTD. MAY OTHERWISE AGREE TO IN WRITING.

REV#	DESCRIPTION	CHECKER	DATE
0.0	INITIAL RELEASE	JOY	02/24/21
1.0	BACKPLATE UPDATE	JOY	10/07/21

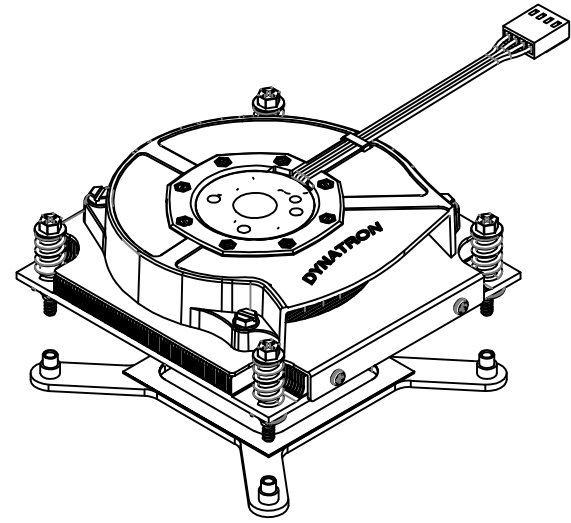
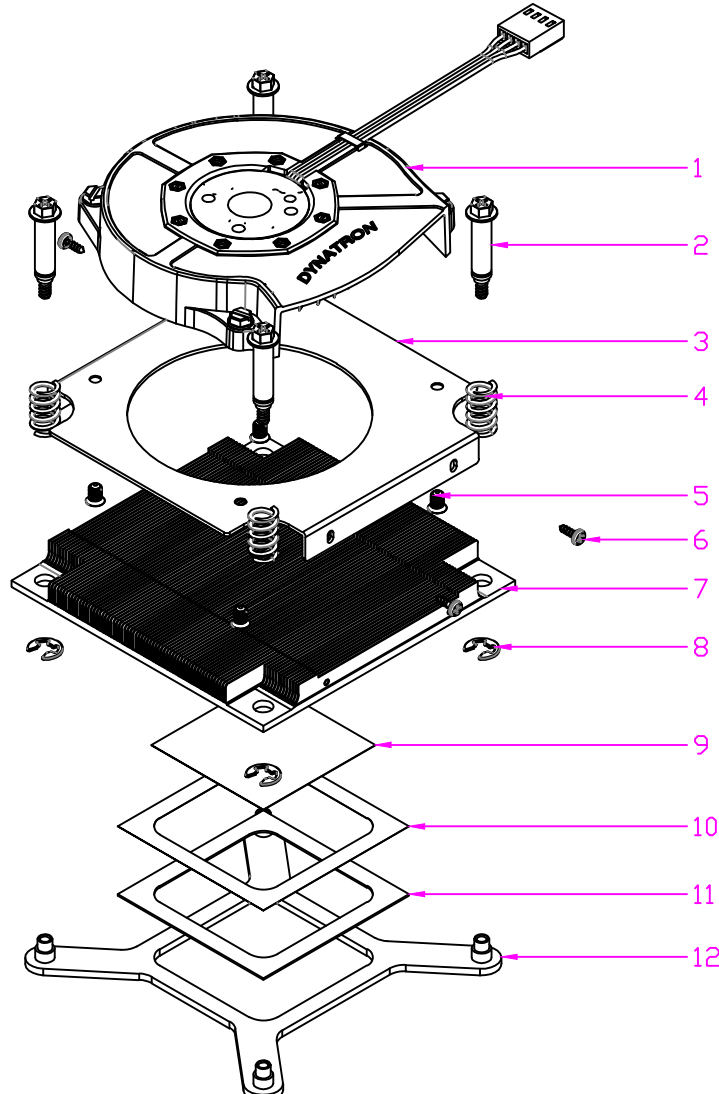

NOTES:
 1. OVERALL DIMENSION: 90.0x90.0x28 mm
 2. THE FIGURE IS FOR REFERENCE ONLY, AND NOT FOR SCALE

12	BACKPLATE	SPCC	1
11	INSULATOR	FORMEX GK-17	1
10	ADHESIVE TAPE	3M	1
9	THERMAL GREASE	SHIN-ETSU 7762	1
8	C-RING	STEEL	4
7	HEATSINK	COPPER 1100	1
6	COVER SCREW	STEEL	4
5	BLOWER SCREW	STEEL	4
4	SPRING	SUS 304	4
3	BLOWER COVER	AL 5052	1
2	HEATSINK SCREW	STEEL	4
1	BLOWER, DB128015BUKAL)-7000RPM	ALUMINUM	1
ITEM #	DESCRIPTION	MATERIAL	QTY.

	DATE	NAME	 DYNATRON CORPORATION
DRAWN	02/24/21	enr.	
CHECKED	02/24/21	Joy	
ENG. APPR.			
MFG. APPR.			
TITLE: 1U Active Cooler Q3 BOM & Exploded Assembly Drawing			DWG. No: DYN-EP-Q3
COMMENTS:			

REV#	DESCRIPTION	CHECKER	DATE
0.0	INITIAL RELEASE	JDY	02/24/21
1.0	BACKPLATE UPDATE	JDY	10/07/21

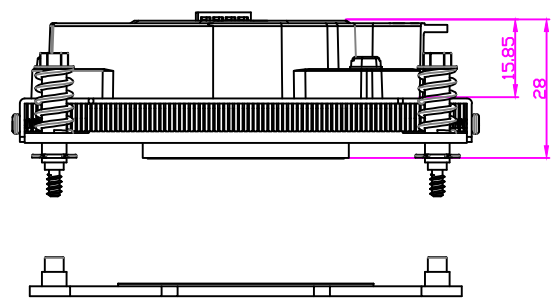
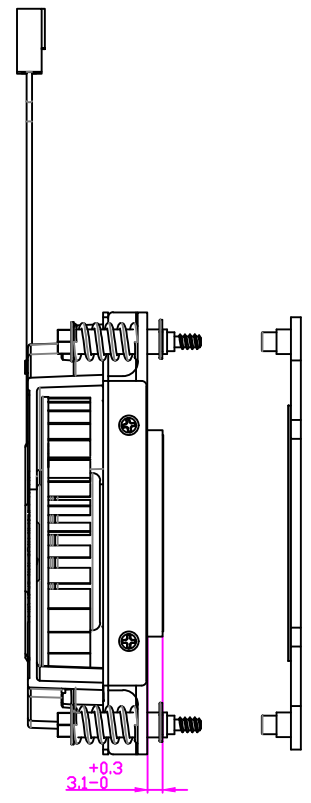
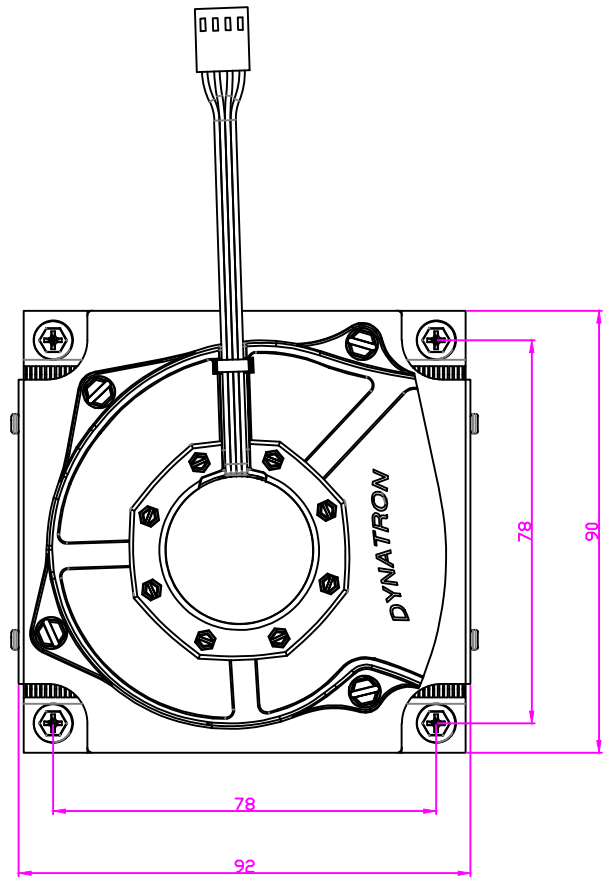

	NAME	DATE
DRAWN BY	ENGR	02/24/2021
CHECKED BY	ENGR	02/24/2021
ENG. APPROVED		
MFG. APPROVED	-	-



DYNATRON CORPORATION

TITLE: 1U ACTIVE COOLER Q3
Overall Dimension Drawing

CONFIDENTIAL DOCUMENT

THIS DRAWING CONTAINS INFORMATION PROPRIETARY TO DYNATRON CORPORATION AND DYNAEON INDUSTRIAL CO., LTD. ANY REPRODUCTION, DISCLOSURE, OR USE OF THIS DRAWING IS EXPRESSLY PROHIBITED EXCEPT AS DYNATRON CORPORATION AND DYNAEON INDUSTRIAL CO., LTD. MAY OTHERWISE AGREE TO IN WRITING.

VIEW	
UNITS	MM

DWG. No: DYN-BD-Q3

REV. 1.0