

M101Q9

10.1" Qualcomm® 6490 Android Rugged Tablet



KEY FEATURES

- 10.1" 1920x1200 LED Panel with PCAP Touch
- Android 13.0
- Qualcomm® 6490 (Octa-core 2.7 GHz)
- Support Wi-Fi 6E
- Optional WWAN 4G and 5G
- MIL-STD-810H Shock / Drop / Vibration Compliant
- Optional Barcode Reader and NFC Reader



SPECIFICATIONS

Display			
Resolution	1920x1200	Size	10.1 inches
Contrast Ratio	800:1	Panel Brightness	800.0 nits
View Angles	85,85,85,85	Bonding	Optical Bonding for Sunlight Viewability
Type	Projected Capacitive Multi Touch	Viewability	Anti-Glare touch treatment
Touch Mode	Support Hand / Gloves and Rain Mode		
System Specification			
Processor	Qualcomm® 6490 (Octa-Core 2.7GHz)	Memory	6GB
Storage	128GB	Operating System	Android 13.0
WLAN	Support	BT	Support
WWAN	4G (Optional) 5G (Optional)	GNSS	GPS/GLONASS
RFID	NFC (Read / Write, Peer to Peer mode) (Optional)	Sensors	Ambient Light Sensor, E-Compass, Gyro, Acceleration Sensors
Camera			
Front Camera	8MP Camera	Rear Camera	16MP Camera with LED Auxiliary Light (Auto Focus)
Mechanical			
Dimension	271.9 x 197.3 x 19.5 mm	Weight	1.2 kg (2.65 lbs) with standard battery, 1.4 kg (3.1 lbs) with optional high capacity battery
Cooling System	Fanless Design		
IO Ports			
USB Port	1 x USB 3.0 Type C OTG (Type C support Power Delivery 20V In) 1 x USB 2.0 Type A	SD Card Slot	1 x Micro SD Card Slot
SIM Card Slot	1 x SIM Card Slot	Audio	1 x Audio Combo connector (Mic in or Line Out) 1 x Built-in Mic 2 x Speaker
Indicator	1 x LED Indicators (Power, Battery)	Docking Connector	1 x Docking Connector
Environment			
Operating Humidity	10% to 90% RH, Non-Condensing	Operating Temperature	-20°C to 60°C
Storage	-30°C to 70°C	Shock	MIL-STD-810H Method 516.8 Procedure I

Temperature			
Vibration	MIL-STD-810H Method 514.8 Procedure I	IP rating	IP65
Drop	MIL-STD-810H Method 516.8, 4 ft		
Certification			
Certification	CE, FCC		
Control			
Button	1 x Volume +/-, 1 x Home Button, 1 x Return Button, 1 x Power Button, 1 x Function Button		
Power			
Battery	7.7V, typ. 5900 mAh LiPolymer Battery (2S1P) 7.4V, typ. 10280 mAh LiPolymer Battery (2S2P) (Optional) Warm swappable function (Optional)	Battery Operating Time	8Hr
Power Rating	19V	Adapter	19V 3.42A Adapter
Security Function			
SOTI MobiControl	SOTI MobiControl Compliance	Kensington Lock	Kensington Lock
Accessory			
Accessory	Adapter and Power Cord Standard Battery Capacitive Stylus	Optional Accessory	Desk Dock Vehicle Dock (without VGA output) Vehicle Cradle Battery Charger Hand Strap VESA Mount Kit Shoulder Strap Carry Bag Vehicle Charger Micro SD Card HDMI Adapter

Barcode Scanner			
Barcode Scanner	1D/2D Barcode Reader (Optional)		

DIMENSIONS UNIT:MM

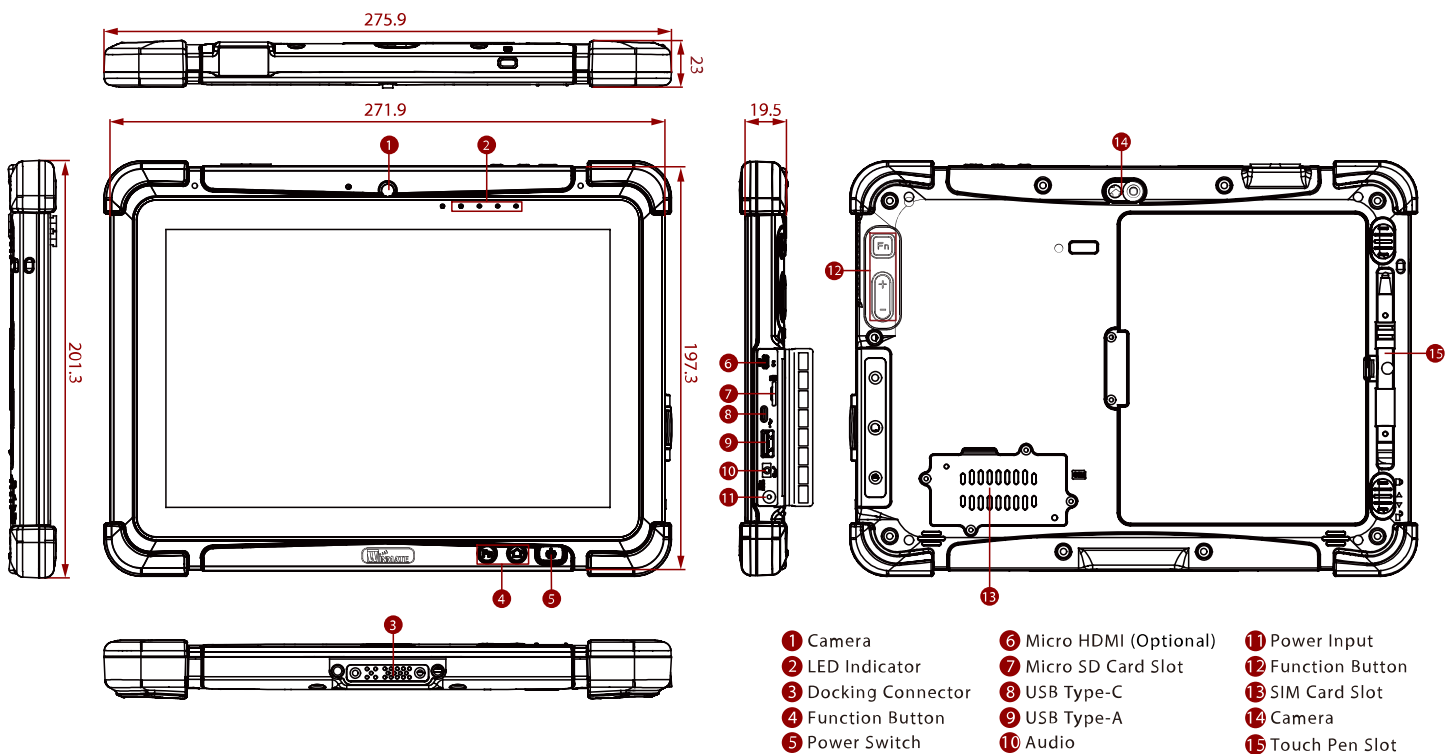

NOTE

1. Total usable memory will be less dependent upon actual system configuration.
2. Length measurements do not include protrusions. Weight varies with options.
3. Measured at dimming LCD brightness. Varies depending on the usage conditions.
4. Accessories may vary depending on your configuration.
5. This is a simplified drawing and some components are not marked in detail.
6. The product shown in this datasheet is a standard model. For diagrams that contain customized or optional I/O, please contact the Winmate Sales Team for more information