

M156AD

15.6" Windows Rugged Tablet PC with Intel® Core™ i5-1235U



KEY FEATURES

- 12th generation Intel® Processor Family - Alder Lake Processor
- 15.6" FHD Panel resolution with PCAP touch
- Sunlight readable with antiglare solution
- Hot-swappable battery design
- USB TypeC port support PD 3.0 and ALT mode
- Integrated GigaLAN Port
- MIL-STD-461G and MIL-STD-810H Compliant
- IP65 waterproof and dustproof



SPECIFICATIONS

Display			
Bonding	Optical Bonding for Sunlight Viewability	Type	Projected Capacitive Multi Touch
Resolution	1920x1080	Size	15.6 inches
Contrast Ratio	800:1	Panel Brightness	800.0 nits
View Angles	85,85,85,85		
System Specification			
Processor	Intel Core i5-1235U (up to 4.4GHz)	Memory	8GB DDR5 SDRAM 16GB DDR5 SDRAM (Optional) 32GB DDR5 SDRAM 2nd Memory available with up to 32+32GB DDR5 SDRAM (Optional)
Storage	256GB M.2 NVMe SSD 512GB M.2 NVMe SSD (Optional) 1TB M.2 NVMe SSD (Optional) 2TB M.2 NVMe SSD (Optional) 2nd storage available with up to 2TB M.2 NVMe SSD (Optional)	Security	Trusted Platform Module (TPM) 2.0 Kensington Lock
Operating System	Windows 10 IoT Enterprise LTSC (64 bit) Windows 11 IoT Enterprise LTSC (64 bit) (Optional)	WLAN	Support
BT	Support	WWAN	4G LTE (Optional) 5G (Optional)
RFID	HF RFID reader 13.56 MHz (Optional)	Sensors	Light sensor/ G-sensor / Gyro
Camera			
Front Camera	2MP Front Camera	Rear Camera	8MP Rear Camera with auto-focus and LED light
Mechanical			
Dimension	387.7 x 256.1 x 27.5 mm	Weight	2.8kg
Cooling System	Fan Design		
IO Ports			
USB Port	3 x USB 3.0 (Type A), 1 x USB 3.0 (Type C)	SD Card Slot	1 x Micro SDXC Slot
SIM Card Slot	1 x Nano SIM card slot	Video	2 x HDMI 4K Output (Optional)
Audio	1 x Audio combo 3.5mm audio combo jack Dual Digital Mic With Noise Cancellation Dual Speaker	LAN	2 x RJ45-10/100/1000 GigaLAN port
Indicator	2x LED Indicator for Power, Battery	Docking Connector	1 x 19-pin docking connector

Environment			
Operating Humidity	10% to 90% RH, non-condensing	Operating Temperature	-20°C to 60°C
Storage Temperature	-30°C to 70°C	Shock	MIL-STD-810H Method 516.8 Procedure I
Vibration	MIL-STD-810H Method 514.8 Procedure I	IP rating	IP65
Drop	MIL-STD-810H Method 516.8, 3 ft	EMC	MIL-STD-461G CE101, CE102, RE101, RE102, CS118 (Default) MIL-STD-461G CS101, CS114, CS115, CS116, RS101, RS103 (Optional)
Certification			
Certification	CE, FCC		
Security Function			
SOTI MobiControl	SOTI MobiControl Compliance	Kensington Lock	Kensington Lock Support
Control			
Button	1 x Power, 3 x Programmable Function Keys		
Power			
Battery	Hotswappable 2 x 11.55V typ. 3220 mAh Lilon Battery (3S1P)	Battery Operating Time	Standard. Battery: 11 hours
Power Rating	19V DC	Adapter	100-240V, 50-60Hz, 120W / 19V DC
Accessory			
Accessory	Adapter and Power Cord Capacitive Stylus Standard Battery	Optional Accessory	Spare Battery (Optional) Battery Charger (Optional) Handle (Optional)

DIMENSIONS UNIT:MM

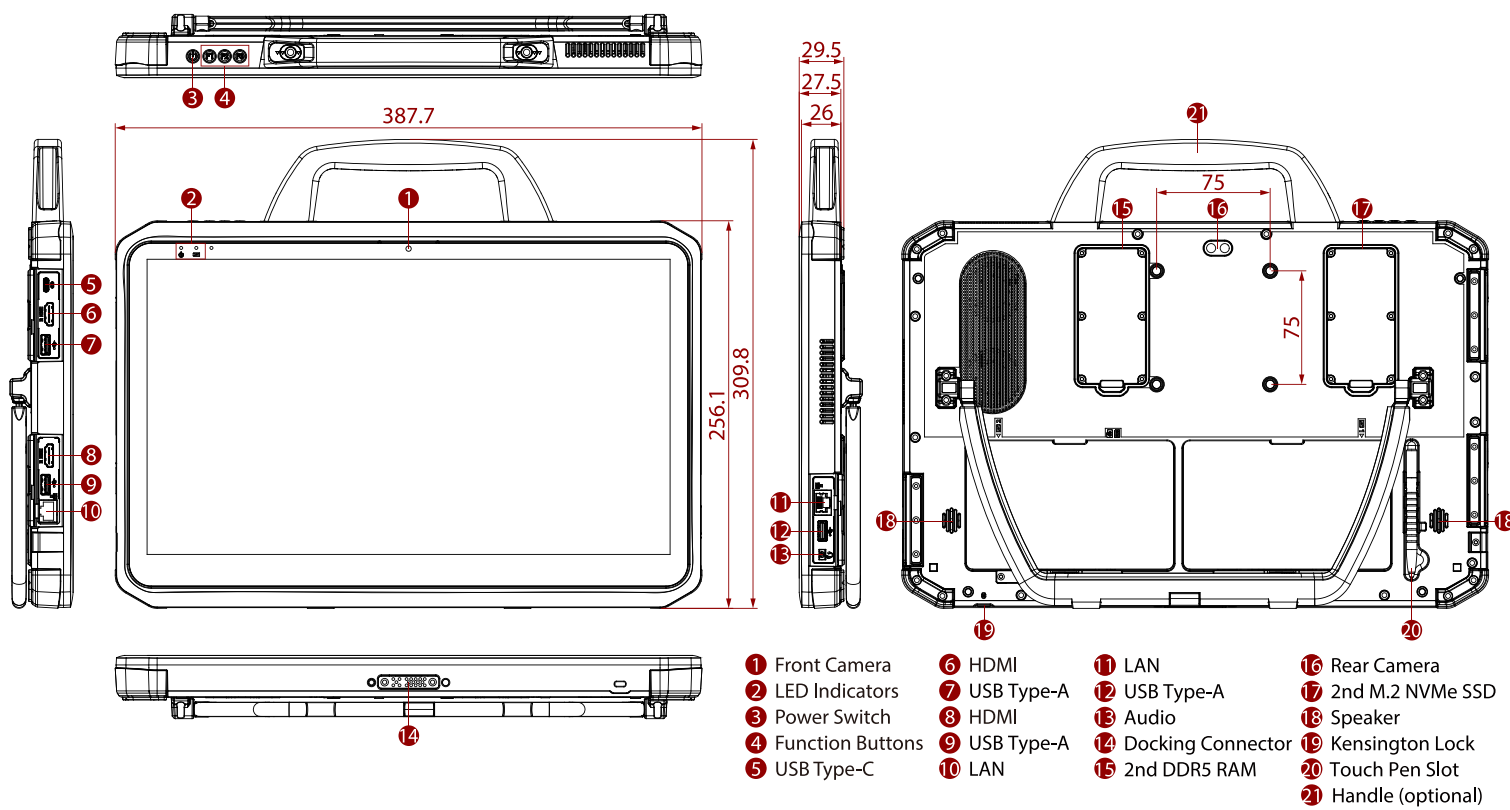

NOTE

- 1.This is a simplified drawing and some components are not marked in detail.
- 2.Please contact our sales representative if you need further product information.
- 3.All specifications are subject to change without prior notice.
- 4.The product shown in this datasheet is a standard model.For diagrams that contain customized or optional I/ O, please contact the Winmate Sales Team for more information.

