

# AIMB-278 B1

## Mini-ITX Motherboard 12th/13th/14th Gen Intel® Core™ Processor LGA1700

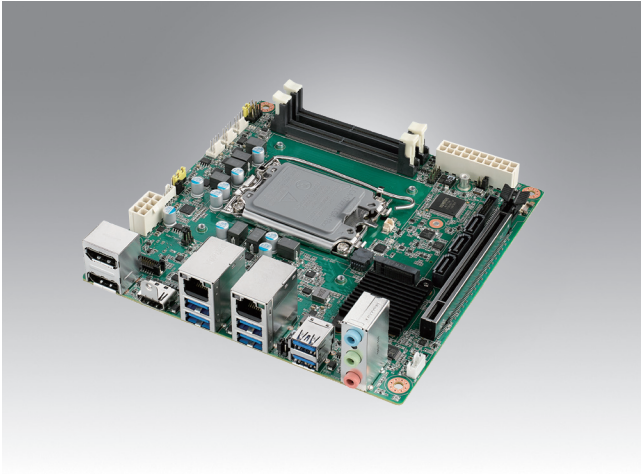

### Features

- 12th/13th/14th Gen Intel® Core™ Desktop Processors, Up to 24Core, support Q670E/H610E chipset
- Dual channel DDR5 5600MHz, max. 96GB with two SODIMMs
- Super Speed I/O: PCIe x16 Gen5 (32GT/s), USB3.2 Gen2 (10Gbps), 2.5GbE
- Quad independent 4K displays with 2 DP, 1 HDMI, 1eDP
- Rich expansion: M.2 M key for NVMe SSD, M.2 E key for wireless, 3 SATA(RAID 0,1,5)
- TPM2.0 support
- SUSI API, WISE-DeviceOn and Embedded Software



### Specifications

	CPU	i9-14900	i9-14900T	i7-14700	i7-14700T	i5-14500	i5-14500T	i5-14400	i5-14400T	i3-14100	i3-14100T		
14th Generation Processors	CPU	i9-14900	i9-14900T	i7-14700	i7-14700T	i5-14500	i5-14500T	i5-14400	i5-14400T	i3-14100	i3-14100T		
	Core Number	24	24	20	20	14	14	10	10	8	8		
	Base frequency (GHz)	2.0/1.5	1.1/0.8	2.1/1.5	1.3/0.9	2.6/1.9	1.7/1.2	2.5/1.8	1.5/1.1	3.5/NA	2.7/NA		
	Max Speed (GHz)	5.8/4.3	5.5/4.0	5.4/4.2	5.2/3.7	5.0/3.7	4.8/3.4	4.7/3.5	4.5/3.2	4.7/NA	4.4/NA		
	Smart cache (MB)	36MB	36MB	33MB	33MB	24MB	24MB	20MB	20MB	12MB	12MB		
	TDP (W)	65W	35W	65W	35W	65W	35W	65W	35W	65W	35W		
13th Generation Processors	CPU	i9-13900E / i9-13900	i9-13900TE	i7-13700E / i7-13700	i7-13700TE	i5-13500E / i5-13500	i5-13500TE	i5-13400E / i5-13400	i3-13100E / i3-13100	i3-13100TE			
	Core Number	24	24	16	16	14	14	10	4	4			
	Base frequency (GHz)	1.8/2.0	1	1.9/2.1	0.8	2.4/2.6	1.3	2.4/2.5	3.3/3.4	2.4			
	Max Speed (GHz)	5.2/5.6	5	5.1/5.2	4.8	4.6/4.8	4.5	4.6	4.4/4.5	4.1			
	Smart cache (MB)	36	36	30	30	24	24	20	12	12			
	TDP (W)	65	35	65	35	65	35	65	60	35			
12th Generation Processors	CPU	i9-12900E / i9-12900	i9-12900TE	i7-12700E / i7-12700	i7-12700TE	i5-12500E / i5-12500/12400	i5-12500TE	i3-12100E / i3-12100	i3-12100TE	G7400E	G7400TE	G6900E	G6900TE
	Core Number	16	16	12	12	6	6	4	4	2	2	2	2
	Base frequency (GHz)	2.3/2.4	1.1	2.1	1.4	2.9/3.0/2.5	1.9	3.2	2.1	3.6	3	3	2.4
	Max Speed (GHz)	5	4.8	4.8	4.7	4.5/4.6/4.4	4.3	4.2/4.3	4	NA	NA	NA	NA
	Smart cache (MB)	30	30	25	25	18	18	12	12	6	6	4	4
	TDP (W)	65	35	65	35	65	35	60	35	46	35	46	35
Processor System	Chipset	Q670E / H610E											
	BIOS	AMI EFI 256Mb SPI											
Expansion Slot	M.2	1 M-Key for SSD, 1 E-Key for Wireless connection											
	PCIe x16	PCIe x16 Gen5(32GT/s) for discrete GPU card and storage devices											
Memory	Technology	Dual Channel DDR5, up to 5600 MHz (non-ECC)											
	Max. Capacity	96GB (up to 48GB per SODIMM)											
	Socket	2 x 262pin SODIMM											
Graphics	Controller	up to Intel® UHD Graphics 770											
	HDMI	HDMI2.0b, supports max. resolution 4096 x 2160 @ 60 Hz											
	DP	DP1.4a, supports max. resolution 4096 x 2304 @ 60 Hz											
	eDP	By Default, with internal pin header, supports max. resolution 4096 x 2304 @ 60 Hz											
	LVDS	By Option, internal pin header, supports single/dual channel 18/24-bit with maximum resolution up to 1920 x 1200 @ 60 Hz (eDP colay with LVDS)											
	Multi Displays	up to 4 independent displays (combination of 2DP, 1HDMI, 1eDP)											
Network	ETHERNET	up to 2500 Mb/s											
	Controller	Intel I219LM and Intel i226											
	Connector	2 x RJ45											
SATA	Max data transfer rate	600 MB/s											
	Channel	3 x SATAIII											
Rear I/O	DP	2											
	HDMI	1											
	Ethernet	2											
	USB	Up to 6 USB3.2 (Q670E: 6 USB3.2 Gen2; H610E: 2 USB3.2 Gen1 (optional 2 USB3.2 Gen1) & 2 USB2.0)											
	Audio	1 (default with Line out/Mic in) (Line in option)											
Internal Connector	USB	2 USB2.0											
	eDP/LVDS	1 eDP (LVDS colay with eDP)											
	Serial	2 (COM1 RS-232, COM2 RS232/422/485)											
	SATA	3											
	M.2	1 M-key (dimension: 2280) 1 E-key (dimension: 2230)											
	GPIO	6-bit											
Watchdog Timer	Output	System reset											
	Interval	Programmable 1 ~ 255 sec/min											
Power Requirements	Boost	92.7W											
	Typical	68.9W											
Environment	Temperature	Operating: 0 ~ 60° C (32 ~ 140° F), depends on CPU speed and cooler solution											
	Storage	Non-Operating: -40 ~ 85° C (-40 ~ 185° F)											
Physical Characteristics	Dimensions	170 mm x 170 mm (6.69" x 6.69")											

## Block Diagram

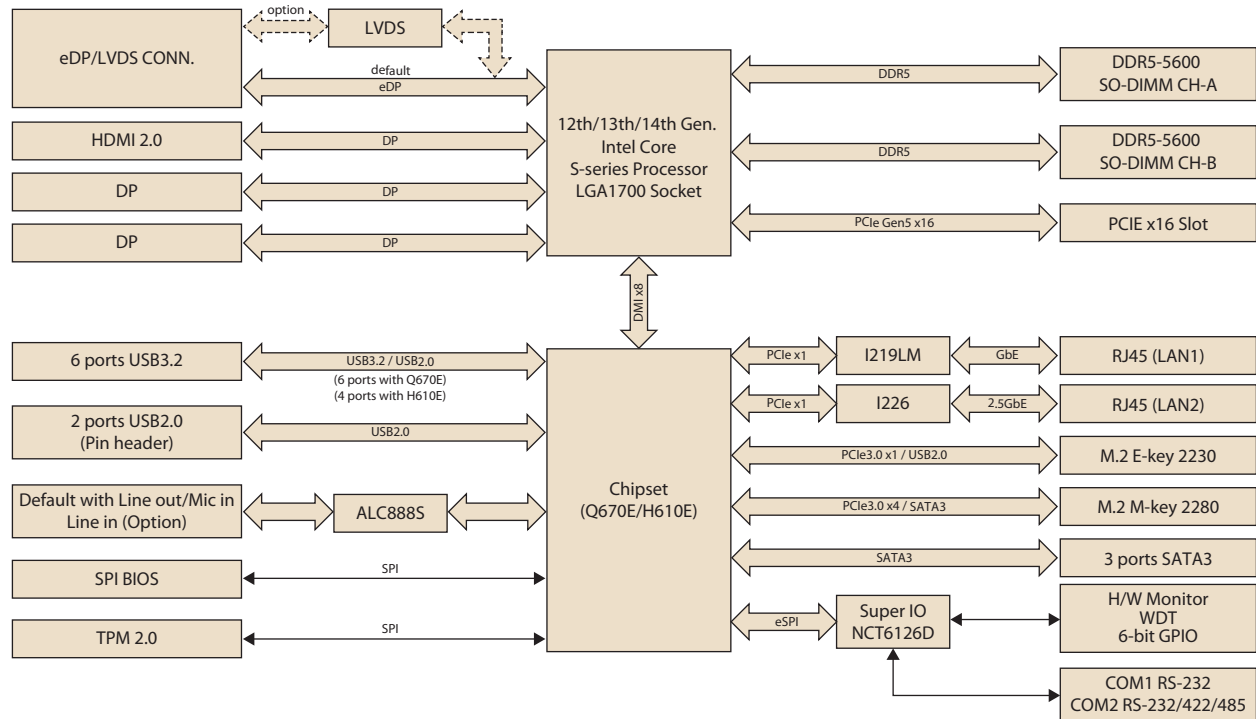

## Ordering Information

P/N	Chipset	HDMI	LVDS/eDP	DP	GbE	2.5GbE	COM	SATAIII	USB3.2	USB2.0	M.2 M key	M.2 E key	PCIex16	TPM	AMP
AIMB-278Q-EAB1	Q670E	1	(1)/1	2	1	1	2	3	6	2	1	1	1	1	1
AIMB-278Q-LAB1	Q670E	1	1/(1)	2	1	1	2	3	6	2	1	1	1	1	1
AIMB-278H-EAB1	H610E	(1)	(1)/1	2	1	(1)	2	2	2/(2)	4	1	1	1	(1)	(1)

\*() Supports by BOM options

## Packing List

Part Number	Description	Quantity
1700003194	SATA HDD cable	1
1700031130-01	1-to-2 serial port cable, 20cm	1
1960109548T001	I/O port bracket	1
2046027800	Startup manual for AIMB-278	1

## Optional Accessory

Part Number	Description
1700029719-01	M cable USB-A 9P(F)x2/2x10P-2.0 30CM USB3.0
1970005349T001	LGA1700 CPU Cooler H: 55.4mm (for TDP 65W)
1970005672T001	LGA1700 CPU Cooler H: 32mm (for TDP 35W)

## I/O View



## Embedded OS/API

OS/API	Part No.	968 P/N	Description
Windows 10	20706WX1ES0015	968QW21ELE	img W10 21EL AIMB-278 64b 21H2 ENU
Windows 10	20706WX1HS0015	968QW21HLE	img W10 21HL AIMB-278 64b 21H2 ENU
Windows 10	20706WX1VS0015	968QW21VLE	img W10 21VL AIMB-278 64b 21H2 ENU
Ubuntu22.04	20706U22DS0017	968MOU204D	img Ubuntu AIMB-278 64b 22.04 ENU

## Optional Chassis

Part Number	Description
EPC-B2000-A030	Mini-ITX Chassis with 350W ATX power supply