

SATADOM-ML

3SE3 Series

Customer: _____

Customer

Part

Number: _____

Innodisk

Part

Number: _____

Innodisk

Model Name: _____

Date: _____

Innodisk Approver	Customer Approver

**Total Solution For
Industrial Flash Storage**

Table of contents

LIST OF FIGURES	6
1. PRODUCT OVERVIEW	7
1.1 INTRODUCTION OF INNODISK SATADOM-ML 3SE3	7
1.2 PRODUCT VIEW AND MODELS	7
1.3 SATA INTERFACE	7
2. PRODUCT SPECIFICATIONS	8
2.1 CAPACITY AND DEVICE PARAMETERS	8
2.2 PERFORMANCE	8
2.3 ELECTRICAL SPECIFICATIONS	8
2.3.1 Power Requirement	8
2.3.2 Power Consumption	9
2.4 ENVIRONMENTAL SPECIFICATIONS	9
2.4.1 Temperature Ranges	9
2.4.2 Humidity	9
2.4.3 Shock and Vibration	9
2.4.4 Mean Time between Failures (MTBF)	9
2.5 CE AND FCC COMPATIBILITY	9
2.6 RoHS COMPLIANCE	10
2.8 TRANSFER MODE	10
2.9 PIN ASSIGNMENT	11
2.10 MECHANICAL DIMENSIONS	11
2.11 ASSEMBLY WEIGHT	11
2.12 SEEK TIME	12
2.13 HOT PLUG	12
2.14 NAND FLASH MEMORY	12
3. THEORY OF OPERATION	13
3.1 OVERVIEW	13
3.2 SATA III CONTROLLER	13
3.3 ERROR DETECTION AND CORRECTION	14
3.4 WEAR-LEVELING	14
3.5 BAD BLOCKS MANAGEMENT	14
3.6 iDATA GUARD	14
3.7 GARBAGE COLLECTION	14
4. INSTALLATION REQUIREMENTS	15
4.1 SATADOM-ML 3SE3 PIN DIRECTIONS	15
4.2 ELECTRICAL CONNECTIONS FOR SATADOM-ML 3SE3	15

4.3 DEVICE DRIVE	15
4.4 POWER SUPPLY FOR SATDOM	15
4.4.1 Power cable.....	15
4.4.2 Pin8 and Pin7 VCC.....	16
4.5 WRITE PROTECTION	17
5. PART NUMBER RULE	18

REVISION HISTORY

Revision	Description	Date
Preliminary	First Released	Mar., 2017
Rev. 1.0	Updated Info: Performance, Power Consumption, Part Number rule and RoHS	May., 2017
Rev. 1.1	Update RoHS and REACH	Aug., 2017
Rev. 1.2	Update Product Photo & Mechanical Drawing	Apr., 2024
Rev. 1.3	Update Reliability	Aug., 2024

List of Tables

TABLE 1: DEVICE PARAMETERS	8
TABLE 2: PERFORMANCE	8
TABLE 3: INNODISK SATADOM-ML 3SE3 POWER REQUIREMENT	8
TABLE 4: POWER CONSUMPTION	9
TABLE 5: TEMPERATURE RANGE FOR SATADOM-ML 3SE3	9
TABLE 6: SHOCK/VIBRATION TESTING FOR SATADOM-ML 3SE3	9
TABLE 7: SATADOM-ML 3SE3 MTBF	9
TABLE 8: INNODISK SATADOM-ML 3SE3 PIN ASSIGNMENT	11

List of Figures

FIGURE 1: INNODISK SATADOM-ML 3SE3	7
FIGURE 2: INNODISK SATADOM-ML 3SE3 MECHANICAL DIAGRAM	11
FIGURE 3: INNODISK SATADOM-ML 3SE3 BLOCK DIAGRAM	13
FIGURE 4: SIGNAL SEGMENT AND POWER SEGMENT	15
FIGURE 5: STANDARD POWER CABLE	15
FIGURE 6: PIN 8 / PIN 7 HOST DESIGN IN REFERENCE CIRCUIT	16
FIGURE 7: HARDWARE WRITE PROTECT POSITION	17

1. Product Overview

1.1 Introduction of Innodisk SATADOM-ML 3SE3

Innodisk Serial ATA Disk on Module (SATADOM) supports SATA III standard (6.0Gb/s) interface with excellent performance, and SATADOM-ML 3SE3 is designed as the smallest form factor size that could enhance compatibility with various design applications.

Innodisk's patented Pin7 and Pin 8 SATA power supply technologies use the SATA connector itself as a power supply to drive the device without external power cables. It is a 100% cable-less, shock resistant, space saving and plug-and-play storage solution that optimizes airflow and makes the best use of limited board space in embedded and rackmount server systems.

Innodisk SATADOM-ML 3SE3 effectively reduces the booting time of operation system and the power consumption is less than hard disk drive (HDD), and complies with ATA protocol, no additional drives are required, and can be configured as a boot device or data storage device.

1.2 Product View and Models

Innodisk SATADOM-ML 3SE3 is available in follow capacities within SLC flash ICs.

[SATADOM-ML 3SE3 4GB](#)

[SATADOM-ML 3SE3 8GB](#)

[SATADOM-ML 3SE3 16GB](#)

[SATADOM-ML 3SE3 32GB](#)

[SATADOM-ML 3SE3 64GB](#)



Figure 1: Innodisk SATADOM-ML 3SE3

1.3 SATA Interface

Innodisk SATADOM-ML 3SE3 supports SATA III interface, and compliant with SATA I and SATA II.

2. Product Specifications

2.1 Capacity and Device Parameters

SATADOM-ML 3SE3 device parameters are shown in Table 1.

Table 1: Device parameters

Capacity	LBA	Cylinders	Heads	Sectors	User Capacity(MB)
4GB	7835184	7773	16	63	3825
8GB	15649200	15525	16	63	7641
16GB	31277232	16383	16	63	15272
32GB	62533296	16383	16	63	30533
64GB	125045424	16383	16	63	61057

2.2 Performance

Burst Transfer Rate: 6.0Gbps

Table 2: Performance

Capacity	4GB	8GB	16GB	32GB	64GB
Sequential* Read (max.)	180 MB/s	350 MB/s	350 MB/s	400 MB/s	400 MB/s
Sequential* Write (max.)	60 MB/s	110 MB/s	120 MB/s	200 MB/s	200 MB/s
4KB Random** Read (QD32)	8,800 IOPS	12,500 IOPS	12,500 IOPS	13,300 IOPS	13,300 IOPS
4KB Random** Write (QD32)	9,200 IOPS	11,500 IOPS	12,500 IOPS	19,000 IOPS	19,000 IOPS

Note: * Sequential performance is based on CrystalDiskMark 5.1.2 with file size 1000MB

** Random performance is based on IO meter with Queue Depth 32

2.3 Electrical Specifications

2.3.1 Power Requirement

Table 3: Innodisk SATADOM-ML 3SE3 Power Requirement

Item	Symbol	Rating	Unit
Input voltage	V _{IN}	+5 DC +- 5%	V

2.3.2 Power Consumption

Table 4: Power Consumption

Mode	Power Consumption (mA)
Read	190 (max.)
Write	220 (max.)
Idle	100 (max.)
Peak Current*	350 (max.)

*To design in Pin7/8 VCC on motherboard, 5V with 1A power supply is requested.

2.4 Environmental Specifications

2.4.1 Temperature Ranges

Table 5: Temperature range for SATADOM-ML 3SE3

Temperature	Range
Operating	Standard Grade: 0°C to +70°C
	Industrial Grade: -40°C to +85°C
Storage	-55°C to +95°C

2.4.2 Humidity

Relative Humidity: 10-95%, non-condensing

2.4.3 Shock and Vibration

Table 6: Shock/Vibration Testing for SATADOM-ML 3SE3

Reliability	Test Conditions	Reference Standards
Vibration	7 Hz to 2K Hz, 20G, 3 axes	IEC 60068-2-6
Mechanical Shock	Duration: 0.5ms, 1500 G, 3 axes	IEC 60068-2-27

2.4.4 Mean Time between Failures (MTBF)

Table 7 summarizes the MTBF prediction results for various SATADOM-ML 3SE3 configurations. The analysis was performed using a RAM Commander™ failure rate prediction.

- **Failure Rate:** The total number of failures within an item population, divided by the total number of life units expended by that population, during a particular measurement interval under stated condition.
- **Mean Time between Failures (MTBF):** A basic measure of reliability for repairable items: The mean number of life units during which all parts of the item perform within their specified limits, during a particular measurement interval under stated conditions.

Table 7: SATADOM-ML 3SE3 MTBF

Product	Condition	MTBF (Hours)
Innodisk SATADOM-ML 3SE3	Telcordia SR-332 GB, 25°C	>3,000,000

2.5 CE and FCC Compatibility

SATADOM-ML 3SE3 conforms to CE and FCC requirements.

2.6 RoHS Compliance

SATADOM-ML 3SE3 is fully compliant with RoHS directive.

2.7 Reliability

Parameter	Value
Read Cycles	Unlimited Read Cycles
Flash Endurance	60,000 P/E cycles
Wear-Leveling Algorithm	Support
Bad Blocks Management	Support
Error Correct Code	Support
Data Retention	Under 40°C: 1 Year at NAND Life End
TBW* (Total Bytes Written)	Unit: TB
4GB	23.43
8GB	46.87
16GB	93.75
32GB	187.5
64GB	375
* Total bytes written is based on JEDEC 218 (Solid-State Drive Requirements and Endurance Test Method)	
** Lifespan is calculated by device written per day	

2.8 Transfer Mode

SATADOM-ML 3SE3 support following transfer mode:

Serial ATA I 1.5Gbps

Serial ATA II 3.0Gbps

Serial ATA III 6.0Gbps

2.9 Pin Assignment

Innodisk SATADOM-ML 3SE3 uses a standard SATA pin-out. See Table 8 for SATADOM-ML 3SE3 pin assignment.

Table 8: Innodisk SATADOM-ML 3SE3 Pin Assignment

Name	Type	Description
Pin 0	GND	Shielding
Pin 1	GND	Shielding
Pin 2	A+	Differential signal to A
Pin 3	A-	Differential signal to A-
Pin 4	GND	Shielding
Pin 5	B-	Differential signal to B-
Pin 6	B+	Differential signal to B
Pin 7	GND/ Vcc*	Shielding/ +5V Power*
Pin 8	VCC	+5V Power

*** SATADOM-ML 3SE3 default power supply through pin 8 or extra power cable.**

Pin 7 power supply as an optional function with separated PN end of B.

2.10 Mechanical Dimensions

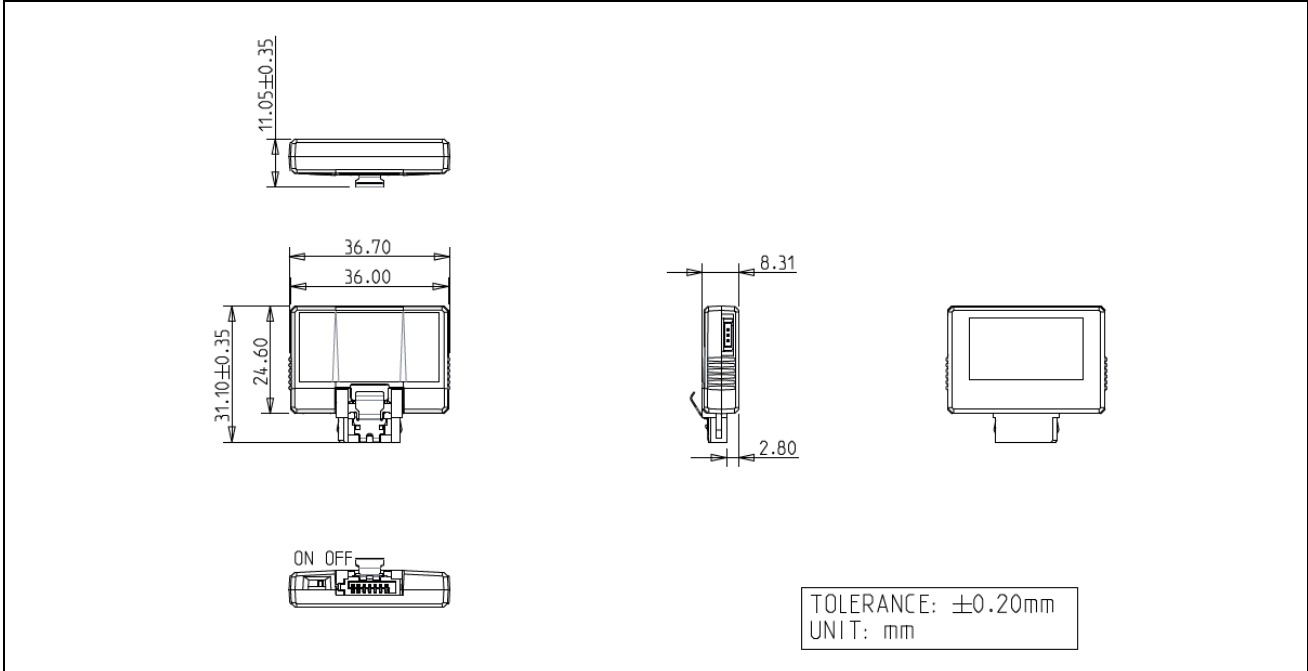

Figure 2: Innodisk SATADOM-ML 3SE3 mechanical diagram

2.11 Assembly Weight

An Innodisk SATADOM-ML 3SE3 within flash ICs, 32GB's weight is 7 grams approximately.

2.12 Seek Time

Innodisk SATADOM-ML 3SE3 is not a magnetic rotating design. There is no seek or rotational latency required.

2.13 Hot Plug

The SSD support hot plug function and can be removed or plugged-in during operation. User has to avoid hot plugging the SSD which is configured as boot device and installed operation system.

Surprise hot plug : The insertion of a SATA device into a backplane (combine signal and power) that has power present. The device powers up and initiates an OOB sequence.

Surprise hot removal: The removal of a SATA device from a powered backplane, without first being placed in a quiescent state.

2.14 NAND Flash Memory

Innodisk SATADOM-ML 3SE3 uses Single Level Cell (SLC) NAND flash memory, which is non-volatility, high reliability and high speed memory storage. Each cell stores 1 bits or holds four states per cell. Read or Write data to flash memory for SSD is control by microprocessor.

3. Theory of Operation

3.1 Overview

Figure 2 shows the operation of Innodisk SATADOM-ML 3SE3 from the system level, including the major hardware blocks.

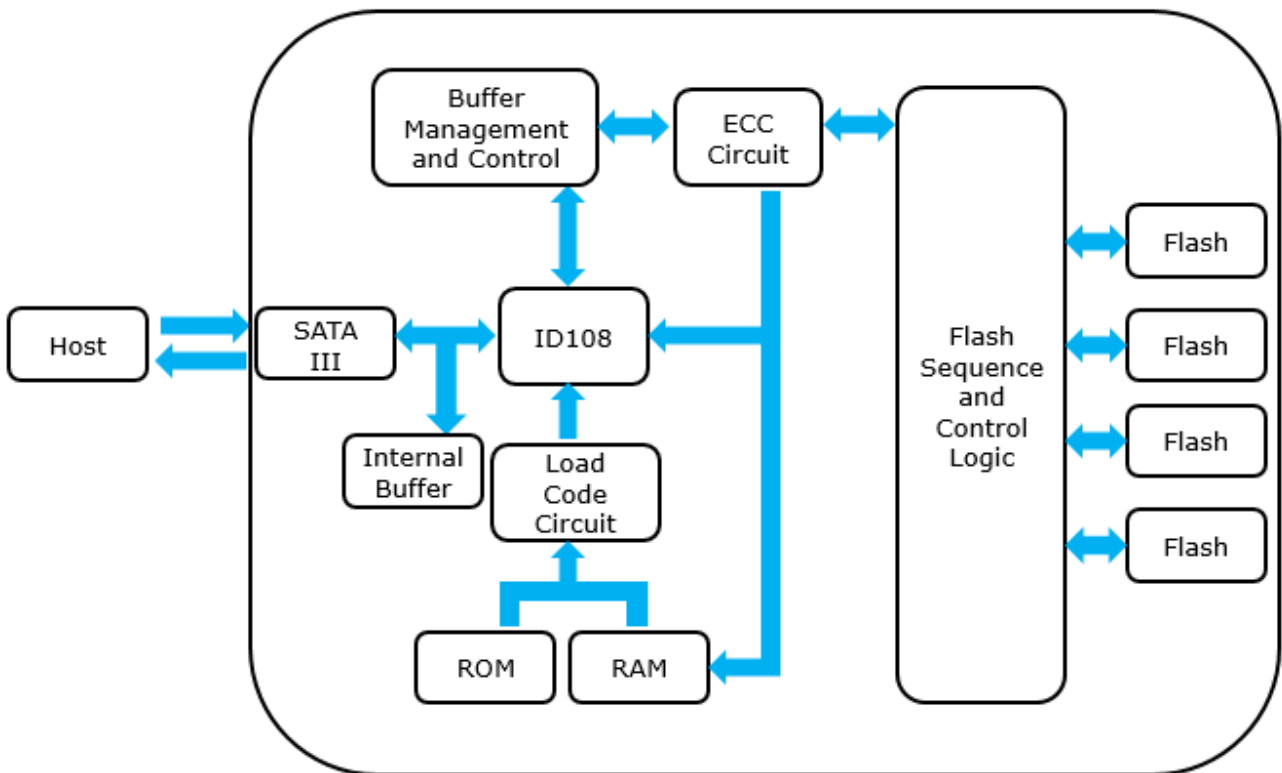

Figure 3: Innodisk SATADOM-ML 3SE3 Block Diagram

Innodisk SATADOM-ML 3SE3 integrates a SATA III controller and NAND flash memories. Communication with the host occurs through the host interface, using the standard ATA protocol. Communication with the flash device(s) occurs through the flash interface.

3.2 SATA III Controller

Innodisk SATADOM-ML 3SE3 is designed with ID 108, a SATA III 6.0Gbps (Gen. 3) controller. The Serial ATA physical, link and transport layers are compliant with Serial ATA Gen 1, Gen 2 and Gen 3 specification (Gen 3 supports 1.5Gbps/3.0Gbps/6.0Gbps data rate). The controller has 2 channels for flash interface.

3.3 Error Detection and Correction

Highly sophisticated Error Correction Code algorithms are implemented. The ECC unit consists of the Parity Unit (parity-byte generation) and the Syndrome Unit (syndrome-byte computation). This unit implements an algorithm that can correct 40 bits per 1024 bytes in an ECC block. Code-byte generation during write operations, as well as error detection during read operation, is implemented on the fly without any speed penalties.

3.4 Wear-Leveling

Flash memory can be erased within a limited number of times. This number is called the erase cycle limit or write endurance limit and is defined by the flash array vendor. The erase cycle limit applies to each individual erase block in the flash device.

Innodisk SATADOM-ML 3SE3 uses a static wear-leveling algorithm to ensure that consecutive writes of a specific sector are not written physically to the same page/block in the flash. This spreads flash media usage evenly across all pages, thereby extending flash lifetime.

3.5 Bad Blocks Management

Bad Blocks are blocks that contain one or more invalid bits whose reliability are not guaranteed. The Bad Blocks may be presented while the SSD is shipped, or may develop during the life time of the SSD. When the Bad Blocks is detected, it will be flagged, and not be used anymore. The SSD implement Bad Blocks management, Bad Blocks replacement, Error Correct Code to avoid data error occurred. The functions will be enabled automatically to transfer data from Bad Blocks to spare blocks, and correct error bit.

3.6 iData Guard

Innodisk's power cycling management is a comprehensive data protection mechanism that functions before and after a sudden power outage to SSD. Low-power detection terminates data writing before an abnormal power-off, while table-remapping after power-on deletes corrupt data and maintains data integrity. Innodisk's power cycling provides effective power cycling management, preventing data stored in flash from degrading with use.

3.7 Garbage Collection

Garbage collection is used to maintain data consistency and perform continual data cleansing on SSDs. It runs as a background process, freeing up valuable controller resources while sorting good data into available blocks, and deleting bad blocks. It also significantly reduces write operations to the drive, thereby increasing the SSD's speed and lifespan.

4. Installation Requirements

4.1 SATADOM-ML 3SE3 Pin Directions

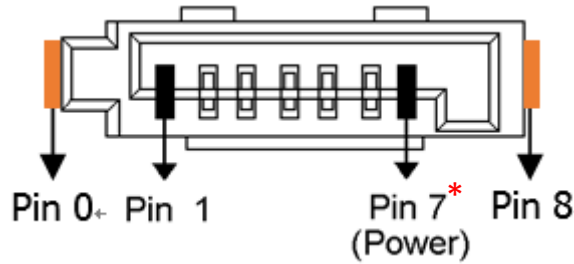

Figure 4: Signal Segment and Power Segment

*** SATADOM-ML 3SE3 default power supply through pin 8 or extra power cable.**

Pin 7 power supply as an optional function with separate PN end of B.

4.2 Electrical Connections for SATADOM-ML 3SE3

A Serial ATA device may be either directly connected to a host or connected to a host through a cable. For connection via cable, the cable should be no longer than 1 meter. The SATA interface has a separate connector for the power supply. Please refer to the pin description for further details.

4.3 Device Drive

No additional device drives are required. The Innodisk SATADOM-ML 3SE3 can be configured as a boot device.

4.4 Power supply for SATDOM

4.4.1 Power cable

A power cable is shipped with each SATADOM product, which has standard 4 pins power connector and special 3 pins power connector for SATADOM. The male and female power connector of SATADOM have foolproof design to avoid misconnection, please check it before power on. Innodisk also can customize the power connector for different host power socket design.

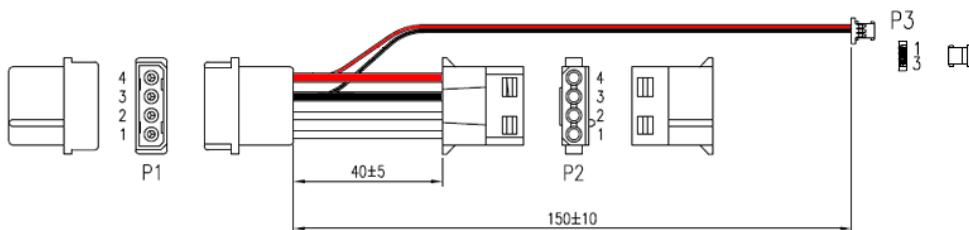

Figure 5: Standard power cable

4.4.2 Pin8 and Pin7 VCC

Innodisk’s SATADOM SSDs provide an elegant, compact option for SSD storage in embedded systems, industrial PCs and server motherboards with their small form factor that connects directly to the SATA connector on the motherboard. This simplified SSD design not only frees up a precious drive bay for other storage options but eliminates messy, obtrusive SATA data cabling. Innodisk’s patented Pin7 and Pin 8 SATA Power technologies take the cable-less concept to the next step by also eliminating the need for power cables for a 100% cable-less, shock resistant, space saving plug-and-play storage solution that optimizes airflow and makes the best use of limited board space in embedded and rackmount server systems.

SATADOM-ML 3SE3 series with Pin8/Pin7 VCC, it is defined Pin8/Pin7 as VCC on the SATA connector. Thus the power would come from SATA connector Pin8/Pin7 VCC. Customers DO NOT have to use the power cable for power supply. Such a cable-less design of SATADOM-ML 3SE3 series with Pin8/Pin7 VCC brings more convenience to customers’ system. The followings are the points customers have to be careful of while designing in SATADOM-ML 3SE3 series with Pin8/Pin7 VCC.

When customers use SATADOM with Pin8/Pin7 VCC and the host SATA socket does not have power on Pin8/Pin7, external power must be provided to the SATADOM from the 3pin connector on the side. To have the advantages of SATADOM-ML 3SE3 series with Pin8/Pin7 VCC, and to avoid any potential damage on customer’s board designed with VCC power supply. Innodisk suggests that customers MUST design their board with a fuse which should be designed before the SATA socket Pin8/Pin7 VCC. In other words, customers are suggested NOT TO layout 5V VCC to SATA socket on board directly. A circuit diagram example to explain this is shown as below.

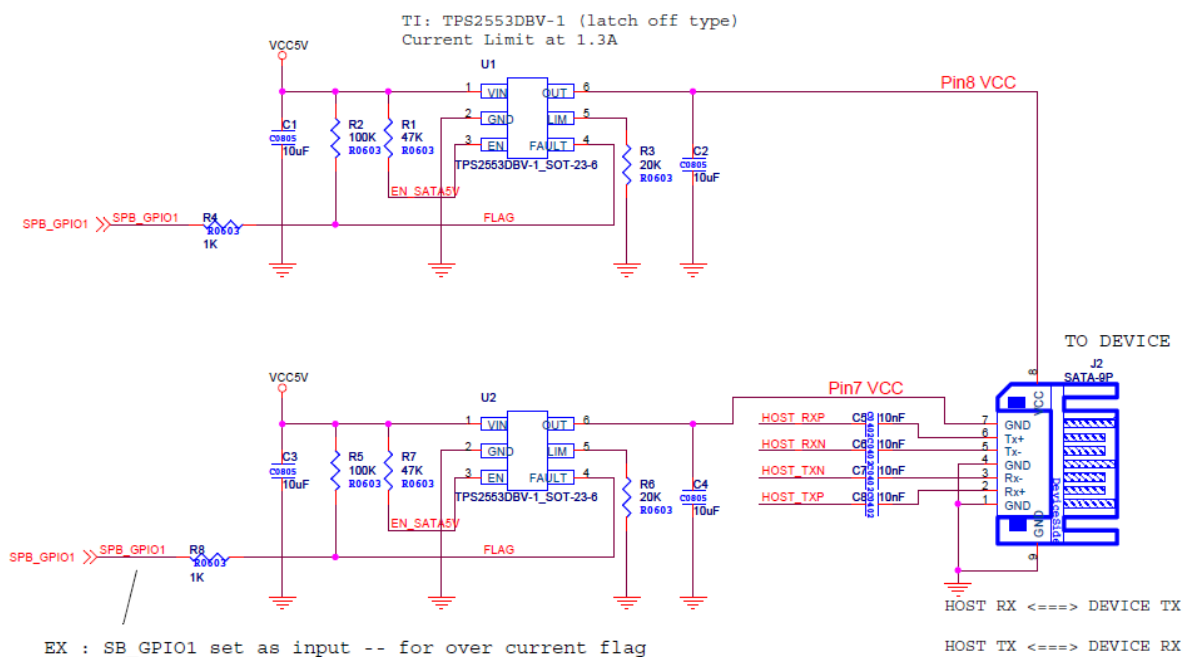

Figure 6: Pin 8 / Pin 7 host design in reference circuit

4.5 Write Protection

SATADOM-ML 3SE3 within the hardware write-protect function could prevent the device from modification and deletion. Write-protected data could only be read, that is, users could not write to it, edit it, append data to it, or delete it. When users would like to make sure that neither themselves nor others could modify or destroy the file, users could switch on write-protection. Thus, SATADOM-ML 3SE3 could process write-protect mechanism and disable flash memory to be written-in any data. Only while the system power-off, users could switch on write-protection. Write-protection could not be switched-on, after OS booting.

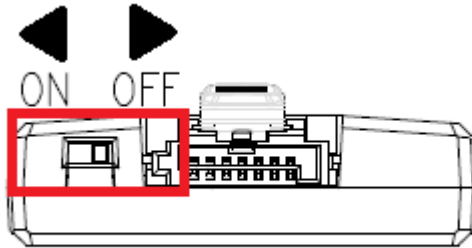

Figure 7: Hardware write protect position

5. Part Number Rule

CODE	1	2	3	4	5	6	7	8	9	10	11	12	13	14	15	16	17	18	19	20	21
	D	E	S	M	L	-	3	2	G	D	0	8	S	C	A	Q	B	A	X	X	X
Definition																					
Code 1st (Disk)											Code 14th (Operation Temperature)										
D : Disk											C: Standard Grade (0°C~ +70°C)										
Code 2nd (Feature set)											W: Industrial Grade (-40°C~ +85°C)										
E : Embedded series											Code 15th (Internal control)										
Code 3rd ~5th (Form factor)											A~Z: BGA PCB version										
SML: SATADOM-ML											Code 16th (Channel of data transfer)										
Code 7th ~9th (Capacity)											D: Dual Channels										
04G: 4GB			08G: 8GB			16G: 16GB					Q: Quad Channels										
32G: 32GB			64G: 64GB																		
Code 10th ~12th (Controller)																					
D08: 3SE3 Series											Code 17th (Flash Type)										
											B: Toshiba SLC										
Code 13th (Flash mode)											Code 18th (pin7 type)										
S: Synchronous flash											A: Pin8 version / Standard version										
											B: Pin8 & Pin7 version										
											Code 19th~21st (Customize code)										