

M.2 (S80)

3SE3 Series

Customer: _____
Customer
Part Number: _____
Innodisk
Part Number: _____
Innodisk
Model Name: _____
Date: _____

Innodisk Approver	Customer Approver

**Total Solution For
Industrial Flash Storage**

Table of contents

LIST OF FIGURES	6
1. PRODUCT OVERVIEW	7
1.1 INTRODUCTION OF INNODISK M.2 (S80) 3SE3	7
1.2 PRODUCT VIEW AND MODELS	7
1.3 SATA INTERFACE	7
2. PRODUCT SPECIFICATIONS	8
2.1 CAPACITY AND DEVICE PARAMETERS	8
2.2 PERFORMANCE	8
2.3 ELECTRICAL SPECIFICATIONS	8
2.3.1 Power Requirement	8
2.3.2 Power Consumption	9
2.4 ENVIRONMENTAL SPECIFICATIONS	9
2.4.1 Temperature Ranges	9
2.4.2 Humidity	9
2.4.3 Shock and Vibration	9
2.4.4 Mean Time between Failures (MTBF)	9
2.5 CE AND FCC COMPATIBILITY	10
2.6 RoHS COMPLIANCE	10
2.7 RELIABILITY	10
2.8 TRANSFER MODE	10
2.9 PIN ASSIGNMENT	11
2.11 ASSEMBLY WEIGHT	13
2.12 SEEK TIME	13
2.13 HOT PLUG	13
2.14 NAND FLASH MEMORY	13
3. THEORY OF OPERATION	14
3.1 OVERVIEW	14
3.2 SATA III CONTROLLER	14
3.3 ERROR DETECTION AND CORRECTION	15
3.4 WEAR-LEVELING	15
3.5 BAD BLOCKS MANAGEMENT	15
3.6 POWER CYCLING	15
3.7 GARBAGE COLLECTION	15
4. INSTALLATION REQUIREMENTS	16
4.1 M.2 (S80) 3SE3 PIN DIRECTIONS	16
4.2 ELECTRICAL CONNECTIONS FOR M.2 (S80) 3SE3	16

4.3 DEVICE DRIVE	16
5. PART NUMBER RULE	17

REVISION HISTORY

Revision	Description	Date
1.0	First Released	Nov., 2016
1.1	Update Reliability	Aug., 2024

List of Tables

TABLE 1: DEVICE PARAMETERS	8
TABLE 2: PERFORMANCE	8
TABLE 3: INNODISK M.2 (S80) 3SE3 POWER REQUIREMENT	8
TABLE 4: POWER CONSUMPTION	9
TABLE 5: TEMPERATURE RANGE FOR M.2 (S80) 3SE3	9
TABLE 6: SHOCK/VIBRATION TESTING FOR M.2 (S80) 3SE3	9
TABLE 7: M.2 (S80) 3SE3 MTBF	10
TABLE 8: INNODISK M.2 (S80) 3SE3 PIN ASSIGNMENT	11

List of Figures

FIGURE 1: INNODISK M.2 (S80) 3SE3 (TYPE 2280)	7
FIGURE 2: DIMENSION DIAGRAM	13
FIGURE 3: INNODISK M.2 (S80) 3SE3 BLOCK DIAGRAM	14
FIGURE 4: SIGNAL SEGMENT AND POWER SEGMENT	16

1. Product Overview

1.1 Introduction of Innodisk M.2 (S80) 3SE3

Innodisk M.2 (S80) 3SE3 is designed as the standard M.2 form factor with SATA interface, and supports SATA III standard (6.0Gb/s) with excellent performance. The form factor refers to the M.2(NGFF) specification which established by JEDEC. Regarding of mechanical interference, Innodisk M.2 (S80) 3SE3 absolutely replaces the traditional hard disk and makes personal computer, in any field, smaller and easier.

Innodisk M.2 (S80) 3SE3 effectively reduces the booting time of operation system and the power consumption is less than hard disk drive (HDD), and complies with ATA protocol, no additional drives are required, and can be configured as a boot device or data storage device

1.2 Product View and Models

Innodisk M.2 (S80) 3SE3 is available in follow capacities within SLC flash ICs.

[M.2 \(S80\) 3SE3 8GB](#)

[M.2 \(S80\) 3SE3 16GB](#)

[M.2 \(S80\) 3SE3 32GB](#)

[M.2 \(S80\) 3SE3 64GB](#)

[M.2 \(S80\) 3SE3 128GB](#)



Figure 1: Innodisk M.2 (S80) 3SE3 (type 2280)

1.3 SATA Interface

Innodisk M.2 (S80) 3SE3 supports SATA III interface, and compliant with SATA I and SATA II. SATA III interface can work with Serial Attached SCSI (SAS) host system, which is used in server computer. Innodisk M.2 (S80) 3SE3 is compliant with Serial ATA Gen 1, Gen 2 and Gen 3 specification (Gen 3 supports 1.5Gbps /3.0Gbps/6.0Gbps data rate).

2. Product Specifications

2.1 Capacity and Device Parameters

M.2 (S80) 3SE3 device parameters are shown in Table 1.

Table 1: Device parameters

Capacity	Cylinders	Heads	Sectors	LBA	user space
8GB	15525	16	63	15649200	7,641
16GB	16383	16	63	31277232	15,272
32GB	16383	16	63	62533296	30,533
64GB	16383	16	63	125045424	61,057
128GB	16383	16	63	250069680	122,104

2.2 Performance

Burst Transfer Rate: 6.0Gbps

Table 2: Performance

Capacity	8GB	16GB	32GB	64GB	128GB
Sequential* Read (max.)	320 MB/sec	370 MB/sec	370 MB/sec	380 MB/sec	380 MB/sec
Sequential* Write (max.)	100 MB/sec	170 MB/sec	200 MB/sec	220 MB/sec	220 MB/sec
4KB Random** Read (QD32)	12200 IOPS	12200 IOPS	12200 IOPS	12200 IOPS	12200 IOPS
4KB Random** Write (QD32)	11100 IOPS	18500 IOPS	20500 IOPS	20500 IOPS	20500 IOPS

Note: * Sequential performance is based on CrystalDiskMark 5.1.2 with file size 1000MB

** Random performance is based on IO meter with Queue Depth 32

2.3 Electrical Specifications

2.3.1 Power Requirement

Table 3: Innodisk M.2 (S80) 3SE3 Power Requirement

Item	Symbol	Rating	Unit
Input voltage	V _{IN}	+3.3 DC +- 5%	V

2.3.2 Power Consumption

Table 4: Power Consumption

Mode	Power Consumption (mA)
Read	562 (max.)
Write	594(max.)
Idle	126 (max.)

* Target: 128GB M.2 (S80) 3SE3

2.4 Environmental Specifications

2.4.1 Temperature Ranges

Table 5: Temperature range for M.2 (S80) 3SE3

Temperature	Range
Operating	Standard Grade: 0°C to +70°C
	Industrial Grade: -40°C to +85°C
Storage	-55°C to +95°C

2.4.2 Humidity

Relative Humidity: 10-95%, non-condensing

2.4.3 Shock and Vibration

Table 6: Shock/Vibration Testing for M.2 (S80) 3SE3

Reliability	Test Conditions	Reference Standards
Vibration	7 Hz to 2K Hz, 20G, 3 axes	IEC 60068-2-6
Mechanical Shock	Duration: 0.5ms, 1500 G, 3 axes	IEC 60068-2-27

2.4.4 Mean Time between Failures (MTBF)

Table 7 summarizes the MTBF prediction results for various M.2 (S80) 3SE3 configurations. The analysis was performed using a RAM Commander™ failure rate prediction.

- **Failure Rate:** The total number of failures within an item population, divided by the total number of life units expended by that population, during a particular measurement interval under stated condition.
- **Mean Time between Failures (MTBF):** A basic measure of reliability for repairable items: The mean number of life units during which all parts of the item perform within their specified limits, during a particular measurement interval under stated conditions.

Table 7: M.2 (S80) 3SE3 MTBF

Product	Condition	MTBF (Hours)
Innodisk M.2 (S80) 3SE3	Telcordia SR-332 GB, 25°C	>3,000,000

2.5 CE and FCC Compatibility

M.2 (S80) 3SE3 conforms to CE and FCC requirements.

2.6 RoHS Compliance

M.2 (S80) 3SE3 is fully compliant with RoHS directive.

2.7 Reliability

Parameter	Value
Read Cycles	Unlimited Read Cycles
Flash Endurance	60,000 P/E cycles
Wear-Leveling Algorithm	Support
Bad Blocks Management	Support
Error Correct Code	Support
Data Retention	Under 40°C: 1 Year at NAND Life End
TBW* (Total Bytes written)	
8GB	46.8
16GB	93.7
32GB	187.5
64GB	375
128GB	750
* Total bytes written is based on JEDEC 218 (Solid-State Drive Requirements and Endurance Test Method)	
** Lifespan is calculated by device written per day	

2.8 Transfer Mode

M.2 (S80) 3SE3 support following transfer mode:

Serial ATA III 6.0Gbps

Serial ATA II 3.0Gbps

Serial ATA I 1.5Gbps

2.9 Pin Assignment

Innodisk M.2 (S80) 3SE3 uses a standard SATA pin-out. See Table 8 for M.2 (S80) 3SE3 pin assignment.

Table 8: Innodisk M.2 (S80) 3SE3 Pin Assignment

Signal Name	Pin #	Pin #	Signal Name
		75	GND
3.3V	74	73	GND
3.3V	72	71	GND
3.3V	70	69	GND
SUSCLK	68	67	NC
Notch	66	65	Notch
Notch	64	63	Notch
Notch	62	61	Notch
Notch	60	59	Notch
Reserved/MFG Clock	58		
Reserved/ MFG Data	56	57	GND
NC	54	55	NC
NC	52	53	NC
NC	50	51	GND
NC	48	49	RX+
NC	46	47	RX-
NC	44	45	GND
NC	42	43	TX-
NC	40	41	TX+
DEVSLP	38	39	GND
NC	36	37	NC
NC	34	35	NC
NC	32	33	GND
NC	30	31	NC
NC	28	29	NC
NC	26	27	GND
NC	24	25	NC
NC	22	23	NC
NC	20	21	GND
Notch	18	19	Notch
Notch	16	17	Notch
Notch	14	15	Notch
Notch	12	13	Notch
DAS/DSS	10	11	NC

NC	8	9	NC
NC	6	7	NC
3.3V	4	5	NC
3.3V	2	3	GND
		1	GND

2.10 Mechanical Dimensions

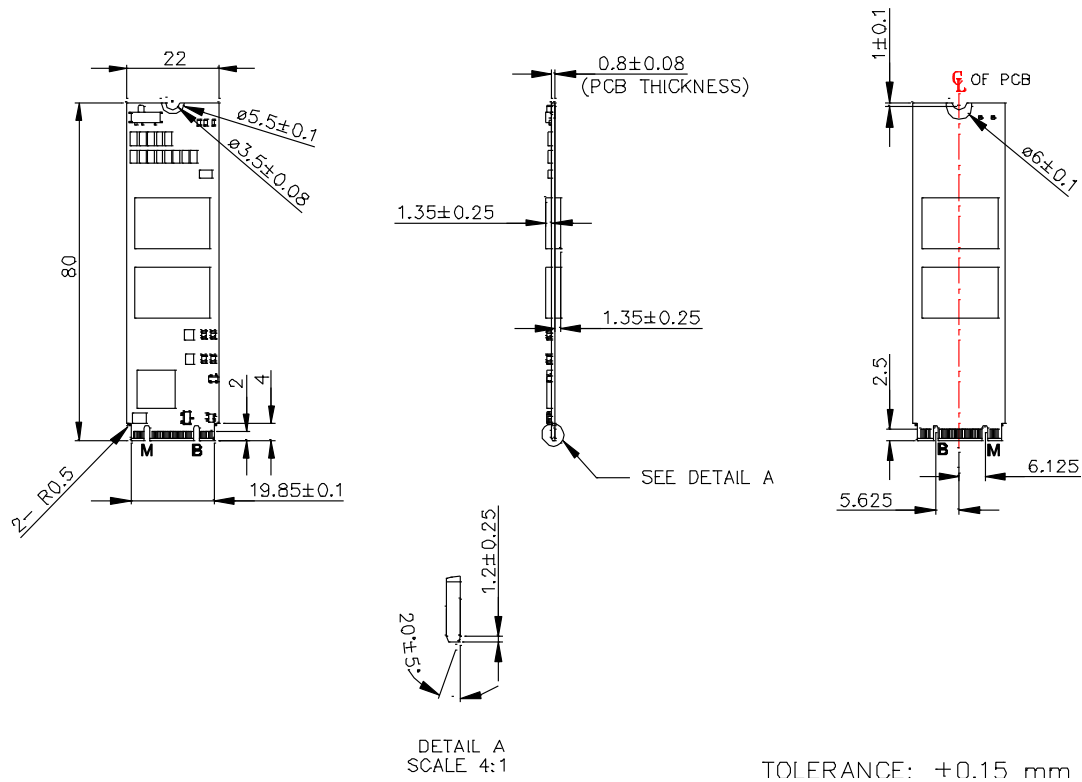

Figure 2: Dimension diagram

2.11 Assembly Weight

An Innodisk M.2 (S80) 3SE3 within flash ICs, 8GB's weight is 8 grams approximately.

2.12 Seek Time

Innodisk M.2 (S80) 3SE3 is not a magnetic rotating design. There is no seek or rotational latency required.

2.13 Hot Plug

The SSD support hot plug function and can be removed or plugged-in during operation. User has to avoid hot plugging the SSD which is configured as boot device and installed operation system.

Surprise hot plug : The insertion of a SATA device into a backplane (combine signal and power) that has power present. The device powers up and initiates an OOB sequence.

Surprise hot removal: The removal of a SATA device from a powered backplane, without first being placed in a quiescent state.

2.14 NAND Flash Memory

Innodisk M.2 (S80) 3SE3 uses Single Level Cell (SLC) NAND flash memory, which is non-volatility, high reliability and high speed memory storage. There are only two statuses 0 or 1 of one cell. Read or Write data to flash memory for SSD is control by microprocessor.

3. Theory of Operation

3.1 Overview

Figure 2 shows the operation of Innodisk M.2 (S80) 3SE3 from the system level, including the major hardware blocks.

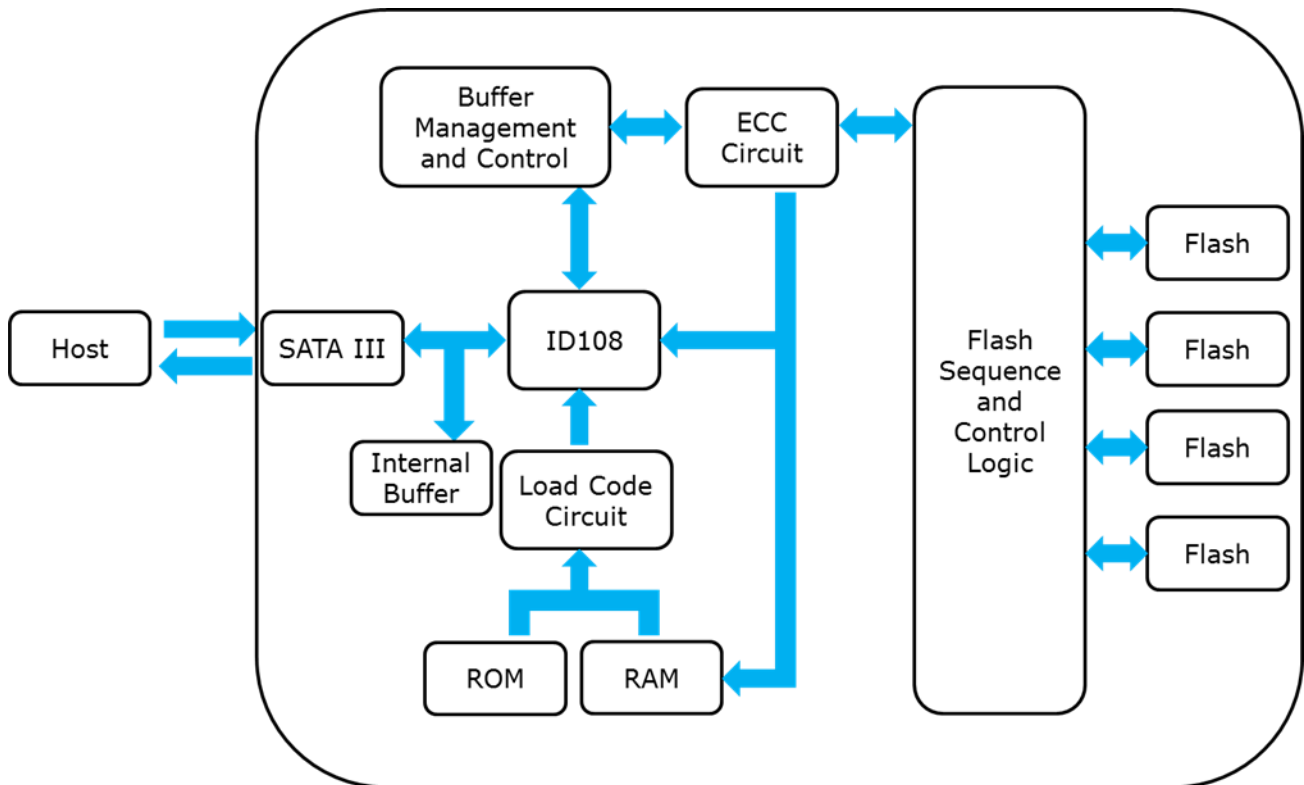

Figure 3: Innodisk M.2 (S80) 3SE3 Block Diagram

Innodisk M.2 (S80) 3SE3 integrates a SATA III controller and NAND flash memories. Communication with the host occurs through the host interface, using the standard ATA protocol. Communication with the flash device(s) occurs through the flash interface.

3.2 SATA III Controller

Innodisk M.2 (S80) 3SE3 is designed with ID 108, a SATA III 6.0Gbps (Gen. 3) controller. The Serial ATA physical, link and transport layers are compliant with Serial ATA Gen 1, Gen 2 and Gen 3 specification (Gen 3 supports 1.5Gbps/3.0Gbps/6.0Gbps data rate). The controller has 2 channels for flash interface.

3.3 Error Detection and Correction

Highly sophisticated Error Correction Code algorithms are implemented. The ECC unit consists of the Parity Unit (parity-byte generation) and the Syndrome Unit (syndrome-byte computation). This unit implements an algorithm that can correct 40 bits per 1024 bytes in an ECC block. Code-byte generation during write operations, as well as error detection during read operation, is implemented on the fly without any speed penalties.

3.4 Wear-Leveling

Flash memory can be erased within a limited number of times. This number is called the **erase cycle limit** or **write endurance limit** and is defined by the flash array vendor. The erase cycle limit applies to each individual erase block in the flash device.

Innodisk M.2 (S80) 3SE3 uses a static wear-leveling algorithm to ensure that consecutive writes of a specific sector are not written physically to the same page/block in the flash. This spreads flash media usage evenly across all pages, thereby extending flash lifetime.

3.5 Bad Blocks Management

Bad Blocks are blocks that contain one or more invalid bits whose reliability are not guaranteed. The Bad Blocks may be presented while the SSD is shipped, or may develop during the life time of the SSD. When the Bad Blocks is detected, it will be flagged, and not be used anymore. The SSD implement Bad Blocks management, Bad Blocks replacement, Error Correct Code to avoid data error occurred. The functions will be enabled automatically to transfer data from Bad Blocks to spare blocks, and correct error bit.

3.6 Power Cycling

Innodisk's power cycling management is a comprehensive data protection mechanism that functions before and after a sudden power outage to SSD. Low-power detection terminates data writing before an abnormal power-off, while table-remapping after power-on deletes corrupt data and maintains data integrity. Innodisk's power cycling provides effective power cycling management, preventing data stored in flash from degrading with use.

3.7 Garbage Collection

Garbage collection is used to maintain data consistency and perform continual data cleansing on SSDs. It runs as a background process, freeing up valuable controller resources while sorting good data into available blocks, and deleting bad blocks. It also significantly reduces write operations to the drive, thereby increasing the SSD's speed and lifespan.

4. Installation Requirements

4.1 M.2 (S80) 3SE3 Pin Directions

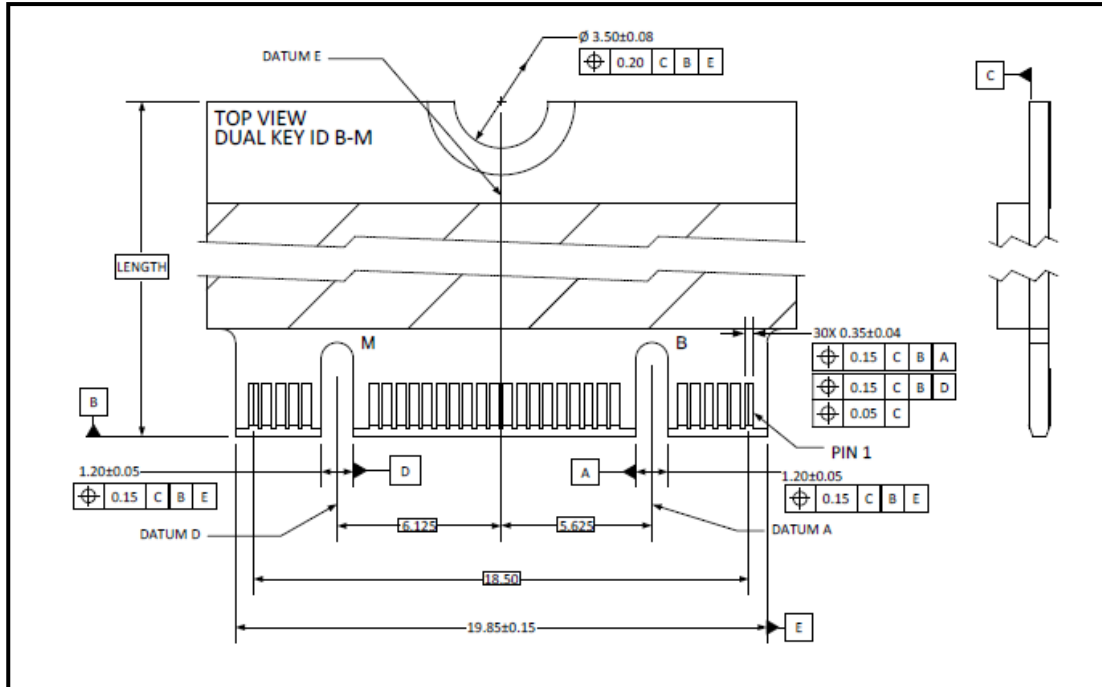

Figure 4: Signal Segment and Power Segment

4.2 Electrical Connections for M.2 (S80) 3SE3

A Serial ATA device may be either directly connected to a host or connected to a host through a cable. For connection via cable, the cable should be no longer than 1meter. The SATA interface has a separate connector for the power supply. Please refer to the pin description for further details.

4.3 Device Drive

No additional device drives are required. The Innodisk M.2 (S80) 3SE3 can be configured as a boot device.

5. Part Number Rule

CODE	1	2	3	4	5	6	7	8	9	10	11	12	13	14	15	16	17	18	19	20	21
	D	E	M	2	8	-	0	8	G	D	0	8	S	C	A	Q	B	-	X	X	X
Definition																					
Code 1st (Disk)											Code 13th (Flash mode)										
D: Disk											S: Synchronous NAND.										
Code 2nd (Feature set)											Code 14th (Operation Temperature)										
E: Embedded											C: Standard Grade (0°C ~ +70°C)										
											W: Industrial Grade (-40°C ~ +85°C)										
Code 3rd~5th (Form factor)																					
M28: M.2 Type 2280-D2-B-M											Code 15th (Internal control)										
											A: BGA PCB version.										
Code 7th~9th (Capacity)																					
08G: 8GB				64G: 64GB							Code 16th (Channel of data transfer)										
16G: 16GB				A28: 128GB							Q: Quad Channels										
32G: 32GB																					
											Code 17th (Flash Type)										
Code 10th ~12th (Controller)											B: Toshiba SLC										
D08:ID108											Code 19th~21st (Customize code)										