



L45

2U Liquid Cooler

PRODUCT SPECIFICATIONS

Specification Version: 03/04/2024

(Specifications are subject to change without notice)

Model Number: L45

- Recommend for Intel® CPU as following
 - Intel® Granite Rapid SP Processors, Socket LGA4710
- Liquid Cooler for 2U Server and Up

Overall Specification

- Coldplate Module with Copper Base
- Space saver light weight radiator
- 8cm Cooling Fans with 4-Pin PWM Connector
- Stand-alone Water Pump with Powerful Flow Rate 2.9 Liter Per Minute
- 30cm Black Pair EPDM Tube Assembled
- Mounting Accessories are included
- Shin-Etsu X23-8079-2 Thermal Compound Pre-Printed on Base
- Support CPU up to 600 Watts@40°C ambient Heat Dissipation
- **Each fan should have its own fan header due to high current consumption at full speed**

Cooling Fan Specification

Model Number	DF128038BX-PWMG
Dimension	80 x 80 x 38mm
Bearing	Dual Ball
Rated Voltage	12V
Rated Speed	At Duty Cycle 0~20%: 2400± 10% RPM At Duty Cycle 50%: 4800± 10% RPM At Duty Cycle 100%: 8000±10% RPM
Input Power	At Duty Cycle 0~20%: 1.2 W At Duty Cycle 50%: 5.52 W At Duty Cycle 100%: 24.72 W
Maximum Airflow	At Duty Cycle 0~20%: 35.52 CFM At Duty Cycle 50%: 67.24 CFM At Duty Cycle 100%: 115.61 CFM
Rated Static Pressure	At Duty Cycle 0~20%: 1.39 mm-H2O At Duty Cycle 50%: 5.97 mm-H2O At Duty Cycle 100%: 34.06 mm-H2O
Acoustical Noise	At Duty Cycle 0~20%: 25.63 dBA At Duty Cycle 50%: 47.85 dBA At Duty Cycle 100%: 64.40 dBA
Lead Wire Pin Out	Pin#1- Black(-) Pin#2- Yellow(+) Pin#3- Green(Tachometer/ Signal Output) Pin#4- Blue(PWM)

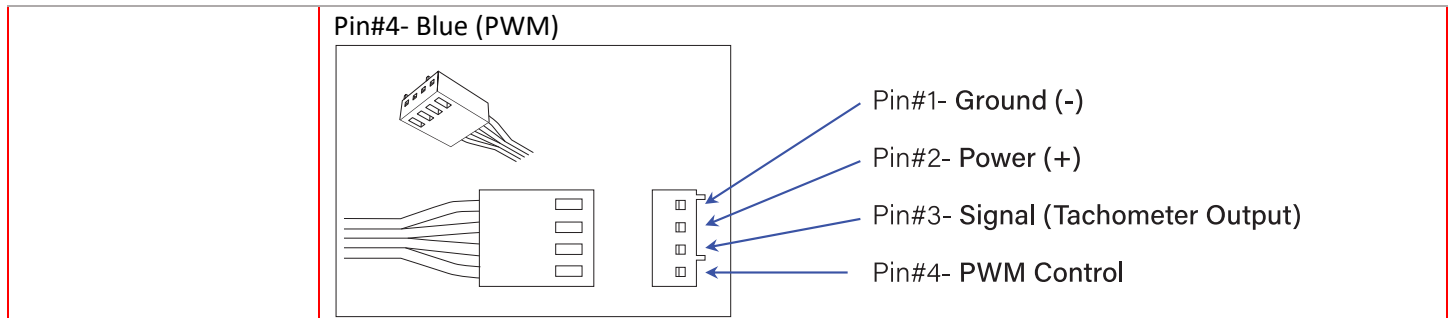

Performance Chart: Liquid Cooler L45 Thermal Resistance

Thermal Resistance vs. Fan Speed (Duty Cycle and RPM)

TBD

Publication History:

03/04/2024: Initial Release.

(Specifications are subject to change without notice)

4

3

2

1

REV#	DESCRIPTION	CHECKER	DATE
0.0	INITIAL RELEASE	JUN	03/01/24

F

F

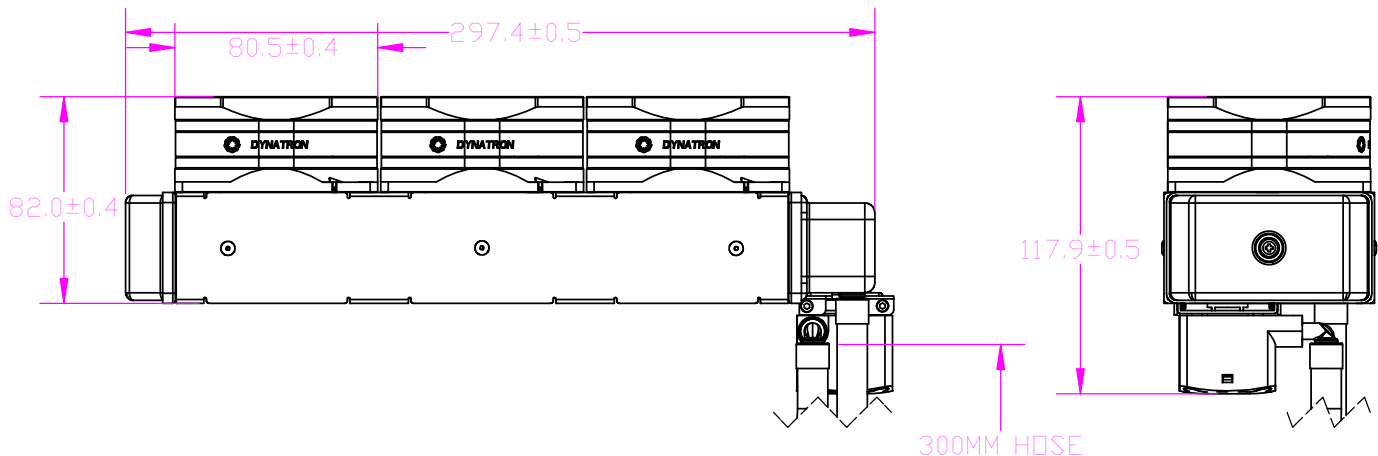

E

E

D

D

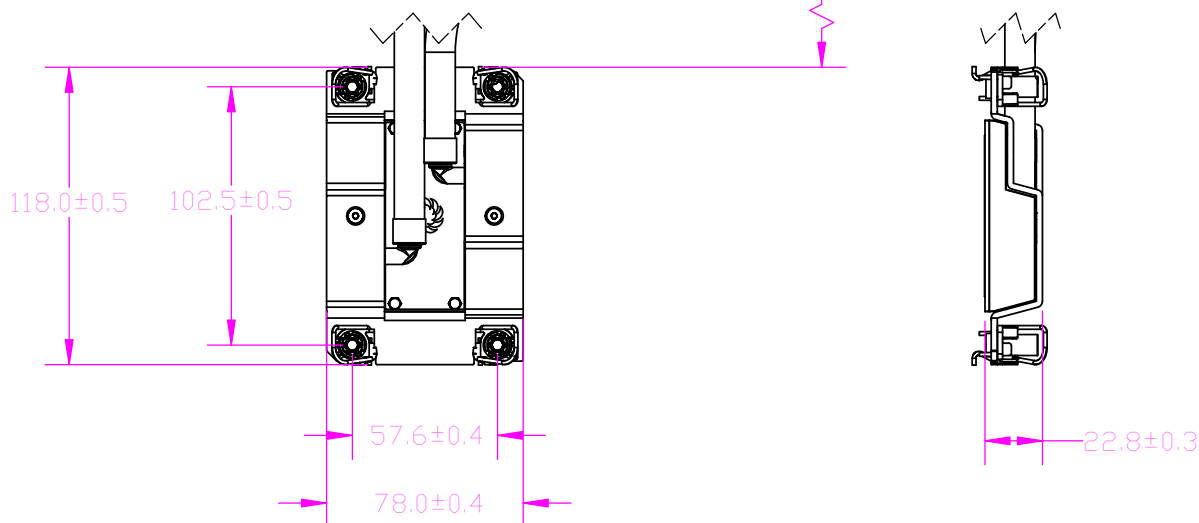

C

C

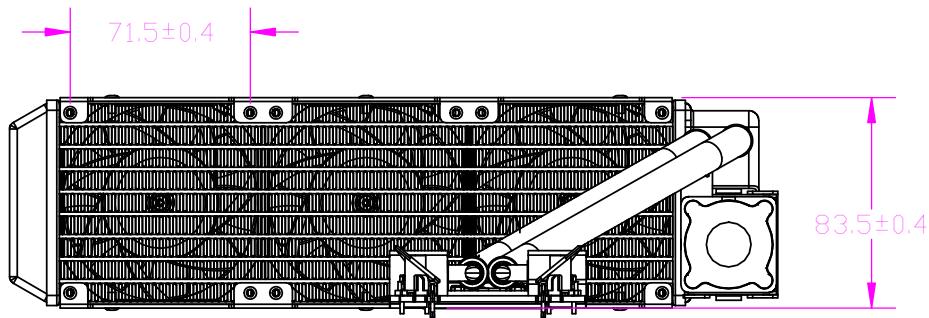

B

B

	NAME	DATE
DRAWN BY	JUN	3/4/2024
CHECKED BY	JUN	3/4/2024
ENG. APPROVED		
MFG. APPROVED		

 **DYNATRON CORPORATION**
 TOP MOTOR
 TITLE:
 2U LIQUID COOLER L45
 OVERALL DIMENSION DRAWING

A

A

CONFIDENTIAL DOCUMENT
 THIS DRAWING CONTAINS INFORMATION PROPRIETARY TO DYNATRON CORPORATION AND DYNAEON INDUSTRIAL CO., LTD. ANY REPRODUCTION, DISCLOSURE, OR USE OF THIS DRAWING IS EXPRESSLY PROHIBITED EXCEPT AS DYNATRON CORPORATION AND DYNAEON INDUSTRIAL CO., LTD. MAY OTHERWISE AGREE TO IN WRITING.

VIEW		DWG. No:	REV.
UNITS	MM	DYN-BD-L45	0.0

4

3

2

1

2

1

CONFIDENTIAL DOCUMENT

THIS DRAWING CONTAINS INFORMATION PROPRIETARY TO DYNATRON CORPORATION AND DYNAEON INDUSTRIAL CO., LTD. ANY REPRODUCTION, DISCLOSURE, OR USE OF THIS DRAWING IS EXPRESSLY PROHIBITED EXCEPT AS DYNATRON CORPORATION AND DYNAEON INDUSTRIAL CO., LTD. MAY OTHERWISE AGREE TO IN WRITING.

REV#	DESCRIPTION	CHECKER	DATE
0.0	INITIAL RELEASE	JUN	03/04/24

B

B

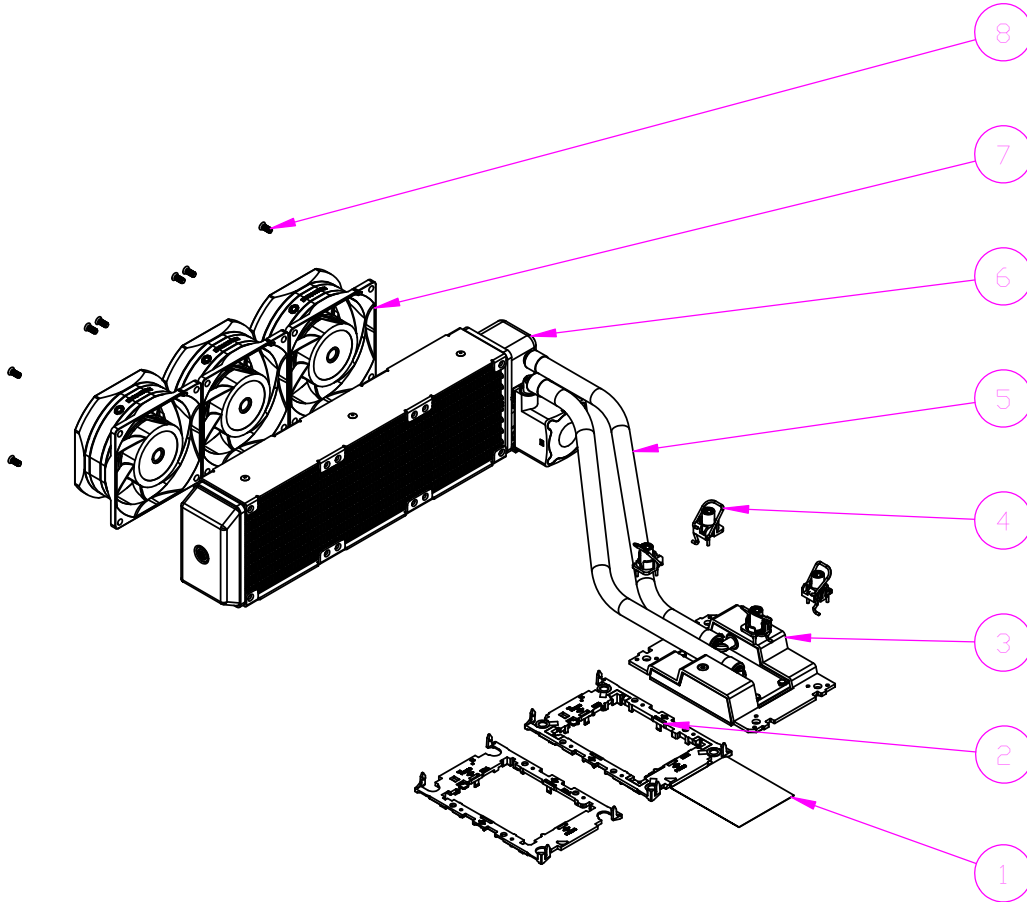
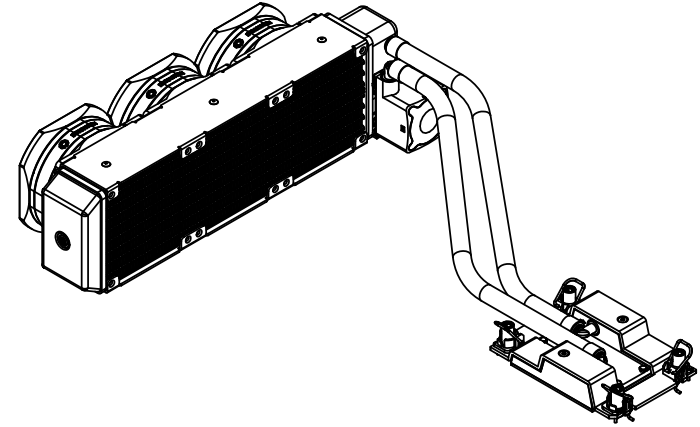

A

A

ITEM #	DESCRIPTION	MATERIAL	QTY.
8	SCREW, FAN	STEEL	12
7	FAN, DF128038BX-PWMG	PLASTIC	3
6	RADIATOR	ALUMINUM ALLOY	1
5	HOSE, 300MM	EPDM	2
4	ANTI-TILT RETENTION KIT	PLASTIC NUT, STEEL WIRE	4
3	WATER BLOCK	CU COLDPLATE, PLASTIC LTD	1
2	LGA4710 PACKAGE CARRIER (E2A + E2B)	PLASTIC	2
1	THERMAL GREASE	SHIN-ETSU X23-8079-2	N/A

	DATE	NAME	 DYNATRON CORPORATION <small>TOP MOTOR</small>
DRAWN	3/4/2024	JUN	
CHECKED	3/4/2024	JUN	
ENG.APPR.			
MFG.APPR.			TITLE: 2U LIQUID COOLER L45 BOM & exploded Assembly Drawing
COMMENTS:			DWG. NO. DNY-EP-L45
			REV 0.0

NOTES:
THE FIGURE IS FOR REFERENCE ONLY, AND NOT FOR SCALE

2

1