

AIMB-229

**AMD V2000-series Quad Core
Mini-ITX with 2 x HDMI,
2 x DP (Type-C), 8 x USB,
6 x COM, and 12V DC-in**

Copyright

The documentation and the software included with this product are copyrighted 2022 by Advantech Co., Ltd. All rights are reserved. Advantech Co., Ltd. reserves the right to make improvements in the products described in this manual at any time without notice. No part of this manual may be reproduced, copied, translated, or transmitted in any form or by any means without the prior written permission of Advantech Co., Ltd. The information provided in this manual is intended to be accurate and reliable. However, Advantech Co., Ltd. assumes no responsibility for its use, nor for any infringements of the rights of third parties that may result from its use.

Acknowledgments

AMI is a trademark of American Megatrends Inc.

IBM and PC are trademarks of International Business Machines Corporation.

AMD V-series is trademark of AMD Corporation.

Nuvoton is a trademark of Nuvoton Technology.

All other product names or trademarks are properties of their respective owners.

Product Warranty (2 years)

Advantech warrants the original purchaser that each of its products will be free from defects in materials and workmanship for two years from the date of purchase.

This warranty does not apply to any products that have been repaired or altered by persons other than repair personnel authorized by Advantech, or products that have been subject to misuse, abuse, accident, or improper installation. Advantech assumes no liability under the terms of this warranty as a consequence of such events.

Because of Advantech's high quality-control standards and rigorous testing, most customers never need to use our repair service. If an Advantech product is defective, it will be repaired or replaced free of charge during the warranty period. For out-of-warranty repairs, customers will be billed according to the cost of replacement materials, service time, and freight. Please consult your dealer for more details.

If you believe your product to be defective, follow the steps outlined below.

1. Collect all the information about the problem encountered. (For example, CPU speed, Advantech products used, other hardware and software used, etc.) Note anything abnormal and list any onscreen messages displayed when the problem occurs.
2. Call your dealer and describe the problem. Please have your manual, product, and any helpful information readily available.
3. If your product is diagnosed as defective, obtain a return merchandise authorization (RMA) number from your dealer. This allows us to process your return more quickly.
4. Carefully pack the defective product, a completed Repair and Replacement Order Card, and a proof of purchase date (such as a photocopy of your sales receipt) into a shippable container. Products returned without a proof of purchase date are not eligible for warranty service.
5. Write the RMA number clearly on the outside of the package and ship the package prepaid to your dealer.

Part No. 2006022900

Printed in China

Edition 1

July 2022

A Message to the Customer

Advantech Customer Services

Every Advantech product is built to the most exacting specifications to ensure reliable performance in the harsh and demanding conditions typical of industrial environments. Whether your new Advantech equipment is destined for the laboratory or factory floor, you can be assured that your product will provide the reliability and ease of operation for which the name Advantech has come to be known. Your satisfaction is our primary concern. Here is a guide to Advantech's customer services. To ensure you get the full benefit of our services, please follow the instructions carefully.

Technical Support

We want you to get the maximum performance from your products. So should you run into technical difficulties, we are here to help. For the most frequently asked questions, you can find answers in your product documentation. These answers are normally a lot more detailed than the ones we can provide over the phone. Therefore, please consult this manual first. If you still cannot find the answer, gather all the information or questions that apply to your problem, and with the product close at hand, call your dealer. Our dealers are well trained and ready to give the support you need to get the most from your Advantech products. In fact, most problems reported are minor and can be easily solved over the phone.

In addition, free technical support is available from Advantech engineers every business day. We are always ready to give advice regarding application requirements or specific information regarding the installation and operation of any of our products.

Declaration of Conformity

FCC Class B

This equipment has been tested and found to comply with the limits for a Class B digital device, pursuant to part 15 of the FCC Rules. These limits are designed to provide reasonable protection against harmful interference in a residential installation. This equipment generates, uses, and can radiate radio frequency energy and, if not installed and used in accordance with the instruction manual, may cause harmful interference to radio communications. However, there is no guarantee that interference will not occur in a particular installation. If this equipment does cause harmful interference to radio or television reception, which can be determined by turning the equipment off and on, the user is encouraged to try to correct the interference by one or more of the following measures:

- Reorient or relocate the receiving antenna.
- Increase the separation between the equipment and receiver.
- Connect the equipment into an outlet on a circuit different from that to which the receiver is connected.
- Consult the dealer or an experienced radio/TV technician for assistance.

Caution! *New batteries are at risk of exploding if incorrectly installed. Do not attempt to recharge, force open, or heat the battery. Replace the battery only with the same or equivalent type as recommended by the manufacturer. Discard used batteries according to the manufacturer's instructions.*



Memory Compatibility

Normal RAM Test Data

Category	Speed	Capacity	Vendor	ADVANTECH P/N	ECC
DDR4	2666	4GB	Advantech	SQR-SD4N4G2K6SNEFB	N
DDR4	2400	4GB	Advantech	SQR-SD4N4G2K4SNEFB	N
DDR4	2666	8GB	Advantech	SQR-SD4N8G2K6SNBCB	N
DDR4	2133	8GB	Advantech	AQD-SD4U8GN21-SG	N
DDR4	3200	8GB	Advantech	AQD-SD4U8GN32-SE	N
DDR4	3200	16GB	Advantech	SQR-SD4N16G3K2SNCB	N
DDR4	2666	16GB	Advantech	AQD-SD4U16N26-SE	N
DDR4	3200	32GB	Advantech	AQD-SD4U32GN32-SB	N
DDR4	2666	32GB	Advantech	SQR-SD4N32G2K6SNME	N

ECC RAM Test Data

Category	Speed	Capacity	Chip Vendor	ADVANTECH P/N	ECC
DDR4	2133	16GB	Advantech	AQD-SD4U16E21-SE	ECC
DDR4	3200	8GB	Advantech	SQR-SD4N8G3K2SEBCB	ECC
DDR4	3200	32GB	Advantech	AQD-SD4U32GE32-SB	ECC
DDR4	2400	8GB	Advantech	AQD-SD4U8GE24-HE	ECC
DDR4	2666	4GB	Advantech	SQR-SD4N4G2K6SEEFB	ECC
DDR4	2666	32GB	Advantech	SQR-SD4N32G2K6SEME	ECC

Ordering Information

P/N	Chipset	HDMI	eDP	DP 1.2	GbE LAN	COM	SATAIII	USB3.2 Gen2	USB3.2 Gen1	USB2.0	M.2	PCIex8	TPM	AMP
AIMB-229VGG2-00A1E	V2748	2 x (HDMI 2.0)	(1)	2	2	6	2	4	2	2	2	1	1	1
AIMB-229VGG2-00A2	V2718	2 x (HDMI 1.4)	(1)	2	2	6	2	4	2	2	2	1	1	(1)
AIMB-229VGG2-00A3	V2516	2 x (HDMI 1.4)	(1)	(2)	2	6	2	2	2	2	2	1	1	(1)

Initial Inspection

Before installing the motherboard, ensure that the following items are included with the product:

- 1 x AIMB-229 AMD V2000-series Quad Core Mini-ITX motherboard
- 1 x SATA HDD cable
- 1 x SATA power cable
- 1 x Serial port cable (1-to-1)
- 1 x Serial port cable (1-to-2)
- 1 x M.2 POST
- 2 x M.2 Screws
- 1 x I/O port bracket
- 1 x AIMB-229 startup manual
- 1 x Warranty card

If any of the above items are missing or damaged, contact your distributor or sales representative immediately. We have carefully inspected the AIMB-229 mechanically and electrically before shipment. The product should be free of marks and scratches and in perfect working order upon receipt. While unpacking AIMB-229, check the product for signs of shipping damage (for example, damaged box, scratches, or dents). If there is damage or the product fails to meet the specifications, notify our service department or your local sales representative immediately. Additionally, please notify the carrier. Retain the shipping carton and packing material for inspection by the carrier. After inspection, we will make arrangements to repair or replace the unit.

Contents

Chapter 1 General Information1

1.1	Introduction	2
1.2	Features	2
1.3	Specifications	2
1.3.1	Processor	2
1.3.2	Expansion	2
1.3.3	Memory	2
1.3.4	Graphics Interface	2
1.3.5	Ethernet Interface	2
1.3.6	SATA Interface	3
1.3.7	Rear I/O	3
1.3.8	Internal Connector	3
1.3.9	Watchdog Timer	3
1.3.10	Power Requirement	3
1.3.11	Environment	3
1.3.12	Physical Characteristics	3
1.4	Jumpers and Connectors	4
	Table 1.1: Connector/Header List	4
	Table 1.2: Jumper Setting List	5
1.4.1	Voltage Selection for LVDS1/EDP1 Connector (JEDP1)	6
1.4.2	CMOS Clear (JCMOS1)	6
1.4.3	PWRBTN#/ RESET#/HDD LED/Serial Bus from HW Monitor IC/ Internal Buzzer/External Speaker Header (JFP1)	6
1.4.4	Watchdog Timer Output and OBS Beep (JWDT1+ JOBS1)	7
1.4.5	AT/ATX Mode Selection (PSON1)	7
1.4.6	Case Open Selection Pin Header (JCASEOP_SW1)	7
1.4.7	COM1_RI# Pin RI#/5V/12V Selection (JSETCOM1_V1)	8
1.4.8	COM4_RI# Pin RI#/5V/12V Selection (JSETCOM4_V1)	8
1.4.9	CCTalk Power Voltage 5V/12V Select (JCCT_VCON1)	9
1.5	Jumper and Connector Locations	9
	Figure 1.1 Jumper and Connector Locations (Top Side)	9
	Figure 1.2 Jumper and Connector Locations (Bottom Side)	10
	Table 1.3: Connector/Header List	10
1.6	Board Diagram	12
	Figure 1.3 AIMB-229 Board Diagram	12
1.7	Safety Precautions	12
1.8	Jumper Settings	13
1.8.1	How to Set Jumpers	13
1.8.2	CMOS Clear (JCMOS1)	13
1.8.3	AT/ATX Mode Selection (PSON1)	13
1.9	System Memory	14
1.10	Memory Installation	14

Chapter 2 Connecting Peripherals15

2.1	Introduction	16
2.2	USB Ports	16
2.3	DisplayPort1/2/3/4	17
2.4	Serial Ports (COM1 ~ COM6)	18
2.5	CPU Fan Connector (CPU_FAN1)	19
2.6	System Fan Connector (SYSFAN1/2)	19
2.7	Power Switch/HDD LED/SMBUS/Speaker Pin Header (JFP1), Power LED, and Keyboard Lock Pin Header (JFP2)	20
2.7.1	ATX Soft Power Switch (JFP1/PWR_SW)	20

2.7.2	Reset (JFP1/RESET).....	20
2.7.3	HDD LED (JFP1/HDDLED)	20
2.7.4	External Speaker (JFP1/SPEAKER)	20
2.8	DC Input Jack and 4-Pin ATX Connector (DCIN1)	21
2.9	SATA Signal and Power Connector (SATA1~SATA2/SATA_PWR1~2).....	21
2.10	HD Analog Audio Interface (AUDIO1, AUDIO2, FPAUD1)	22
2.11	PCI-E x8 Slot (PCIEX8_1)	23
2.12	Low-Voltage Differential Signaling Interface (EDP1)	23
2.13	LVDS Backlight Inverter Power Connector (INV1).....	24
2.14	NGFF M.2 B-Key and E-Key Connector (M2B1 & M2E1)	24
2.15	Audio Amplifier Output Connector (AMP1), BOM Optional.....	25
2.16	General Purpose I/O Pin Header (GPIO1).....	25
2.17	General Purpose I/O Pin Header (BIOS1)	26
2.18	SPI Programming Pin Header (BIOS1_CN1)	26
2.19	Low-Pin-Count Header (LPC1)	27
2.20	Case-Open Detect Connector (JCASE2).....	27
2.21	CMOS Battery Connector (BAT1).....	28
2.22	DDR4 SODIMM Socket (DIMMA1, DIMMB1)	28
Chapter 3	BIOS Operation	29
3.1	Introduction	30
3.2	BIOS Setup	30
3.2.1	Main Menu	31
3.2.2	Advanced BIOS Features	32
3.3	Chipset Configuration Settings	53
3.3.1	South Bridge Configuration.....	54
3.3.2	GFX Configuration	56
3.3.3	North Bridge Configuration	57
3.3.4	Platform Misc Configuration.....	57
3.4	Security Settings	58
3.5	Boot Setting	59
3.6	Save & Exit Configuration	60
Chapter 4	Software and Services.....	63
4.1	Introduction	64
4.2	Value-Added Software Services	64
4.2.1	Software API.....	64
4.2.2	Software Utility.....	66
Chapter 5	Chipset Software Installation Utility	67
5.1	Before Beginning	68
5.2	Introduction	68
5.3	Windows 10 Driver Setup	68
Chapter 6	LAN Configuration	69
6.1	Introduction	70
6.2	Features.....	70
6.3	Installation.....	70
6.4	Windows 10 Driver Setup	70
Appendix A	I/O Pin Assignments	71

A.1	DC-IN Adaptor Connector (DCIN1).....	72
A.2	HDMI Port Connector (HDMI12).....	72
A.3	USB31X2_DP2	73
A.4	USB31X2_DP3	74
A.5	USB34.....	75
A.6	AT/ATX Mode Selection (PSON1).....	75
A.7	RJ45(LAN1+LAN2) Connector (LAN12).....	76
A.8	HD Analog Audio Interface Line-Out (AUDIO1).....	76
A.9	HD Analog Audio Interface MIC-In (AUDIO2).....	77
A.10	Audio Amplifier Output Pin Header (AMP1).....	77
A.11	Front Panel Audio Header (FPAUD1).....	78
A.12	CMOS Battery Wafer Box (BAT1).....	78
A.13	Serial ATA Interface Connector #2 (SATA2).....	78
A.14	HD Audio Interface (SPDIF1).....	79
A.15	M.2 -Key (NGFF_M1).....	79
A.16	EDP Differential Signaling (EDP1).....	80
A.17	PCI Express x8 Slot (PCIEX8_1).....	81
A.18	USB 2.0 Front-Panel Header (USB56).....	83
A.19	CPU Fan #1 Connector (CPUFAN1).....	83
A.20	M.2 E-Key Connector (M2E1).....	84
A.21	COM2 Box Header (COM2).....	85
A.22	COM1 RI# Selection Pin Header (JSETCOM1_V1).....	85
A.23	Inverter Power Connector (INV1).....	86
A.24	16-bit General Purpose I/O Pin Header (GPIO1).....	86
A.25	COM4 RI Selection Pin Header (JSETCOM4_V1).....	87
A.26	CCTALK Voltage Selection Pin Header (JCCT_VCON1).....	87
A.27	COM3 ~ COM4 Box Header (COM34).....	88
A.28	COM5 ~ COM6 Box Header (COM56).....	88
A.29	COM1 Box Header (COM1).....	89
A.30	Low-Pin-Count Interface Connector (LPC1).....	89
A.31	Serial ATA Power Connector #1 (SATA_PWR1).....	90
A.32	Serial ATA Power Connector #2 (SATA_PWR2).....	90
A.33	DDR4 SODIMM Socket CH-A (DIMMA1).....	90
A.34	DDR4 SODIMM Socket CH-B (DIMMB1).....	90
A.35	Power LED & Keyboard Lock Pin Header (JFP2).....	91
A.36	Watchdog Timer Output and OBS Beep (JWDT1+JOBS1).....	91
A.37	Case Open Connector (JCASE2).....	91
A.38	PWRBTN#/RESET#/HDD LED/Serial Bus From HW Monitor IC/Internal Buzzer/External Speaker Header (JFP1).....	92
A.39	System Fan #2 Connector (SYSFAN2).....	92
A.40	System Fan #1 Connector (SYSFAN1).....	92
A.41	SPI Pin Header (BIOS1_CN1).....	93
A.42	SPI BIOS Flash Socket (BIOS1).....	93
A.43	VDD Select for LVDS1 Panel (JEDP1).....	93
A.44	COMS Mode Selection (JCMOS1).....	94
A.45	VDD Select for LVDS1 Panel (JEDP1).....	94
A.46	CMOS Clear (JCMOS1).....	95
A.47	COM1_RI# Pin Selection (JSETCOM1_V1).....	95
A.48	COM4_RI# Pin Selection (JSETCOM4_V1).....	96
A.49	CCTALK Selection Pin Header (JCCT_VCON1).....	96
A.50	AT/ATX Mode Selection (PSON1).....	97
A.51	PWRBTN#/RESET#/HDD LED/Serial Bus/Internal Buzzer/External Speaker Header (JFP1).....	97
A.52	Watchdog Timer Output and OBS Beep (JWDT1+JOBS1).....	97

Chapter 1

General Information

1.1 Introduction

AIMB-229 is a mini-ITX motherboard based on the AMD Ryzen™ embedded V2000 series processor. Designed with diverse I/O and 4 x display outputs, AIMB-229 is ideal for multi-display applications in digital surveillance, digital signage, electronic gaming machines, and thin client operations. Advantech's WISE-PaaS/DeviceOn supports remote management software and enhances management efficiency.

1.2 Features

- **Comprehensive I/O:** 2 x Display ports, 2 x HDMI, 6 x serial ports, 2 x USB 2.0, 6 x USB 3.2, 2 x SATA III, 2 x GbE LAN, and 16-bit GPIO
- **Form Factor:** Mini-ITX motherboard
- **Diverse Storage Devices:** SATA HDD, M.2 (2242/2280) SSD
- **Optimized Integrated Graphics:** AMD Radeon Graphics, up to 7 x cores, up to 1.6GHz, 4K60 8/10b HVEC/VP9, & 8b H.264 Decode

1.3 Specifications

1.3.1 Processor

- **CPU:** AMD V series, supports 8-core/6-core CPUs
- **Max. Speed:**
 - 8-core 4.15 GHz (V2748/2718)
 - 4-core 3.95 GHz (V2516)
- **L2 Cache:** Max. 4 MB
- **BIOS:** AMI 128 Mbit SPI

1.3.2 Expansion

- **M.2 M Key:** 1 x (2242/2280)
- **M.2 E Key:** 1 x (2230)
- **PCIe x8:** 1 x (PCIe Gen3 x8 signal)

1.3.3 Memory

- **Technology:** Dual-channel DDR4 3200 MHz
- **Max. Capacity:** 64 GB (32GB per SODIMM)
- **Socket:** 2 x 260-pin SODIMM

1.3.4 Graphics Interface

- **Controller:** AMD Radeon Graphics
- **eDP:** 1 x (optional), supports dual-channel 48-bit, up to 1920 x colay DP 1.2 port (optional)
- **DP 1.2:** 2 x, supports DP++, up to 4096 x 2160 @ 60Hzresolution
- **Multiple Display:** 4 x independent displays via DP/HDMI

1.3.5 Ethernet Interface

- **Interface:** 10/100/1000 Mbps
- **Controller:** GbE: Realtek RTL8111H
- **Connector:** 2 x RJ-45

1.3.6 SATA Interface

- **Max. Data Transfer Rate:** 600 MB/s
- **Channel:** 2 x

1.3.7 Rear I/O

- **DP:** 2 x
- **Ethernet:** 2 x
- **USB:** 4 x (2 x USB 2.0, 6 x USB 3.2)
- **Audio:** 2 x (1 x Line-Out, 1 x Mic-In)
- **DC Jack:** 1 x

1.3.8 Internal Connector

- **LVDS & Inverter:** 1 x (optional)
- **USB:** 2 x (USB 2.0)
- **Serial:** 6 x (5 x RS232, 1 x RS232/422/485; COM 2 supports RS232/422/485 auto-flow control; COM 4 supports 5v/12V via jumper selection; 1 x COM supports CClalk; 1 x COM supports TTL)
- **SATA:** 2 x
- **SATA Power Connector:** 2 x
- **GPIO:** 16 bit
- **M.2:** 2 x (1 x M-key 2280/2242, 1 x E-key 2230)

1.3.9 Watchdog Timer

- **Output:** System reset
- **Interval:** Programmable 1 ~ 255 sec/min

1.3.10 Power Requirement

- **Typical:**
 - Wide voltage range: 12 ~ 24 V_{DC} input via 1 x 2.5φ connector or 1 x internal 2 x 2-pin power (12 V only)
 - AT/ATX supported by jumper
 - Max. power consumption: 58.4 W (16 GB DDR4 RAM)

1.3.11 Environment

- **Temperature:**
 - 0 ~ 60 °C (32 ~ 140 °F), operating
 - -40 ~ 85 °C (-40 ~ 185 °F), non-operating

1.3.12 Physical Characteristics

- **Dimensions:** 170 x 170 mm (6.69 x 6.69 in)

1.4 Jumpers and Connectors

The AIMB-229 motherboard features a number of jumpers and connectors that enable the integration of external devices, such as hard disk drives and a keyboard, and configuration according to specific applications.

The function of each board jumper and connector is listed in the tables below. Later sections in this chapter provide instructions for setting jumpers. Chapter 2 provides instructions for connecting external devices to the motherboard.

Table 1.1: Connector/Header List		
	Description	Part Reference
1	DC-IN adapter connector	DCIN1
2	HDIM Port connector	HDMI12
3	USB 3.0 Type A and Type C	USB31X2_DP2+USB1
4	USB 3.0 Type A and Type C	USB31X2_DP3+USB2
5	USB 3.1 Type A	USB34
6	AT/ATX Mode selection	PSON1
7	RJ45(LAN1+LAN2) connector	LAN12
8	HD Analog Audio Interface	AUDIO1
9	HD Analog Audio Interface	AUDIO2
10	Audio amplifier output pin header	AMP1
11	Front panel audio pin header	FPAUD1
12	SPDIF interface pin header	SPDIF_OUT1
13	Serial ATA interface connector	SATA2
14	AMD Hardware Debug Tool	HDT1
15	SATADOM power pin header	JSATAPWR1
16	M.2 M Key connector	NGFF_M1
17	PCI-Express x8 slot	PCIEX8_1
18	M.2 E Key connector	M2E1
19	COM1 RI# selection pin header	JSETCOM1_V1
20	LPC bus interface header	LPC1
21	COM1 box header	COM1
22	EDP Backlight inverter power connector	INV1
23	System fan connector	SYSFAN1
24	16-bits General Purpose I/O pin header	GPIO1
25	Case open selection pin header	JCASEOP_SW1
26	Case open pin header	JCASE2
27	BIOS code debug port	LED_PORT80
28	COM4 RI# selection pin header	JSETCOM4_V1
29	CCTalk power voltage select	JCCT_VCON1
30	COM56 box header	COM56
31	COM34 box header	COM34
32	Power LED	JFP2
33	Power switch/HDD LED/SMBus/Speaker	JFP1
34	System fan connector	SYSFAN2
35	CPU fan connector	CPUFAN1
36	SATA power connector	SATA_PWR1
37	Watchdog timer output and OBS beep	JWDT1+JOBS1



Item No.	Description	Part Reference
38	SATA power connector	SATA_PWR2
39	ATX Power supply(5VSB) connector	ATX_5VSB1
40	DDR3L SO-DIMM socket	DIMMA1/DIMMB1
41	BIOS flash pin header	BIOS1_CN1
42	COM2 box header	COM2
43	SPI BIOS socket	BIOS1
44	Dual port USB 2.0 pin header	USB56
45	Serial ATA interface connector	SATA1
46	eDP panel voltage selection	JEDP1
47	eDP panel connector	EDP1
48	RTC reset pin header	JCMOS1
49	CMOS battery wafer box	BAT1
50	ATX 12V power supply connector	ATX12V1/ ATX12V2

Item No.	Description	Part Reference
1	Voltage selection for LVDS1/EDP1 connector	JEDP1
2	RTC/CMOS clear	JCMOS1
3	PWRBTN#/RESET#/HDD LED/serial bus from HW monitor IC/internal buzzer/external speaker header	JFP1
4	Watchdog timer output and OBS beep	JWDT1+JOBS1
5	AT/ATX mode selection	PSON1
6	Case open selection pin header	JCASEOP_SW1
7	COM1_RI# pin selection pin header	JSETCOM1_V1
8	COM4_RI# pin selection pin header	JSETCOM4_V1
9	CCTalk power voltage select	JCCT_VCON1

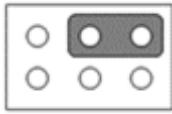
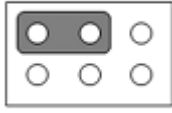
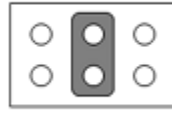
1.4.1 Voltage Selection for LVDS1/EDP1 Connector (JEDP1)

Function	Jumper Setting
Jumper position for +3.3V (default)	<p>2 4 6</p>  <p>1 3 5</p>
Jumper position for +5V	<p>2 4 6</p>  <p>1 3 5</p>
Jumper position for +12V	<p>2 4 6</p>  <p>1 3 5</p>

1.4.2 CMOS Clear (JCMOS1)

Function	Jumper Setting
Keep CMOS data (default)	<p>1 2 3</p> 
Clear CMOS data	<p>1 2 3</p> 

1.4.3 PWRBTN#/ RESET#/HDD LED/Serial Bus from HW Monitor IC/ Internal Buzzer/External Speaker Header (JFP1)

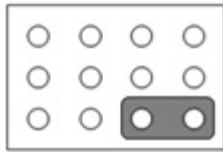
Function	Jumper Setting
Internal buzzer (default)	<p>3 12</p>  <p>1 7 10</p>

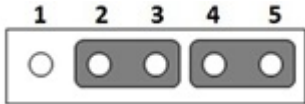

1.4.4 Watchdog Timer Output and OBS Beep (JWDT1+ JOBS1)

Function	Jumper Setting
Watchdog timer output (2-3) (default) OBS BEEP(4-5) (default)	

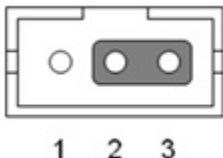
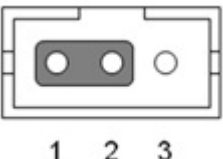

1.4.5 AT/ATX Mode Selection (PSON1)

Function	Jumper Setting
ATX mode (default)	
AT mode	



1.4.6 Case Open Selection Pin Header (JCASEOP_SW1)

Function	Jumper Setting
Normal close	
Normal open (default)	

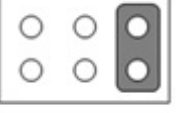

1.4.7 COM1_RI# Pin RI#/5V/12V Selection (JSETCOM1_V1)

Function	Jumper Setting
Jumper position for RI# (default)	<p>2 4 6</p>  <p>1 3 5</p>
Jumper position for +5V	<p>2 4 6</p>  <p>1 3 5</p>
Jumper position for +12V	<p>2 4 6</p>  <p>1 3 5</p>

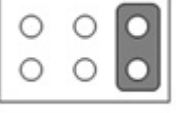
1.4.8 COM4_RI# Pin RI#/5V/12V Selection (JSETCOM4_V1)

Function	Jumper Setting
Jumper position for RI# (default)	<p>2 4 6</p>  <p>1 3 5</p>
Jumper position for +5V	<p>2 4 6</p>  <p>1 3 5</p>
Jumper position for +12V	<p>2 4 6</p>  <p>1 3 5</p>

1.4.9 CCTalk Power Voltage 5V/12V Select (JCCT_VCON1)

Function	Jumper Setting
Jumper position for +12V (default)	
Jumper position for +5V	

1.5 Jumper and Connector Locations

Top Layer Overview

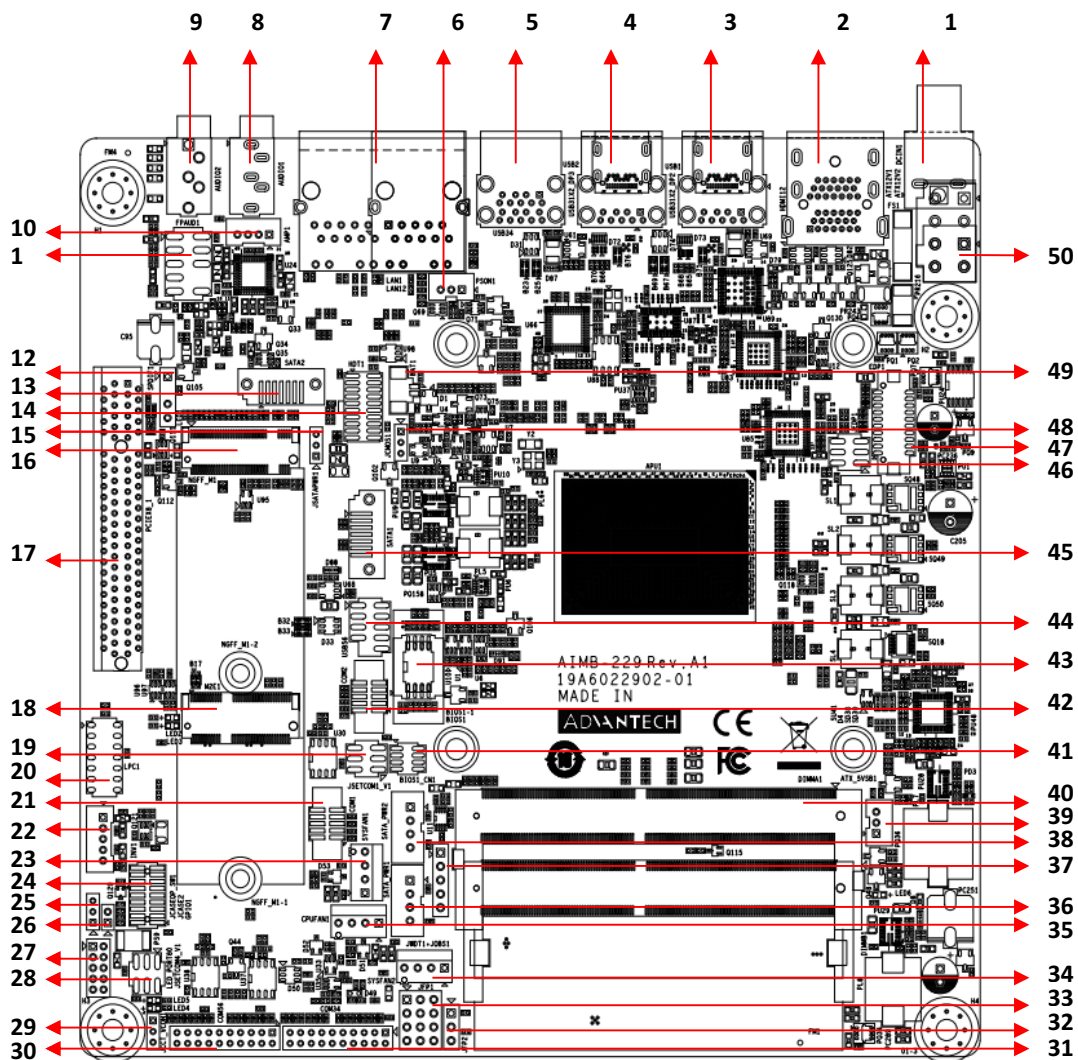

Figure 1.1 Jumper and Connector Locations (Top Side)

Bottom Layer Overview

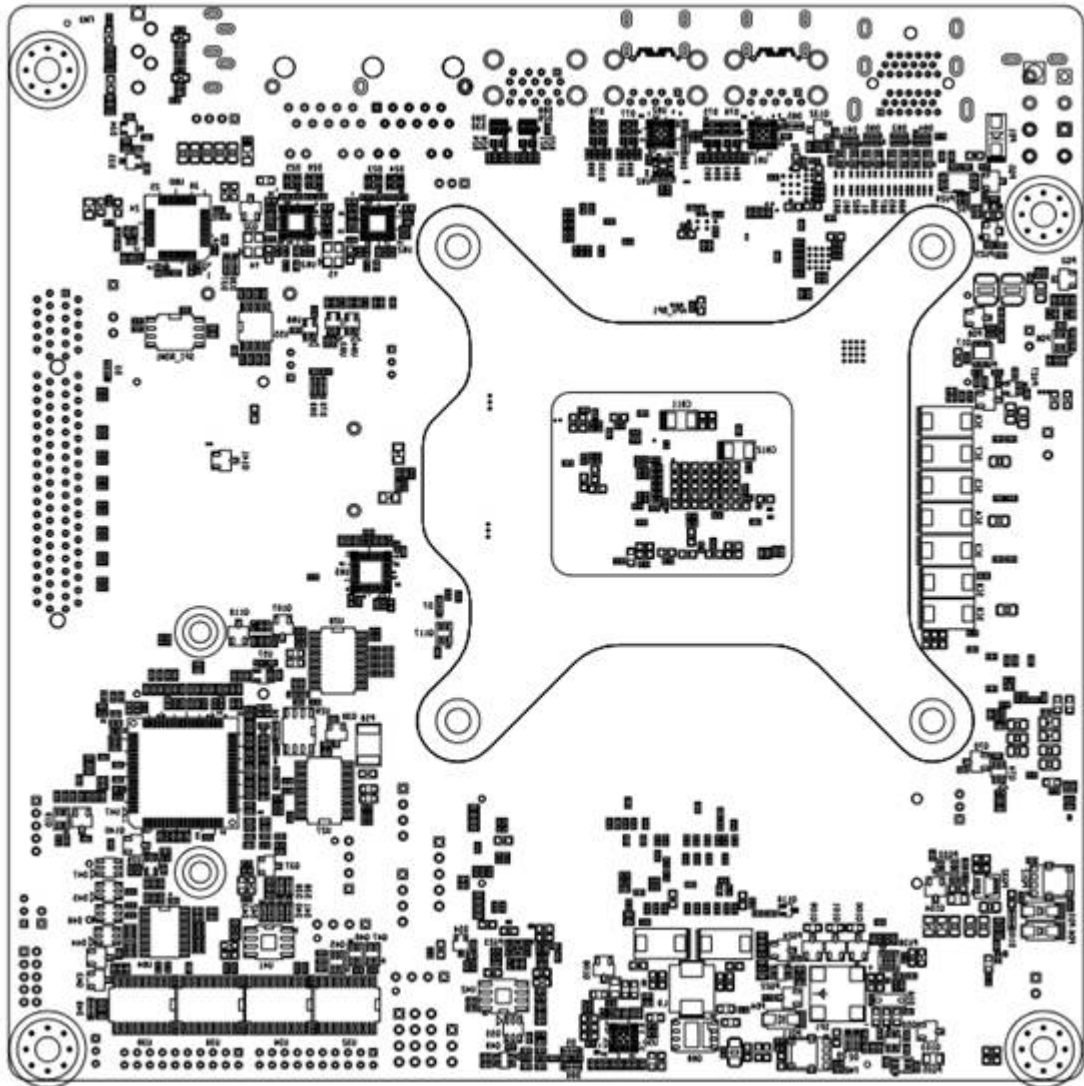

Figure 1.2 Jumper and Connector Locations (Bottom Side)

Table 1.3: Connector/Header List		
1	Description	Part Reference
1	DC-IN adaptor connector	DCIN1
2	HDIM Port connector	HDMI12
3	USB 3.0 Type A and Type C	USB31X2_DP2+USB1
4	USB 3.0 Type A and Type C	USB31X2_DP3+USB2
5	USB 3.1 Type A	USB34
6	AT/ATX Mode selection	PSO1
7	RJ45(LAN1+LAN2) connector	LAN12
8	HD Analog Audio Interface	AUDIO1
9	HD Analog Audio Interface	AUDIO2
10	Audio amplifier output pin header	AMP1
11	Front panel audio pin header	FPAUD1
12	SPDIF interface pin header	SPDIF_OUT1
13	Serial ATA interface connector	SATA2
14	AMD Hardware Debug Tool	HDT1
15	SATADOM power pin header	JSATAPWR1

Table 1.3: Connector/Header List		
16	M.2 M Key connector	NGFF_M1
17	PCI-Express x8 slot	PCIEX8_1
18	M.2 E Key connector	M2E1
19	COM1 RI# selection pin header	JSETCOM1_V1
20	LPC bus interface header	LPC1
21	COM1 box header	COM1
22	EDP Backlight inverter power connector	INV1
23	System fan connector	SYSFAN1
24	16-bits General Purpose I/O pin header	GPIO1
25	Case open selection pin header	JCASEOP_SW1
26	Case open pin header	JCASE2
27	BIOS code debug port	LED_PORT80
28	COM4 RI# selection pin header	JSETCOM4_V1
29	CCTalk power voltage select	JCCT_VCON1
30	COM56 box header	COM56
31	COM34 box header	COM34
32	Power LED	JFP2
33	Power switch/HDD LED/SMBus/Speaker	JFP1
34	System fan connector	SYSFAN2
35	CPU fan connector	CPUFAN1
36	SATA power connector	SATA_PWR1
37	Watchdog timer output and OBS beep	JWDT1+JOBS1
38	SATA power connector	SATA_PWR2
39	ATX Power supply(5VSB) connector	ATX_5VSB1
40	DDR3L SO-DIMM socket	DIMMA1, DIMMB1
41	BIOS flash pin header	BIOS1_CN1
42	COM2 box header	COM2
43	SPI BIOS socket	BIOS1
44	Dual port USB2.0 pin header	USB56
45	Serial ATA interface connector	SATA1
46	eDP panel voltage selection	JEDP1
47	eDP panel connector	EDP1
48	RTC reset pin header	JCMOS1
49	CMOS battery wafer box	BAT1
50	ATX 12V power supply connector	ATX12V1/ATX12V2

1.6 Board Diagram

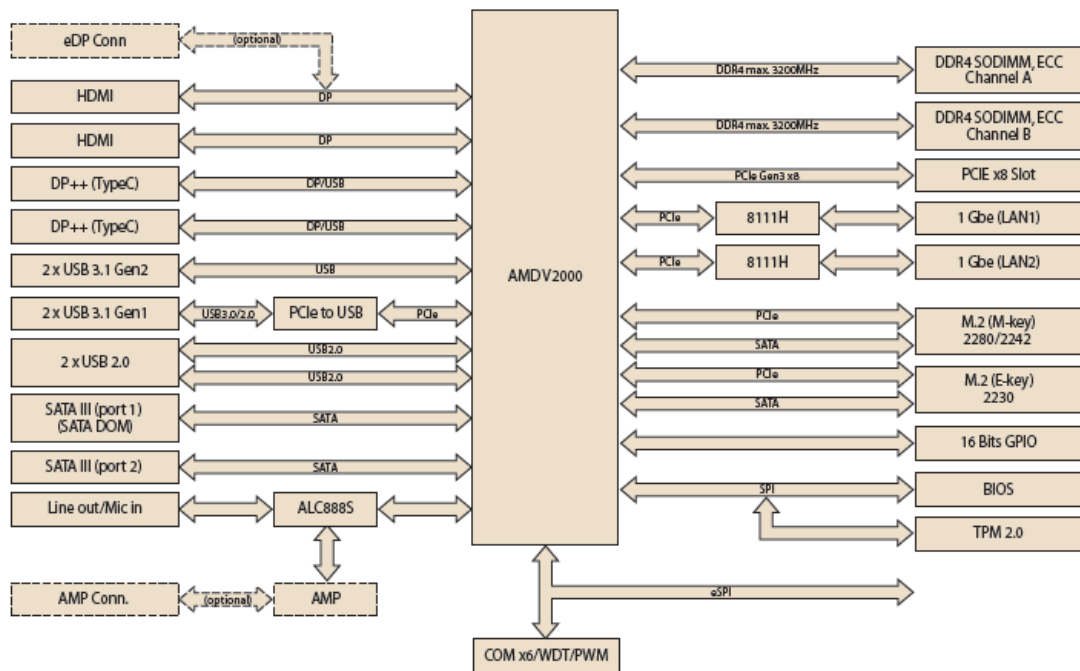

Figure 1.3 AIMB-229 Board Diagram

1.7 Safety Precautions

Warning! Always completely disconnect the power cord from the chassis before manual handling this device. Do not make connections while the power is on. Sensitive electronic components can be damaged by sudden power surges. Only experienced electronics personnel should open the PC chassis.



Caution! Always ground yourself to remove any static charge before touching the motherboard. Modern electronic devices are very sensitive to electrostatic discharges. As a safety precaution, use a grounding wrist strap at all times. Place all electronic components on a static-dissipative surface or in a static-shielded bag when not in the chassis.



Caution! The computer is provided with a battery-powered real-time clock circuit. There is a danger of explosion if the battery is incorrectly replaced. Replace only with the same or equivalent type as recommended by the manufacturer. Discard used batteries according to the manufacturer's instructions.



Caution! There is a danger of a new battery exploding if incorrectly installed. Do not attempt to recharge, force open, or heat the battery. Replace the battery only with the same or equivalent type recommended by the manufacturer. Discard used batteries according to the manufacturer's instructions.





1.8 Jumper Settings

This section provides instructions on how to configure the motherboard by setting jumpers. The information also includes the motherboards' default settings and the options for each jumper.

1.8.1 How to Set Jumpers

Users can configure the motherboard according to the specific application requirements by setting the jumpers. A jumper is a metal bridge that closes an electrical circuit. It consists of two metal pins and a small metal clip (often protected by a plastic cover) that slides over the pins to connect them. To “close” (or turn on) a jumper, connect the pins with the clip. To “open” (or turn off) a jumper, remove the clip. Sometimes a jumper consists of a set of three pins, labeled 1, 2, and 3. In this case, connect either pins 1 and 2, or 2 and 3. A pair of needle-nose pliers may be useful when setting jumpers.

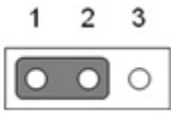
1.8.2 CMOS Clear (JCMOS1)

Function	Jumper Setting
Normal (default)	
Clear CMOS data	

1.8.3 AT/ATX Mode Selection (PSON1)

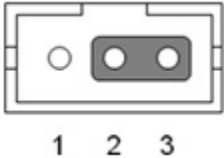
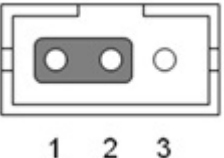
Function	Jumper Setting
ATX mode (default)	
AT mode	

1.9 System Memory

AIMB-229 is equipped with two sockets for 260-pin SODIMM. These sockets are compatible with 1.2V unbuffered double-data-rate synchronous, low-voltage DRAM (DDR4 SDRAM). DRAM is available in 4, 8, 16, and 32 GB capacities. The socket supports any combination of DIMMs of any size, for a total memory size of 4 to 32 GB. AIMB-229 supports ECC (error checking and correction) memory.

1.10 Memory Installation

To install SODIMMs, first ensure that the handles of the SODIMM socket are in the “open” position (i.e., the handles lean outward). Slowly slide the SODIMM module along the plastic guides on both ends of the socket. Then gently press the SODIMM module into the socket until there is an audible click indicating that the two handles have locked the memory module into place. To remove the memory module, push both handles outward, and the memory module will be ejected.

Chapter 2

Connecting
Peripherals

2.1 Introduction

Most of the connectors can be accessed from the top of the board during installation. If a number of cards are installed or the chassis is packed, the board may need to be partially removed in order to make all the connections.

2.2 USB Ports

(USB31X2_DP2+USB1/USB31X2_DP3+USB2/USB34/USB56)

AIMB-229 provides up to 8 x USB ports (6 x USB 3.1 and 6 x USB 2.0 on the rear side and 2 x USB 2.0 via the board pin header). The USB interface complies with USB Rev. 3.1 specifications and supports transmission rates of up to 10 Gbps. The USB interfaces can be disabled in the BIOS.

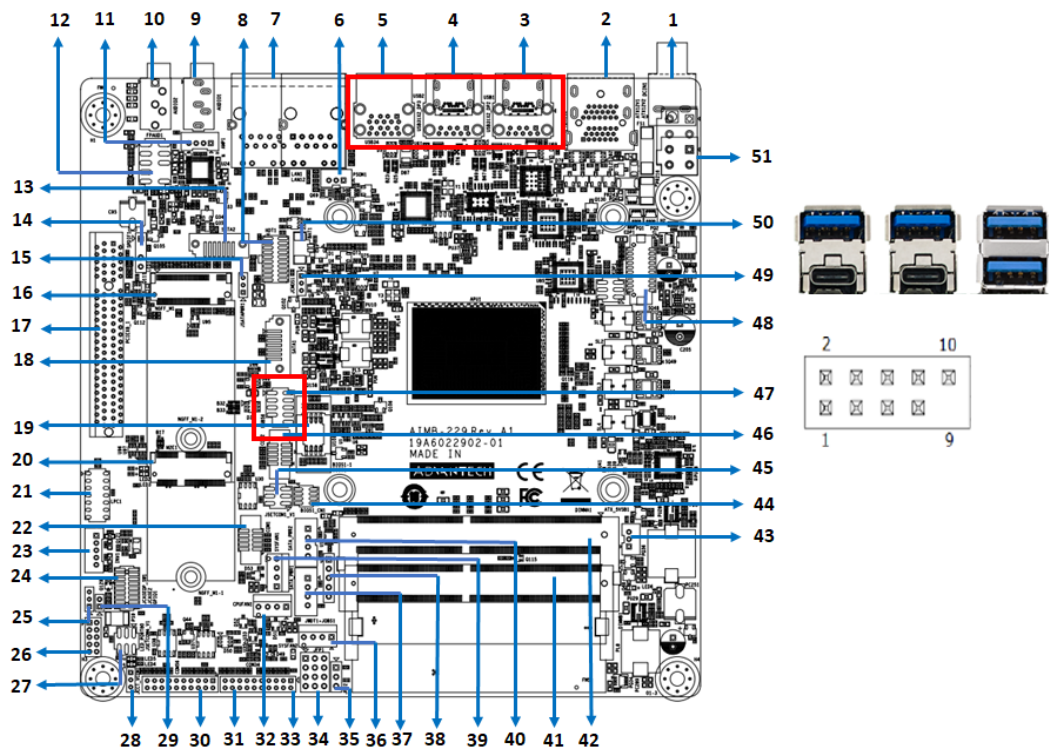

2.3 DisplayPort1/2/3/4

(HDMI12/ USB31X2_DP2+USB1/USB31X2_DP3+USB2)
 AIMB-229 features 4 x DP connectors.

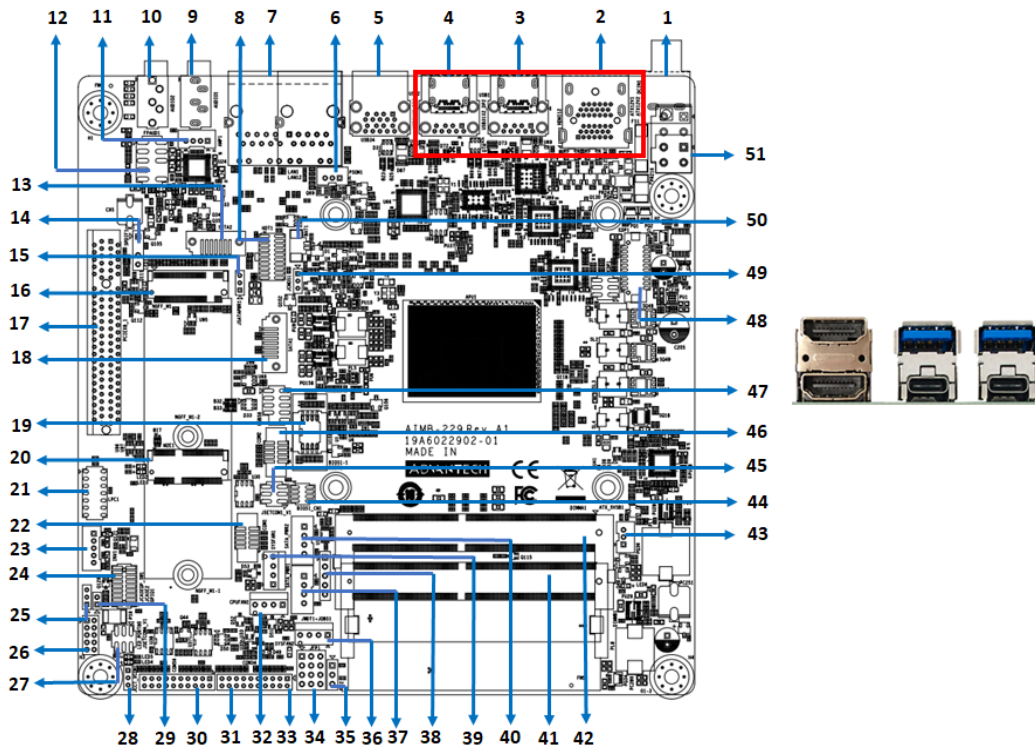

2.4 Serial Ports (COM1 ~ COM6)

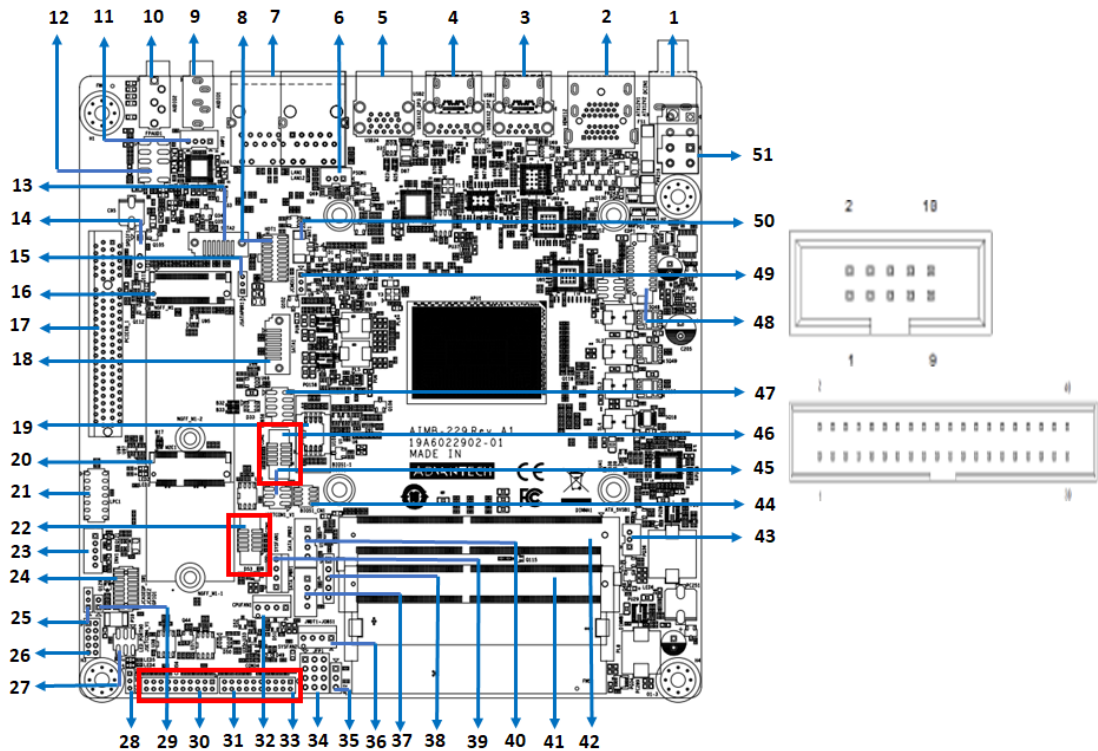

AIMB-229 supports six serial ports (COM1 and COM6 support RS-232 function, COM2 and COM5 support RS-232/422/485 function via jumper setting, COM3 colay CCTalk, and COM4 colay TTL).

These ports can be connected to serial devices, such as a mouse or printer, or a communications network. The IRQ and address ranges for both ports are fixed. However, users can disable the port or change the parameters via the BIOS. Different devices implement the RS-232 standards in different ways. If you have problems with a serial device, check the pin assignments of the connector.

2.5 CPU Fan Connector (CPU_FAN1)

This connector supports cooling fans of 500 mA (6 W) or less.

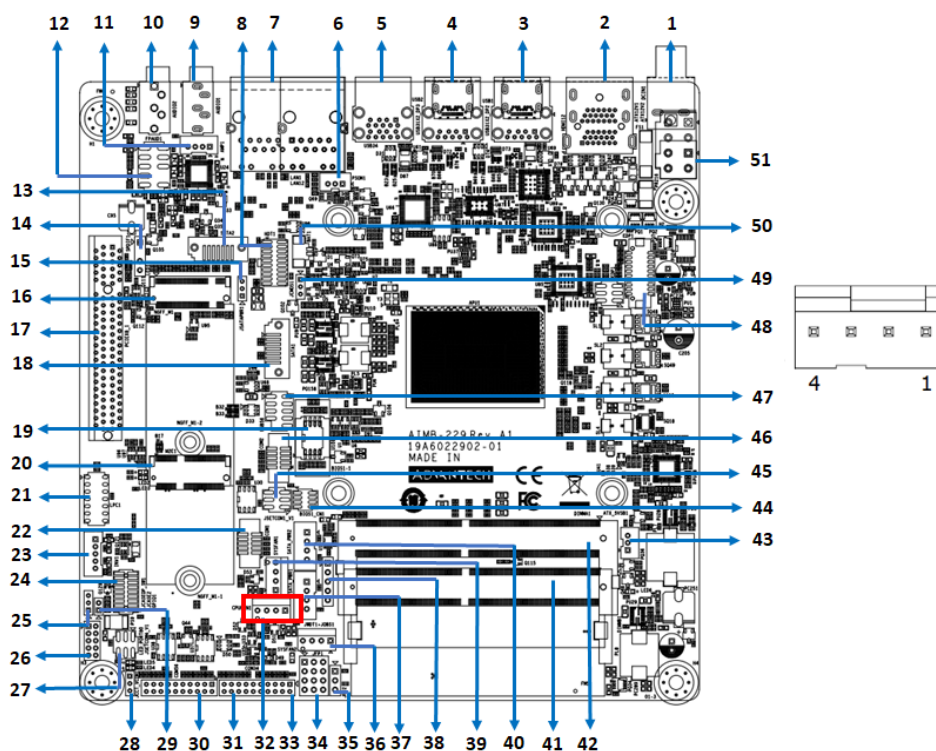

2.6 System Fan Connector (SYSFAN1/2)

This connector supports cooling fans of 500 mA (6 W) or less.

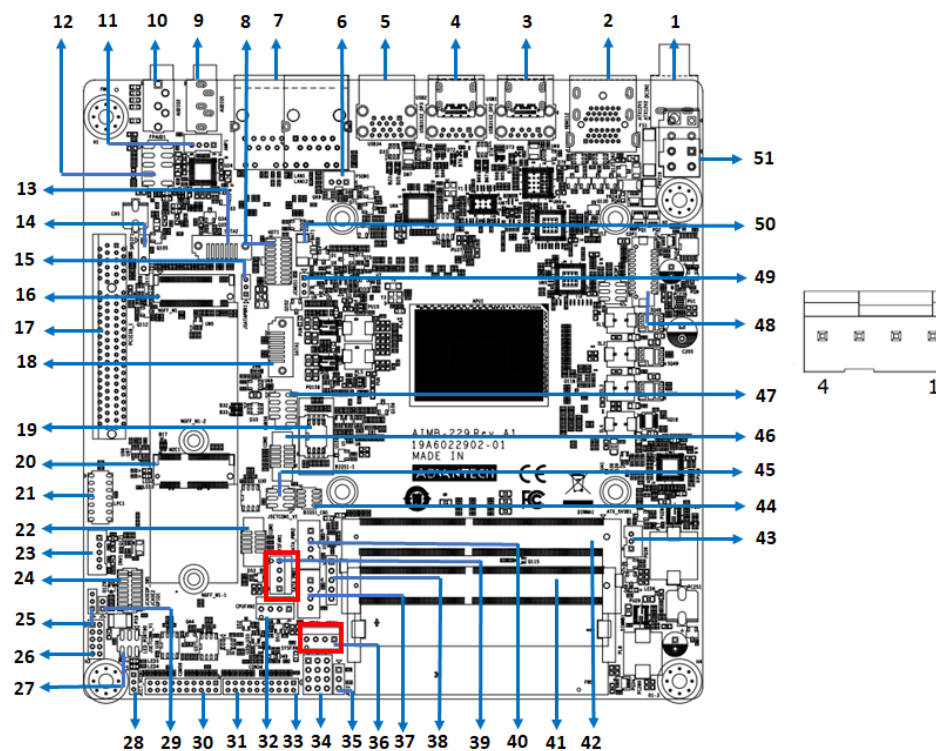

2.7 Power Switch/HDD LED/SMBUS/Speaker Pin Header (JFP1), Power LED, and Keyboard Lock Pin Header (JFP2)

There are several headers for monitoring and controlling the AIMB-229.

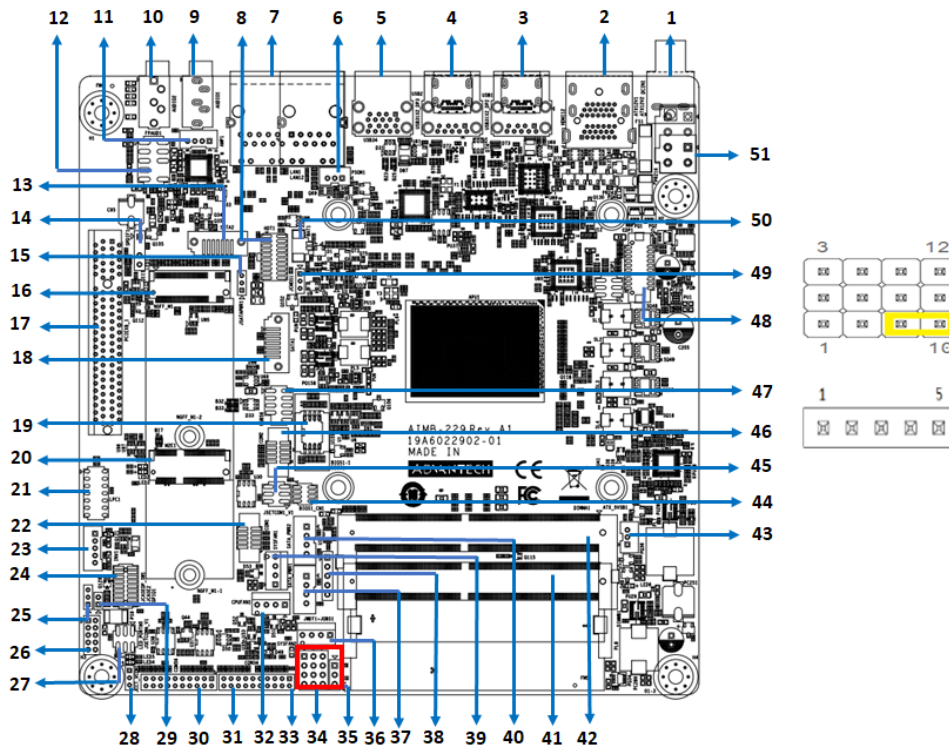

2.7.1 ATX Soft Power Switch (JFP1/PWR_SW)

If your computer case is equipped with an ATX power supply, connect the power on/off button on the computer case to JFP1/ PWR_SW for convenient operation.

2.7.2 Reset (JFP1/RESET)

Many computer cases offer the convenience of a reset button. Connect the wire for the reset button.

2.7.3 HDD LED (JFP1/HDDLED)

Connect an LED to JFP1/HDDLED to provide an indicator of when the HDD is active.

2.7.4 External Speaker (JFP1/SPEAKER)

JFP1/SPEAKER is a 4-pin connector for an external speaker. If there is no external speaker, AIMB-275 provides an onboard buzzer as an alternative. To enable the buzzer, set pins 7 and 10 as closed.

2.8 DC Input Jack and 4-Pin ATX Connector (DCIN1)

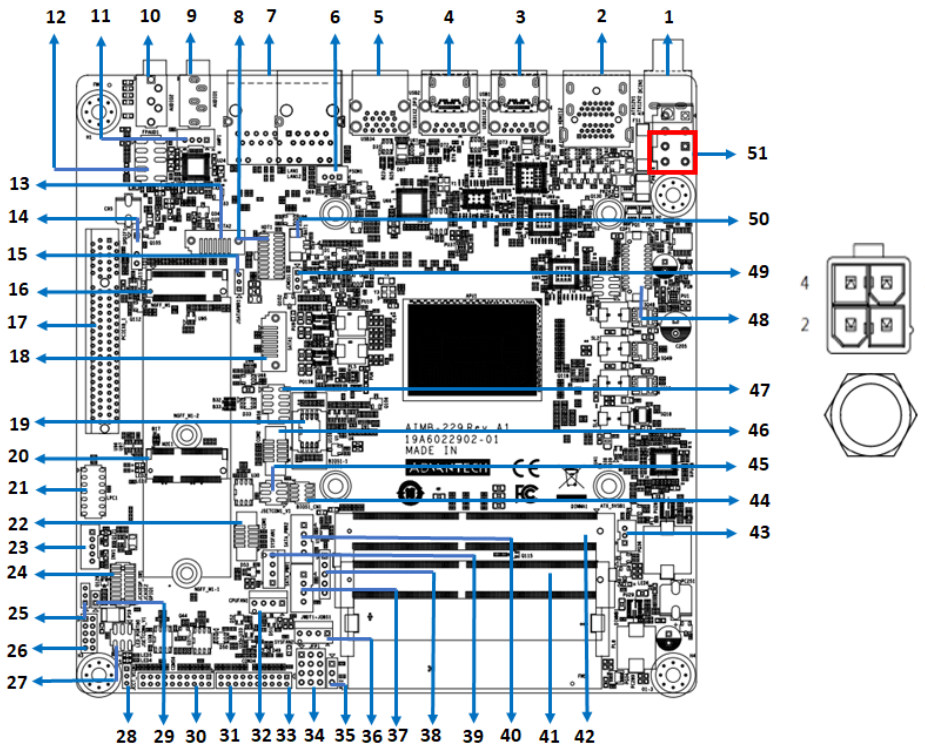

2.9 SATA Signal and Power Connector (SATA1~SATA2/SATA_PWR1~2)

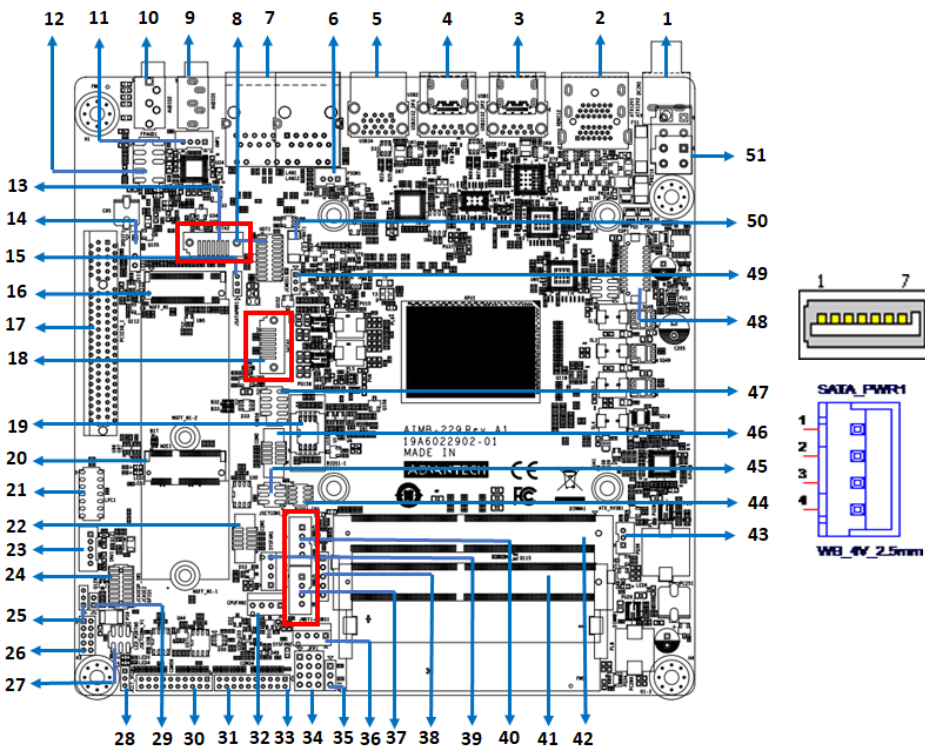

AIMB-229 features a high-performance serial ATA III interface (up to 600 MB/s) that supports thin space-saving cables to streamline hard drive cabling.

2.10 HD Analog Audio Interface (AUDIO1, AUDIO2, FPAUD1)

The FPAUD1 connector is for a chassis-mounted front-panel audio I/O module that supports either HD Audio or legacy AC'97 (optional) standard.

Connect this connector with the front-panel audio I/O module cable.

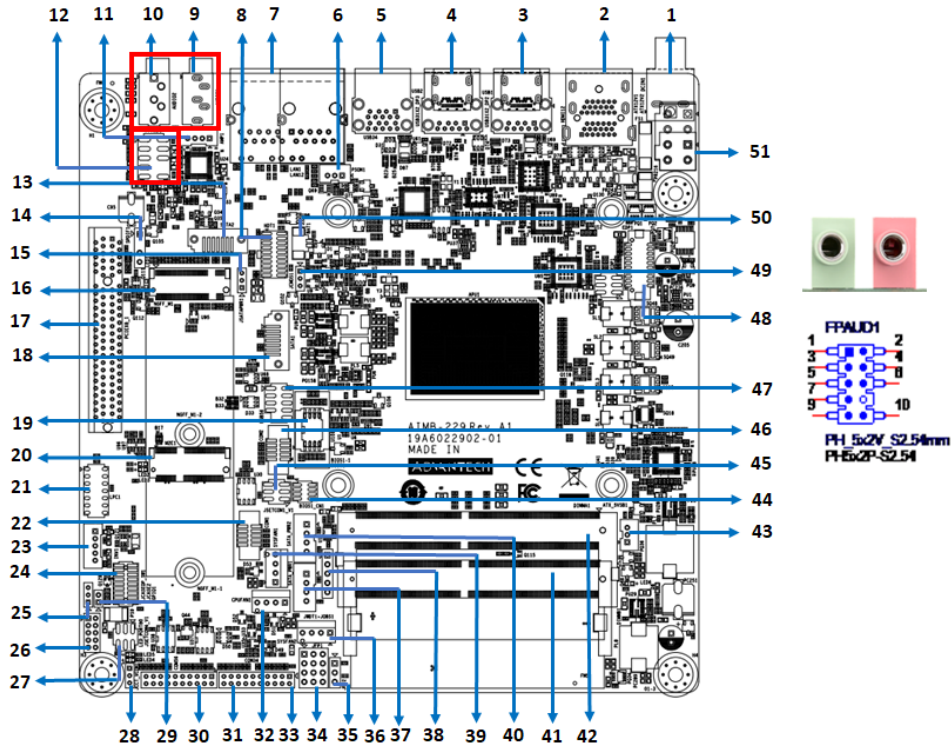

Note! For motherboards with the optional HD Audio feature, we recommend connecting a high-definition front-panel audio module to this connector to take advantage of the motherboard's high-definition audio capability.



2.11 PCI-E x8 Slot (PCIEX8_1)

AIMB-229 provides 1 x PCI express x8 slot.

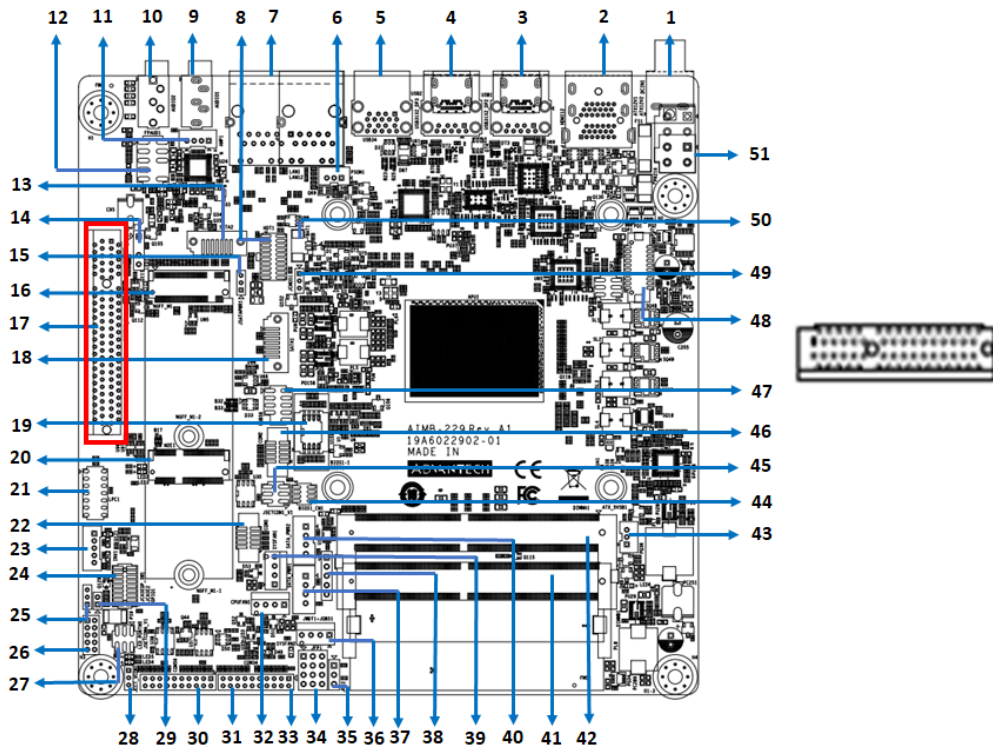

2.12 Low-Voltage Differential Signaling Interface (EDP1)

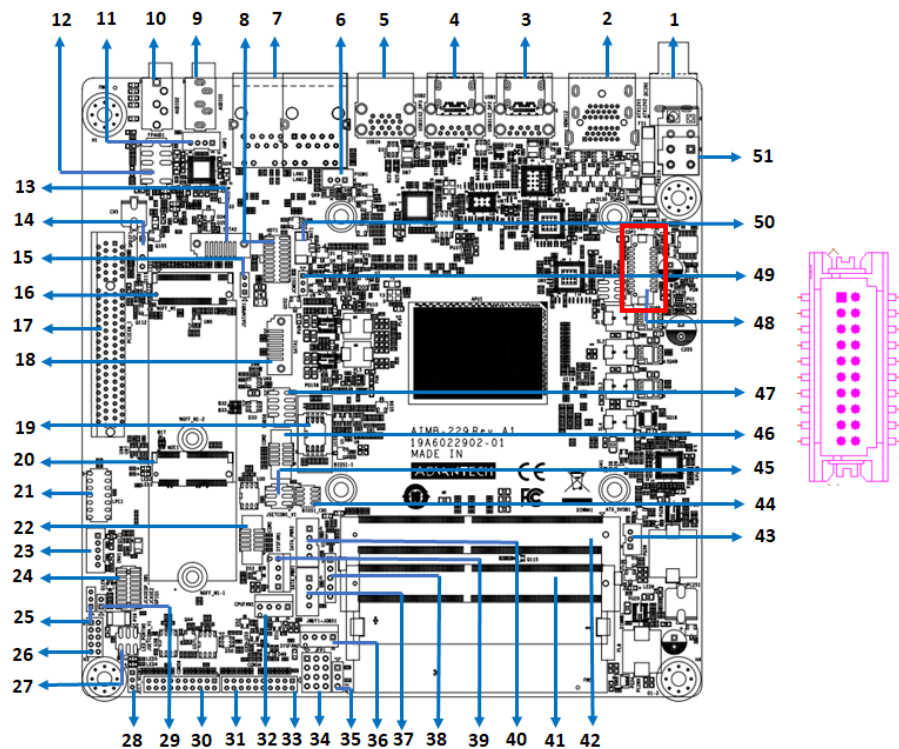

2.13 LVDS Backlight Inverter Power Connector (INV1)

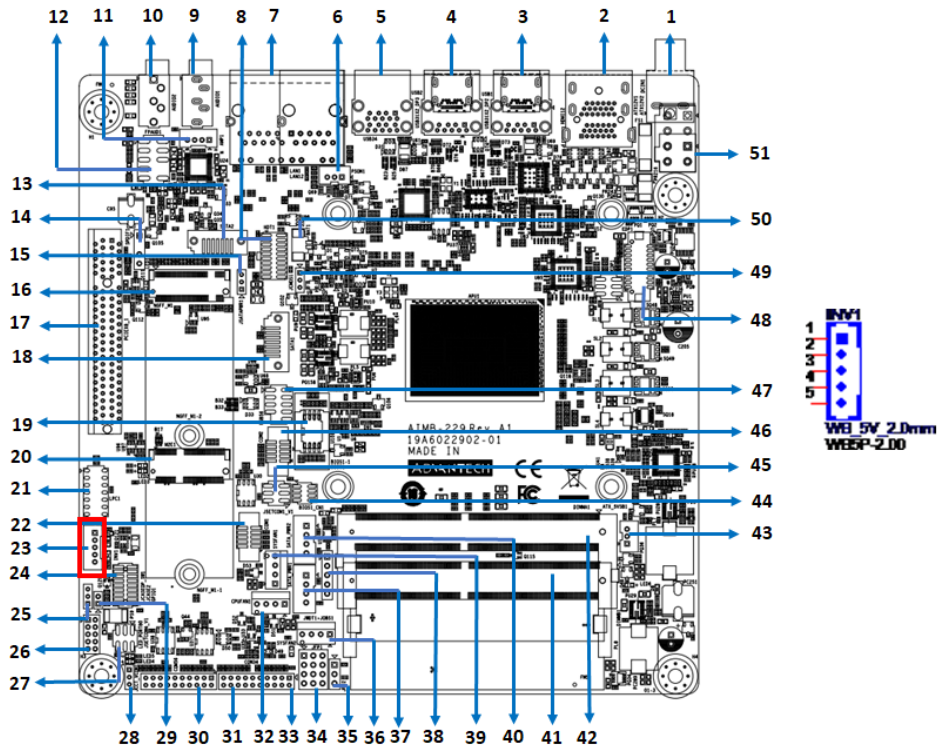

2.14 NGFF M.2 B-Key and E-Key Connector (M2B1 & M2E1)

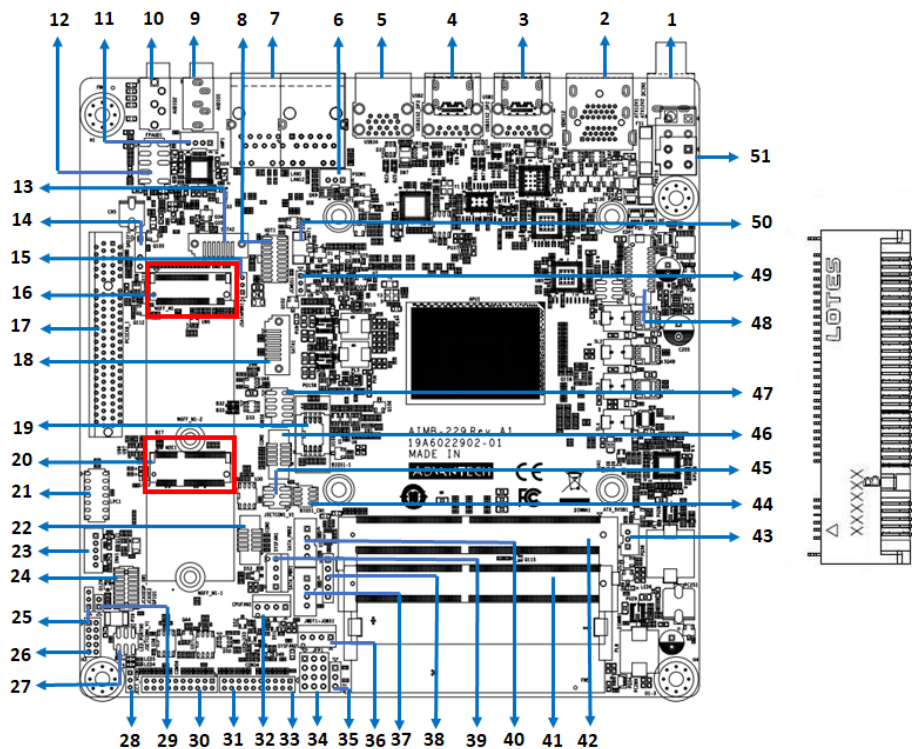

2.15 Audio Amplifier Output Connector (AMP1), BOM Optional

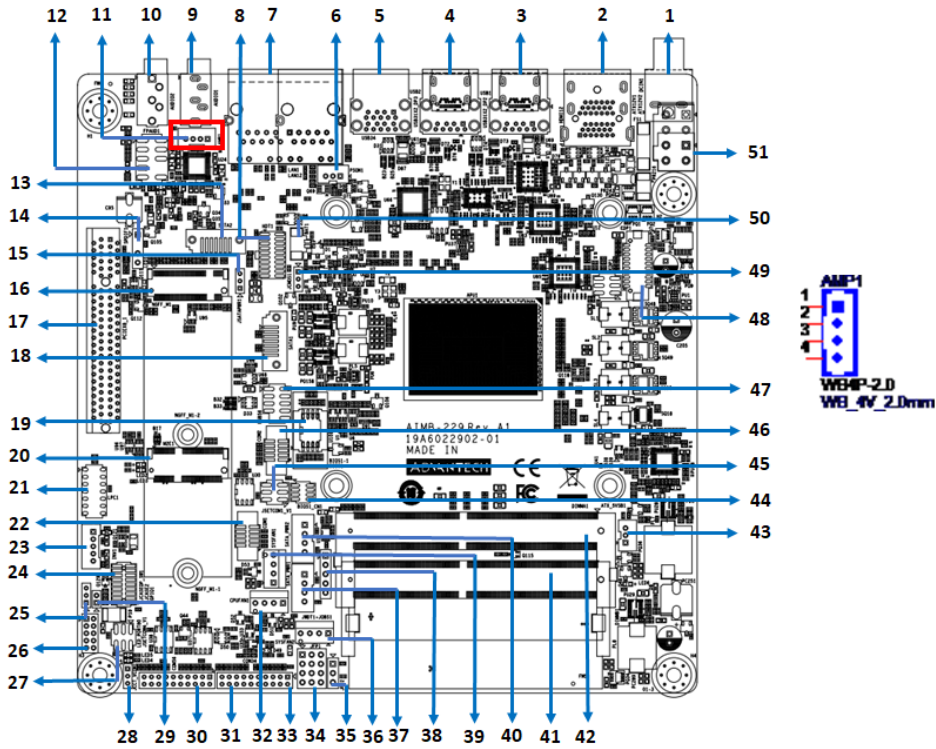

2.16 General Purpose I/O Pin Header (GPIO1)

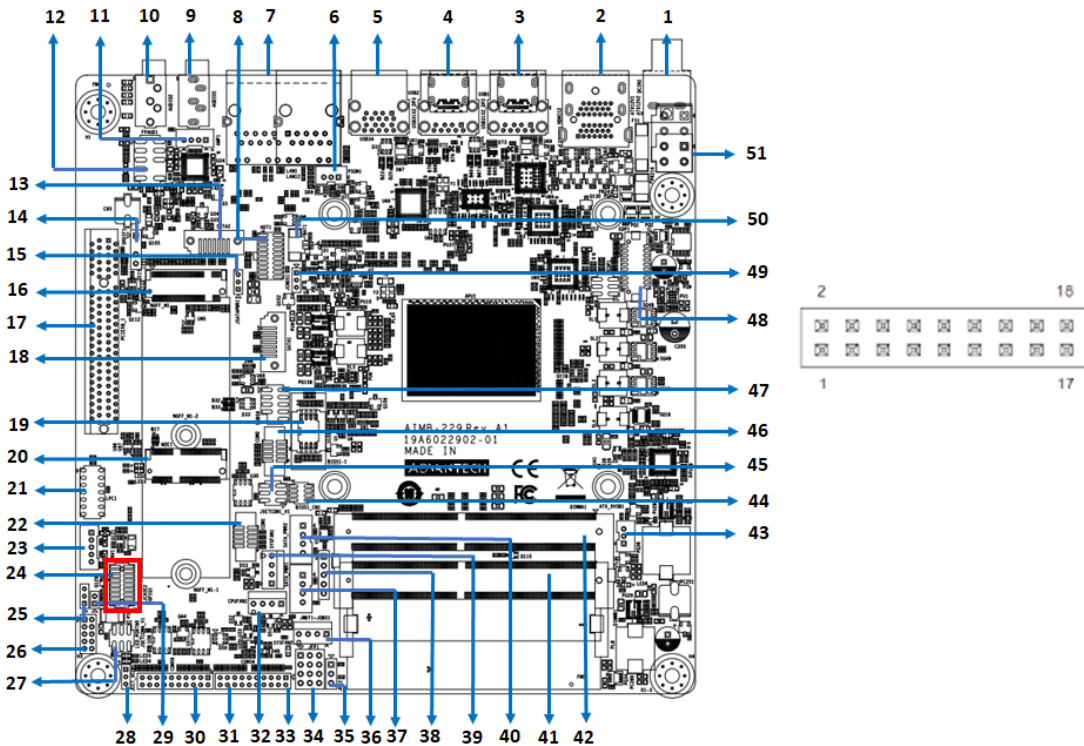

2.17 General Purpose I/O Pin Header (BIOS1)

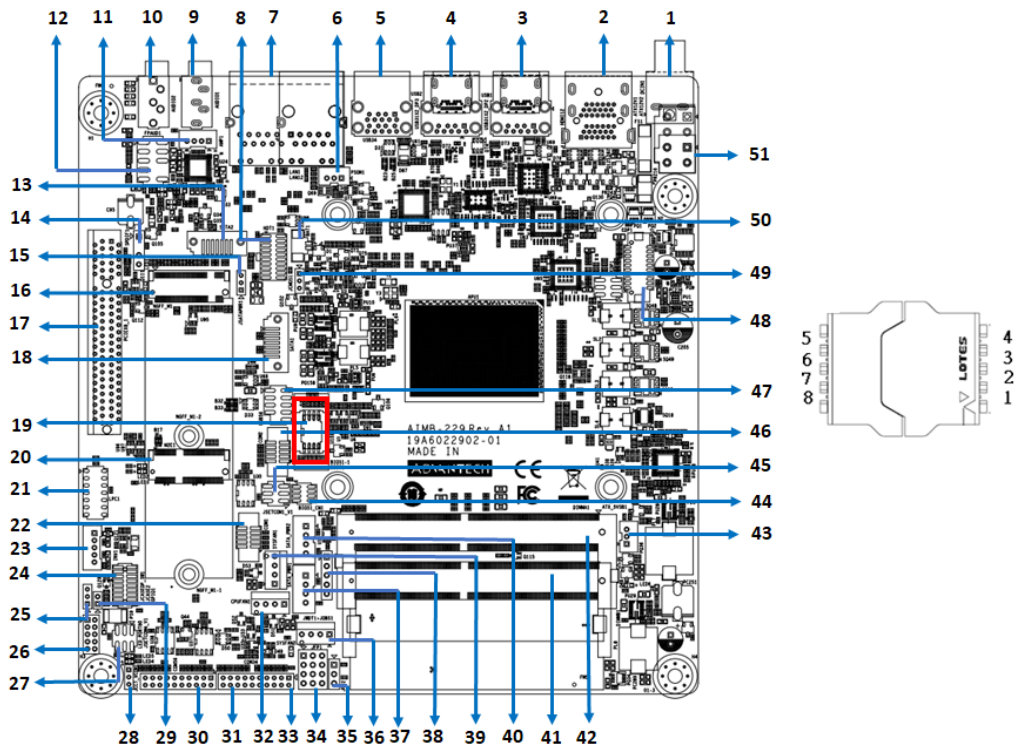

2.18 SPI Programming Pin Header (BIOS1_CN1)

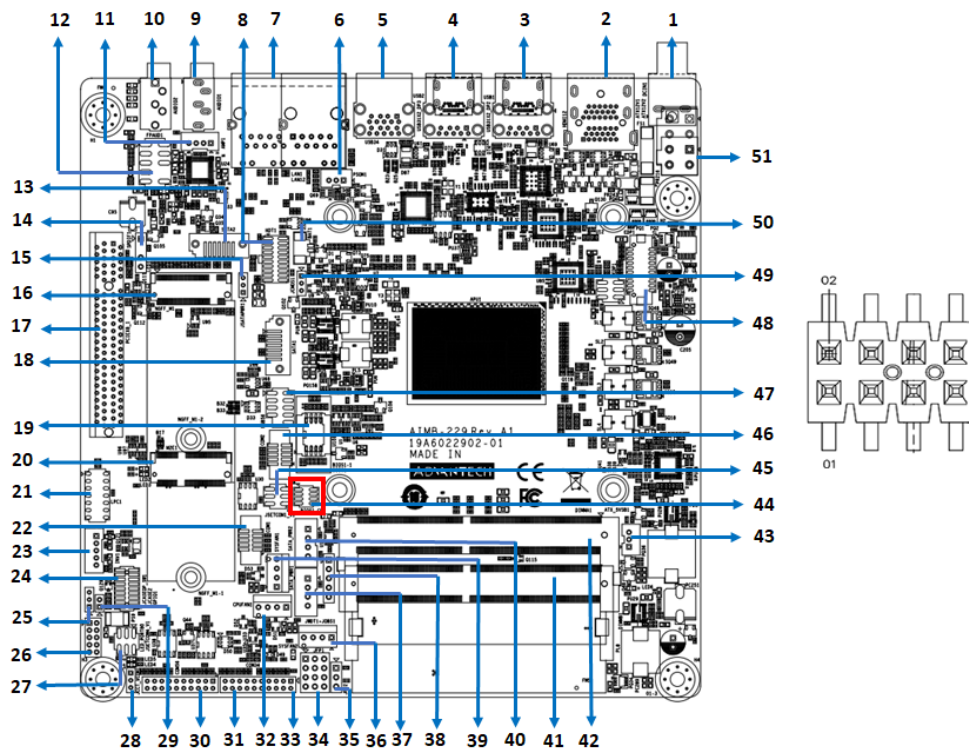

2.19 Low-Pin-Count Header (LPC1)

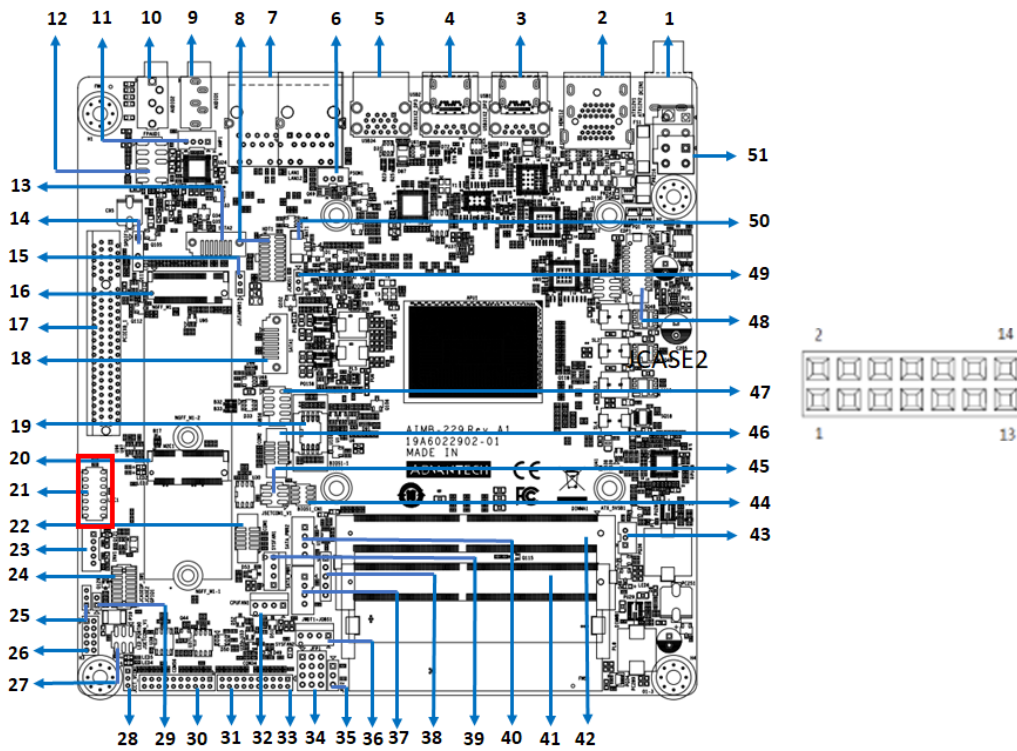

2.20 Case-Open Detect Connector (JCASE2)

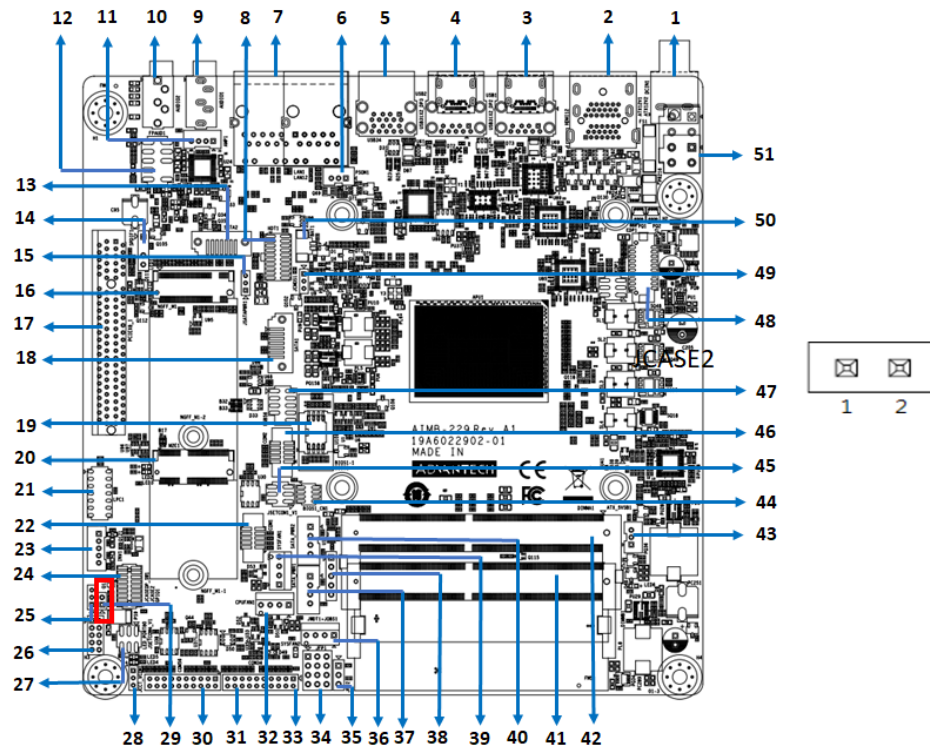

2.21 CMOS Battery Connector (BAT1)

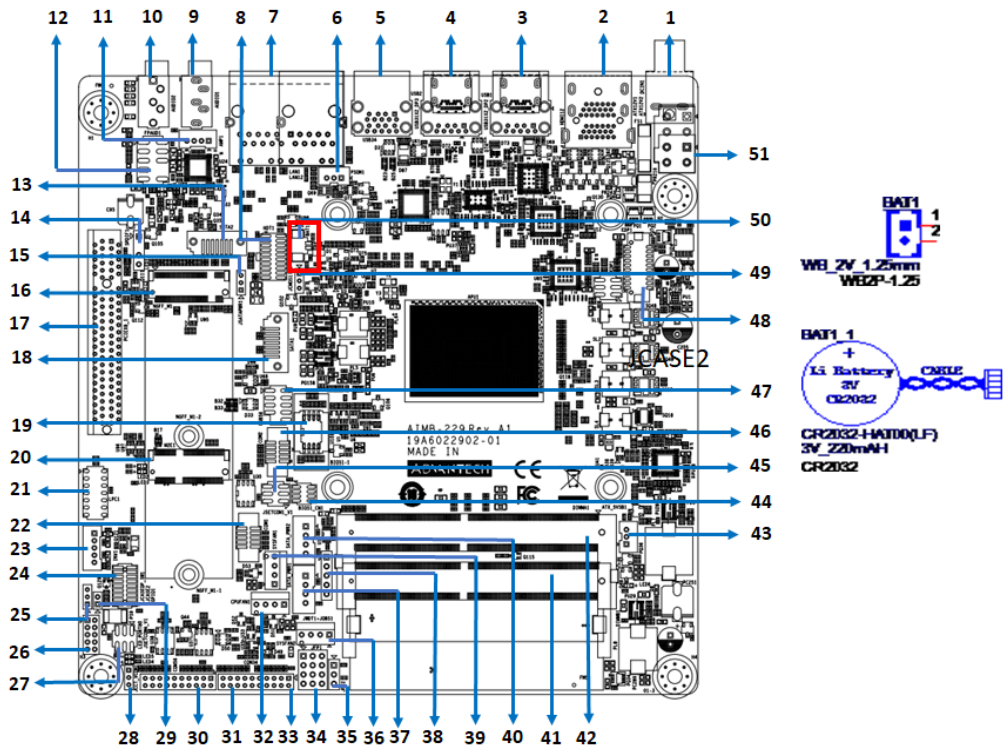

2.22 DDR4 SODIMM Socket (DIMMA1, DIMMB1)

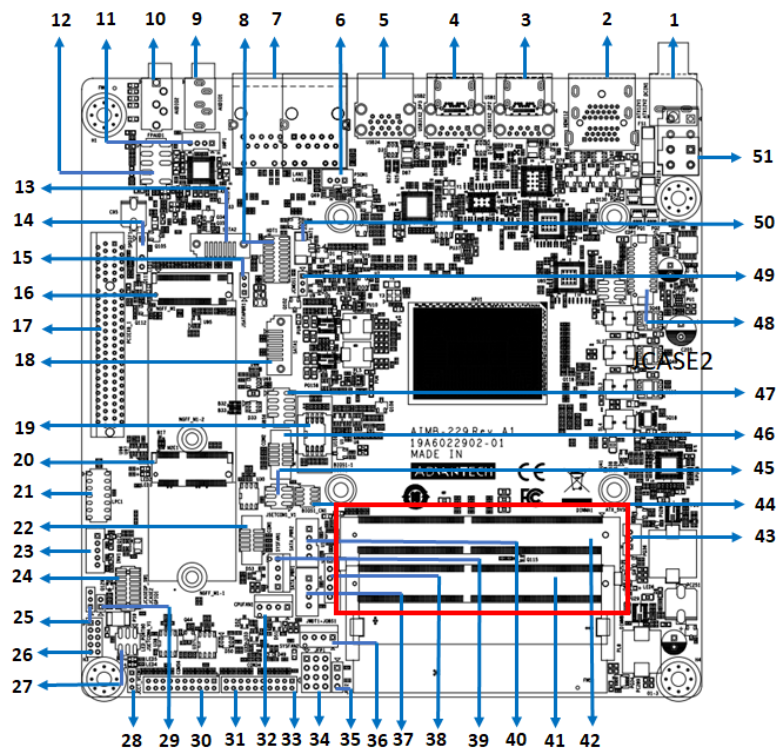

Chapter 3

BIOS Operation

3.1 Introduction

With the AMI BIOS Setup program, users can modify the BIOS settings and control the device configuration. The Setup program features a number of menus for making changes and turning special features on or off. This chapter describes the basic navigation of the AIMB-229 BIOS menus.

3.2 BIOS Setup

The AIMB-229 system has AMI BIOS built in and features a CMOS SETUP utility that allows users to configure required settings or activate certain features. The CMOS SETUP saves the configuration in the CMOS RAM of the motherboard. When the power is turned off, the battery on the board supplies the necessary power to preserve the CMOS RAM.

When the power is turned on, press the button during the BIOS POST (power-on self test) to access the CMOS SETUP screen.

Control Keys

< ↑ >< ↓ >< ← >< → >	Move to select item
<Enter>	Select Item
<Esc>	Exit
<Page Up/+>	Increase the numeric value or make changes
<Page Down/->	Decrease the numeric value or make changes
<F1>	General help, for Setup sub menu
<F2>	Previous values
<F3>	Optimized Defaults
<F4>	Save & Exit

3.2.1 Main Menu

Press to enter the AMI BIOS CMOS Setup Utility. The Main menu will appear onscreen. Use the arrow keys to select an item and press <Enter> to accept or enter the sub-menu.



The Main BIOS setup screen has two main frames. The left frame displays all the options that can be configured. Grayed-out options cannot be configured, whereas options in blue can be configured. The right frame displays the key legend.

Above the key legend is an area reserved for a text message. When an option is selected in the left frame, it is highlighted in white. Often a text message will accompany it.

- #### System Time/System Date

Use this option to change the system time and date. Highlight System Time or System Date using the <Arrow> keys. Enter new values via the keyboard. Press the <Tab> or <Arrow> keys to move between fields. The date must be entered in MM/DD/YY format. The time must be entered in HH:MM:SS format.

3.2.2 Advanced BIOS Features

Select the Advanced tab from the BIOS setup menu to enter the Advanced BIOS setup screen. Users can select any of the items in the left frame of the screen, such as CPU Configuration, to access the sub-menu for that item. Display an Advanced BIOS setup option by highlighting it using the <Arrow> keys. All Advanced BIOS setup options are described in this section. The Advanced BIOS setup screen is shown below. The sub menus are described in the following sections.

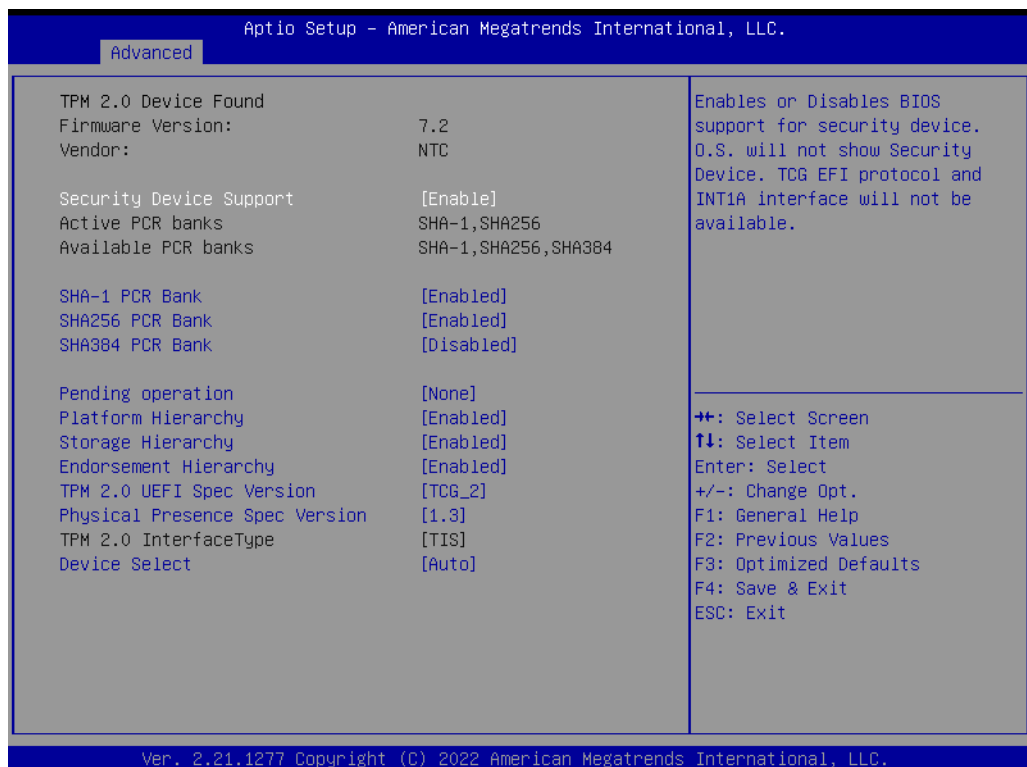
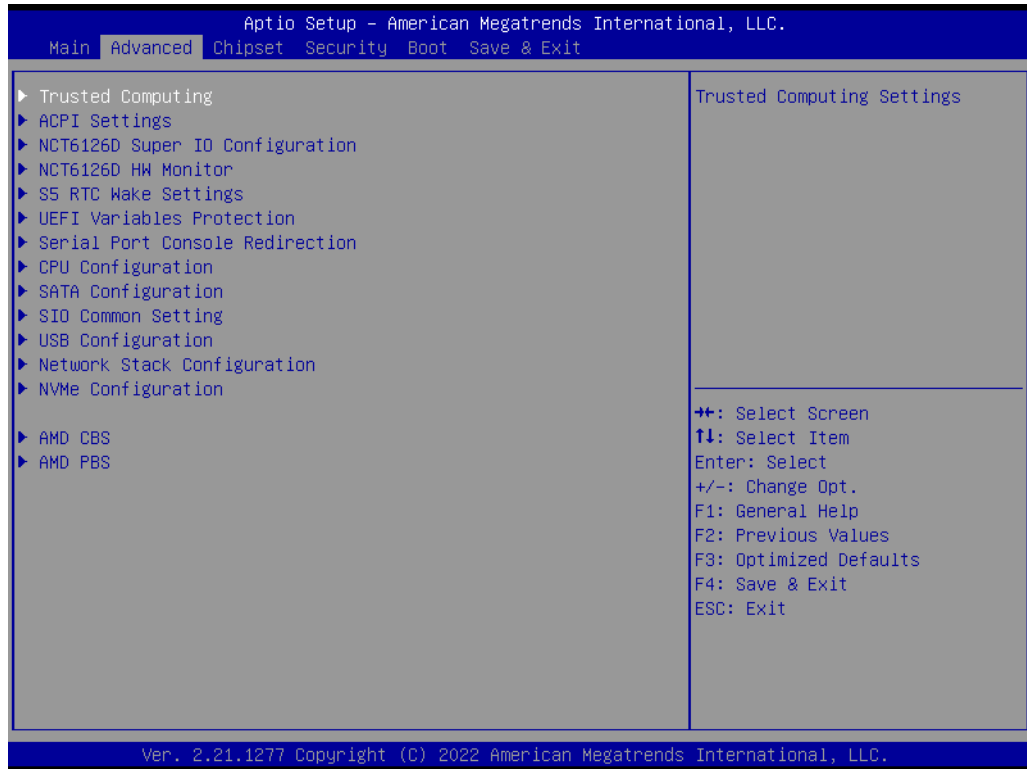

3.2.2.1 Trusted Computing

This item allows users to enable/disable the TPM (TPM 2.0). The TPM (Trusted Platform Module) is a secure key generator and key cache management component that enables protected storage of encryption keys and authentication credentials for enhanced security.

■ Security Device Support [Disable]

Note! *The TCG EFI protocol and INT1A interface will not be available.*



3.2.2.2 ACPI Settings

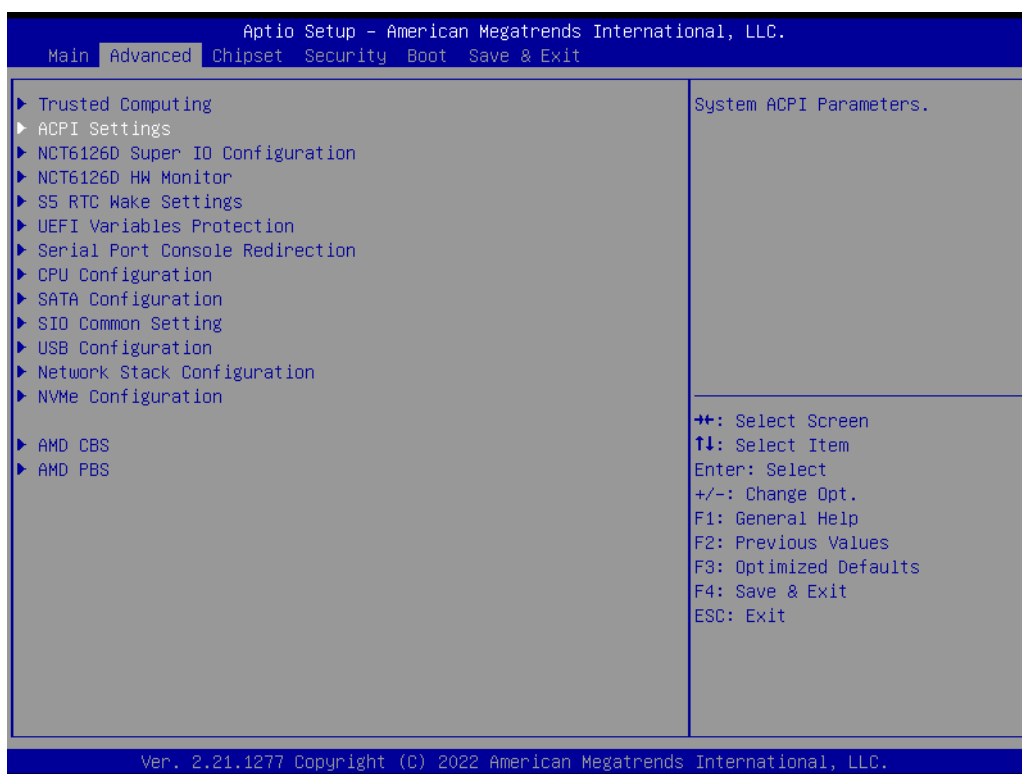

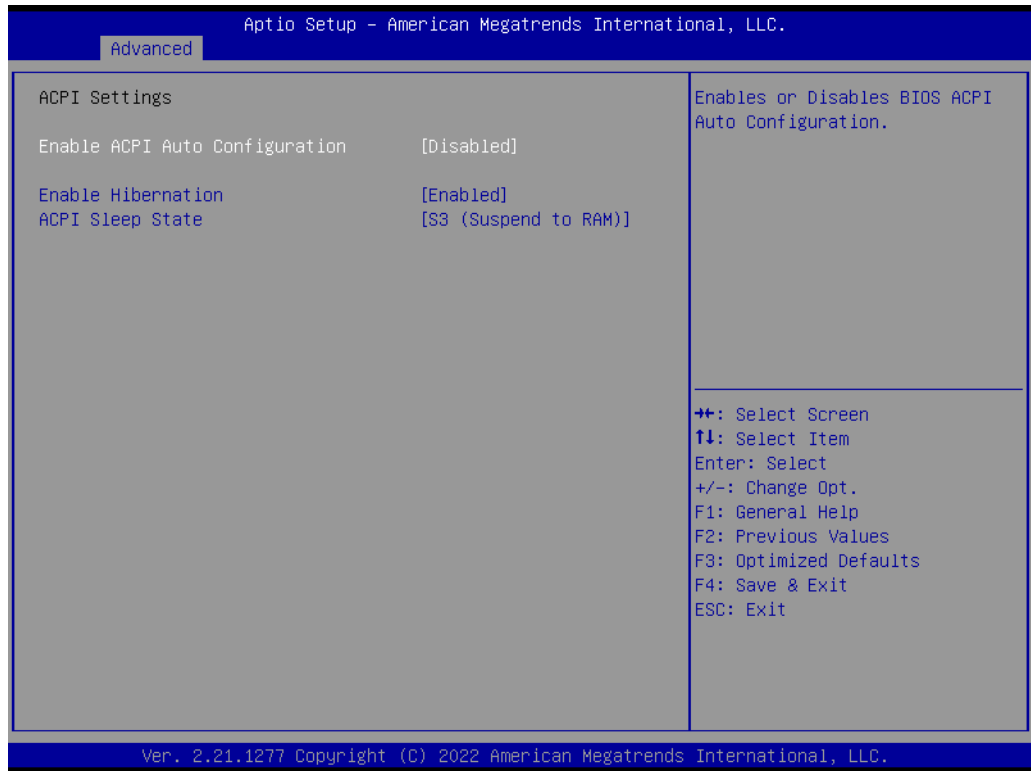

- **Enable ACPI Auto Configuration [Disabled]**
This item allows users to enable/disable BIOS ACPI auto configuration.
- **Enable Hibernation [Enabled]**
This item allows users to enable/disable the Hibernate (OS/S4 sleep state) function. This option may not be available with certain operating systems.
- **ACPI Sleep State [Auto]**
This item allows users to select the ACPI sleep state the system will enter when the SUSPEND button is pressed.

3.2.2.3 NCT6126D Super IO Configuration

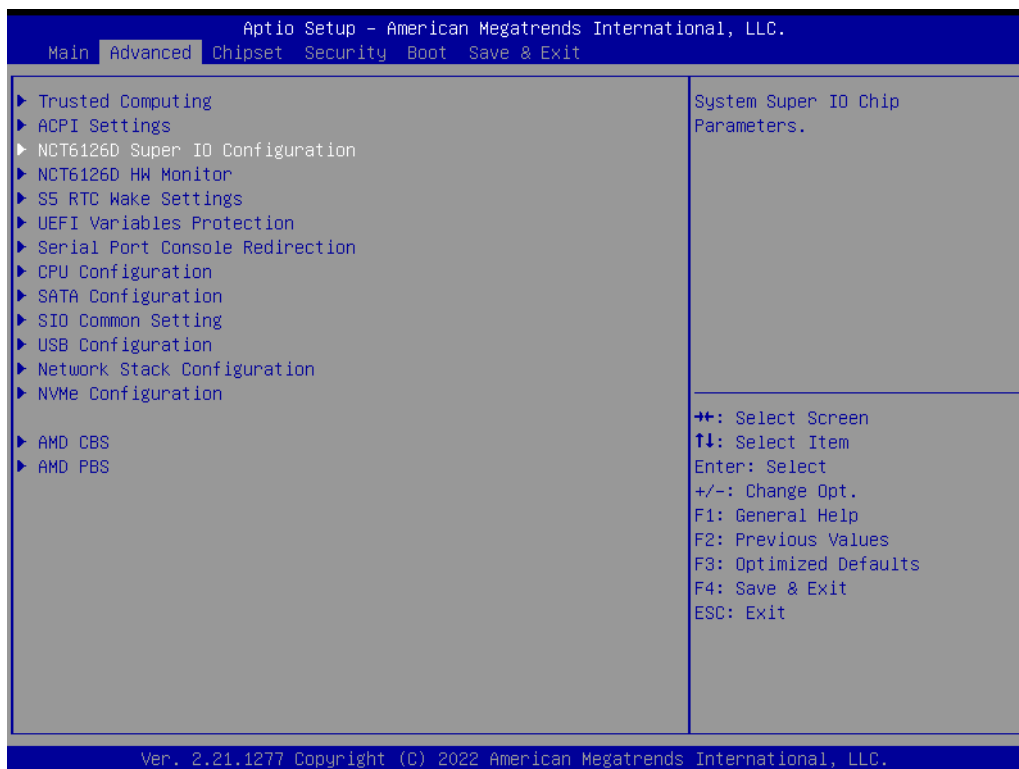

3.2.2.4 Super IO Chip [NCT6126D]

■ Serial Port 1 Configuration

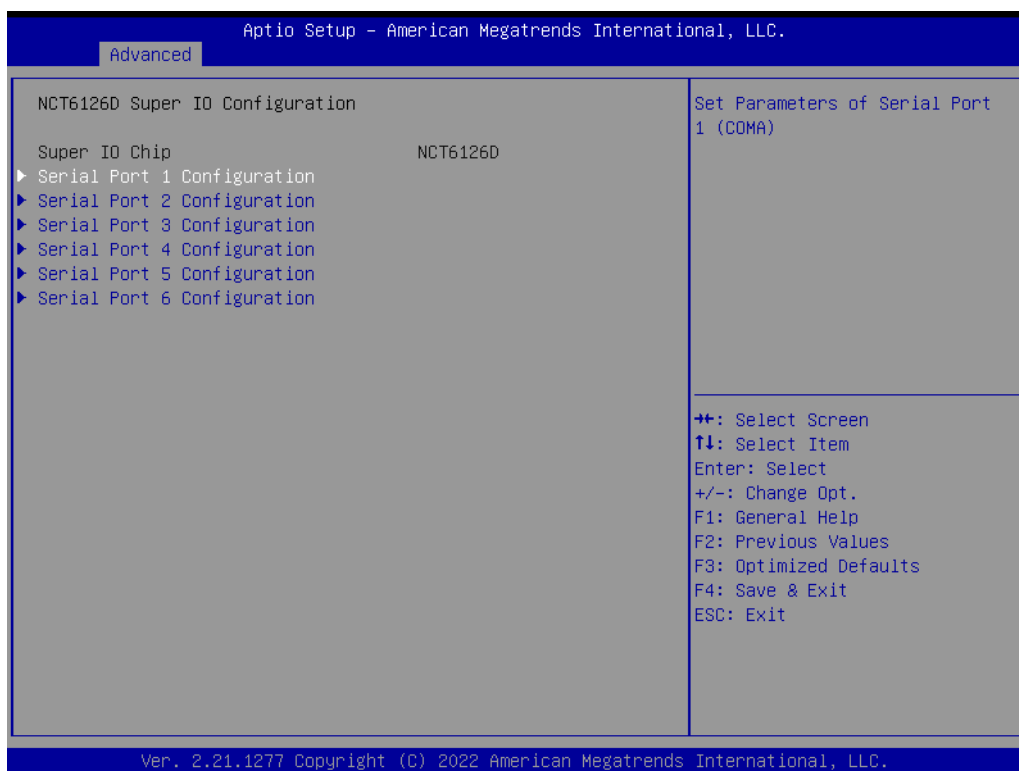

- **Serial Port [Enabled]**

- **Device Settings: IO = 3F8h; IRQ = 4**
- **Change Settings [Auto]**

This item allows users to select the optimal settings for serial port 1.

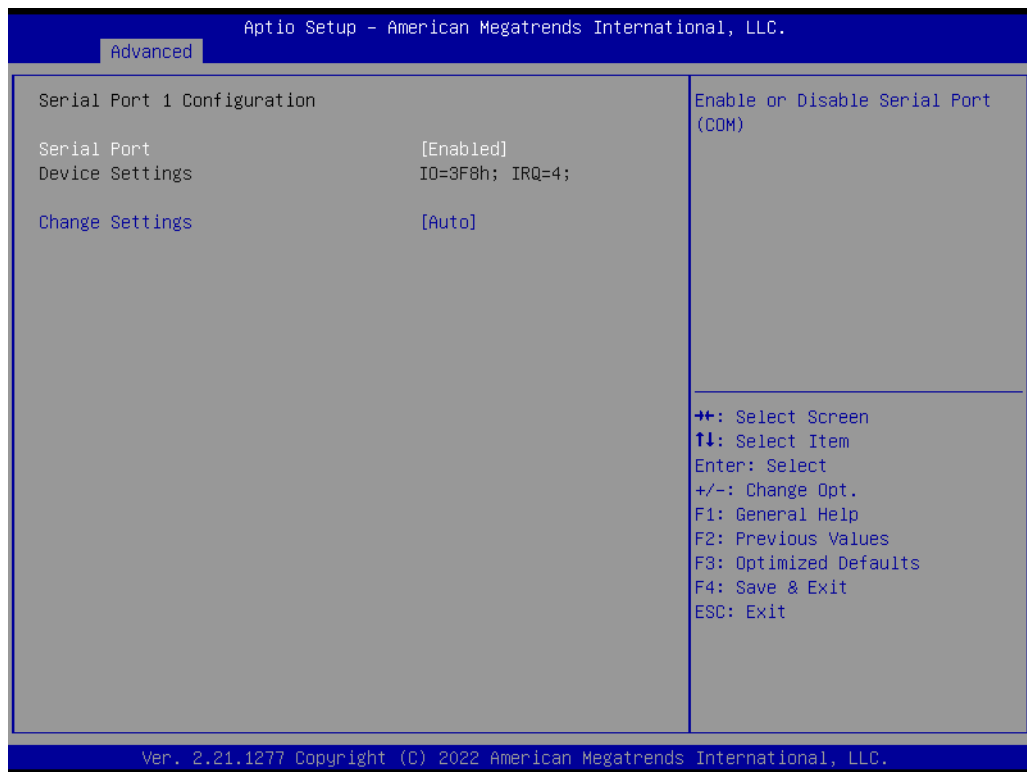

- **Serial Port 2 Configuration**

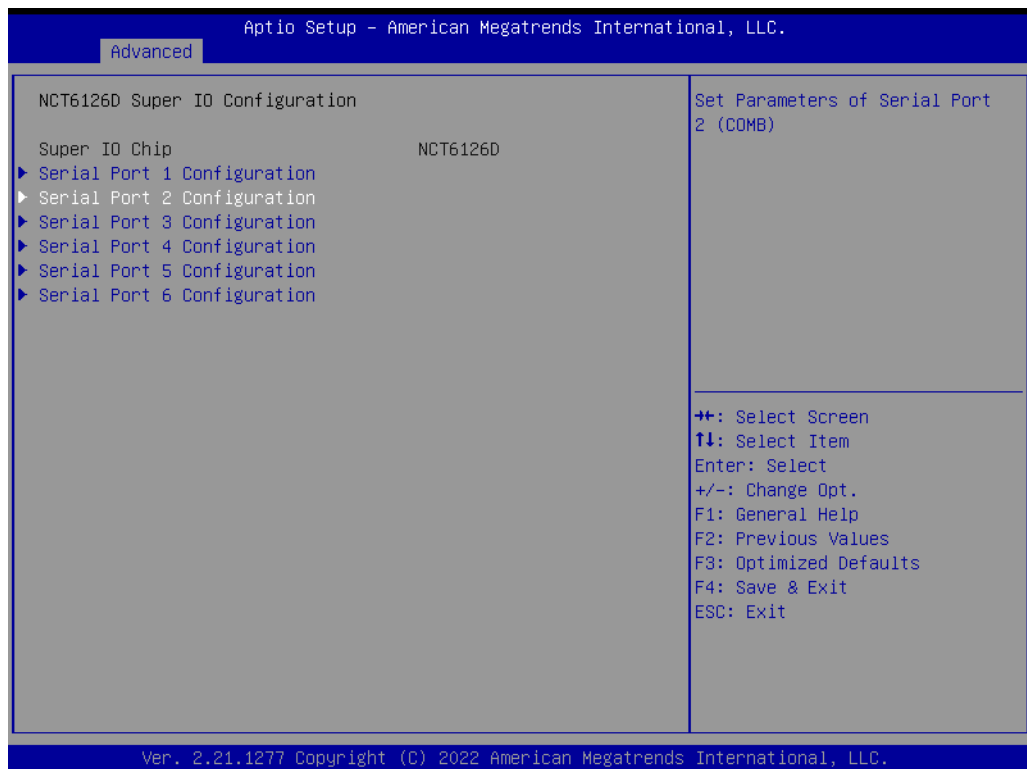

- **Serial Port [Enabled]**
 - **Device Settings: IO = 2F8h; IRQ = 3**
 - **Change Setting [Auto]**

This item allows users to select the optimal settings for serial port 2.



- **Serial Port 3 Configuration**

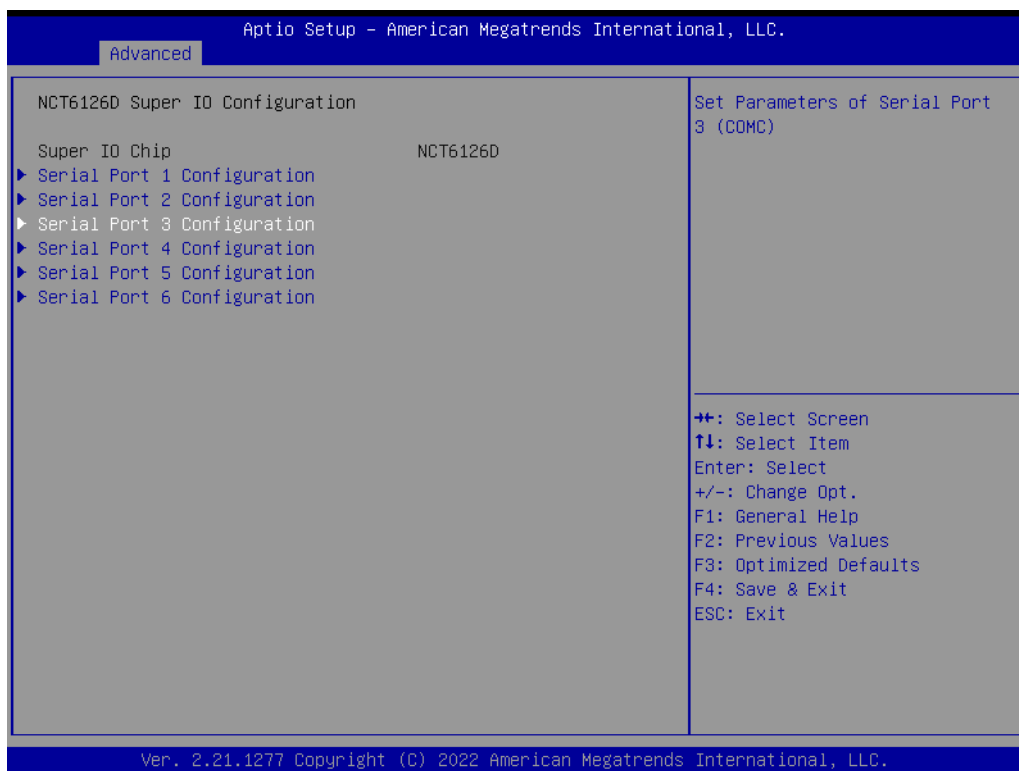

- **Serial Port [Enabled]**

- **Device Settings: IO = 3E8h; IRQ = 5**
- **Change Setting [Auto]**

This item allows users to select the optimal settings for serial port 3.

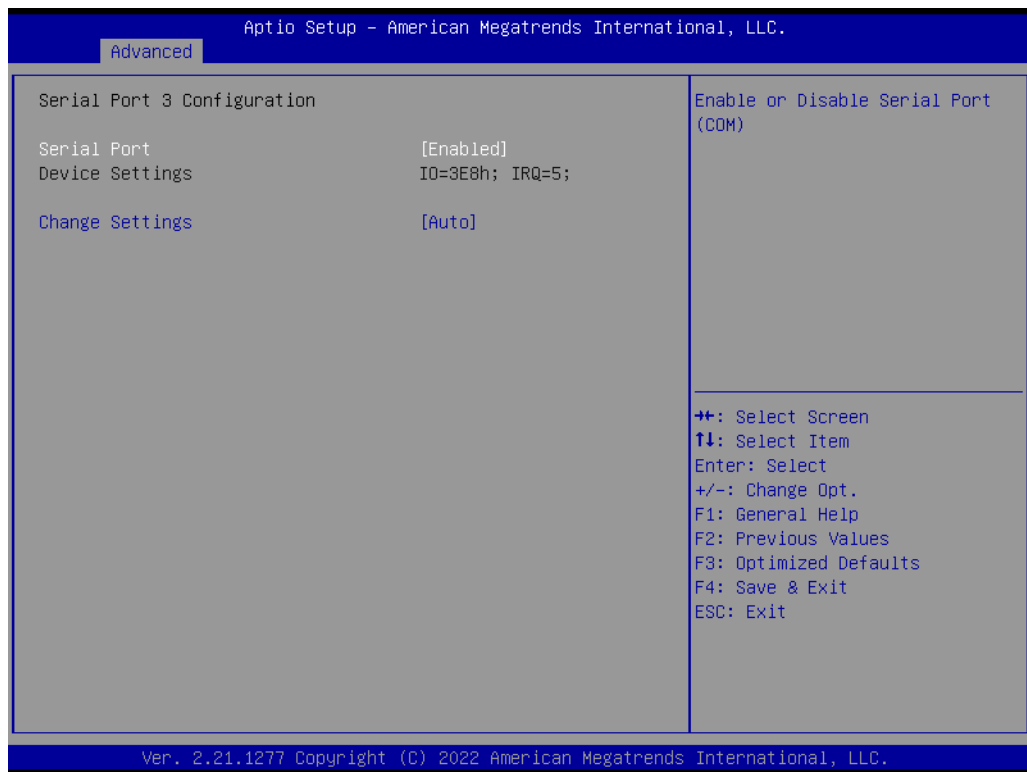

- **Serial Port 4 Configuration**

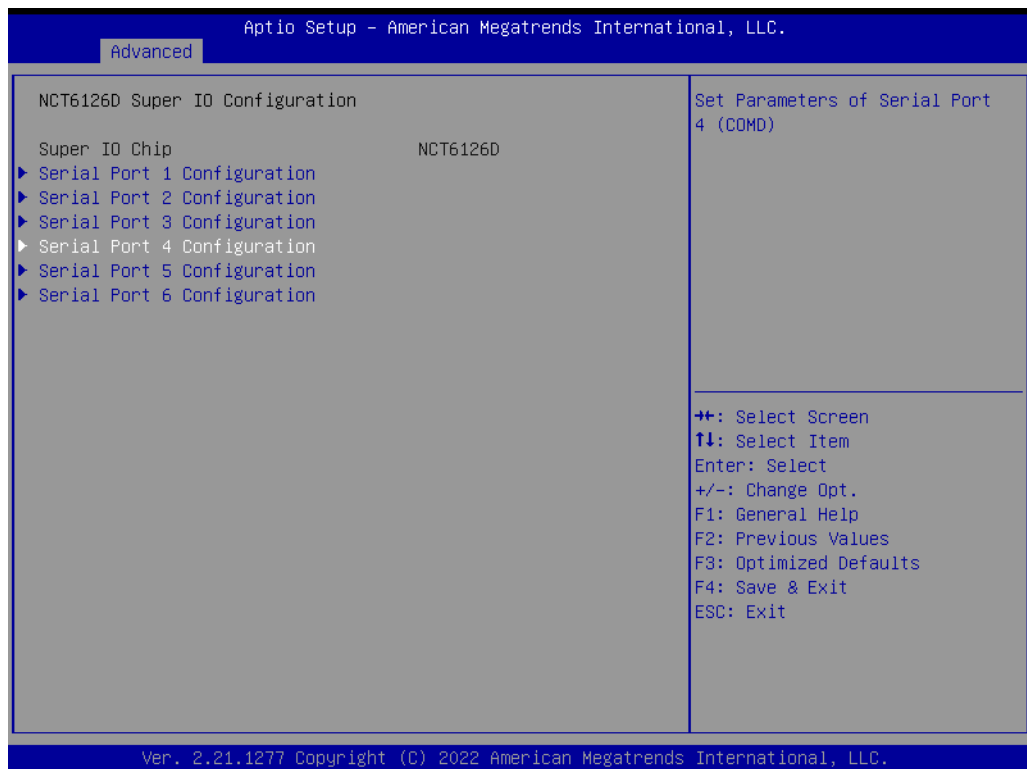

- **Serial Port [Enabled]**
 - **Device Settings: IO = 2E8h; IRQ = 5**
 - **Change Setting [Auto]**

This item allows users to select the optimal settings for serial port 4.

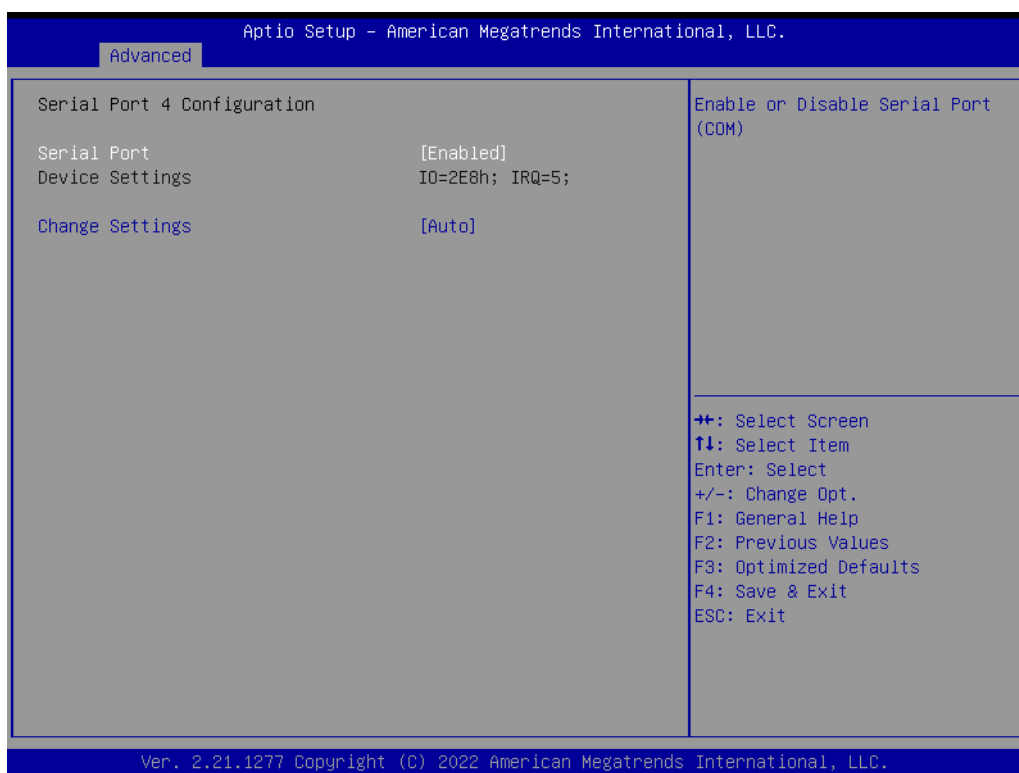

- **Serial Port 5 Configuration**

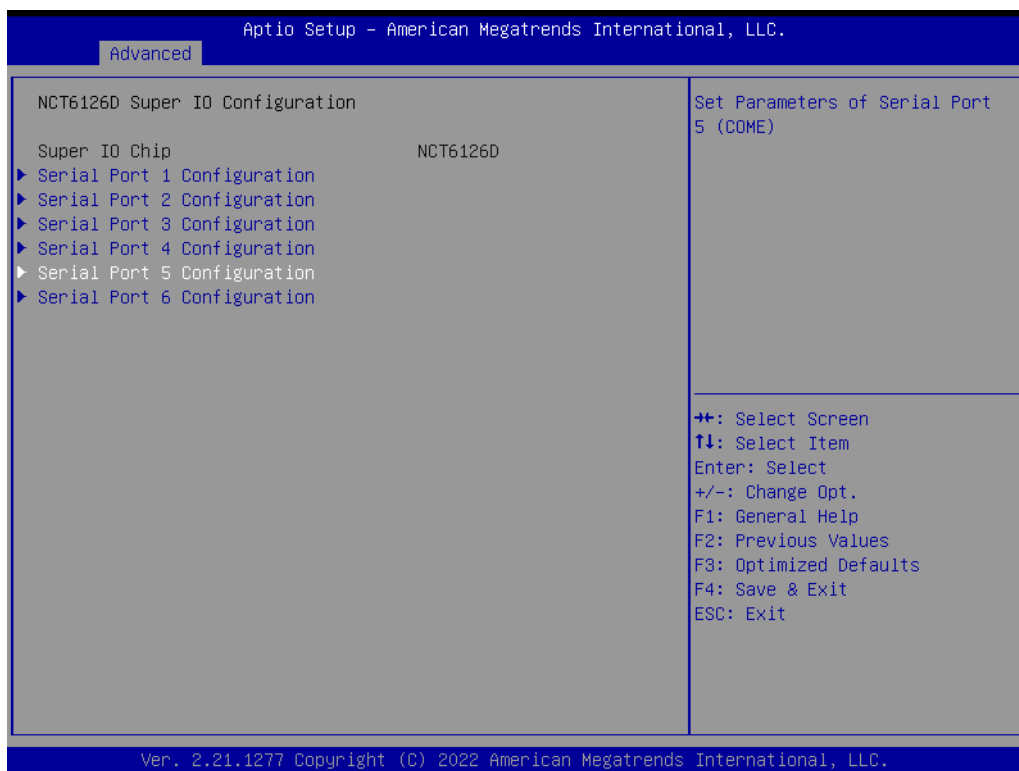

- **Serial Port [Enabled]**

- **Device Settings: IO = 220h; IRQ = 11**
- **Change Setting [Auto]**

This item allows users to select the optimal settings for serial port 5.



- **Serial Port 6 Configuration**

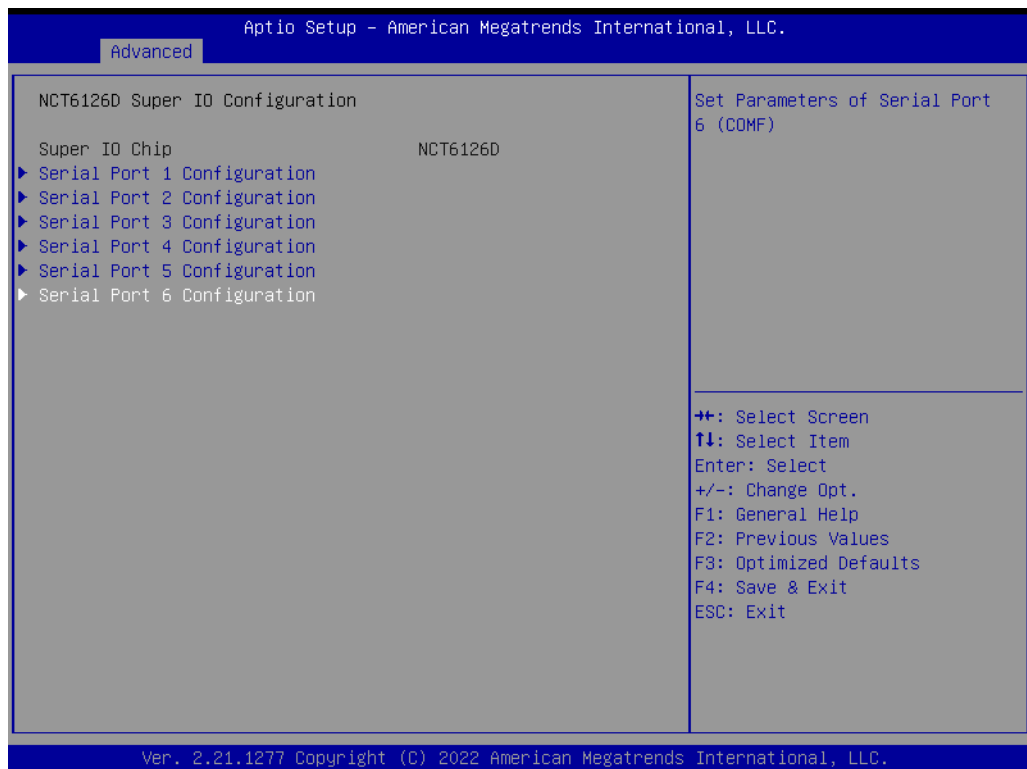

- **Serial Port [Enabled]**
 - **Device Settings: IO = 228h; IRQ = 11**
 - **Change Setting [Auto]**

This item allows users to select the optimal settings for serial port 3.



3.2.2.5 NCT6126D HW Monitor

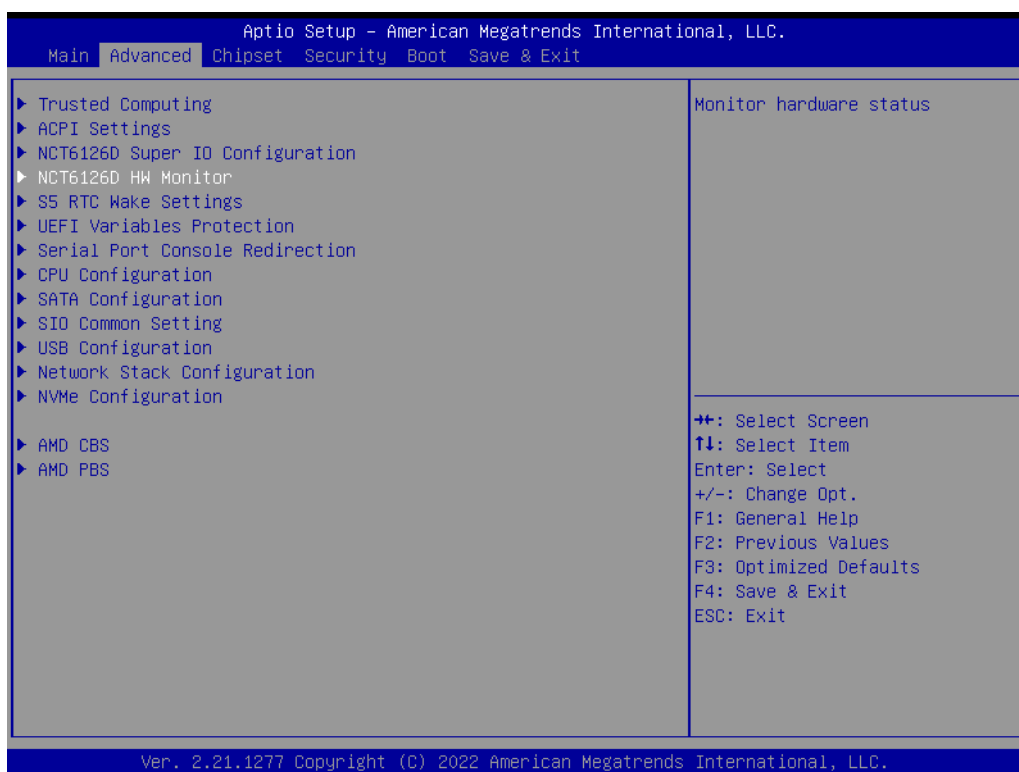

■ Smart Fan Function

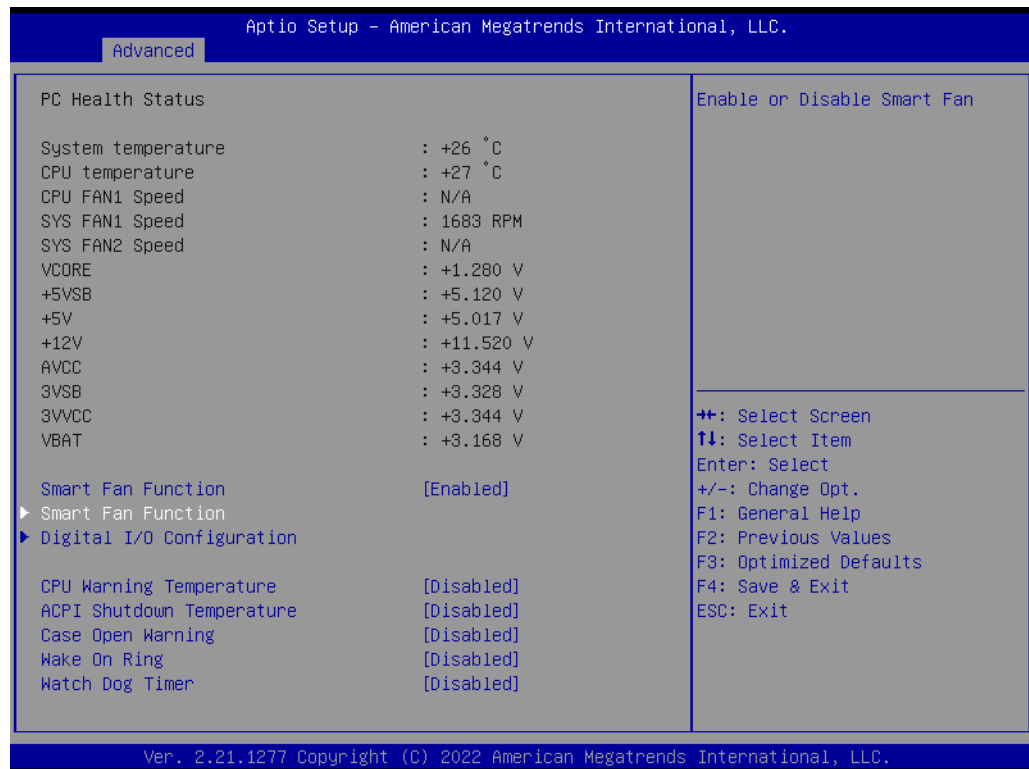

■ CPU Fan1 Mode [SMART FAN IV Mode]

This item allows users to view the CPU temperature and fan speed (PWM) information.

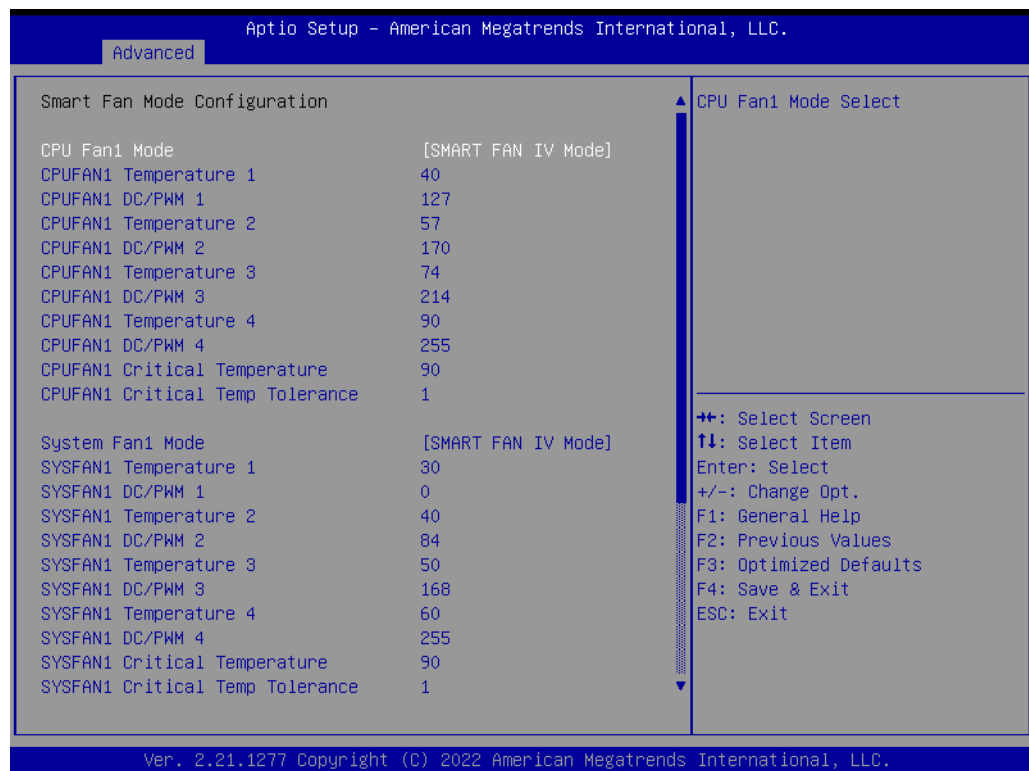

■ CPU Fan2 Mode [SMART FAN IV Mode]

This item allows users to view the CPU temperature and fan speed (PWM) information.

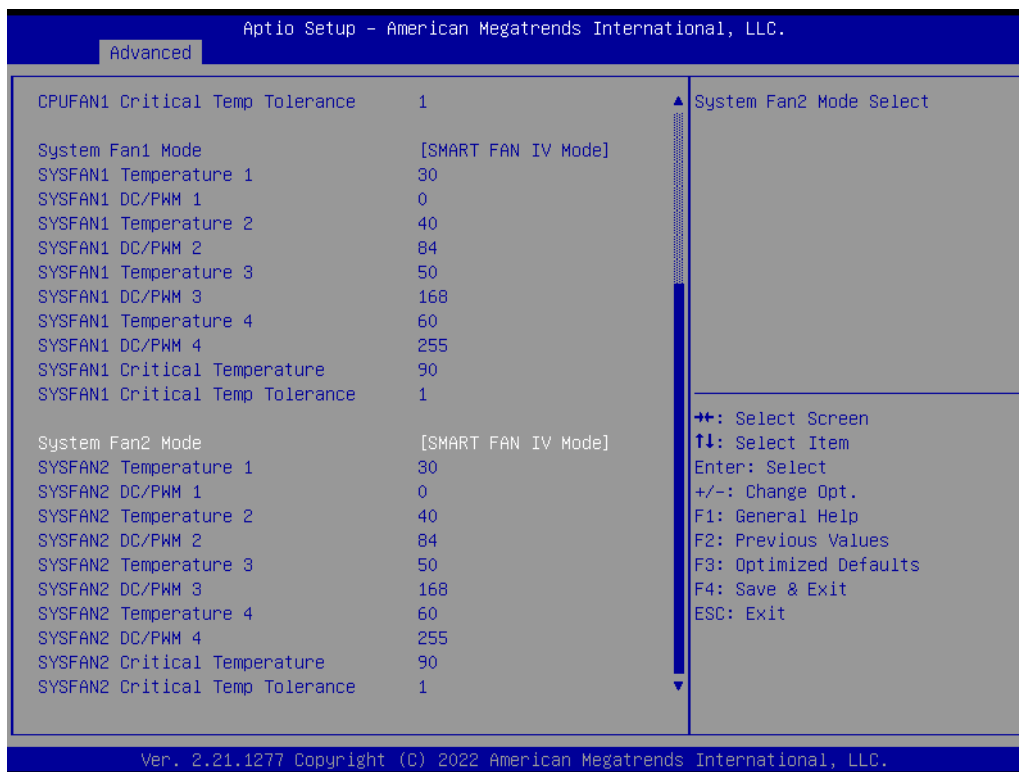

■ Digital I/O Configuration

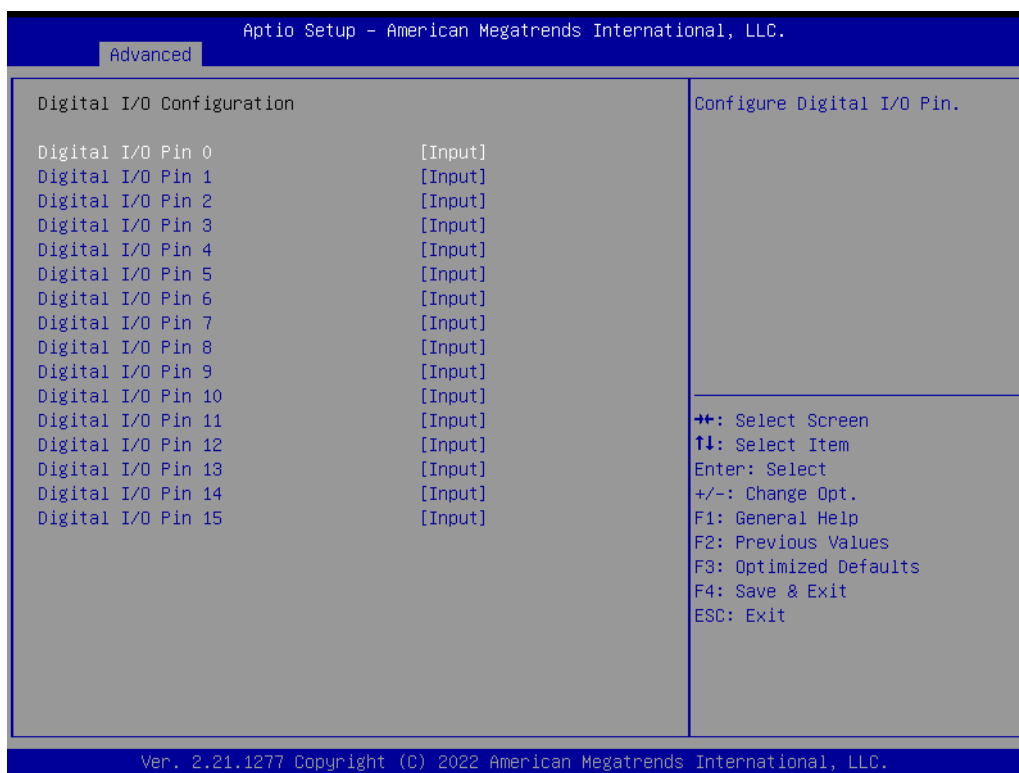

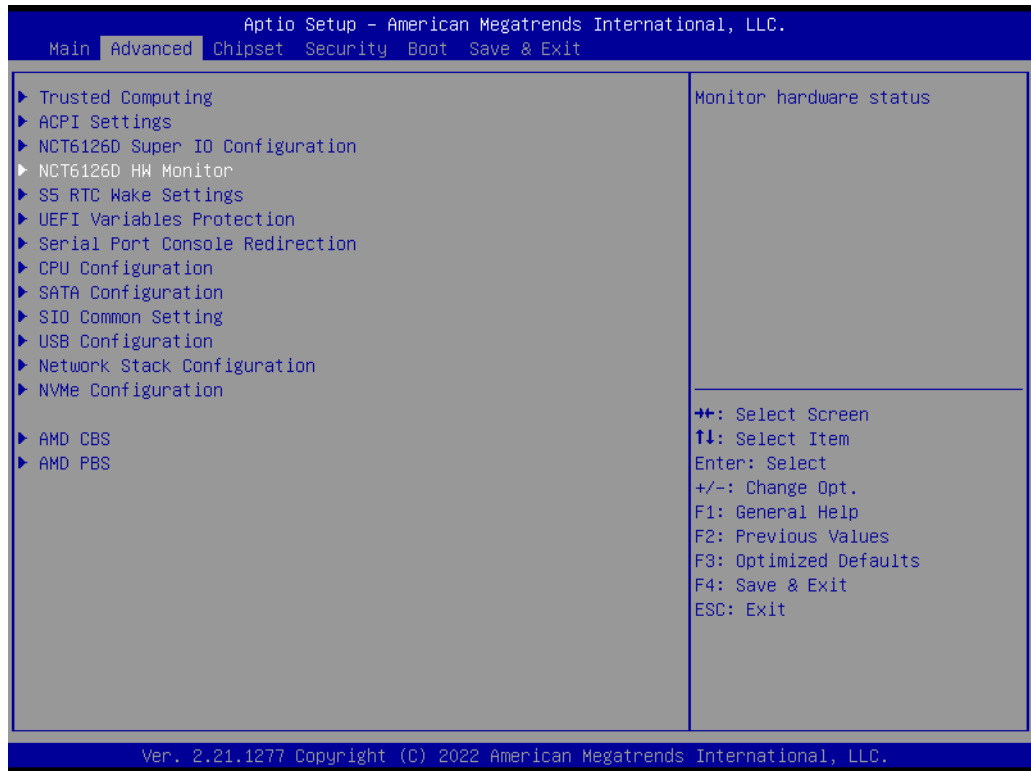

- **CPU Warning Temperature [Disabled]**
This item allows users to enable/disable the CPU warning temperature function and set the threshold value. When the system reaches the warning temperature, the system will emit an alarm.
- **ACPI Shutdown Temperature [Disabled]**
This item allows users to enable/disable the ACPI shutdown temperature function and set the threshold value. When the system reaches the shutdown temperature, it will automatically shut down to protect the system from over-heating damage.

3.2.2.6 S5 RTC Wake Settings

This item allows users to enable/disable the system-wake-on-alarm function.

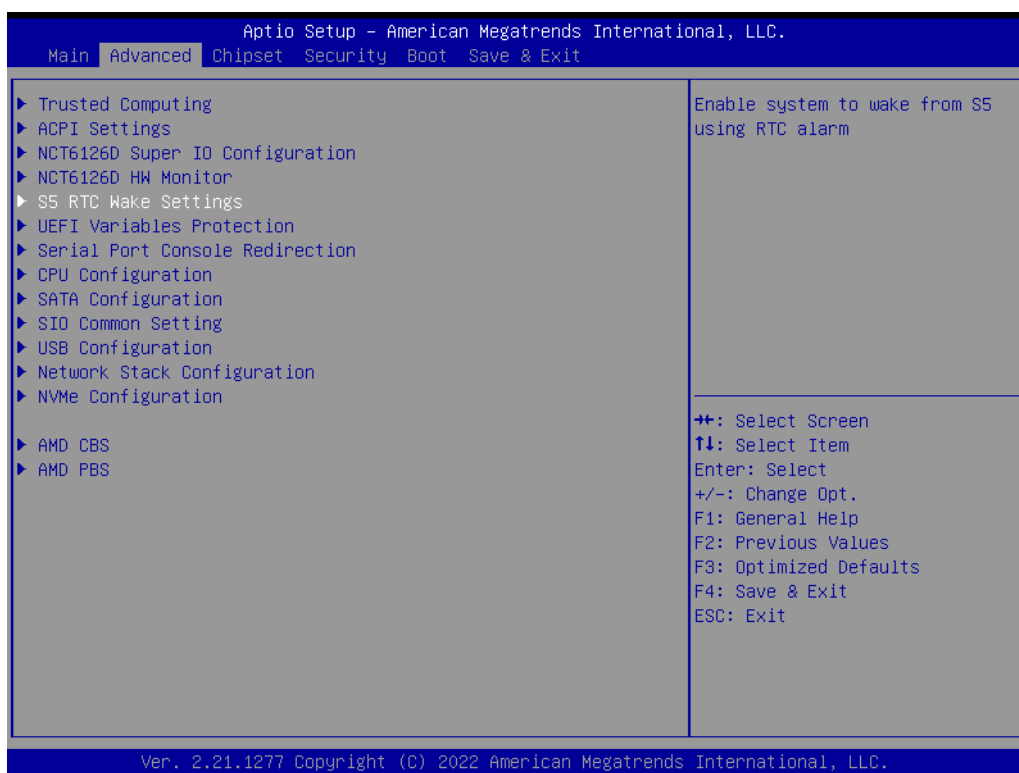

■ Wake System with Fixed Time [Disabled]

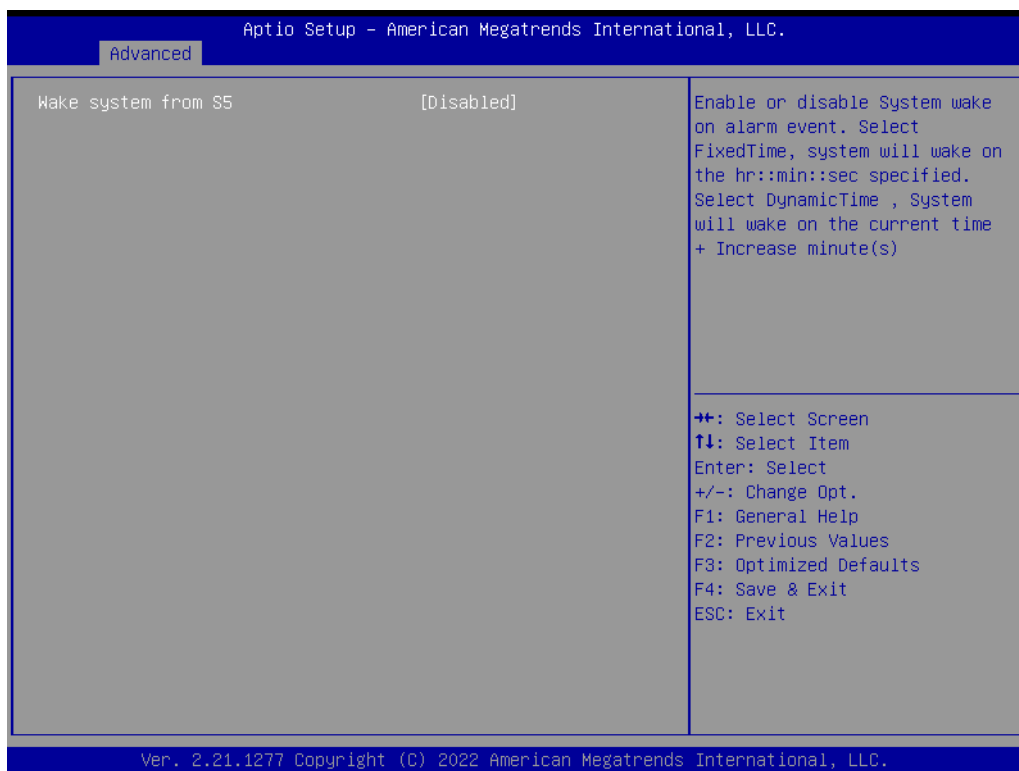

Note! When enabled, the system will wake at the specified time.



3.2.2.7 Serial Port Console Redirection

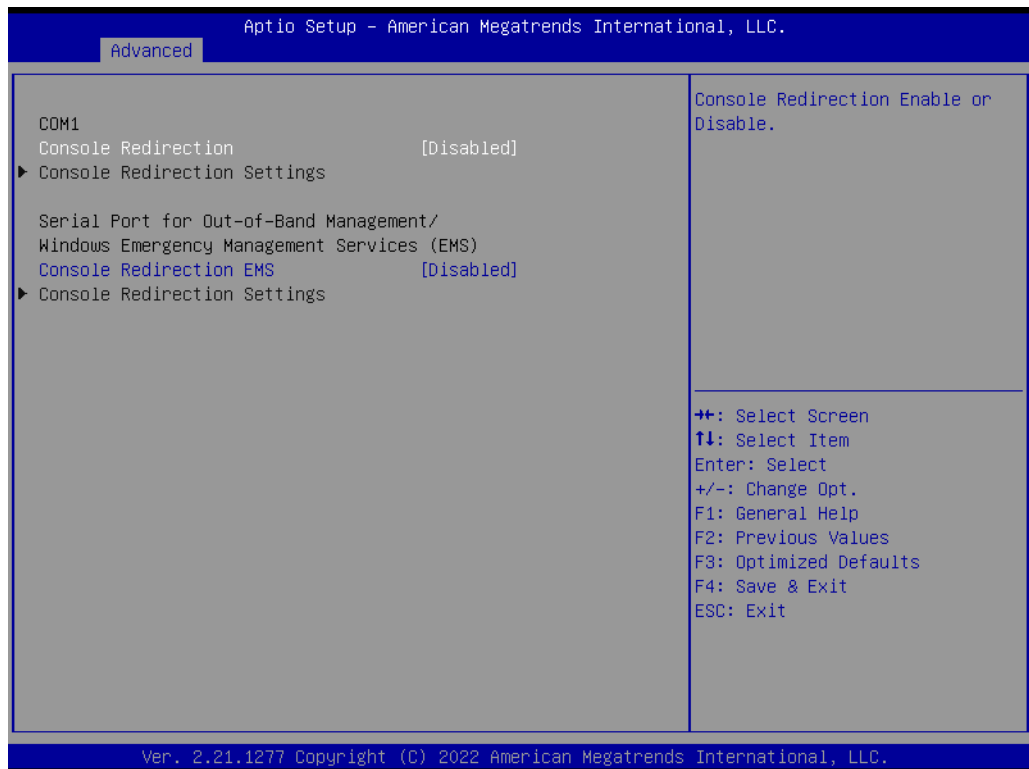
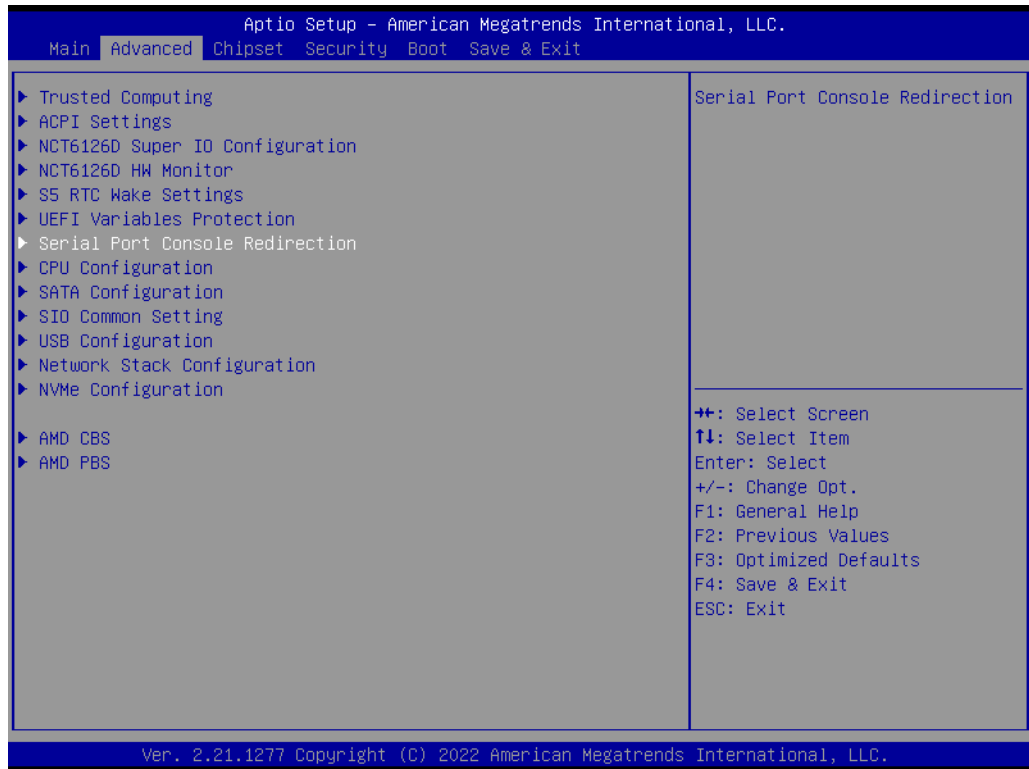

- **Console Redirection [Disabled]**
This item allows users to enable/disable the console redirect function.

3.2.2.8 Network Stack Configuration [Disabled]

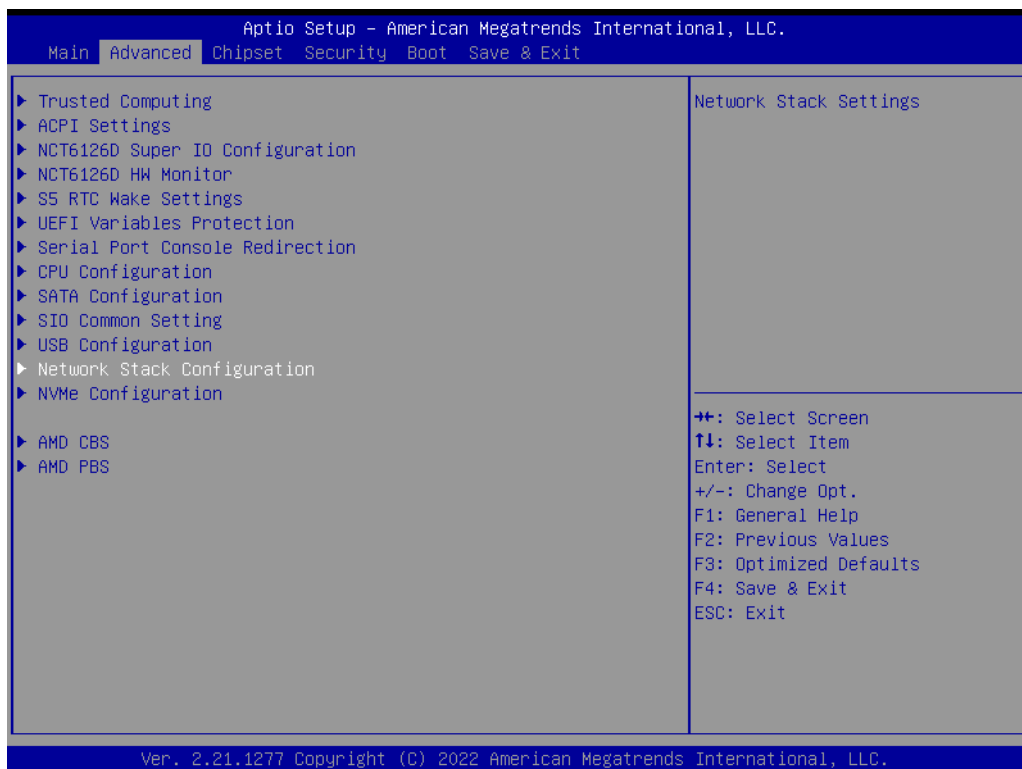

■ Network Stack [Disabled]

3.2.2.9 UEFI Variables Protection

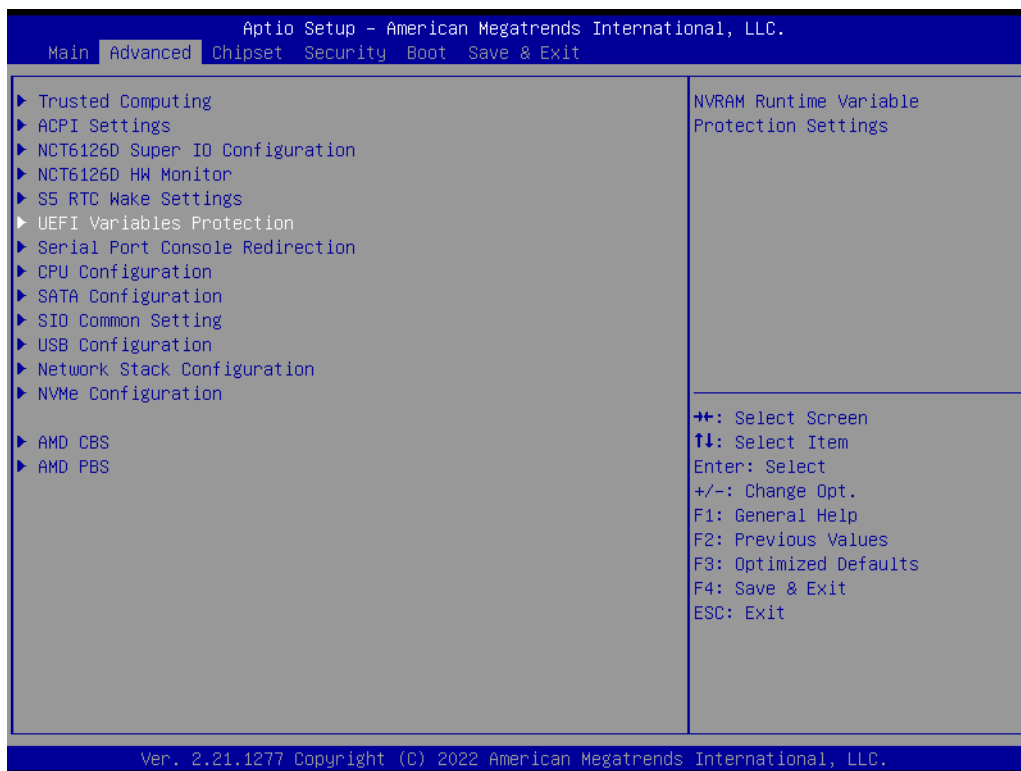

- Password protection of Runtime [Disabled]

3.2.2.10 CPU Configuration

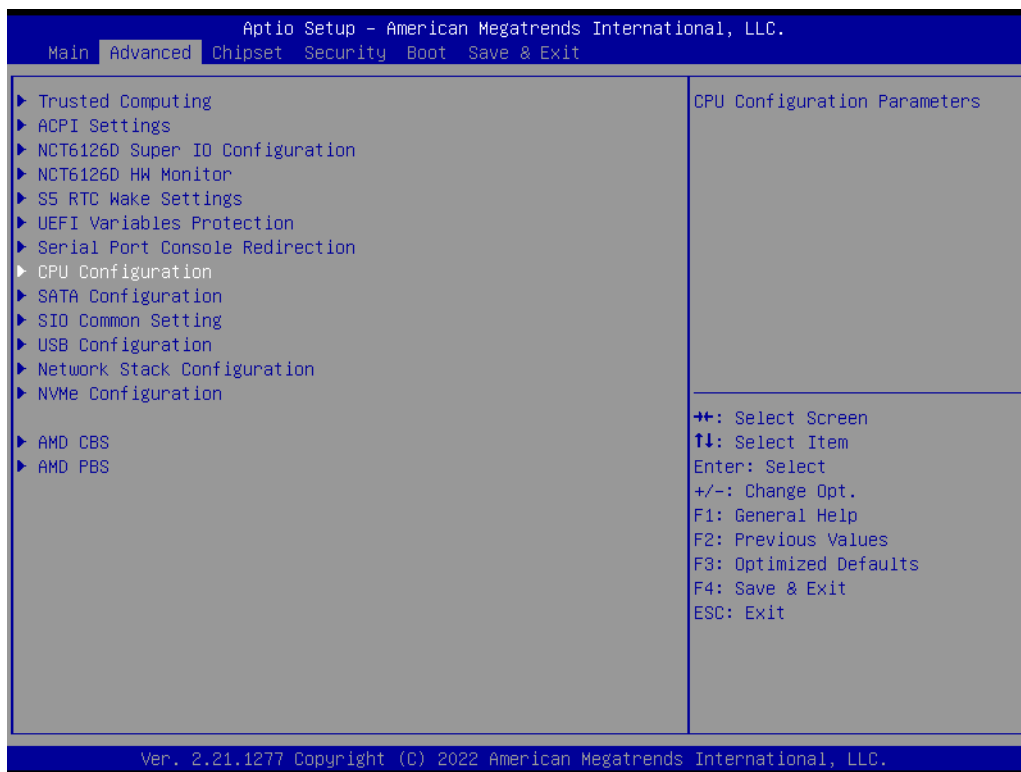

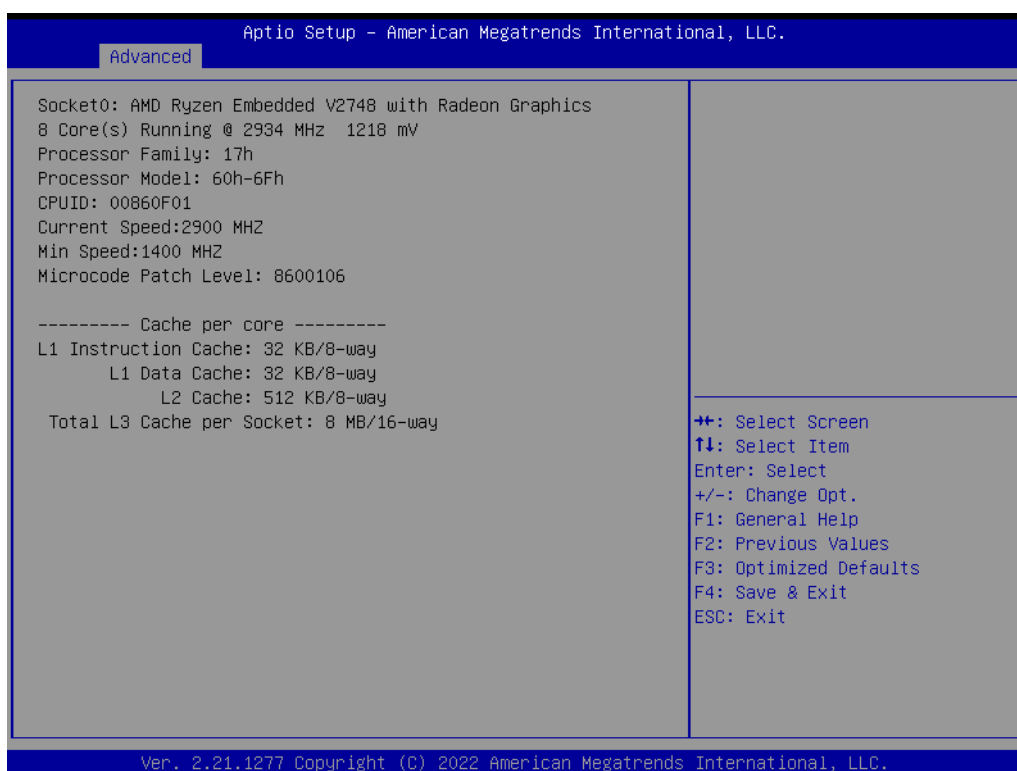

3.2.2.11 SIO Common Setting

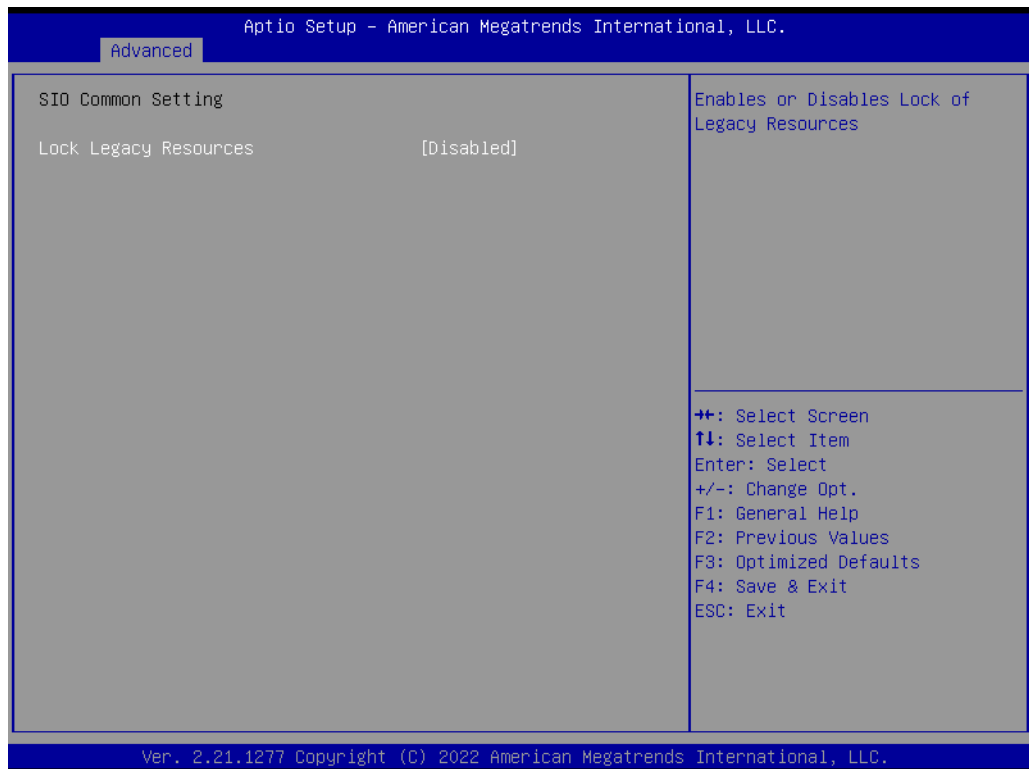
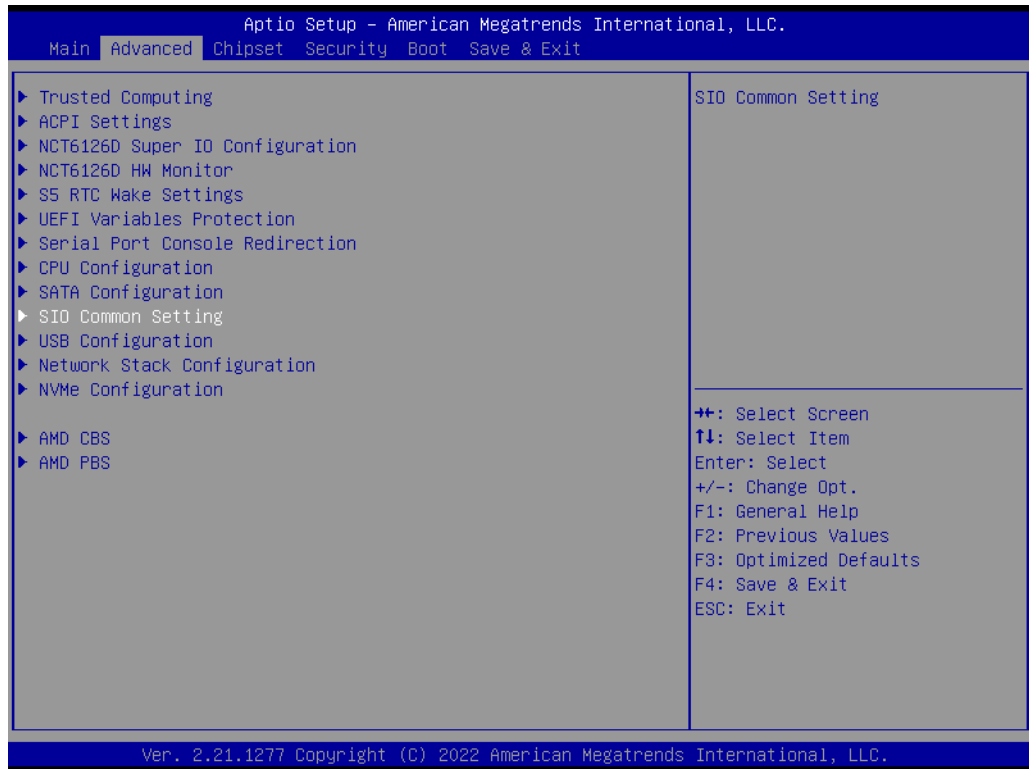

■ Lock Legacy Resources [Disabled]

3.2.2.12 CSM Configuration

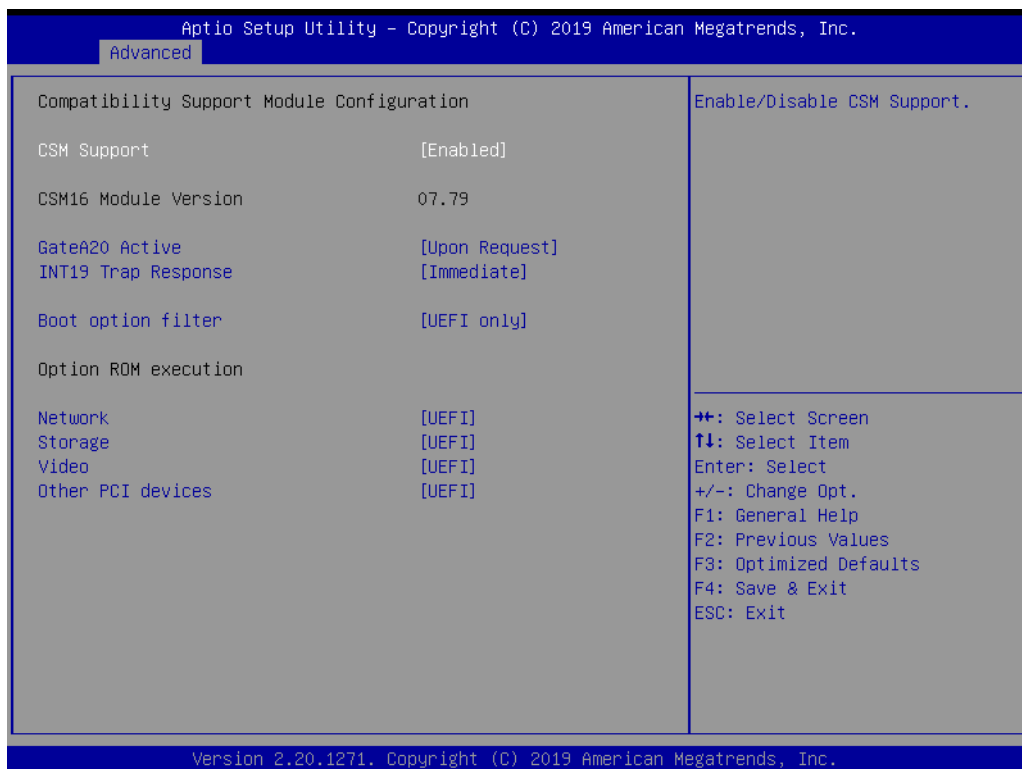

- **Boot Option Filter [UEFI only]**
- **Network [UEFI]**
- **Storage [UEFI]**
- **Video [UEFI]**
- **Other PCI Device [UEFI]**

Note! *If your HDD or other boot device is installed in Legacy mode, it may cause blue screen situation. There are 2 ways to solve this.*



1. *Re-install the OS in UEFI mode.*
2. *Change all of the above settings to Legacy mode.*
3. *Boot option filter -> Legacy only.*
4. *Network -> Legacy.*
5. *Storage -> Legacy.*
6. *Video -> Legacy.*
7. *Other PCI devices -> Legacy.*

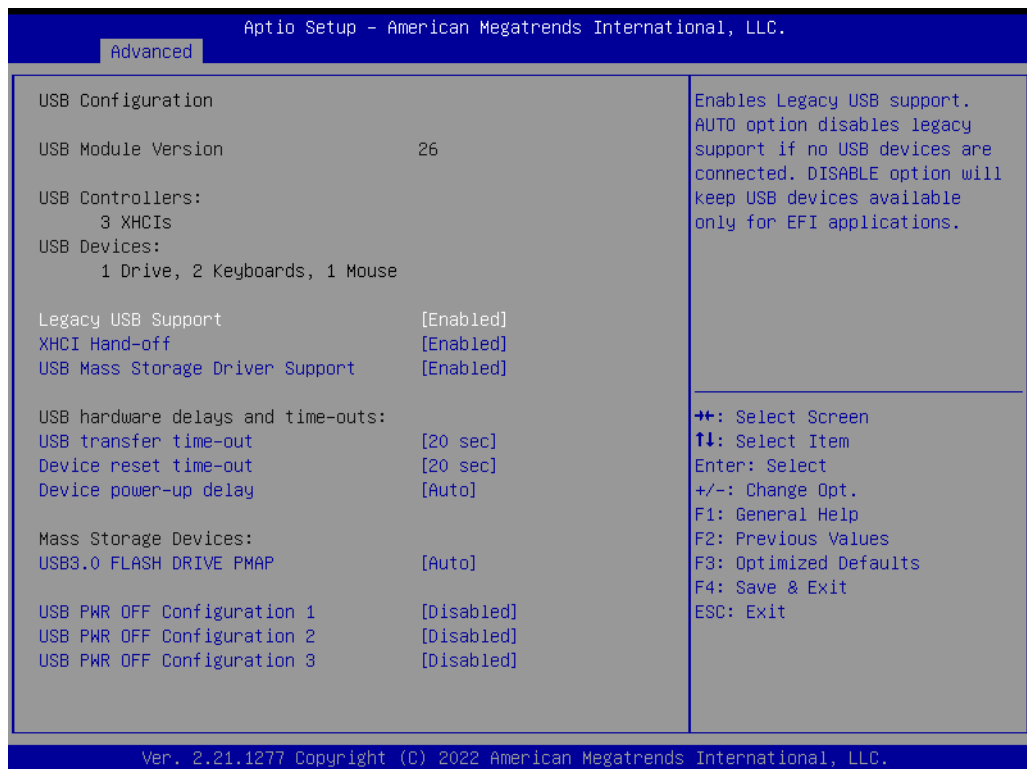
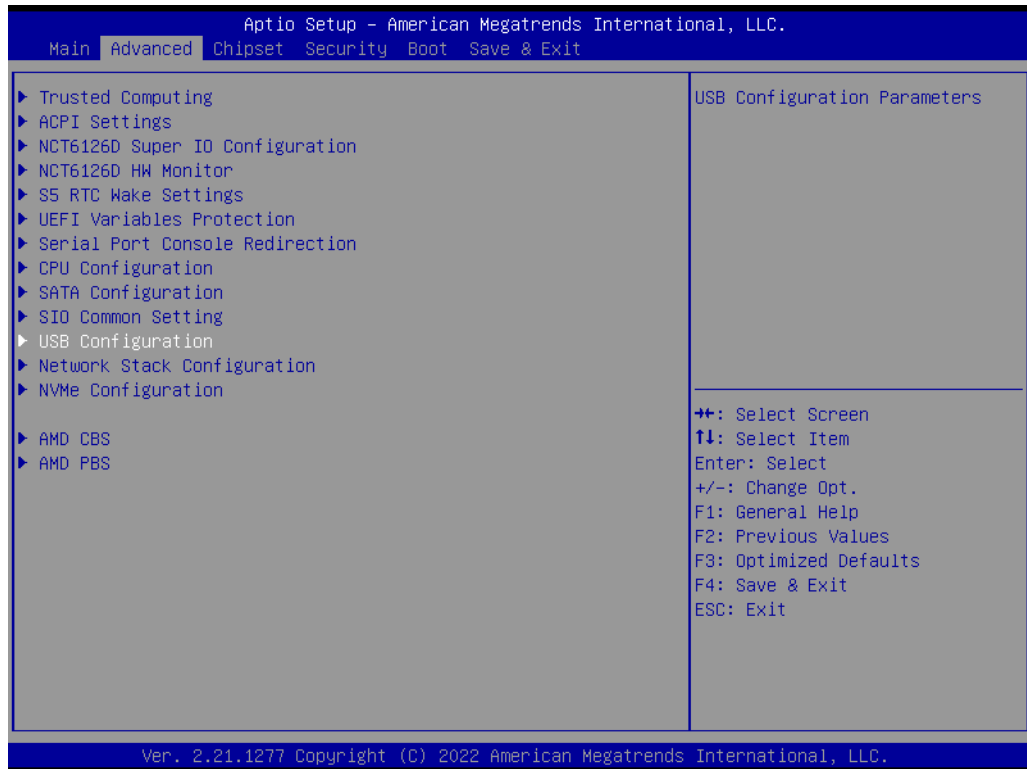

- **Legacy USB Support [Enabled]**
This item allows users to enable/disable support for legacy USB. The “Auto” option disables legacy support if no USB devices are connected.
- **XHCI Hand-Off [Enabled]**
- **USB Mass Storage Driver Support [Enabled]**

- **USB Hardware Delays and Timeouts**
This item allows users to configure the USB device transfer and reset timeout and delay settings.
- **Mass Storage Devices [Auto]**
This item allows users to view USB mass storage device information.

3.3 Chipset Configuration Settings

Select the Chipset tab from the BIOS setup menu to enter the Chipset Setup screen. Users can select any item in the left frame of the screen to access the sub-menu for that item. Users can display a Chipset setup option by highlighting it using the <Arrow> keys. All Chipset Setup options are described in this section. The Chipset Setup screens are shown below. The sub-menus are described in the following sections.

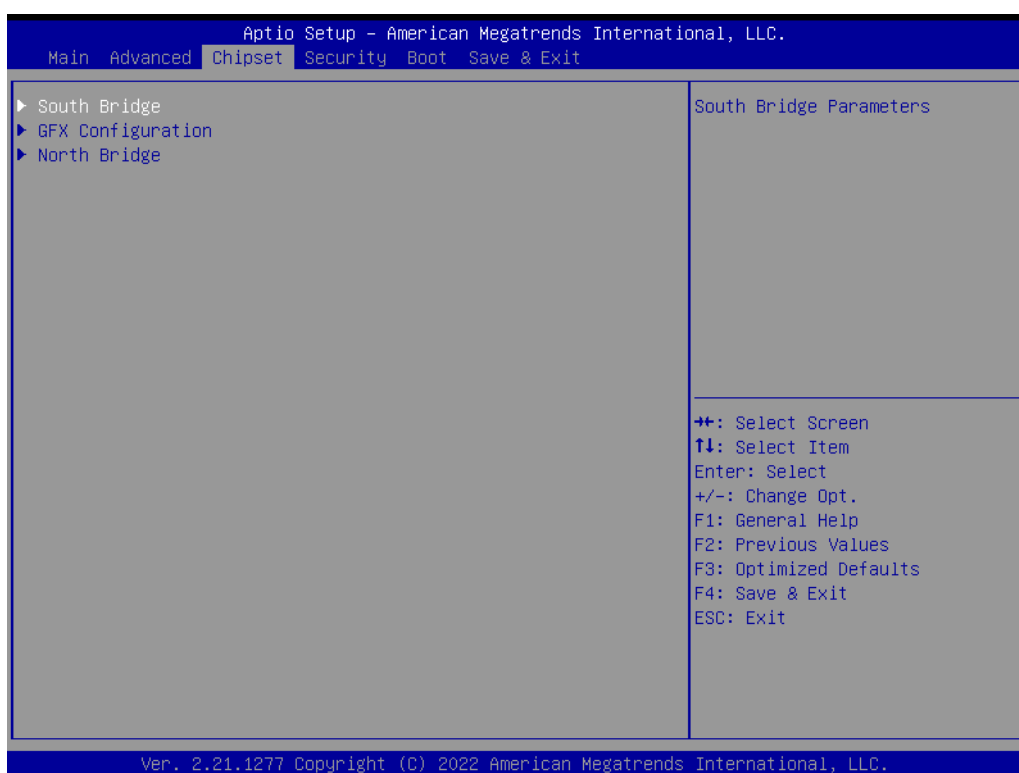

- **South Bridge Configuration**
This item allows users to configure the south bridge settings.
- **GFX Configuration**
This item allows users to view details of the display items.
- **North Bridge Configuration**
This item allows users to configure the north bridge settings.
- **Platform Misc Configuration**
This item allows users to view the platform configuration information.

3.3.1 South Bridge Configuration

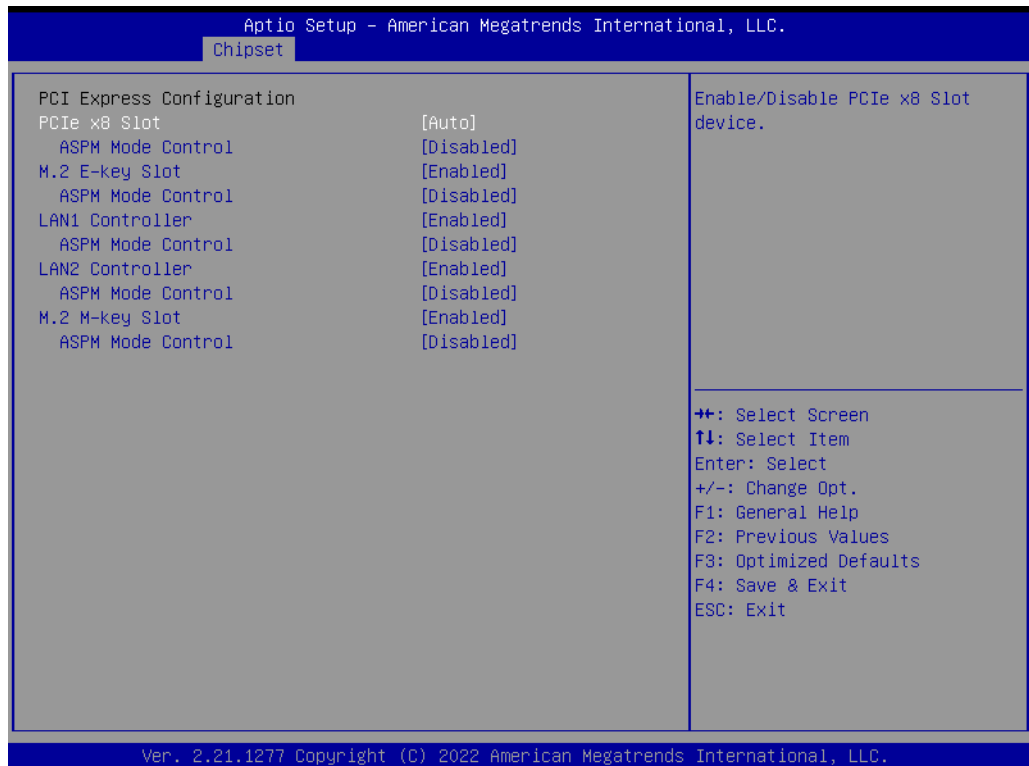
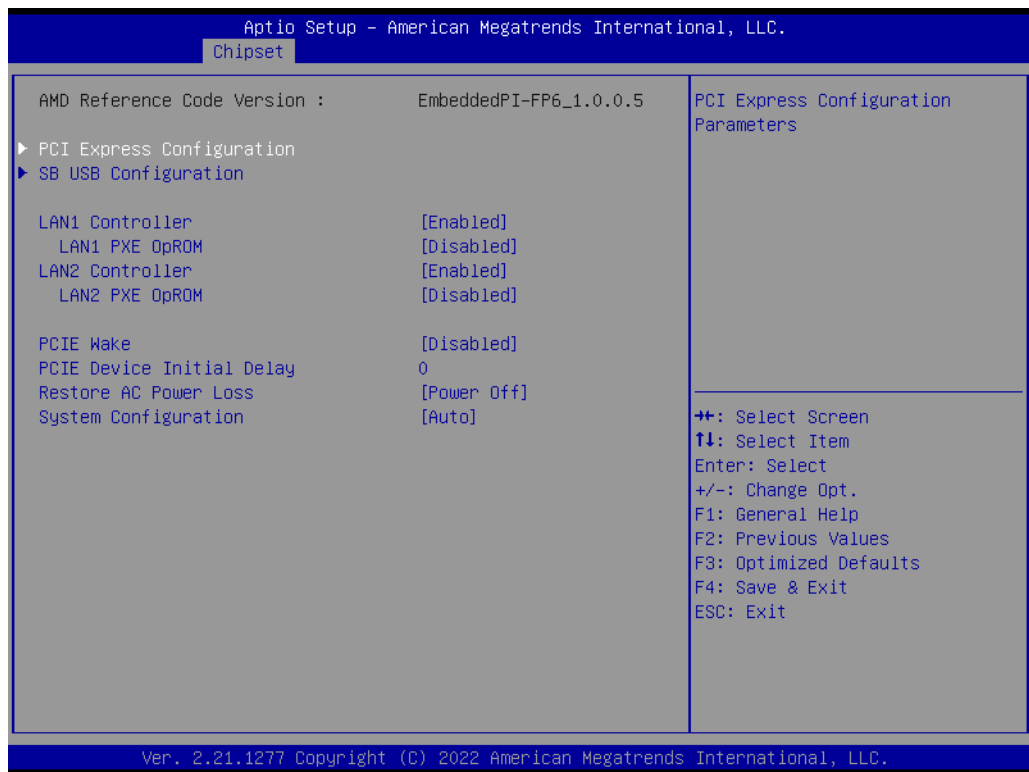

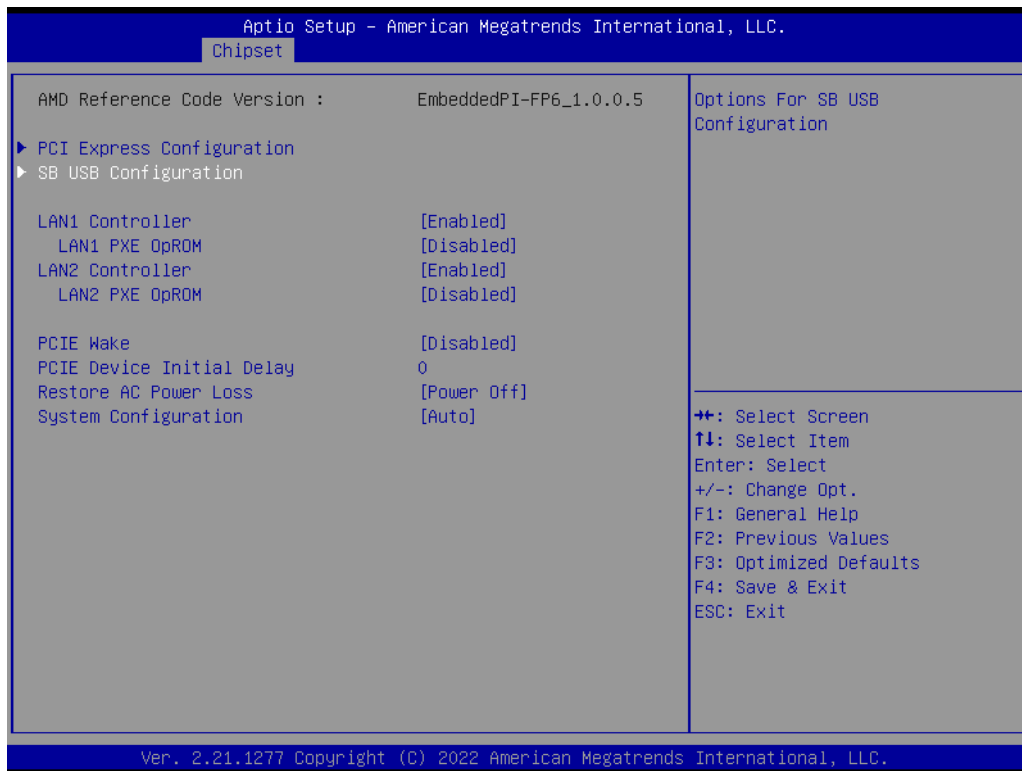

- **SB USB Configuration**
This item allows users to configure the USB settings.
- **SB SATA Configuration**
This item allows users to configure the SATA settings.
- **SB MSIC Configuration**
This item allows users to configure miscellaneous settings.

3.3.2 GFX Configuration

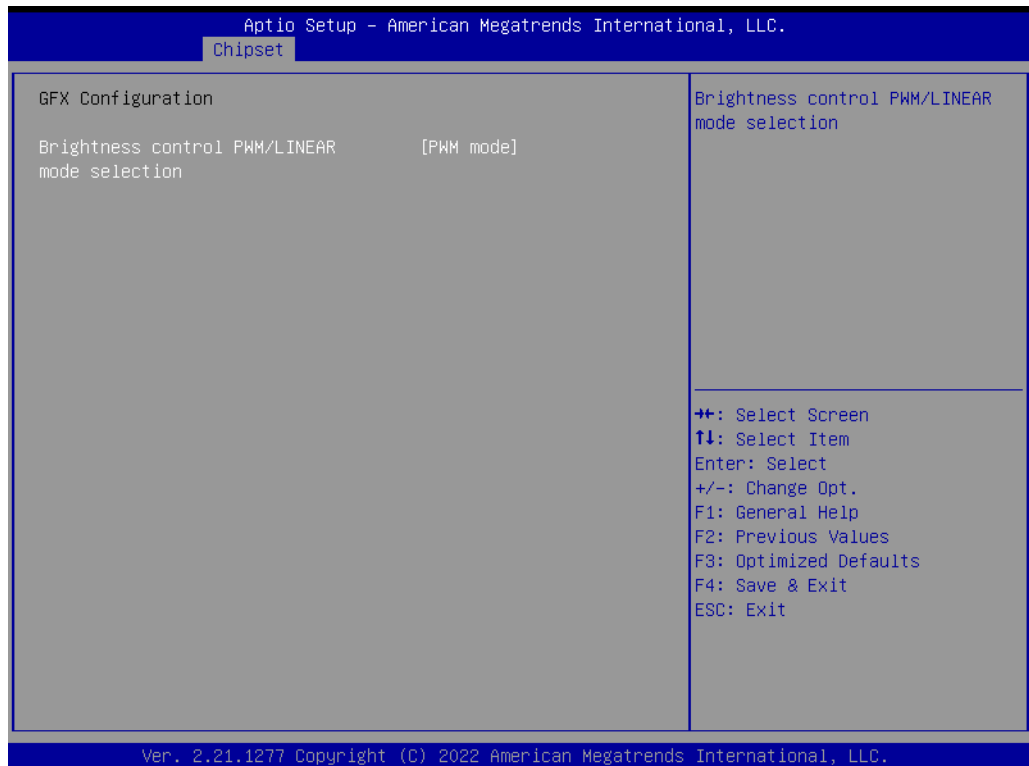

- **Brightness control: PWM mode}**

3.3.3 North Bridge Configuration



3.3.4 Platform Misc Configuration

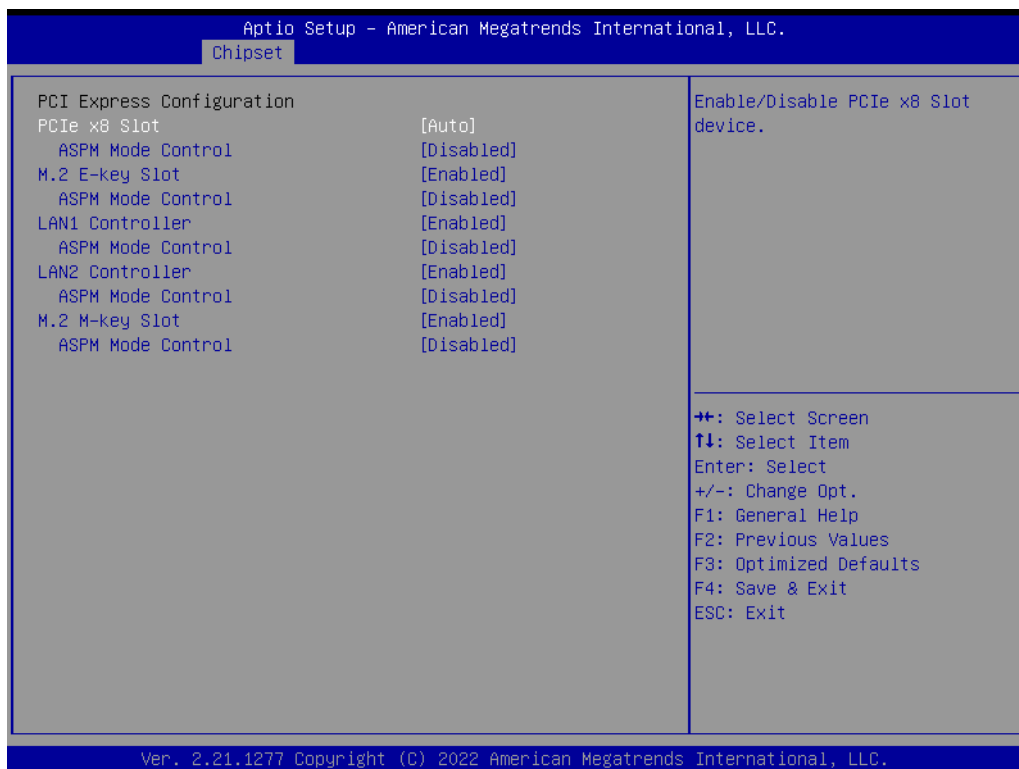

- **PCIe x8 Slot [Auto]**
- **LAN1 Controller [Enabled]**
- **LAN2 Controller [Enabled]**
- **M.2 M-Key Slot [Enabled]**

3.4 Security Settings

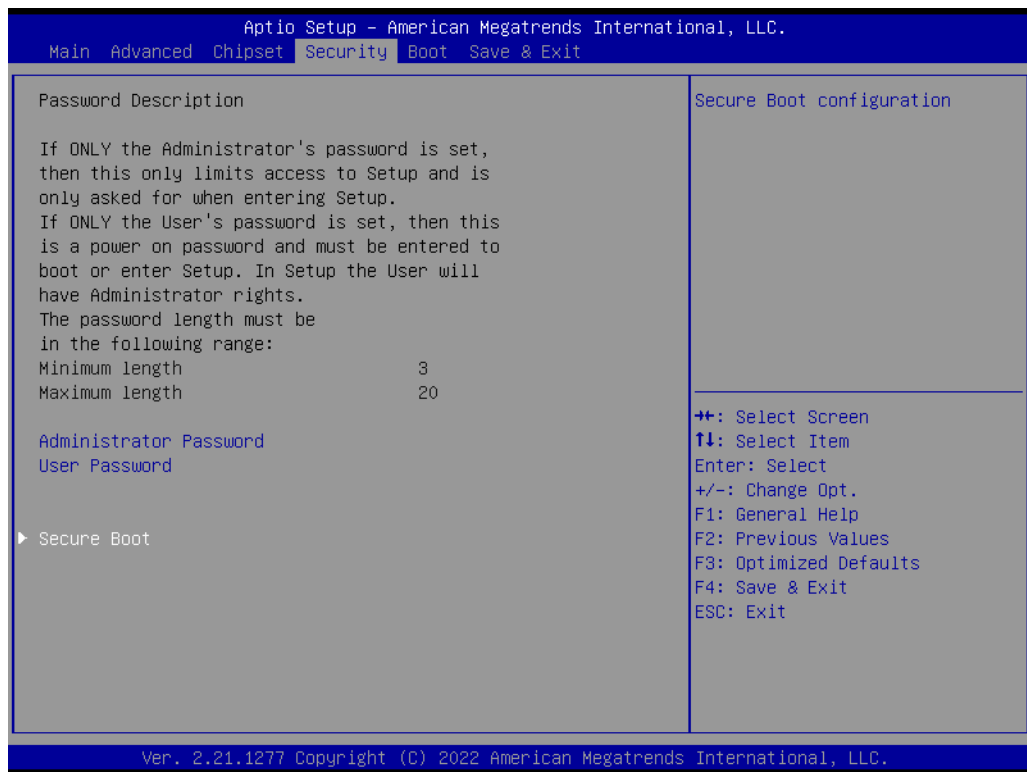

- **Administrator Password**
This item allows users to set the administrator password. Select this option and press <ENTER> to access the sub-menu. Then input the desired password.
- **User Password**
This item allows users to set the user password. Select this option and press <ENTER> to access the sub-menu. Then input the desired password.

3.5 Boot Setting

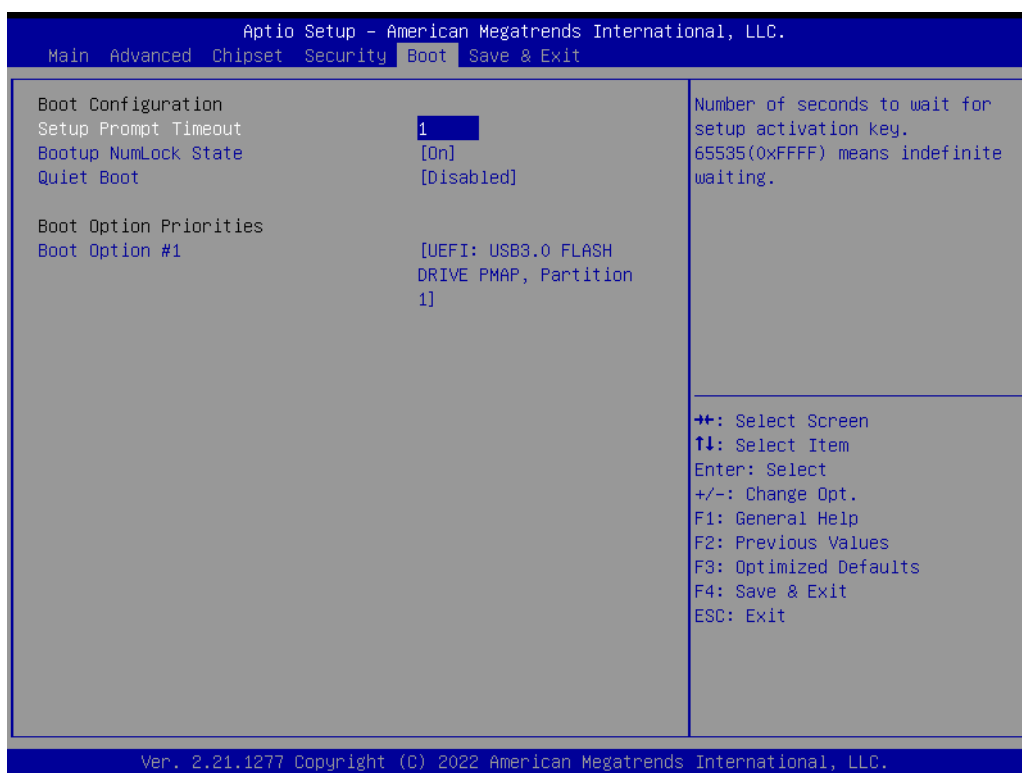

- **Setup Prompt Timeout**
This item allows users to set the setup prompt timeout value. Use the <+> and <-> keys to adjust the number of seconds to wait for setup activation key.
- **Bootup NumLock State [On]**
This item allows users to enable/disable the NumLock state on bootup.
- **Quiet Boot [Disabled]**
This item allows users to enable/disable quiet bootup. If this option is disabled, the BIOS will display normal POST messages. If enabled, an OEM logo is displayed instead of POST messages.
- **Boot Option #1**
This item allows users to set the device bootup priority.

3.6 Save & Exit Configuration

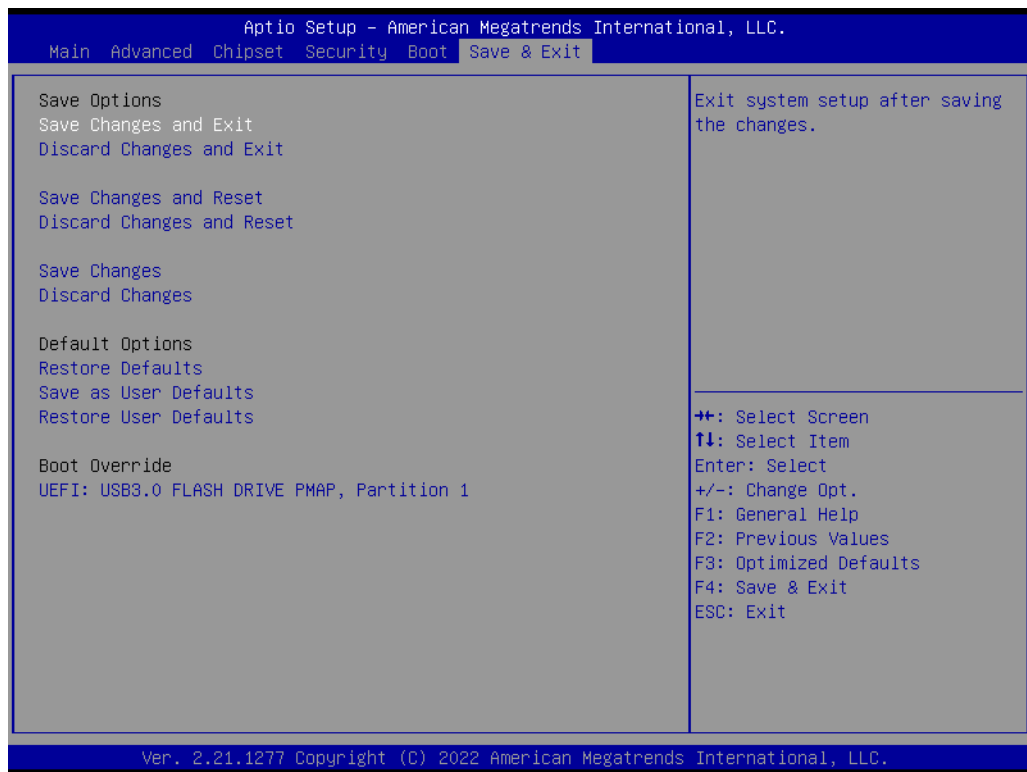

- **Save Changes and Exit**

This item allows users to save changes and exit the BIOS. After completing the system configuration, select this option to save changes and exit the BIOS setup menu.

 1. Select Exit Save Changes from the Exit menu and press <Enter>. The following message will appear: Save configuration changes and exit now? [OK] [Cancel]
 2. Select ok or cancel.
- **Discard Changes and Exit**

This item allows users to exit the BIOS without making changes to the system configuration.

 1. Select Exit Discard Changes from the Exit menu and press <Enter>. The following message will appear: Discard changes and exit setup now? [OK] [Cancel]
 2. Select ok or cancel.
- **Save Changes and Reset**

This item allows users to save changes and reset the system. After completing the system configuration, select this option to save changes, exit the BIOS setup menu, and reboot the computer for all system configuration settings to take effect.

 1. Select Exit Save Changes from the Exit menu and press <Enter>. The following message appears: Save configuration changes and exit now? [OK] [Cancel]
 2. Select ok or cancel.
- **Discard Changes and Reset**

This item allows users to discard changes and reset the system. Select this option to quit the BIOS without making changes to the system configuration.

 1. Select Reset Discard Changes from the Exit menu and press <Enter>. The following message appears: Discard changes and exit setup now? [OK] [Cancel]
 2. Select ok or cancel.

- **Restore Default**
This item allows users to restore the system configuration to the default settings. Select Restore Defaults from the Exit menu and press <Enter>. When this option is selected, the BIOS automatically configures all the setup items to the optimal setting. Defaults are designed for maximum system performance, but may not be ideal for all applications. Do not use default settings if the computer is experiencing configuration problems.
- **Save as User Default**
This item allows users to save all current settings as the user default.
- **Restore User Default**
This item allows users to restore all settings to the user default values.

Chapter 4

Software and Services

4.1 Introduction

The mission of Advantech Embedded Software Services is to “enhance the user experience with Advantech platforms and Microsoft® Windows® embedded technology”. Windows® embedded software products are enabled on Advantech platforms to support the embedded computing community. This frees customers from the hassle of dealing with multiple vendors (hardware suppliers, system integrators, embedded OS distributors).

4.2 Value-Added Software Services

AIMB-229 is equipped with software APIs that define the ways by which application programs may request services from libraries and/or operating systems. Advantech provides the required drivers as well as a comprehensive set of user-friendly, intelligent, and integrated interfaces, which speed development, enhance security, and offer add-on value for Advantech platforms. These software APIs make Advantech embedded platforms easier and simpler to adopt and deploy for diverse applications.

4.2.1 Software API

4.2.1.1 Control

GPIO



General Purpose Input/Output is a flexible parallel interface that allows a variety of custom connections. Allows users to monitor the level of signal input or set the output status to switch on/off the device.

Advantech’s API also offers programmable GPIO, which allows developers to dynamically set the GPIO input or output status.

SMBus



SMBus is the System Management Bus defined by Intel® Corporation in 1995. It is used in personal computers and servers for low-speed system management communications. The SMBus API allows developers to interface an embedded system environment and transfer serial messages using SMBus protocols, enabling simultaneous control of multiple devices.

4.2.1.2 Display

Brightness Control



The Brightness Control API allows developers to access embedded devices and easily control brightness.

Backlight



The Backlight API allows developers to control the screen backlight (on/off) in embedded devices.

4.2.1.3 Monitor

Watchdog



A watchdog timer (WDT) is a device that performs a specific operation after a certain period of time if something goes wrong and the system does not recover on its own. A WDT can be programmed to perform a warm boot (system restart) after a certain number of seconds.

Hardware Monitor



The Hardware Monitor (HWM) API is a system health supervision API that monitors certain condition indexes, such as fan speed, temperature, and voltage.

4.2.1.4 Power Saving

CPU Speed



Uses Intel® SpeedStep technology to reduce power consumption. The system will automatically adjust the CPU speed according to the system load.

Hardware Monitor



Refers to a series of methods for reducing power consumption by lowering the clock frequency. This API allows the user to adjust the clock from 87.5% to 12.5%.

4.2.2 Software Utility

BIOS Flash



The BIOS Flash utility allows customers to update the flash ROM BIOS version, or back up the current BIOS settings by copying the data from the flash chip to a file. The BIOS flash utility also provides a command line and API for rapid implementation in customized applications.

Embedded Security ID



Embedded applications contain valuable intellectual property, design knowledge, and innovation. But this information can be easily copied. The Embedded Security ID utility provides reliable security functions for securing application data within the embedded BIOS.

Monitoring



The Monitoring utility allows customers to monitor the system status and parameters, such as voltage, CPU temperature, and fan speed. If the critical errors occur and are not resolved quickly, permanent damage may result.

Flash Lock



Flash Lock is a mechanism to bind the board and CF card (SQFlash) together. User can lock/unlock the SQFlash card via the Flash Lock function in the BIOS setup menu after bootup. A locked SQFlash cannot be read by any card reader or boot from other platforms without a BIOS with the "Unlock Flash" option.

eSOS



The eSOS is a small OS stored in the BIOS ROM. In the event of a main OS crash, the eSOS will boot up. It will diagnose the hardware and send an e-mail to the designated administrator. The eSOS also supports remote connectivity via a Telnet or FTP server. However, this function must be configured in the BIOS.

Chapter 5

Chipset Software
Installation Utility

5.1 Before Beginning

To ensure problem-free installation of the enhanced display drivers and utility software, read the instructions in this chapter carefully. The drivers for AIMB-229 can be downloaded from the Advantech website. Updates are provided via Microsoft service packs.

5.2 Introduction

The AMD Chipset Software Installation (CSI) utility installs the Windows INF files that outline to the operating system how the chipset components will be configured. This is needed for the proper functioning of the following features:

- Serial ATA interface support
- USB 2.0/3.1 support
- Identification of AMD chipset components in the Device Manager

Note! This utility supports the following versions of Windows, and must be installed before installing all other drivers:



- Windows 10

5.3 Windows 10 Driver Setup

Visit the Advantech website and search AIMB-229. The Chipset driver is provided for download.

Win10 driver for AIMB-229

2022-02-21 | Driver | Document No.1-4784114751

Related Product:

AIMB-229

Solution:

Win10 (64bit) driver for AIMB-229

Win10 (64bit) driver for AIMB-229

AIMB-229_chipset_Win10(64bit)

2022-02-21

Download

AIMB229_Graphic_Win10(64bit)

2022-02-21

Download

AIMB-229_LAN_Win10(64bit)

2022-02-21

Download

AIMB-229_Audio_Win10(64bit)

Chapter 6

LAN Configuration

6.1 Introduction

AIMB-229 features dual Gigabit Ethernet LANs via dedicated PCI Express x1 lanes (Realtek RTL8111H for LAN1&2) that offer bandwidth of up to 500 MB/sec, eliminating network bottlenecks and incorporating Gigabit Ethernet at 1000 Mbps.

6.2 Features

- Integrated 10/100/1000 Mbps transceiver
- 10/100/1000 Mbps triple-speed MAC
- On-chip voltage regulation
- XTAL-Less Wake-on-LAN (WOL) support
- PCIExpress x8 host interface

6.3 Installation

The AIMB-229's Realtek RTL8111H (LAN1&LAN2) Gigabit integrated controllers support all major network operating systems. However, the installation procedure varies from system to system. Please follow the instructions for the appropriate operating system.

6.4 Windows 10 Driver Setup

Visit the Advantech website to obtain the required drivers. Select the LAN folder then navigate to the directory for your OS.

Win10 driver for AIMB-229

2022-02-21 | Driver | Document No.1-4784114751

Related Product:

AIMB-229

Solution:

Win10 (64bit) driver for AIMB-229

Win10 (64bit) driver for AIMB-229

AIMB-229_chipset_Win10(64bit)

2022-02-21

Download

AIMB229_Graphic_Win10(64bit)

2022-02-21

Download

AIMB-229_LAN_Win10(64bit)

2022-02-21

Download

AIMB-229_Audio_Win10(64bit)

Appendix **A**

I/O Pin Assignments

A.1 DC-IN Adaptor Connector (DCIN1)

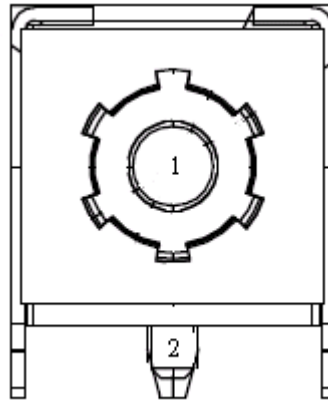

Pin	Signal	Pin	Signal
1	VCC	2	VCC

A.2 HDMI Port Connector (HDMI12)

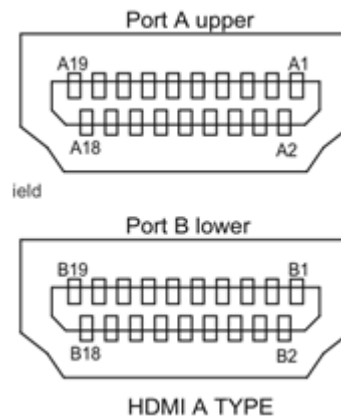

Pin	Signal	Pin	Signal
A1	Port A_TMDS Data2+	A2	Port A_TMDS Data2 Shield
A3	Port A_TMDS Data2-	A4	Port A_TMDS Data1+
A5	Port A_TMDS Data1 Shield	A6	Port A_TMDS Data1-
A7	Port A_TMDS Data0+	A8	Port A_TMDS Data0 Shield
A9	Port A_TMDS Data0-	A10	Port A_TMDS Clock+
A11	Port A_TMDS TMDS Clock Shield	A12	Port A_TMDS Clock-
A13	Port A_CEC	A14	Port A_Reserved
A15	Port A_SCL	A16	Port A_SDA
A17	Port A_DDC/CEC Ground	A18	Port A_+5V Power
A19	Port A_Hot Plug Detect		
B1	Port B_TMDS Data2+	B2	Port B_TMDS Data2 Shield
B3	Port B_TMDS Data2-	B4	Port B_TMDS Data1+
B5	Port B_TMDS Data1 Shield	B6	Port B_TMDS Data1-
B7	Port B_TMDS Data0+	B8	Port B_TMDS Data0 Shield

B9	Port B_TMD5 Data0-	B10	Port B_TMD5 Clock+
B11	Port B_TMD5 TMD5 Clock Shield	B12	Port B_TMD5 Clock-
B13	Port B_CEC	B14	Port B_Reserved
B15	Port B_SCL	B16	Port B_SDA
B17	Port B_DDC/CEC Ground	B18	Port B_+5V Power
B19	Port B_Hot Plug Detect		

A.3 USB31X2_DP2

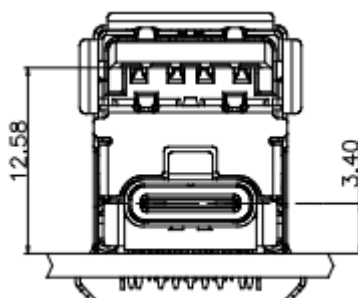

Pin	Signal	Pin	Signal
A1	GND	B1	GND
A2	SSTXP1_1	B2	SSTXP2_2
A3	SSTXN1_1	B3	SSTXN2_2
A4	VBUS	B4	VBUS
A5	CC1	B5	CC2
A6	DP1	B6	DP2
A7	DN1	B7	DN2
A8	SBU1	B8	SBU2
A9	VBUS	B9	VBUS
A10	SSRXN2_1	B10	SSRXN1_2
A11	SSRXP2_1	B11	SSRXP1_2
A12	GND	B12	GND

USB2

Pin	Signal	Pin	Signal
1	VBUS	5	StdA_SSRX-
2	D-	6	StdA_SSRX+
3	D+	7	GND_DRAIN
4	GND	8	StdA_SSTX-
		9	StdA_SSTX+

A.4 USB31X2_DP3

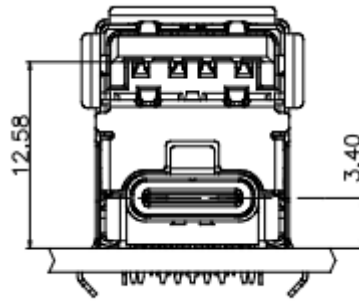

Pin	Signal	Pin	Signal
A1	GND	B1	GND
A2	SSTXP1_1	B2	SSTXP2_2
A3	SSTXN1_1	B3	SSTXN2_2
A4	VBUS	B4	VBUS
A5	CC1	B5	CC2
A6	DP1	B6	DP2
A7	DN1	B7	DN2
A8	SBU1	B8	SBU2
A9	VBUS	B9	VBUS
A10	SSRXN2_1	B10	SSRXN1_2
A11	SSRXP2_1	B11	SSRXP1_2
A12	GND	B12	GND

USB2

Pin	Signal	Pin	Signal
1	VBUS	5	StdA_SSRX-
2	D-	6	StdA_SSRX+
3	D+	7	GND_DRAIN
4	GND	8	StdA_SSTX-
		9	StdA_SSTX+

A.5 USB34

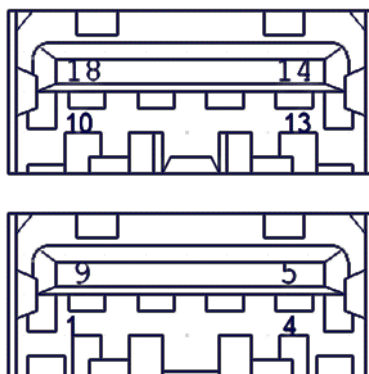

Pin	Signal	Pin	Signal
1	VBUS_1	5	StdA_SSRX-_1
2	D-_1	6	StdA_SSRX+_1
3	D+_1	7	GND_DRAIN_1
4	GND_1	8	StdA_SSTX-_1
		9	StdA_SSTX+_1

Pin	Signal	Pin	Signal
1	VBUS_2	5	StdA_SSRX-_2
2	D-_2	6	StdA_SSRX+_2
3	D+_2	7	GND_DRAIN_2
4	GND_2	8	StdA_SSTX-_2
		9	StdA_SSTX+_2

A.6 AT/ATX Mode Selection (PSON1)



Pin	Signal
1	VCCAT
2	+3.3V
3	VCCATX

A.7 RJ45(LAN1+LAN2) Connector (LAN12)

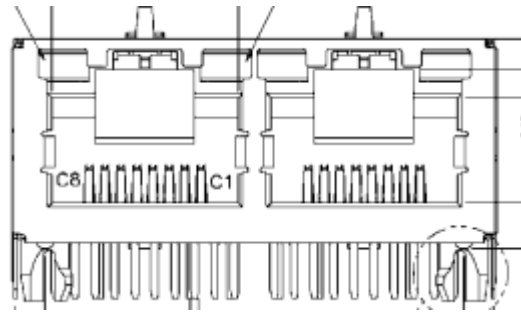

Pin	Signal Pin Definition	Pin	Signal Pin Definition
AR1	LAN1_MDI0+	BR1	LAN2_MDI0+
AR2	LAN1_MDI0-	BR2	LAN2_MDI0-
AR3	LAN1_MDI1+	BR3	LAN2_MDI1+
AR4	LAN1_MDI1-	BR4	LAN2_MDI1-
AR5	LAN1_CONN	BR5	LAN2_CONN
AR6	LAN1_CT	BR6	LAN2_CT
AR7	LAN1_MDI2+	BR7	LAN2_MDI2+
AR8	LAN1_MDI2-	BR8	LAN2_MDI2-
AR9	LAN1_MDI3+	BR9	LAN2_MDI3+
AR10	LAN1_MDI3-	BR10	LAN2_MDI3-
AL1	LAN1_LED1_ACT#_R	BL1	LAN2_LED0_ACT#_R
AL2	+V3.3_DUAL	BL2	+V3.3_DUAL
AL3	LAN1_LED2_1G#_R	BL3	LAN2_LED2_1G#_R
AL4	LAN1_LED0_100M#_R	AL4	LAN2_LED0_100M#_R

A.8 HD Analog Audio Interface Line-Out (AUDIO1)

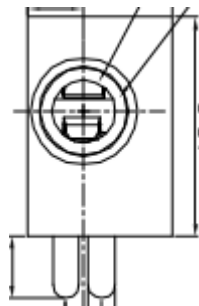

Pin	Signal
1	GND
2	LINE OUT-L
3	LINE OUT-L
4	FRONT-JD
5	GND

A.9 HD Analog Audio Interface MIC-In (AUDIO2)

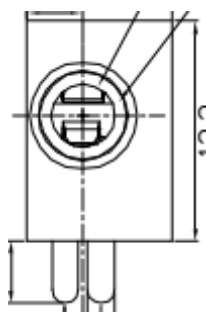

Pin	Signal
1	GND
2	MIC-L
3	MIC-L
4	MIC-JD
5	GND

A.10 Audio Amplifier Output Pin Header (AMP1)

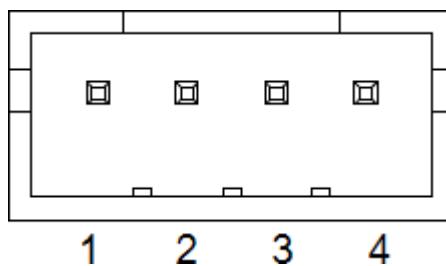

Pin	Signal
1	AMP OUT - R+
2	AMP OUT - R-
3	AMP OUT - L-
4	AMP OUT - L+

A.11 Front Panel Audio Header (FPAUD1)

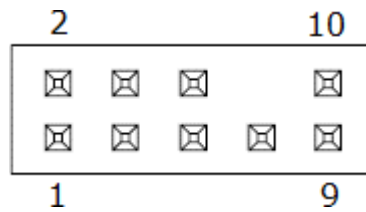

Pin	Signal	Pin	Signal
1	MIC IN - L	2	GND
3	MIC IN - R	4	FPAUD_DETECT#
5	LINE OUT - R	6	SENSE R1
7	SENSE	8	KEY
9	LINE OUT - L	10	SENSE R2

A.12 CMOS Battery Wafer Box (BAT1)

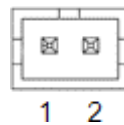

Pin	Signal
1	VCC
2	GND

A.13 Serial ATA Interface Connector #2 (SATA2)

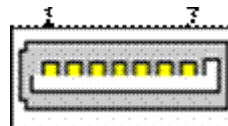

Pin	Signal
1	GND
2	TX+
3	TX-
4	GND
5	RX-
6	RX+
7	GND

A.14 HD Audio Interface (SPDIF1)



Pin	Signal
1	+5V
2	KEY
3	SPDIF OUT
4	GND

A.15 M.2 -Key (NGFF_M1)

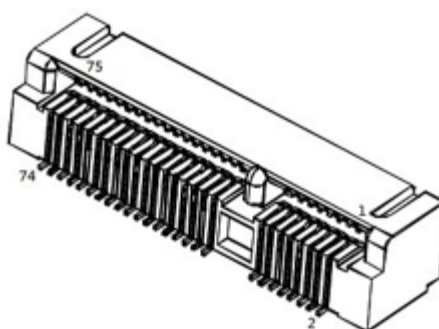

Pin	Signal	Pin	Signal
1	GND_1	2	3p3V_1
3	GND_2	4	3p3V_2
5	PERN3	6	NC_1
7	PERP3	8	NC_2
9	GND_3	10	DAS/D\S\S\I/O/L\E\D\1\I-O/3p3V
11	PETN3	12	3p3V_3
13	PETP3	14	3p3V_4
15	GND_4	16	3p3V_5
17	PERN2	18	3p3V_6
19	PERP2	20	NC_3
21	GND_5	22	NC_4
23	PETN2	24	NC_5
25	PETP2	26	NC_6
27	GND_6	28	NC_7
29	PERN1	30	NC_8
31	PERP1	32	NC_9
33	GND_7	34	NC_10
35	PETN1	36	NC_11
37	PETP1	38	DEVSLP-O
39	GND_8	40	NC_12

41	PERN0/SATA-B+	42	NC_13
43	PERP0/SATA-B-	44	NC_14
45	GND_9	46	NC_15
47	PETN0/SATA-A-	48	NC_16
49	PETP0/SATA-A+	50	P\E\R\I\S\T\I-O-0/3p3V/NC
51	GND_10	52	C\L\I\K\R\E\Q\I-I/O-0/3p3V/NC
53	REFCLKN	54	P\E\W\A\K\E-I/O-0/3p3V/NC
55	REFCLKP	56	NC_17
57	GND_11	58	NC_18
67	NC_19	68	SUSCLK-32KHZ-O-0/3p3V
69	PEDET-NC-PCIE/GND-SATA	70	3p3V_7
71	GND_12	72	3p3V_8
73	GND_13	74	3p3V_9
75	GND_14		

A.16 EDP Differential Signaling (EDP1)

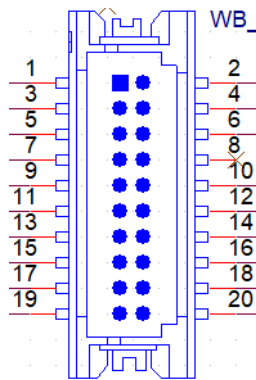

Pin	Signal	Pin	Signal
1	GND	2	GND
3	ED0-	4	ED3-
5	ED0+	6	ED3+
7	GND	8	NC
9	ED1-	10	GND
11	ED1+	12	AUX-
13	GND	14	AUX+
15	ED2-	16	GND
17	ED2+	18	HPD
19	LVDS VCON	20	LVDS VCON

A.17 PCI Express x8 Slot (PCIEX8_1)

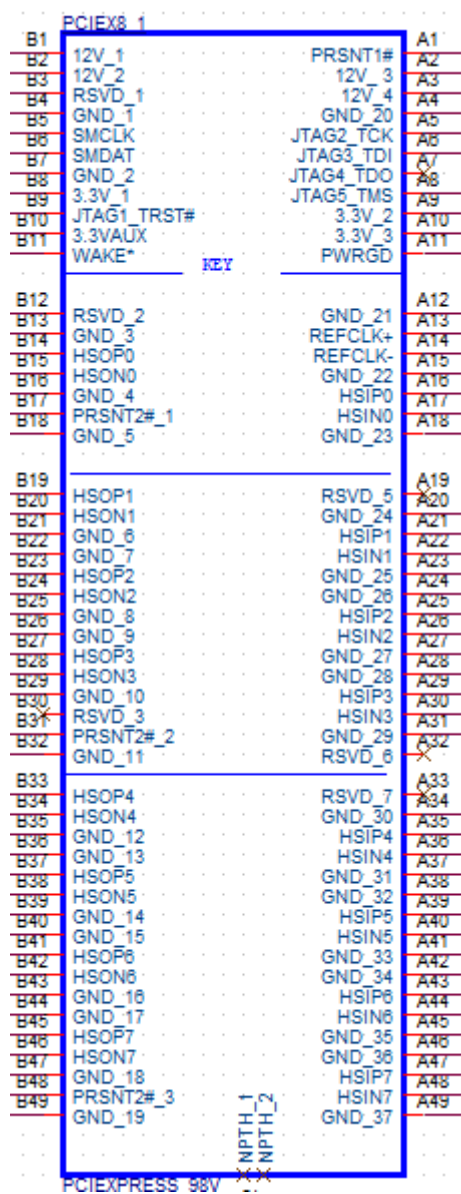

Pin	Signal	Pin	Signal
A1	PRSNT1#	B1	12V_1
A2	12V_3	B2	12V_2
A3	12V_4	B3	RSVD_1
A4	GND_20	B4	GND_1
A5	JTAG2_TCK	B5	SMCLK
A6	JTAG3_TDI	B6	SMDAT
A7	JTAG4_TDO	B7	GND_2
A8	JTAG5_TMS	B8	3.3V_1
A9	3.3V_2	B9	JTAG1_TRST#
A10	3.3V_3	B10	3.3VAUX
A11	PWRGD	B11	WAKE*
A12	GND_21	B12	RSVD_2
A13	REFCLK+	B13	GND_3

A14	REFCLK-	B14	HSOP0
A15	GND_22	B15	HSO00
A16	HSIP0	B16	GND_4
A17	HSIN0	B17	PRSNT2#_1
A18	GND_23	B18	GND_5
A19	RSVD_5	B19	HSOP1
A20	GND_24	B20	HSO01
A21	HSIP1	B21	GND_6
A22	HSIN1	B22	GND_7
A23	GND_25	B23	HSOP2
A24	GND_26	B24	HSO02
A25	HSIP2	B25	GND_8
A26	HSIN2	B26	GND_9
A27	GND_27	B27	HSOP3
A28	GND_28	B28	HSO03
A29	HSIP3	B29	GND_10
A30	HSIN3	B30	RSVD_3
A31	GND_29	B31	PRSNT2#_2
A32	RSVD_6	B32	GND_11
A33	RSVD_7	B33	HSOP4
A34	GND_30	B34	HSO04
A35	HSIP4	B35	GND_12
A36	HSIN4	B36	GND_13
A37	GND_31	B37	HSOP5
A38	GND_32	B38	HSO05
A39	HSIP5	B39	GND_14
A40	HSIN5	B40	GND_15
A41	GND_33	B41	HSOP6
A42	GND_34	B42	HSO06
A43	HSIP6	B43	GND_16
A44	HSIN6	B44	GND_17
A45	GND_35	B45	HSOP7
A46	GND_36	B46	HSO07
A47	HSIP7	B47	GND_18
A48	HSIN7	B48	PRSNT2#_3
A49	GND_37	B49	GND_19

A.18 USB 2.0 Front-Panel Header (USB56)

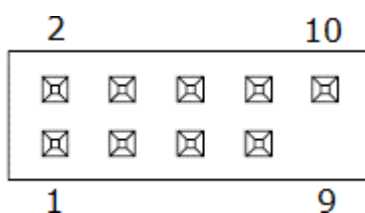

Pin	Signal	Pin	Signal
1	VBUS	2	VBUS
3	D-	4	D-
5	D+	6	D+
7	GND	8	GND
		10	NC

A.19 CPU Fan #1 Connector (CPUFAN1)



Pin	Signal
1	GND
2	CPU fan VCC
3	CPU fan speed
4	CPU fan PWM

A.20 M.2 E-Key Connector (M2E1)

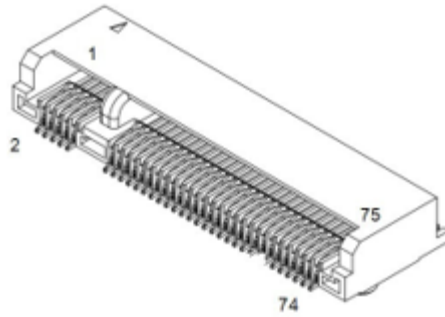

Pin	Signal	Pin	Signal
1	GND	2	+3.3V AUX
3	USB_D+	4	+3.3V AUX
5	USB_D-	6	Wi-Fi_LED#
7	GND	8	I2S SCK
9	NC	10	I2S WS
11	NC	12	I2S SD_IN
13	NC	14	I2S SD_OUT
15	NC	16	BT_LED#
17	NC	18	GND
19	NC	20	UART WAKE#
21	NC	22	UART RXD
23	NC	24	KEY
25	KEY	26	KEY
27	KEY	28	KEY
29	KEY	30	KEY
31	KEY	32	UART TXD
33	GND	34	UART CTS
35	PETp0	36	UART RTS
37	PETn0	38	NC
39	GND	40	NC
41	PERp0	42	NC
43	PERn0	44	NC
45	GND	46	NC
47	REFCLKp0	48	NC
49	REFCLKn0	50	SUSCLK
51	GND	52	PERST0#
53	CLKREQ0#	54	W_DISABLE2#
55	PEWAKE0#	56	W_DISABLE1#
57	GND	58	NC
59	NC	60	NC
61	NC	62	NC
63	GND	64	NC
65	NC	66	NC
67	NC	68	NC

69	GND	70	NC
71	NC	72	+3.3V AUX
73	NC	74	+3.3V AUX
75	GND		

A.21 COM2 Box Header (COM2)

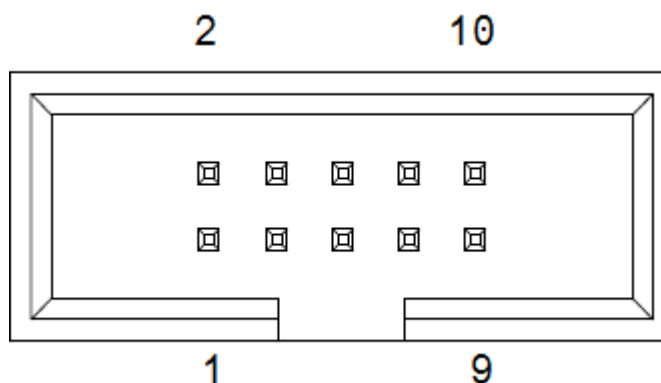

Pin	Signal	Pin	Signal
1	DCD# [2]	2	DSR# [2]
3	RXD [2]	4	RST# [2]
5	TXD [2]	6	CTS# [2]
7	DTR# [2]	8	RI# [2]
9	GND		

A.22 COM1 RI# Selection Pin Header (JSETCOM1_V1)

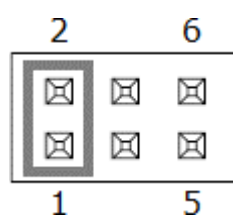

Pin	Signal	Pin	Signal
1	RI# [6]	2	Advantech defined
3	Advantech defined	4	+5V
5	+12V	6	Advantech defined

A.23 Inverter Power Connector (INV1)

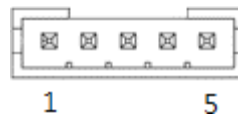

Pin	Signal
1	+12V
2	GND
3	BKL EN
4	BKL CTRL
5	+5V

A.24 16-bit General Purpose I/O Pin Header (GPIO1)

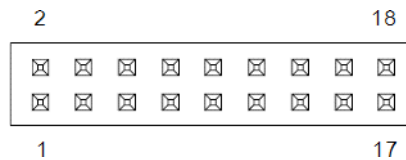

Pin	Signal	Pin	Signal
1	GPIO0	2	GPIO8
3	GPIO1	4	GPIO9
5	GPIO2	6	GPIO10
7	GPIO3	8	GPIO11
9	GPIO4	10	GPIO12
11	GPIO5	12	GPIO13
13	GPIO6	14	GPIO14
15	GPIO7	16	GPIO15
17	+5V AUX	18	GND

A.25 COM4 RI Selection Pin Header (JSETCOM4_V1)

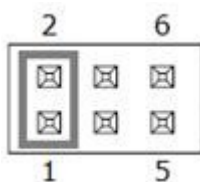

Pin	Signal	Pin	Signal
1	RI# [6]	2	Advantech defined
3	Advantech defined	4	+5V
5	+12V	6	Advantech defined

A.26 CCTALK Voltage Selection Pin Header (JCCT_VCON1)

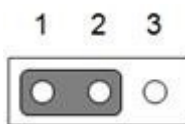

Pin	Signal
1	+12V
2	Advantech defined
3	+5V

A.27 COM3 ~ COM4 Box Header (COM34)

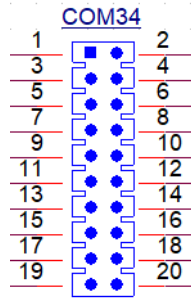

Pin	Signal	Pin	Signal
1	DCD# [3]	2	DSR# [3]
3	RXD [3]	4	RST# [3]
5	TXD [3]	6	CTS# [3]
7	DTR# [3]	8	RI# [3]
9	GND	10	GND
11	DCD# [4]	12	DSR# [4]
13	RXD [4]	14	RST# [4]
15	TXD [4]	16	CTS# [4]
17	DTR# [4]	18	RI# [4]
19	GND	20	GND

A.28 COM5 ~ COM6 Box Header (COM56)

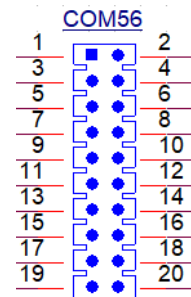

Pin	Signal	Pin	Signal
1	DCD# [3]	2	DSR# [3]
3	RXD [3]	4	RST# [3]
5	TXD [3]	6	CTS# [3]
7	DTR# [3]	8	RI# [3]
9	GND	10	GND
11	DCD# [4]	12	DSR# [4]
13	RXD [4]	14	RST# [4]
15	TXD [4]	16	CTS# [4]
17	DTR# [4]	18	RI# [4]
19	GND	20	GND

A.29 COM1 Box Header (COM1)

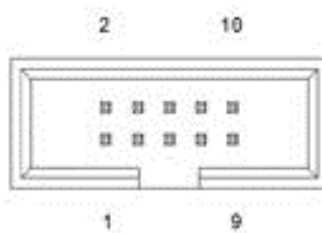

Pin	Signal	Pin	Signal
1	DCD# [1]	2	DSR# [1]
3	RXD [1]	4	RST# [1]
5	TXD [1]	6	CTS# [1]
7	DTR# [1]	8	RI# [1]
9	GND		

A.30 Low-Pin-Count Interface Connector (LPC1)

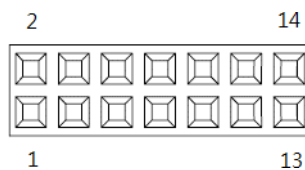

Pin	Signal	Pin	Signal
1	LPC CLK	2	LPC AD1
3	LPC RESET#	4	LPC AD0
5	LPC FRAME#	6	+3.3V
7	LPC AD3	8	GND
9	LPC AD2	10	SMB_CLK
11	LPC SERIRQ	12	SMB_DATA
13	+5V AUX	14	+5V

A.31 Serial ATA Power Connector #1 (SATA_PWR1)

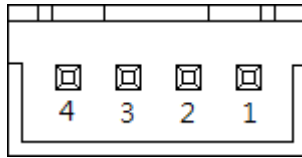

Pin	Signal
1	+5V
2	GND
3	GND
4	+12V

A.32 Serial ATA Power Connector #2 (SATA_PWR2)

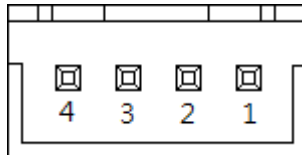

Pin	Signal
1	+5V
2	GND
3	GND
4	+12V

A.33 DDR4 SODIMM Socket CH-A (DIMMA1)

Please see JEDEC STANDARD.

A.34 DDR4 SODIMM Socket CH-B (DIMMB1)

Please see JEDEC STANDARD.

A.35 Power LED & Keyboard Lock Pin Header (JFP2)

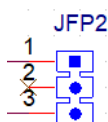

Pin	Signal
1	Power LED
2	NC
3	Power LED

A.36 Watchdog Timer Output and OBS Beep (JWDT1+JOBS1)



Pin	Signal
1	NC
2	WDT
3	RESET#
4	SIO BEEP
5	FRP BEEP

A.37 Case Open Connector (JCASE2)

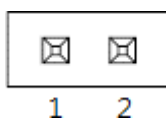

Pin	Signal
1	Case Open
2	GND

A.38 PWRBTN#/RESET#/HDD LED/Serial Bus From HW Monitor IC/Internal Buzzer/External Speaker Header (JFP1)

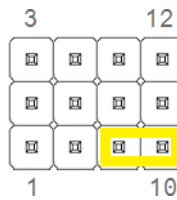

Pin	Signal	Pin	Signal
1	+5V	2	HDD LED+
3	PWRBTN+	4	SPK_P2
5	HDD LED-	6	PWRBTN-
7	SPK_P3	8	SMB_DATA
9	RESET+	10	SPK_P4
11	SMB_CLK	12	RESET-

A.39 System Fan #2 Connector (SYSFAN2)

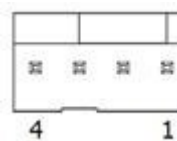

Pin	Signal
1	GND
2	SYSTEM FAN VCC
3	SYSTEM FAN SPEED
4	SYSTEM FAN PWM

A.40 System Fan #1 Connector (SYSFAN1)

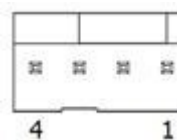

Pin	Signal
1	GND
2	SYSTEM FAN VCC
3	SYSTEM FAN SPEED
4	SYSTEM FAN PWM

A.41 SPI Pin Header (BIOS1_CN1)

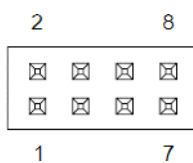

Pin	Signal	Pin	Signal
1	CS#	2	+1.8V
3	MISO	4	NC
5	NC	6	SCLK
7	GND	8	MOSI

A.42 SPI BIOS Flash Socket (BIOS1)

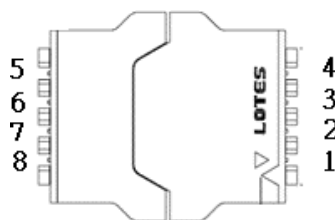

Pin	Signal	Pin	Signal
1	CS#	5	MOSI
2	MISO	6	SCLK
3	WP#	7	HOLD#
4	GND	8	+3.3V

A.43 VDD Select for LVDS1 Panel (JEDP1)

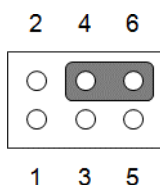

Pin	Signal	Pin	Signal
1	NC	2	+5V
3	+12V	4	VDD
5	NC	6	+3.3V

A.44 COMS Mode Selection (JCMOS1)



Pin	Signal
1	VBAT
2	RTC
3	GND



Jumper Setting List

	Description	Part Reference
1	VDD select for LVDS1 panel	JLVDS1
2	CMOS clear	JCOMS1
3	COM1_RI# pin selection	JSETCOM1_V1
4	COM4_RI# pin selection	JSETCOM4_V1
5	CCTALK selection pin header	JCCT_VCON1
6	AT/ATX mode selection	PSON1
7	PWRBTN#/RESET#/HDD LED/serial bus/ internal buzzer/ JFP1 external speaker header	JFP1
8	Watchdog timer output and OBS beep	JWDT1+JOBS1



A.45 VDD Select for LVDS1 Panel (JEDP1)

Function	Jumper Setting
Jumper position for +3.3V (default)	<p>2 4 6</p> <p>1 3 5</p>
Jumper position for +5V	<p>2 4 6</p> <p>1 3 5</p>
Jumper position for +12V	<p>2 4 6</p> <p>1 3 5</p>



A.46 CMOS Clear (JCMOS1)

Function	Jumper Setting
Normal (default)	<p>1 2 3</p> 
Clear CMOS data	<p>1 2 3</p> 



A.47 COM1_RI# Pin Selection (JSETCOM1_V1)

Function	Jumper Setting
Jumper position for RI# (default)	<p>2 4 6</p>  <p>1 3 5</p>
Jumper position for +5V	<p>2 4 6</p>  <p>1 3 5</p>
Jumper position for +12V	<p>2 4 6</p>  <p>1 3 5</p>

A.48 COM4_RI# Pin Selection (JSETCOM4_V1)

Function	Jumper Setting
Jumper position for RI# (default)	<p>2 4 6</p>  <p>1 3 5</p>
Jumper position for +5V	<p>2 4 6</p>  <p>1 3 5</p>
Jumper position for +12V	<p>2 4 6</p>  <p>1 3 5</p>

A.49 CCTALK Selection Pin Header (JCCT_VCON1)

Function	Jumper Setting
CCTALK 12V (default)	<p>1 2 3</p> 
CCTALK 5V	<p>1 2 3</p> 

A.50 AT/ATX Mode Selection (PSON1)

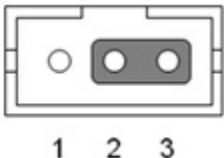
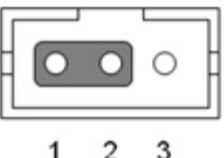
Function	Jumper Setting
ATX mode (default)	
AT mode	

A.51 PWRBTN#/RESET#/HDD LED/Serial Bus/Internal Buzzer/External Speaker Header (JFP1)

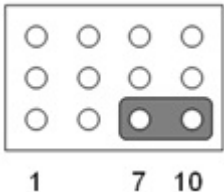
Function	Jumper Setting
Internal buzzer (default)	

A.52 Watchdog Timer Output and OBS Beep (JWDT1+JOBS1)

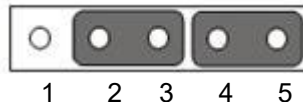
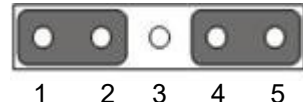
Function	Jumper Setting
Watchdog timer output (2-3) (default) OBS BEEP(4-5) (default)	
Watchdog timer disable (1-2) OBS beep (4-5) (default)	

ADVANTECH

Enabling an Intelligent Planet

www.advantech.com

Please verify specifications before quoting. This guide is intended for reference purposes only.

All product specifications are subject to change without notice.

No part of this publication may be reproduced in any form or by any means, such as electronically, by photocopying, recording, or otherwise, without prior written permission from the publisher.

All brand and product names are trademarks or registered trademarks of their respective companies.

© Advantech Co., Ltd. 2022